

Wireless LED Steady/ Flashing Tower Light

QTG-WIZ

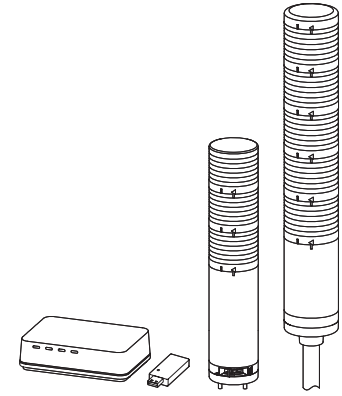

Thank you for purchasing Qlight's products. Please read this user manual carefully prior to installation and operation to ensure safe and correct use.



⚠ Precautions for Safety

Failure to follow the instructions below may cause a loss of life or serious physical injury.

1. During wiring or maintenance, please completely turn off the power of the product. (Failure to follow this may lead to an electric shock.)
2. Do not install the product in locations that subjects it to excessive dust or water other than the conditions designated by the IP protection ratings indicated for each product. (Failure to follow these instructions may cause a fire to the product, electric shock, physical injury, malfunction or damage to the product.)
3. Do not alter or repair this product. If maintenance or repair service is required, please contact your local Qlight contact point. (Failure to follow these instructions may lead to fire, electric shock, or product damage.)
4. Please apply the correct voltage to the product. (Failure to follow these instructions may lead to fire, electric shock, or product damage.)
5. When the product is applied to a condition that may impact lives or property, please make sure to have a double safety device. (Failure to follow this may cause damage to property, fire, electric shock and loss of life.)

⚠ Precautions for Correct Use

Failure to follow the proper instructions may cause damage to property, the product, or malfunction of the product that would void the warranty.

1. Please remove any objects that can interrupt ventilation around the product.
2. Please turn off the power of the product immediately if it fails to operate properly.
3. Carefully wire the product according to each product's specification.
4. Please be careful in preventing chemicals such as thinner, benzene, etc. in contact with the surface of the product.
5. Do not apply excessive force/impact to the product.
6. Failure to follow any of the instructions above may cause malfunction or damage to the product, fire, and electric shock.

Ordering Specifications

QTG60L-WIZ	3	24	RAG	LW18
[Model number]	[Layer count]	[Voltage]	[Color]	[Mounting option]
• QTG60L-WIZ	• 1 Layer	• 12-DC12V	R-Red	• (Blank)
• QTG60L-WIZ-BZ	• 2 Layers	• 24-DC24V	A-Amber	- Standard type
• QTG60LF-WIZ	• 3 Layers	• 110/220	G-Green	• Mounting type
• QTG60LF-WIZ-BZ	• 4 Layers	- AC110V~220V	B-Blue	- LB18 - LW18
• QTGA60L-WIZ	• 5 Layers		W-White	- QZ18 - SZ18
• QTGA60L-WIZ-BZ				- QL18 - SL18
• QTGA60LF-WIZ				- QLA18
• QTGA60LF-WIZ-BZ				

QTG70L-WIZ	3	110/220	RAG	LW24
[Model number]	[Layer count]	[Voltage]	[Color]	[Mounting option]
• QTG70L-WIZ	• 1 Layer	• 12-DC12V	R-Red	• (Blank)
• QTG70L-WIZ-BZ	• 2 Layers	• 24-DC24V	A-Amber	- Standard type
• QTG70LF-WIZ	• 3 Layers	• 110/220	G-Green	• Mounting type
• QTG70LF-WIZ-BZ	• 4 Layers	- AC110V~220V	B-Blue	- LB24 - LW24
• QTGA70L-WIZ	• 5 Layers		W-White	- QZ24 - SZ24
• QTGA70L-WIZ-BZ				- QL24 - SL24
• QTGA70LF-WIZ				- QLA24
• QTGA70LF-WIZ-BZ				



Please scan the QR code for more detailed product information.

www.qlight.com

Ordering Specifications





• QTG60ML-WIZ

QTG60ML-WIZ	3	110/220	RAG
[Model number]	[Layer count]	[Voltage]	[Color]
• QTG60ML-WIZ	• 1 Layer	• 12-DC12V	R-Red
• QTG60ML-WIZ-BZ	• 2 Layers	• 24-DC24V	A-Amber
• QTG60MLF-WIZ	• 3 Layers	• 110/220	G-Green
• QTG60MLF-WIZ-BZ	• 4 Layers	• -AC110V~220V	B-Blue
• QTGA60ML-WIZ	• 5 Layers		W-White
• QTGA60ML-WIZ-BZ			
• QTGA60MLF-WIZ			
• QTGA60MLF-WIZ-BZ			

• QTG70ML-WIZ

QTG70ML-WIZ	3	12	RAG
[Model number]	[Layer count]	[Voltage]	[Color]
• QTG70ML-WIZ	• 1 Layer	• 12-DC12V	R-Red
• QTG70ML-WIZ-BZ	• 2 Layers	• 24-DC24V	A-Amber
• QTG70MLF-WIZ	• 3 Layers	• 110/220	G-Green
• QTG70MLF-WIZ-BZ	• 4 Layers	• -AC110V~220V	B-Blue
• QTGA70ML-WIZ	• 5 Layers		W-White
• QTGA70ML-WIZ-BZ			
• QTGA70MLF-WIZ			
• QTGA70MLF-WIZ-BZ			

- Wireless LED Steady/Flashing Tower light has monitoring and controlling feature via PC that consists of USB DONGLE and GATEWAY.

Application Software	USB DONGLE	GATEWAY	ROUTER (wireless signaling device)
			

■ Description

No.	Item	Description
1	PC and mobile Application	PC Application would be a comprehensive control system by enabling the setting, monitoring, control and log analysis of the wireless signaling device. C# based application and software developer's API are provided. Mobile application can help to expand utility manager's coverage.
2	USB DONGLE (WIZ32)	USB DONGLE (WIZ32) can connect up to 32 wireless signaling device and is connected to the PC through a USB port in serial communication. It does not require a separate installation but simply insertion into a USB port for use. Note : USB DONGLE does NOT support Mobile application.
3	GATEWAY (GW768)	GATEWAY (GW768) can connect up to 32 wireless signaling device. Since it is possible to extend up to 24 GATEWAYs with a LAN ROUTER, they can connect up to 768 wireless signaling device. Note : GATEWAY supports Mobile application.
4	ROUTER (A wireless signal information device)	A wireless signaling device replaces an existing signaling device and converts the status data of production into wireless one so the control tower can control the status information of production equipment more easily and quickly. It functions to transmit (send) the status information of production equipment wirelessly and help the control tower control the wireless signaling device and send specified information to a worker.

Components of wireless system

1. Connection through USB DONGLE

- USB DONGLE can be easily inserted in the PC and this is a method suitable for building a small-sized single wireless network (up to 32 wireless control display lamps can be connected).

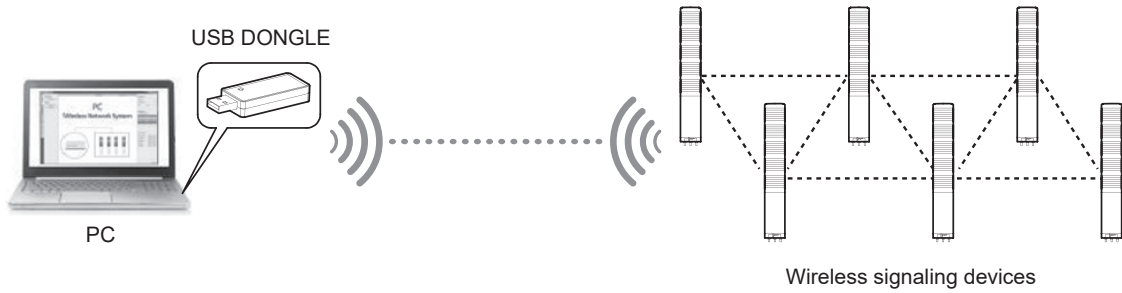

2. Connection through GATEWAY

- Up to 768 wireless control indicators can be connected by adopting multiple GATEWAYS. This is suitable for large-scale business sites.
- Smart phone can monitor or control the status of signaling devices.

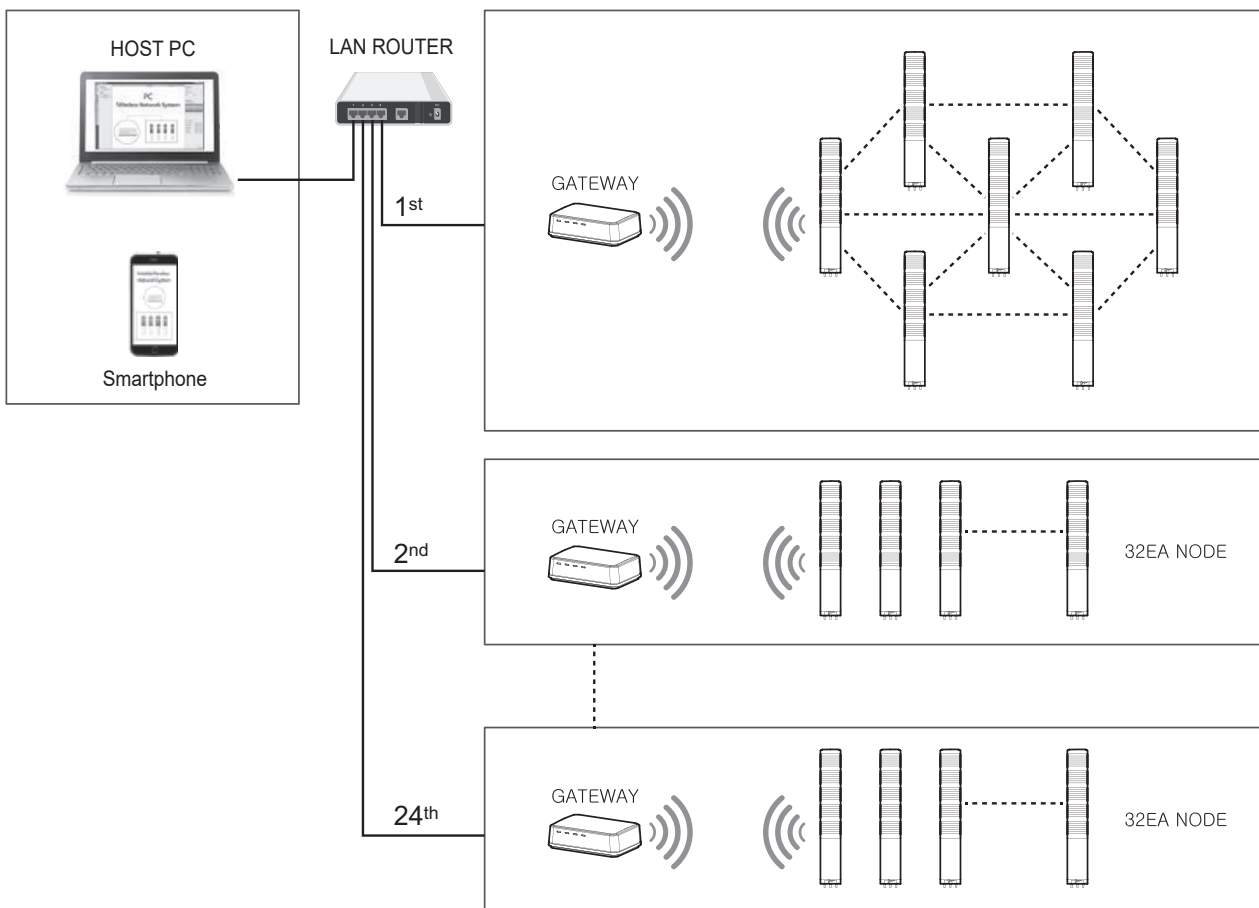

Information of wireless system

1. ROUTER(Wireless Signaling Device)

- The status information of the production equipment can be recognized by using an external contact and the status information are transmitted to USB DONGLE or GATEWAY. ROUTER can receive control signal from USB DONGLE or GATEWAY.
- Please refer to wireless information table on the label of the product.

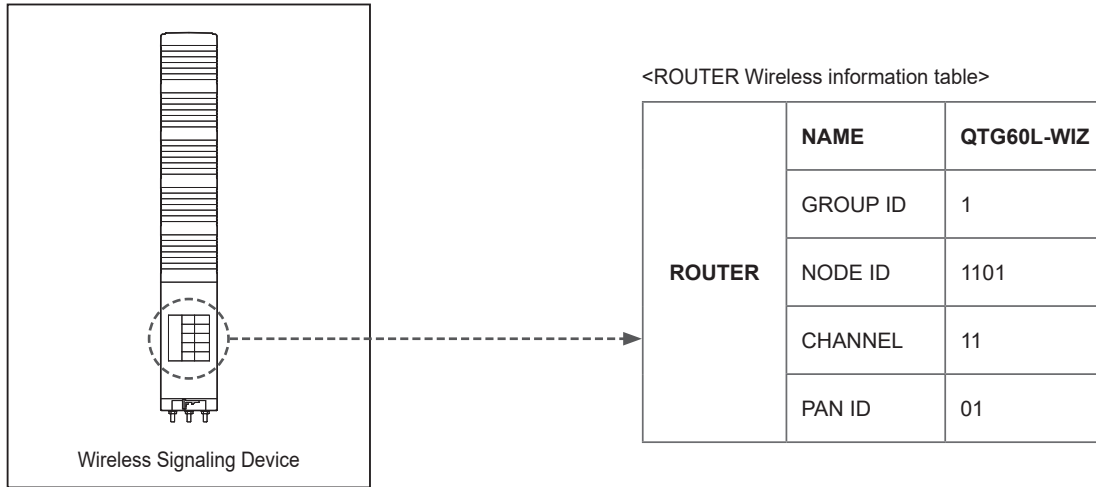

- ROUTER Wireless information table reference

	NAME	Model name
ROUTER	GROUP ID	<ul style="list-style-type: none"> • Designated GROUP ID by customer. Possible to set 1 to 24 GROUPS. • It must be set as same as receiver(USB DONGLE, GATEWAY).
	NODE ID	<ul style="list-style-type: none"> • Designated NODE ID(Product ID) by customer. 32 ID's are available. • Referring 1101, 11 represents channel number. NODE ID configuration is related to the channel number. (recommended)
	CHANNEL	<ul style="list-style-type: none"> • Can select up-to 16 channels from 11 to 26. It must be configured same as receivers(GATEWAY and USB DONGLE).
	PAN ID	<ul style="list-style-type: none"> • PAN ID can be set from 0 to 65535. It is wireless network identifier as an unique customer's number and designated by manufacturer.

2. USB DONGLE

- USB DONGLE is a wireless transmitter & receiver that is suitable for a small network with less than 32 wireless signaling devices.
- Please refer to wireless information table on the label of the product.

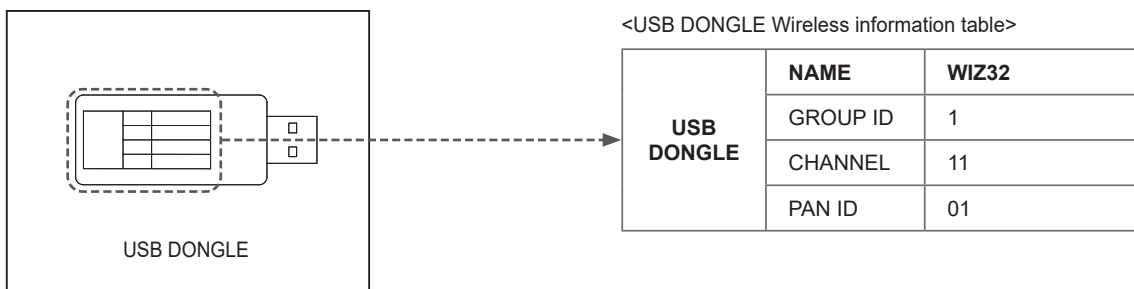

Information of wireless system

• USB DONGLE Wireless information table reference

USB DONGLE	NAME	Model name
	GROUP ID	<ul style="list-style-type: none"> • Designated GROUP ID by customer. Possible to set 1 to 24 GROUPS. • Possible to use single unit per PC. GROUP ID must NOT be same as GATEWAY. • It must be set as same as ROUTER(Wireless Signaling Device).
	CHANNEL	<ul style="list-style-type: none"> • Can select up-to 16 channels from 11 to 26. It must be configured same as ROUTER(Wireless Signaling Device).
	PAN ID	<ul style="list-style-type: none"> • PAN ID can be set from 0 to 65535. It is wireless network identifier as an unique customer's number and designated by manufacturer.

3. GATEWAY

- Suitable for large-scaled network over 32 wireless networks. One GATEWAY unit is a single group, can connect up to 24 groups.
- Support Smartphone Application
- Please refer to wireless information table on the label of the product.

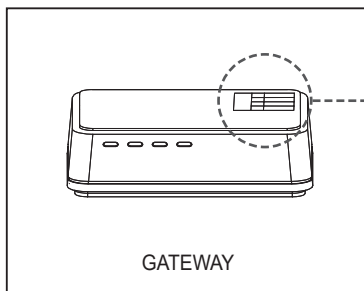

<GATEWAY wireless information table>

GATEWAY	NAME	GW768
	MAC ADDR.	0.35.183.XXX.XXX.XXX
	GROUP ID	1
	CHANNEL	11
	PAN ID	01

• GATEWAY Wireless information table reference









GATEWAY	NAME	Model name
	MAC ADDR.	<ul style="list-style-type: none"> • MAC ADDRESS designated by manufacturer. • MAC ADDRESS is used to set IP address and network information by searching GATEWAY in the network.
	GROUP ID	<ul style="list-style-type: none"> • Designated GROUP ID by customer. Possible to set 1 to 24 GROUPS. • GROUP ID must NOT be same as USB DONGLE. • It must be set as same as ROUTER(Wireless Signaling Device).
	CHANNEL	<ul style="list-style-type: none"> • Can select up-to 16 channels from 11 to 26. It must be configured same as ROUTER(Wireless Signaling Device).
	PAN ID	<ul style="list-style-type: none"> • Pan ID can be set from 0 to 65535. It is wireless network identifier as an unique customer's number and designated by manufacturer.

Information of wireless system

4. Installation of PC Application

(1) SERIAL TO USB DRIVER installation

- There are two options of receiving & controlling the wireless signaling device such as USB DONGLE and USB interface with the GATEWAY. In both cases, 'USB to serial device driver' should be installed (download it from Qlight website or <http://blog.qlight.com>).
- Select x64 or x86 EXE. file depending on your OS type.
- Silicon Labs' drivers are provided as a device driver.

 x64	2020-03-10	11:25	
 x86	2020-03-10	11:25	
 CP210xVCPInstaller_x64	2017-09-28	2:58	1,026KB
 CP210xVCPInstaller_x86	2017-09-28	2:58	903KB
 dpinst	2017-09-28	2:45	12KB
 SLAB_License_Agreement_VCP_Windows	2017-09-28	2:46	9KB
 slabvcp	2017-10-11	2:52	11KB
 slabvcp	2017-10-11	2:52	15KB
 v6-7-5-driver-release-notes	2017-10-17	7:49	14KB

- After the installation completes, check if COM# Port is displayed in the Device Manager of PC before connecting the USB DONGLE or the GATEWAY through a USB PORT.
- COM# can vary depending on the PC environment.



(2) Installation of PC Application

- The PC application is used to monitor, set, and control the status information of a wireless signaling device.
- In case of using C# Library, please refer to the Library User Manual which is provided separately.
- Please download the PC Application from our website and install it.

 QlightManagerv2.48 <= Please run .exe file. Software VERSION may be upgraded without notice.

**For the installation instruction and usage, please refer to manual.

(3) For the usage of API using DLL, please refer to manual.

Product Specifications

• QTG60L-WIZ

Model number	Layer count	Voltage	Current	Certificate	Weight	Color
QTG60L-WIZ Steady QTG60L-WIZ-BZ Steadyw/ built-in buzzer	1	DC12V DC24V AC110V~220V	0.150A 0.110A Max. 0.070A		0.44kg 0.44kg 0.54kg	R-Red
QTG60LF-WIZ Steady/Flashing QTG60LF-WIZ-BZ Steady/Flashing w/ built-in buzzer	2	DC12V DC24V AC110V~220V	0.240A 0.160A Max. 0.100A		0.53kg 0.53kg 0.63kg	R-Red G-Green
QTGA60L-WIZ Steady QTGA60L-WIZ-BZ Steadyw/ built-in buzzer	3	DC12V DC24V AC110V~220V	0.330A 0.220A Max. 0.120A		0.61kg 0.61kg 0.56kg	R-Red A-Amber G-Green
QTGA60LF-WIZ Steady/Flashing QTGA60LF-WIZ- BZ	4	DC12V DC24V AC110V~220V	0.420A 0.270A Max. 0.150A		0.70kg 0.70kg 0.80kg	R-Red A-Amber G-Green B-Blue
Steady/Flashing w/ built-in buzzer	5	DC12V DC24V AC110V~220V	0.510A 0.320A Max. 0.170A		0.78kg 0.78kg 0.88kg	R-Red A-Amber G-Green B-Blue W-White

* FCC, CE compliant : DC24V : DC24V, AC110V/220V

* KC : DC24V

* Coverage of AC model is AC100VAC to 240VAC.

• QTG70L-WIZ

Model number	Layer count	Voltage	Current	Certificate	Weight	Color
QTG70L-WIZ Steady QTG70L-WIZ-BZ Steady w/ built-in buzzer	1	DC12V DC24V AC110V~220V	0.150A 0.110A Max. 0.070A		0.57kg 0.57kg 0.67kg	R-Red
QTG70LF-WIZ Steady/Flashing QTG70LF-WIZ-BZ Steady/Flashing w/ built-in buzzer	2	DC12V DC24V AC110V~220V	0.240A 0.160A Max. 0.100A		0.69kg 0.69kg 0.79kg	R-Red G-Green
QTGA70L-WIZ Steady QTGA70L-WIZ-BZ Steadyw/ built-in buzzer	3	DC12V DC24V AC110V~220V	0.330A 0.220A Max. 0.120A		0.84kg 0.84kg 0.94kg	R-Red A-Amber G-Green
QTGA70LF-WIZ Steady/Flashing QTGA70LF-WIZ- BZ	4	DC12V DC24V AC110V~220V	0.420A 0.270A Max. 0.150A		0.99kg 0.99kg 1.09kg	R-Red A-Amber G-Green B-Blue
Steady/Flashing w/ built-in buzzer	5	DC12V DC24V AC110V~220V	0.510A 0.320A Max. 0.170A		1.23kg 1.23kg 1.32kg	R-Red A-Amber G-Green B-Blue W-White

* FCC, CE compliant : DC24V : DC24V, AC110V/220V

* KC : DC24V

* Coverage of AC model is AC100VAC to 240VAC.

• QTG60ML-WIZ

Model number	Layer count	Voltage	Current	Certificate	Weight	Color
QTG60ML-WIZ Steady QTG60ML-WIZ-BZ Steadyw/ built-in buzzer	1	DC12V DC24V AC110V~220V	0.150A 0.110A Max. 0.070A		0.29kg 0.29kg 0.39kg	R-Red
QTG60MLF-WIZ Steady/Flashing QTG60MLF-WIZ- BZ	2	DC12V DC24V AC110V~220V	0.240A 0.160A Max. 0.100A		0.37kg 0.37kg 0.47kg	R-Red G-Green
QTGA60ML-WIZ Steady QTGA60ML-WIZ- BZ	3	DC12V DC24V AC110V~220V	0.330A 0.220A Max. 0.120A		0.46kg 0.46kg 0.56kg	R-Red A-Amber G-Green
QTGA60MLF-WIZ Steady/Flashing QTGA60MLF-WIZ- BZ	4	DC12V DC24V AC110V~220V	0.420A 0.270A Max. 0.150A		0.54kg 0.54kg 0.64kg	R-Red A-Amber G-Green B-Blue
Steady/Flashing w/ built-in buzzer	5	DC12V DC24V AC110V~220V	0.510A 0.320A Max. 0.170A		0.62kg 0.62kg 0.72kg	R-Red A-Amber G-Green B-Blue W-White

* FCC, CE compliant : DC24V : DC24V, AC110V/220V

* KC : DC24V

• QTG70ML-WIZ

Model number	Layer count	Voltage	Current	Certificate	Weight	Color
QTG70ML-WIZ Steady QTG70ML-WIZ-BZ Steadyw/ built-in buzzer	1	DC12V DC24V AC110V~220V	0.150A 0.110A Max. 0.070A		0.45kg 0.45kg 0.55kg	R-Red
QTG70MLF-WIZ Steady/Flashing QTG70MLF-WIZ- BZ	2	DC12V DC24V AC110V~220V	0.240A 0.160A Max. 0.100A		0.59kg 0.59kg 0.69kg	R-Red G-Green
QTGA70ML-WIZ Steady QTGA70ML-WIZ- BZ	3	DC12V DC24V AC110V~220V	0.330A 0.220A Max. 0.120A		0.80kg 0.80kg 0.90kg	R-Red A-Amber G-Green
QTGA70MLF-WIZ Steady/Flashing QTGA70MLF-WIZ- BZ	4	DC12V DC24V AC110V~220V	0.420A 0.270A Max. 0.150A		0.95kg 0.95kg 1.05kg	R-Red A-Amber G-Green B-Blue
Steady/Flashing w/ built-in buzzer	5	DC12V DC24V AC110V~220V	0.510A 0.320A Max. 0.170A		1.10kg 1.10kg 1.20kg	R-Red A-Amber G-Green B-Blue W-White

* FCC, CE compliant : DC24V : DC24V, AC110V/220V

* KC : DC24V

• QTG60ML-WIZ / QTG60L-WIZ

QTG60ML-WIZ : AC/DC
 QTG60MLF-WIZ : AC/DC

QTG60ML-WIZ-BZ : AC/DC
 QTG60MLF-WIZ-BZ : AC/DC

QTG60L-WIZ : AC/DC
 QTG60LF-WIZ : AC/DC

QTG60L-WIZ-BZ : AC/DC
 QTG60LF-WIZ-BZ : AC/DC

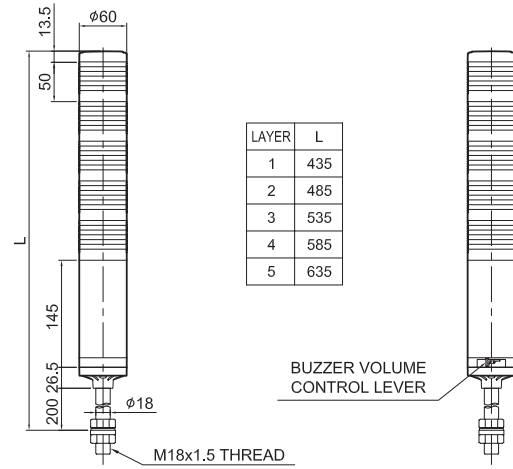
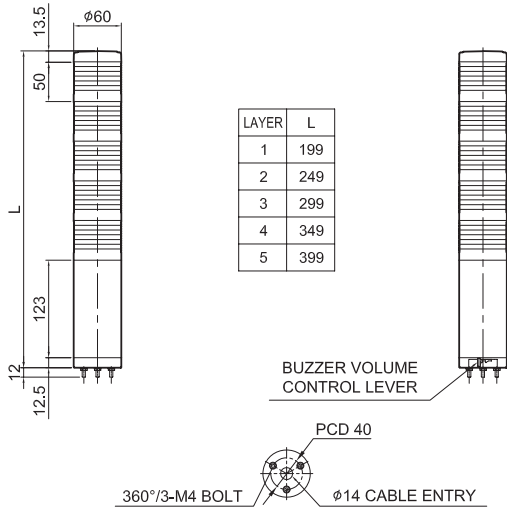

• QTG70ML-WIZ / QTG70L-WIZ

QTG70ML-WIZ : AC/DC
 QTG70MLF-WIZ : AC/DC

QTG70ML-WIZ-BZ : AC/DC
 QTG70MLF-WIZ-BZ : AC/DC

QTG70L-WIZ : AC/DC
 QTG70LF-WIZ : AC/DC

QTG70L-WIZ-BZ : AC/DC
 QTG70LF-WIZ-BZ : AC/DC

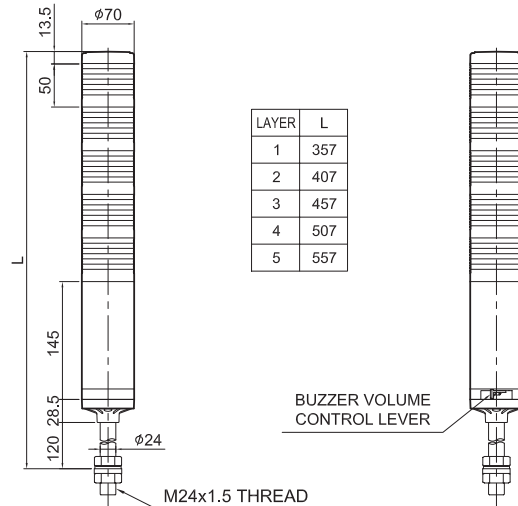
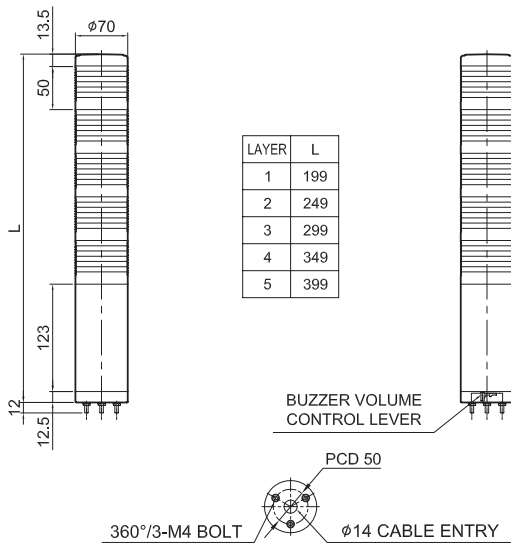

• GATEWAY

GATEWAY (GW768)

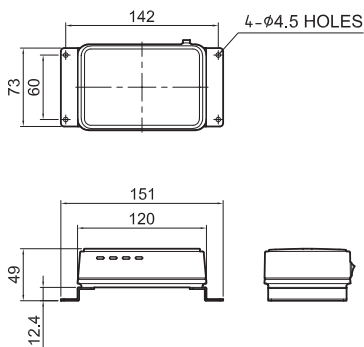

• USB DONGLE

USB DONGLE (WIZ32)

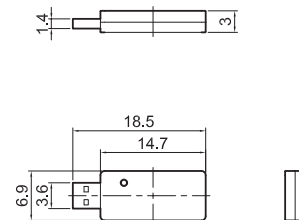

Wiring Instructions

- Please wire the product by referring below instruction.
- You can monitor status of tower light and control them via wireless network.

Wiring using external contact	
<p>AC/DC Steady</p> <p>QTG60ML-WIZ QTG60L-WIZ QTG70ML-WIZ QTG70L-WIZ</p>	<p>External contact</p> <p>Layer 1 Layer 2 Layer 3 Layer 4 Layer 5 Buzzer Steady</p> <p>Red Amber Green Blue White Brown</p> <p>Black White Black</p> <p>Fuse Power</p> <ul style="list-style-type: none"> • QTG(A) □□(M)L-WIZ - Same wiring including buzzer type • QTG □□L <ul style="list-style-type: none"> └ Lens diameter 60(60mm) : QTG60(M)L └ 70(70mm) : QTG70(M)L
<p>DC Steady/ Flashing</p> <p>QTG60ML-WIZ QTG60L-WIZ QTG70ML-WIZ QTG70L-WIZ</p>	<p>External contact</p> <p>Layer 1 Layer 2 Layer 3 Layer 4 Layer 5 Buzzer Flash! Steady</p> <p>Red Amber Green Blue White Brown</p> <p>Black Violet White Black</p> <p>Common</p> <p>Fuse Power</p> <ul style="list-style-type: none"> • QTG(A) □□(M)L-WIZ - Same wiring including buzzer type • QTG □□L <ul style="list-style-type: none"> └ Lens diameter 60(60mm) : QTG60(M)L └ 70(70mm) : QTG70(M)L
<p>AC Steady/ Flashing</p> <p>QTG60ML-WIZ QTG60L-WIZ QTG70ML-WIZ QTG70L-WIZ</p>	<p>External contact</p> <p>Layer 1 Layer 2 Layer 3 Layer 4 Layer 5 Buzzer Flash! Steady</p> <p>Red Amber Green Blue White Brown</p> <p>Black Violet White Black</p> <p>Common</p> <p>Fuse Power</p> <ul style="list-style-type: none"> • QTG(A) □□(M)L-WIZ - Same wiring including buzzer type • QTG □□L <ul style="list-style-type: none"> └ Lens diameter 60(60mm) : QTG60(M)L └ 70(70mm) : QTG70(M)L

- DC steady type cable specification : External power/ signal line - UL1007 AWG22(0.3sq) 400mm.
- AC steady, AC/DC steady/flashing type cable specification : External power line - UL1015 AWG18(0.75sq) × 2C 400mm, External signal line - UL1007 AWG22(0.3sq) 400mm

Wiring Instructions

- Wiring to transistor, use the NPN transistor. Please wire properly based on wiring instructions below.

Wiring using transistor	
<p>AC/DC Steady</p> <p>QTG60ML-WIZ QTG60L-WIZ QTG70ML-WIZ QTG70L-WIZ</p>	<p>External Transistor-NPN</p> <p>Red Amber Green Blue White Brown Black White Black</p> <p>Layer 1 Layer 2 Layer 3 Layer 4 Layer 5 Buzzer Common Fuse Power</p> <ul style="list-style-type: none"> • QTG(A) □□ (M)L-WIZ - Same wiring including buzzer type • QTG □□ L <ul style="list-style-type: none"> □ Lens diameter 60(60mm) : QTG60(M)L □ Lens diameter 70(70mm) : QTG70(M)L
<p>DC Steady/ Flashing</p> <p>QTG60ML-WIZ QTG60L-WIZ QTG70ML-WIZ QTG70L-WIZ</p>	<p>External Transistor-NPN</p> <p>Red Amber Green Blue White Brown Violet Black White Black</p> <p>Layer 1 Layer 2 Layer 3 Layer 4 Layer 5 Buzzer Common Fuse Power</p> <ul style="list-style-type: none"> • QTG(A) □□ (M)L-WIZ - Same wiring including buzzer type • QTG □□ L <ul style="list-style-type: none"> □ Lens diameter 60(60mm) : QTG60(M)L □ Lens diameter 70(70mm) : QTG70(M)L
<p>AC Steady/ Flashing</p> <p>QTG60ML-WIZ QTG60L-WIZ QTG70ML-WIZ QTG70L-WIZ</p>	<p>External Transistor-NPN</p> <p>Red Amber Green Blue White Brown Violet Black White Black</p> <p>Layer 1 Layer 2 Layer 3 Layer 4 Layer 5 Buzzer Common Fuse Power</p> <ul style="list-style-type: none"> • QTG(A) □□ (M)L-WIZ - Same wiring including buzzer type • QTG □□ L <ul style="list-style-type: none"> □ Lens diameter 60(60mm) : QTG60(M)L □ Lens diameter 70(70mm) : QTG70(M)L

- DC steady type cable specification : External power/ signal line - UL1007 AWG22(0.3sq) 400mm.
- AC steady, AC/DC steady/flashing type cable specification : External power line - UL1015 AWG18(0.75sq) × 2C 400mm,
External signal line - UL1007 AWG22(0.3sq) 400mm

Parts Definition

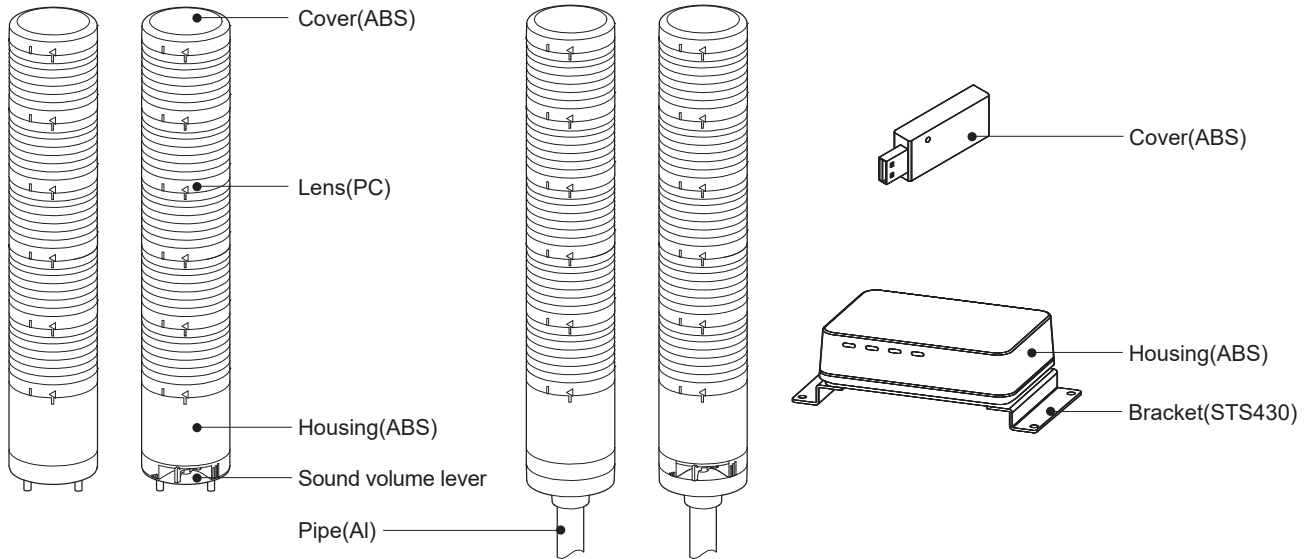

How to Change Lens Kit

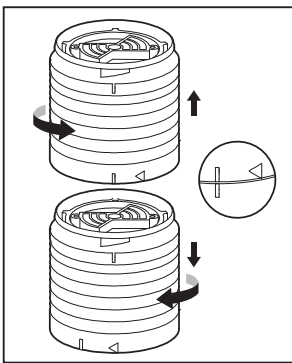

- Disassembling lens kits
- ① Twist the upper lens kit in a counter-wise direction so the "I" mark from both kits align.
- ② Disassemble by removing the upper lens kit from the lower one.

※ Cautions

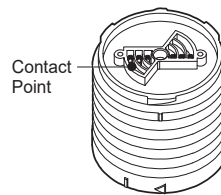

Lens modules are connected through cone-shaped contact point. In case the contact point is damaged, it may cause a contact failure.

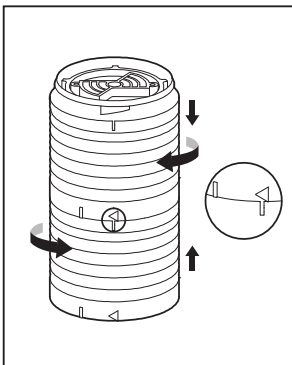

- Assembling lens kits
- ① Put the two lens kits together by aligning the upper lens' "I" mark and the lower lens' "I" mark together.
- ② Lock the two kits by twisting the upper lens kit in a counter-wise direction so the upper lens' "◁" mark aligns with the lower lens' "I" mark.

Installation Environment and Protection Rating

- This product is designed for indoor use with protection rating of IP65(standard type) and IP54(buzzer type).
- If the product is installed in locations that subject it to excessive dust or water other than the designated IP protection rating indicated(IP65), it may cause malfunction or damage to the product.
- For further information, please visit our website(www.qlight.com).

Buzzer Sound Volume Adjustment Instructions

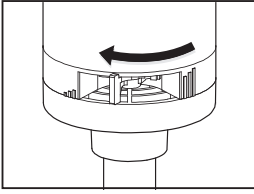

Buzzer volume is reduced by sliding the volume control lever to the left as show in the diagram to the left.
(Min. $65\pm 4\text{dB/m}$)

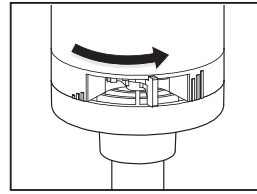

Raise/ Increase the buzzer volume by sliding the control lever to the right as shown in the diagram to the left.
(Max. $85\pm 4\text{dB/m}$)

Mounting Hole Specifications

■ QTG60ML-WIZ / QTG70ML-WIZ - Direct Mounting Type Model

① Machine holes on the mounting surface referring to the diagram below.

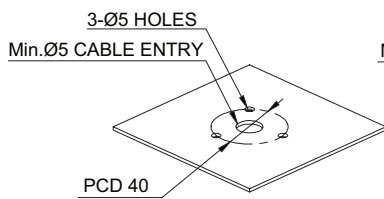

QTG60ML-WIZ

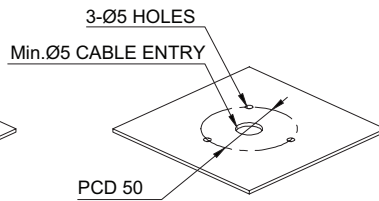

QTG70ML-WIZ

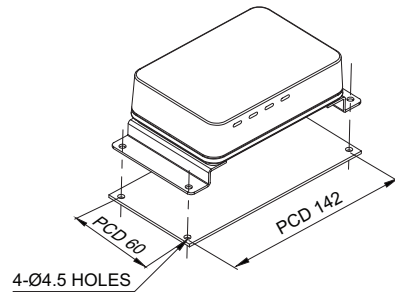

GW768

② Remove the flange nuts from bolts and place the product through the mounting surface holes.

③ Fasten the flange nuts on the opposite side of the mounting surface until the product is tightened securely.

Mounting Accessories (Sold Separately)

• Please refer to the dimensions below for installation of mounting brackets.

■ QTG60ML-WIZ/ QTG70ML-WIZ - Direct Mounting Type Model

	Dimensions	
QTG60 series	<p>TWS45</p>	<p>TWA45</p>
QTG70 series	<p>TWS80</p>	<p>TWA80</p>

■ QTG60L-WIZ - Pole Mounting Type Model

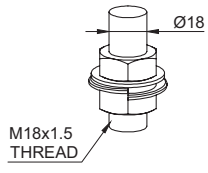
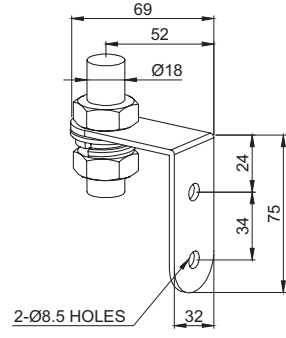
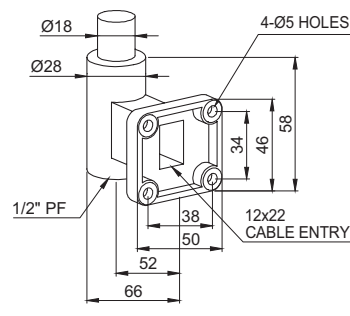
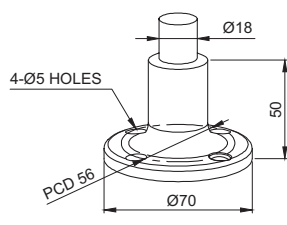
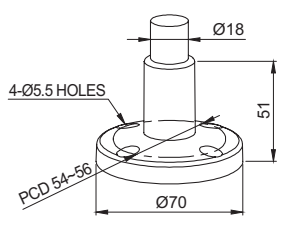
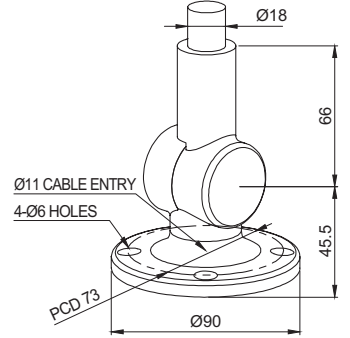
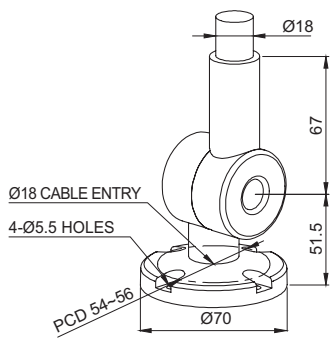
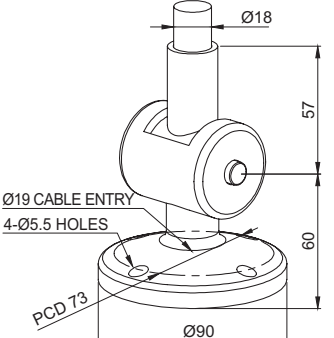
Dimensions	
<p>QTG60 series</p>  <p>M18x1.5 THREAD</p> <p>Ø18</p>	 <p>69</p> <p>52</p> <p>Ø18</p> <p>2-Ø8.5 HOLES</p> <p>75</p> <p>24</p> <p>34</p> <p>32</p> <p>LB18</p>
<p>18mm SCREW & NUT</p>  <p>Ø18</p> <p>Ø28</p> <p>4-Ø5 HOLES</p> <p>1/2" PF</p> <p>12x22 CABLE ENTRY</p> <p>58</p> <p>34</p> <p>46</p> <p>52</p> <p>50</p> <p>38</p> <p>66</p> <p>LW18</p>	 <p>Ø18</p> <p>4-Ø5 HOLES</p> <p>PCD 56</p> <p>Ø70</p> <p>50</p> <p>SZ18</p>
 <p>Ø18</p> <p>4-Ø5.5 HOLES</p> <p>PCD 54-56</p> <p>Ø70</p> <p>51</p> <p>QZ18</p>	 <p>Ø18</p> <p>Ø11 CABLE ENTRY</p> <p>4-Ø6 HOLES</p> <p>PCD 73</p> <p>Ø90</p> <p>66</p> <p>45.5</p> <p>SL18</p>
 <p>Ø18</p> <p>Ø18 CABLE ENTRY</p> <p>4-Ø5.5 HOLES</p> <p>PCD 54-56</p> <p>Ø70</p> <p>67</p> <p>51.5</p> <p>QL18</p>	 <p>Ø18</p> <p>Ø19 CABLE ENTRY</p> <p>4-Ø5.5 HOLES</p> <p>PCD 73</p> <p>Ø90</p> <p>57</p> <p>60</p> <p>QLA18</p>

■ QTG70L-WIZ - Pole Mounting Type Model

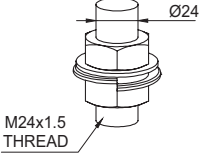
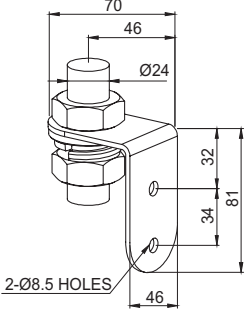
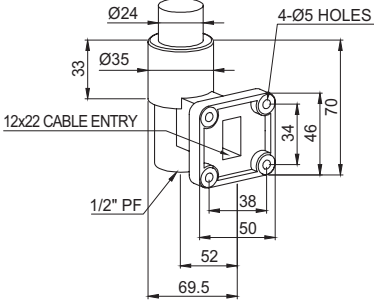
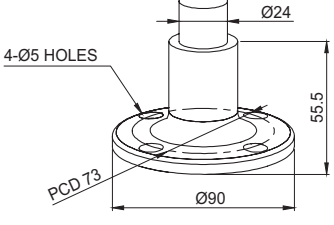
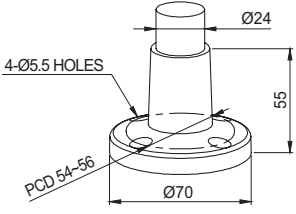
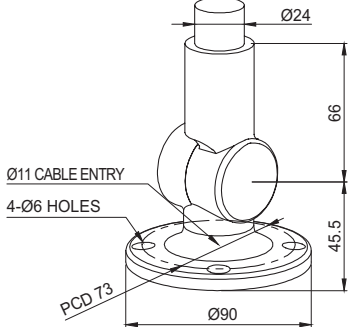
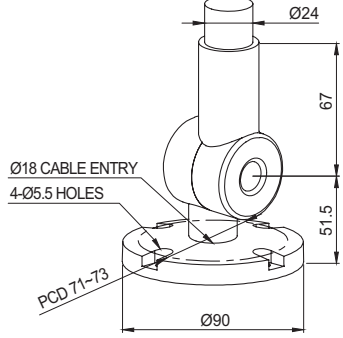
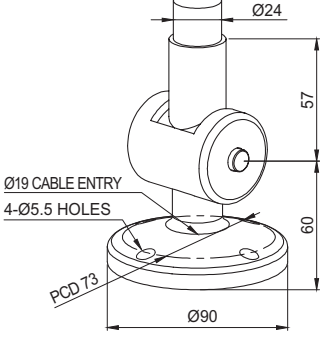
Dimensions	
<p>QTG70 series</p>	 <p>24mm SCREW & NUT</p>  <p>LB24</p>
 <p>LW24</p>	 <p>SZ24</p>
 <p>QZ24</p>	 <p>SL24</p>
 <p>QL24</p>	 <p>QLA24</p>

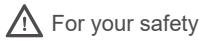

For your safety

Specification and dimensions listed in this catalogue subject to change without notice for product quality improvement.
The newest product information is available on our website.(www.qlight.com)
Please read the instruction manual attached to the product carefully before installation and use.

Qlight Co., Ltd. www.qlight.com | trade@qlight.com

Head Office | Suite #1510, STX-V Tower, 128 Gasan digital 1-ro, Geumcheon-gu, Seoul, Korea

Tel. +82-2-2679-6152(Toll free. +82-80-328-2222) Fax. +82-2-2679-6154

Factory | 185-25, Mukbang-ro, Sangdong-myeon, Gimhae-si, Gyeongsangnamdo, Korea Tel. +82-55-328-1111(Toll free. +82-80-328-1111)

Qlight OverSEAs Sales Dept | 704 Nakdong-daero, Sasang-gu, Busan, Korea(Eomgung-Dong) Tel : +82-51-620-4100

Qlight Public Relations & Marketing Team Office | 704 Nakdong-daero, Sasang-gu, Busan, Korea(Eomgung-Dong) Tel. +82-51-245-0017

Qlight USA, Inc. www.qlight.com www.qlightusa.com | sales@qlightusa.com

3003 North First Street, Suite #341, San Jose, CA 95134 USA Tel. +1-408-519-5740 Fax. +1-408-519-5739

SHANGHAI Qlight Electronic Co., Ltd. www.qlight.com www.qlightcn.com | qlightcn@qlight.com

China Factory/ Shanghai Sales Office | #19, Nanda Road, Baoshan Area, Shanghai, China Tel. +86-21-6651-7100 Fax. +86-21-6315-3929

China Factory Site 2 (Qidong) | #33, Haiyan Road, Qidong High-tech Industrial Development Zone, Qidong, Jiangsu Province, China

Tel +86-513-8384-9999 Fax +86-513-8384-9910

Qlightec

Innovation in Alarm & Signal

Product Operation Inquiry / Customer Support +82-51-620-4100

You can expect prompt service if you have exact information such as model name, symptom, telephone number and address.

※ ALL PRODUCT, PRODUCT SPECIFICATIONS AND DATA ARE SUBJECT TO CHANGE WITHOUT NOTICE TO IMPROVE RELIABILITY, FUNCTION OR DESIGN OR OTHERWISE.

Head office : Suite #1510, STX-V Tower, 128 Gasan digital 1-ro, Geumcheon-gu, Seoul, Korea (Postal Code : 08507)

Factory : 185-25, Mukbang-Ro, Sangdong-Myeon, Gimhae-Si, Gyeongsangnam-Do, Korea (Postal Code : 50805)

www.qlight.com

EN - QTG60L-WIZ - 2106A