



Solutions for
WIND

Product Range

 **Bonfiglioli**



Solutions for

CONTENTS

WIND

WIND	5
MILESTONES	6
SUSTAINABILITY ROADMAP	8
AIMING FOR SUSTAINABILITY	10
INTEGRATED SOLUTIONS WITH MOTORS AND INVERTERS	12
700TW SERIES	14
Overall dimensions	15
Pitch drive.....	16
Yaw drive.....	17
BN/M, BE/ME, BX/MX SERIES	18
BMD SERIES	19
BSR SERIES	20
ACTIVE CUBE SERIES	21
AXIAVERT SERIES	22
DGM SERIES	23
THE BONFIGLIOLI IOT PLATFORM	24
OUR GOAL: LCOE REDUCTION	28
OUR STRIVING FOR THE FUTURE	32
OUR CONSTANT AMBITION	33
OUR GLOBAL PRESENCE	34

Engineering Sustainability

APQP 4 Wind
Company Member



WWW.BONFIGLIOLI.COM

WIND

INNOVATIVE SOLUTIONS FOR RENEWABLE ENERGIES

For almost 45 years, Bonfiglioli has been supplying dedicated integrated solutions to the wind industry. The combined expertise in the designing and manufacturing of gearboxes in association with years of experience in applications on wind turbines has enabled Bonfiglioli to become a global top player.

One in three wind turbines globally uses a Bonfiglioli gearbox.

The result is a complete package dedicated to the wind energy sector which seamlessly enables the control of energy generation, from rotor blade positioning with a pitch drive to nacelle orientation with a yaw drive.

Bonfiglioli has produced a completely integrated inverter solution for yaw drives and re-generator inverters to feed the electricity created by the wind turbine into the power grid.

Working closely with Customers to develop tailor-made applications, Bonfiglioli uses its flexibility to deliver reliable, superior performance products, which comply with all worldwide standards.

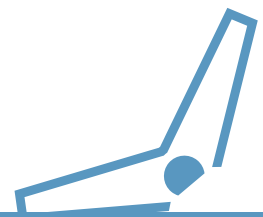

MILESTONES

ALMOST 45 YEARS OF EXPERTISE IN THE WIND INDUSTRY

1980

- > **START OF WIND PRODUCTS**
- > Collaboration with “pioneers” of wind energy, Nordtank and Micon

MID 90'S

- > Tailor made reinforced planetary gearboxes for yaw and pitch drive
- > **Turbines up to 1.0+ MW**

2014

Yaw and pitch drive local production in Brazil

2013

Turbines up to 7.0 MW

2012

Bonfiglioli develops lean concept in product design

2016

- > **Introduces real time load measurement by torque sensor**
- > Bonfiglioli market share in wind exceeds 35%

+35%

2018

Further expansion of yaw and pitch drives up to 10 MW turbines

2019

- > Yaw and pitch permanent magnet motor
- > **Bonfiglioli introduces IoT solution for condition monitoring system**

2000

Bonfiglioli integrates self-braking motors in planetary gearboxes

2003

- › First supply of Bonfiglioli inverters for Yaw control
- › **Yaw inverter local production in Germany**

2005

Turbines up to 5.0 MW

2011

Yaw and pitch drive local production in China

2008

- › **Yaw and pitch motor local production in Vietnam**
- › Bonfiglioli market share in wind exceeds 30%

+30%

2006

Yaw and pitch drive local production in India

2020

- › **APQP4Wind Certification**
- › **Turbines up to 15.0 MW**
- › Bonfiglioli develops Series 700TW Yaw Drive with integrated motoinverter

2022

- › Yaw drive offshore with integrated moto-inverter: 3 in 1 solution
- › Pitch drive motor offshore in permanent magnet configuration

2024

- › **Yaw and Pitch local production in Turkey**



SUSTAINABILITY ROADMAP

WE HAVE A PLAN

 Definition of annual targets to improve safety indicators

 Reduction of packaging waste by 2030

 Inventory of scope 3 emissions

2022

Life Cycle Assessment of Wind segment products

2023



Sustainability Policy

Supplier Code of Conduct

20

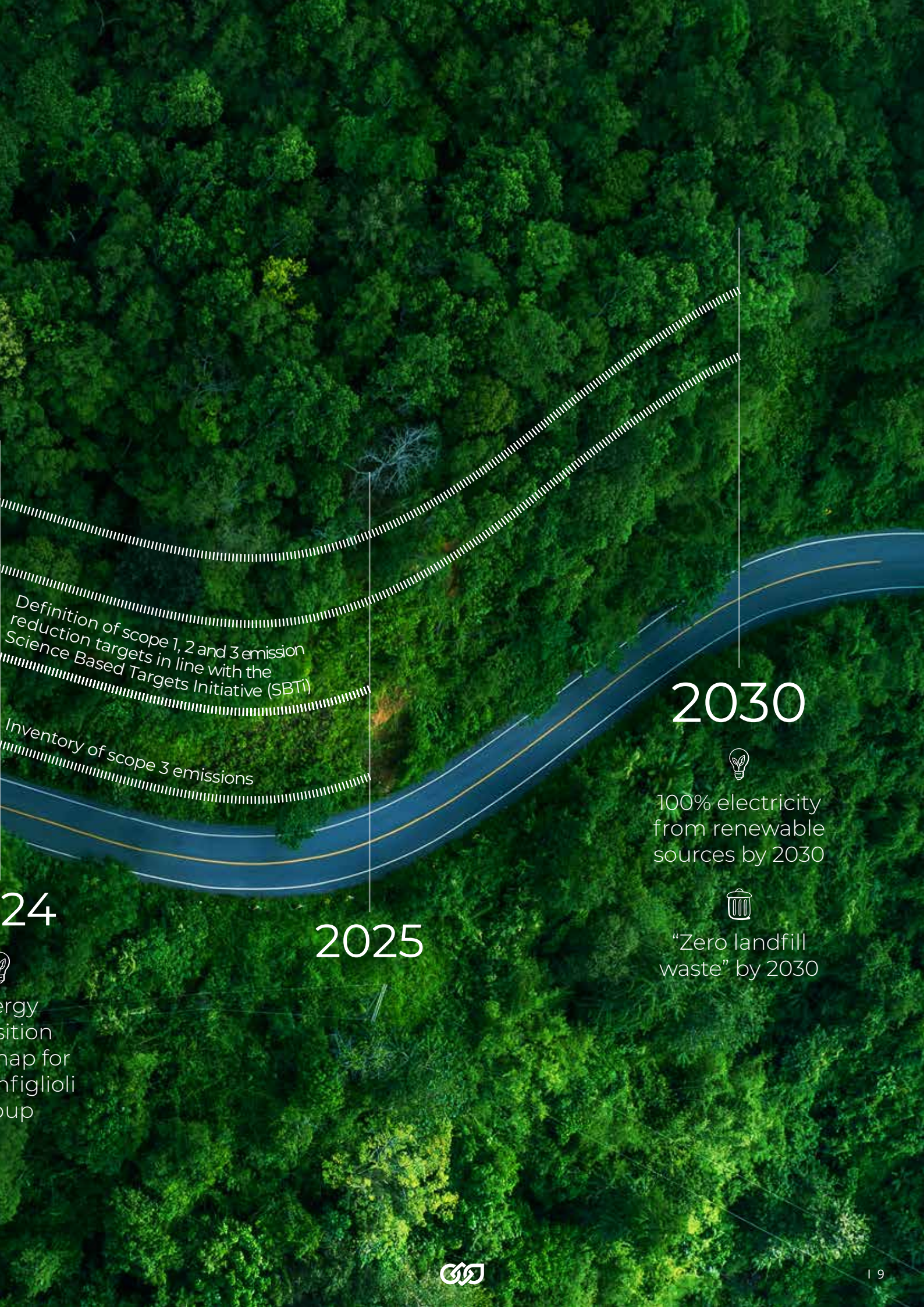

Energy Transition Roadmap for the Board Group



Definition of scope 1, 2 and 3 emission reduction targets in line with the Science Based Targets Initiative (SBTi)

Inventory of scope 3 emissions

24

Energy transition map for the group

2025

2030



100% electricity from renewable sources by 2030



"Zero landfill waste" by 2030

AIMING FOR SUSTAINABILITY

ESG: ENVIRONMENT, SOCIAL & GOVERNANCE

OUR APPROACH

A true corporate manifesto that outlines clear and defined objectives, based on ESG principles.



ENVIRONMENTAL



SOCIAL



GOVERNANCE

WE ARE COMPLIANT!

To ensure we can accurately measure the Group's impact on the environment, we comply with various international industry frameworks.



OUR COMMITMENT TO THE ENVIRONMENT



2,867,927 kWh

ENERGY CONSUMPTION FROM RENEWABLE SOURCES



-13%

DIRECT CONSUMPTION FROM NON-RENEWABLE SOURCES (2023 VS 2021)

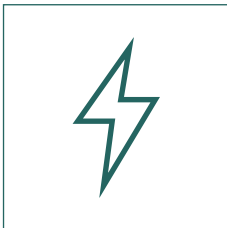

+15%

SELF-GENERATED ELECTRICITY AND ELECTRICITY ACQUIRED FROM RENEWABLE SOURCES (2023 vs 2021)

Source: sustainability report 2023

EFFECTIVE SUPPLY CHAIN MANAGEMENT FOR A REDUCED FOOTPRINT

We are committed to implementing specific actions to reduce our environmental footprint along the entire production chain. From sustainable design to the conscious selection of suppliers and raw materials, the use of clean technologies in our plants, and the proper handling of all products through to the end of their life cycle, we are adapting to be able to produce and distribute products that respond to our customers' needs in a more sustainable way.



12,083 TONS

TOTAL DUMPED WASTE



-30,2%

WASTE SENT TO LANDFILL



80%

NON-HAZARDOUS WASTE



30,3%

WASTE SENT FOR RECYCLING OR REUSE

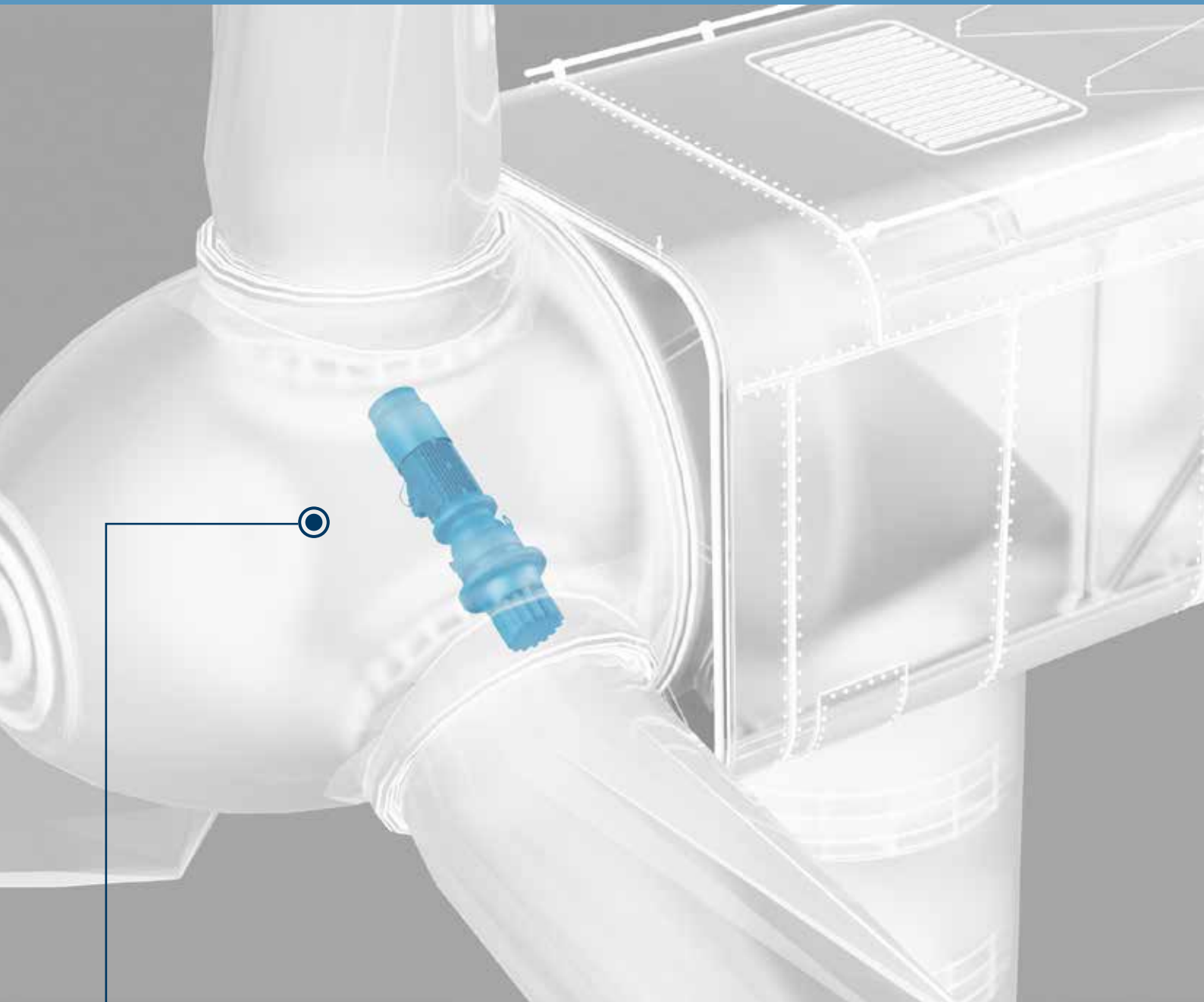

1

PITCH DRIVES

WITH PERMANENT MAGNET OR ASYNCHRONOUS INDUCTION MOTORS

Bonfiglioli pitch drives' wide range of output torques and gearbox sizes expertly meet the OEM requirements of wind turbines. Completely custom-made, this product offers a flexible solution to wind turbine manufacturers. Additionally, we provide solutions with double input seals and a splined coupling, ensuring enhanced durability and performance in demanding conditions. Recent new features like the integrated load cell and the torque limiter show that Bonfiglioli always thinks outside the box and continuously searches for the most cost-effective solution.

- > **BN, BE & BX Series**
Asynchronous induction motors
- > **BMD Series**
Permanent magnet motors
- > **BSR Series**
Synchronous reluctance motor

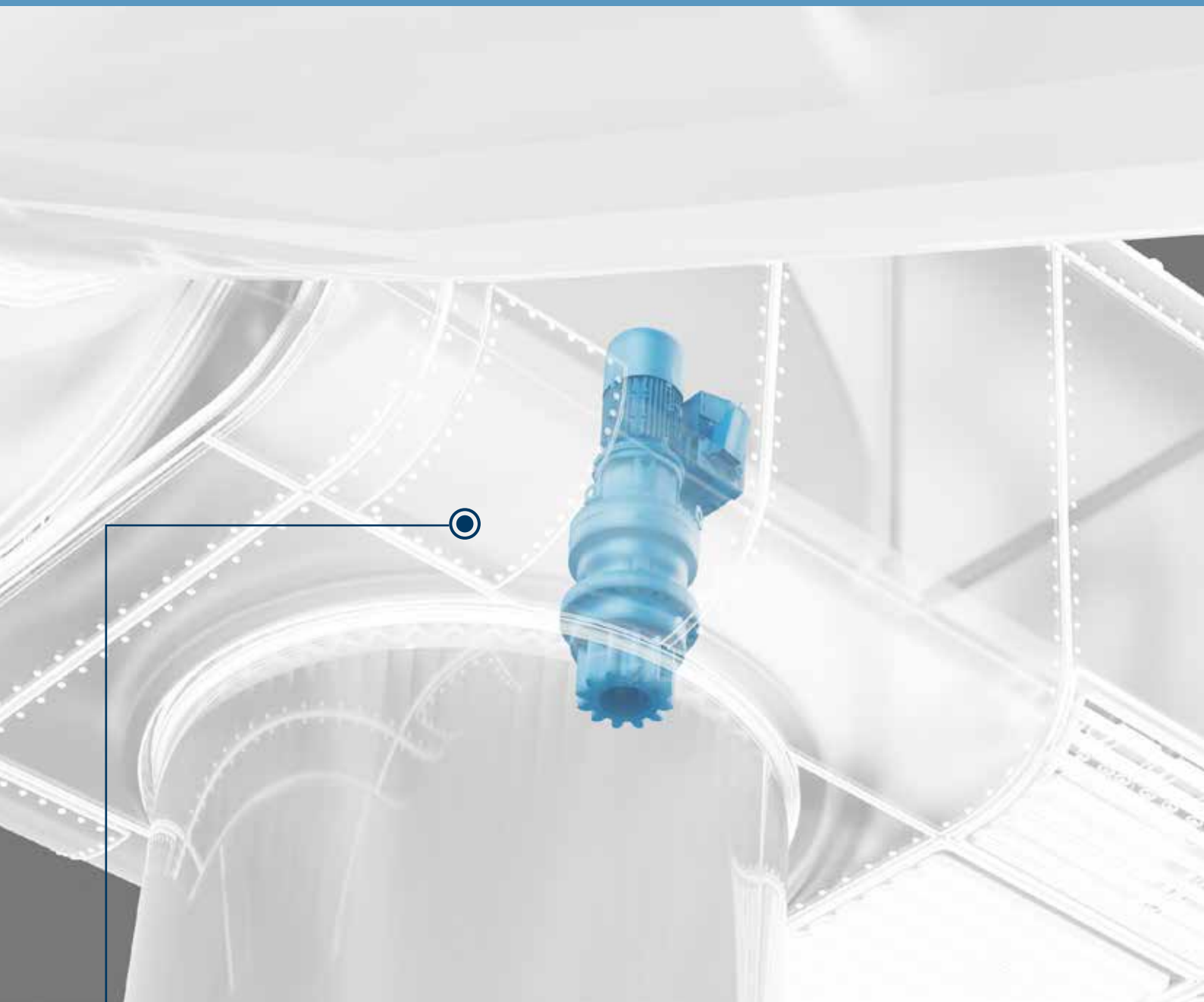

2

YAW DRIVES

WITH PERMANENT MAGNET OR ASYNCHRONOUS INDUCTION MOTORS

With a wide range of output torques and gearbox sizes, Bonfiglioli yaw drives excellently meet the OEM requirements of wind turbines. Completely custom made, this product offers a flexible solution to wind turbine manufacturers. Recent new features, like the integrated load cell and the torque limiter, show that Bonfiglioli always thinks outside the box, continuously searching for the most cost-effective solution.

- > **BN, BE & BX Series**
Asynchronous permanent magnet motor
- > **BMD Series**
Permanent magnet motors
- > **Active Cube Series**
Premium inverters
- > **AxiaVert Series**
Premium Inverters
- > **DGM Series**
Integrated Inverter

1 2

700TW SERIES
YAW & PITCH DRIVES



700TW Series

Yaw & Pitch drives

Bonfiglioli products are used in the latest state-of-the-art wind turbines to control the necessary functions of pitch and yaw drive systems. 700TW series planetary yaw and pitch drives are used by a number of leading wind turbine manufacturers due to their advanced technical features, ensuring the highest level of performance and maximum torque density. All models are certified and validated through extensive test programs.



BENEFITS

- High torque density
- Rugged construction
- High radial/thrust load capacity
- High efficiency
- Cost effective solution
- Product development according APQP4Wind

FEATURES

- Product co-engineering
- Tailor made product design

STANDARDS

- Gears are designed according to ISO 6336
- Modular design
- In line or right angle design
- Input for electric motor (IEC, NEMA)
- Flange mounted

PEAK TORQUE (Nm)

Pitch drive

706 TW	16,000
707 TW	28,000
709 TW	60,000
711 TW	80,000
712 TW	110,000
713 TW	140,000

Yaw drive

709 TW	60,000
710 TW	70,000
711 TW	90,000
712 TW	120,000
713 TW	150,000
714 TW	180,000
716 TW	225,000

The indicated data are for reference only; please contact Bonfiglioli for more detailed information.

OVERALL DIMENSIONS

Combined version
Worm gearbox - Planetary gearbox

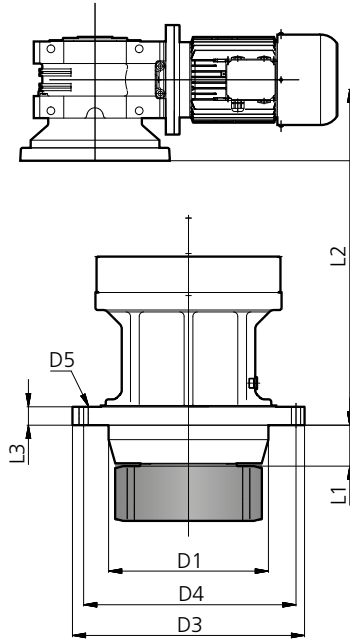

Output version **F** (short)

Inline version
Planetary gearbox

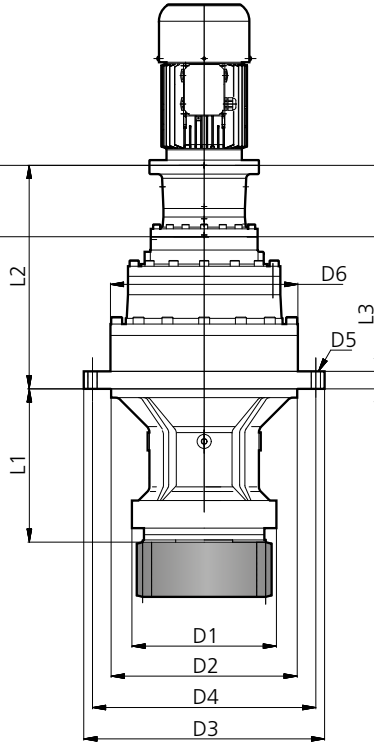

Output version **N** (long)

Right angle version
Planetary gearbox

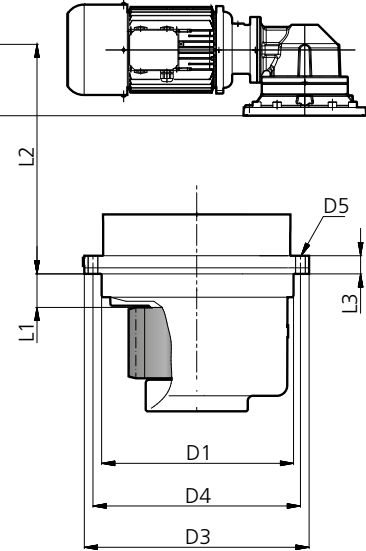

Output version **U** (pinion supported)

Type	Version	D1	D2	D3	D4	D5	D6	L1	L2	L3
706T	F	250	-	360	320	ø 18 n°24	292	130	460	35
706T	N	200	250	360	325	ø 17 n°10	292	225	350	25
707T	F	310	-	410	360	ø 22 n°12	348	70	540	30
707T	N	230	280	348	314	ø 17 n°12	348	300	360	98
709T	F	310	-	410	360	ø 22 n°12	348	70	540	30
709T	N	230	280	348	314	ø 17 n°24	348	300	400	125
709T	U	340	-	405	375	ø 17 n°24	348	90	450	40
710T	F	320	-	410	370	ø 21 n°21	400	75	600	35
710T	N	300	425	500	450	ø 22 n°12	400	360	500	40
710T	U	340	-	400	370	ø 17 n°24	400	36	550	176
711T	F	390	-	520	480	ø 17 n°30	428	60	700	35
711T	N	300	425	500	460	ø 22 n°12	428	350	520	40
712T	F	410	-	490	450	ø 21 n°24	428	125	660	40
712T	N	400	425	520	470	ø 21 n°24	428	318	580	40
712T	U	415	-	530	480	ø 26 n°16	428	140	500	45
714T	F	420	-	530	490	ø 22 n°24	490	160	870	40
714T	U	555	-	645	600	ø 30 n°32	490	97	760	100
716T	F	555	-	650	600	ø 30 n°32	542	70	900	50
716T	U	555	-	650	600	ø 30 n°32	542	70	900	50

The indicated data are for reference only; please contact Bonfiglioli for more detailed information.

PITCH DRIVE

TECHNICAL DATA

STANDARD SOLUTIONS

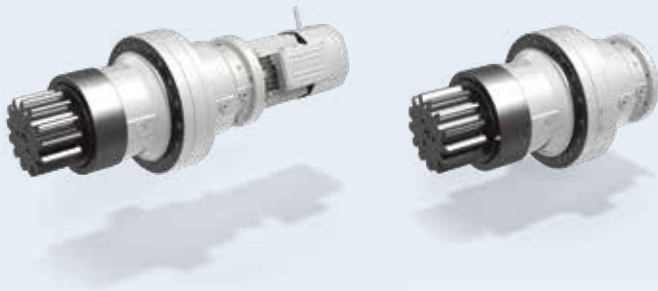

707T3N + BN132 Series
Wind turbines up to 3 MW

709T3N Series
Wind turbines up to 6 MW

INNOVATIVE SOLUTIONS



711T3F + BMD200 Series
Wind turbines up to 16 MW

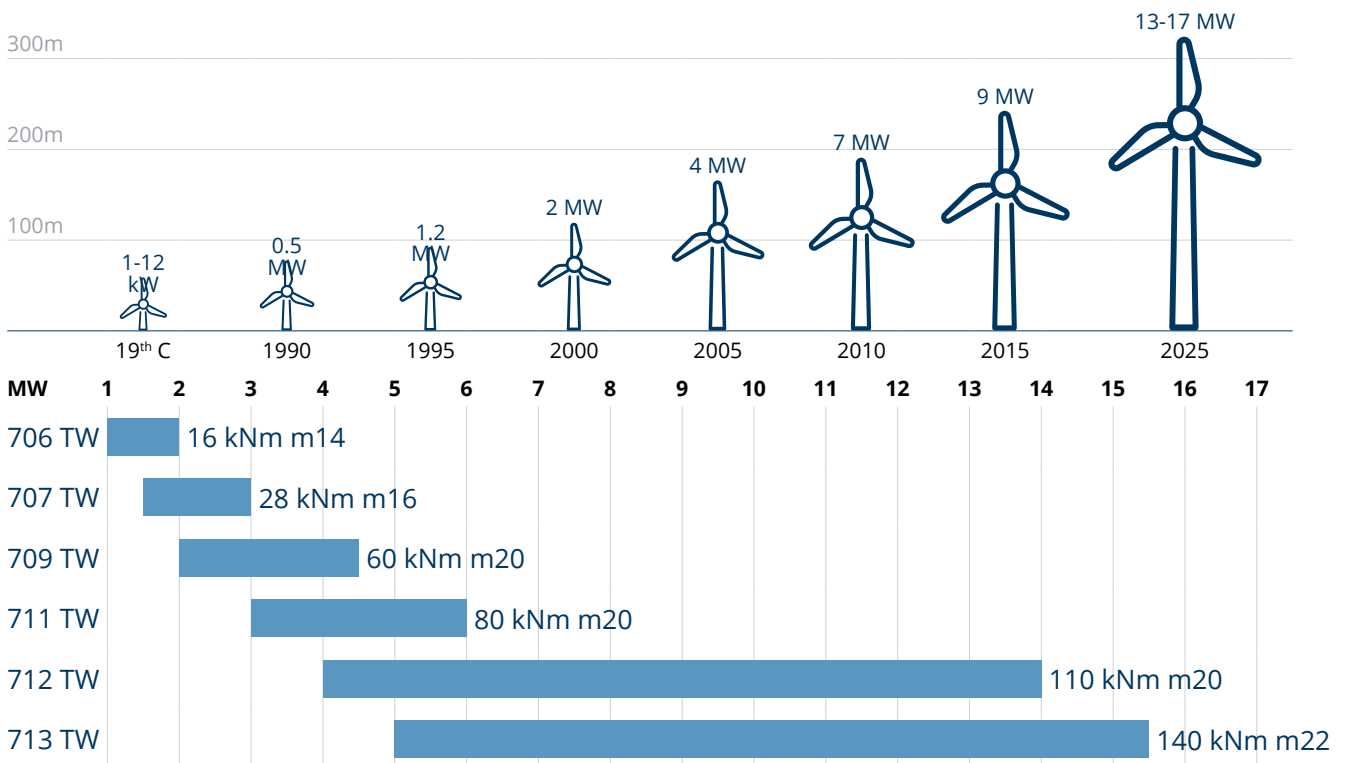

Typical application range, based on most common WTG architecture, special considerations may apply
Contact Bonfiglioli for design / selection / dimensioning of pitch system

YAW DRIVE

TECHNICAL DATA

STANDARD SOLUTIONS



709T4F Series
Wind turbines up to 8 MW



714 T4F + BN132 Series
Wind turbines up to 12 MW

INNOVATIVE SOLUTIONS



716 T4F + BE 160 + DGM inverter
Wind turbines up to 16 MW

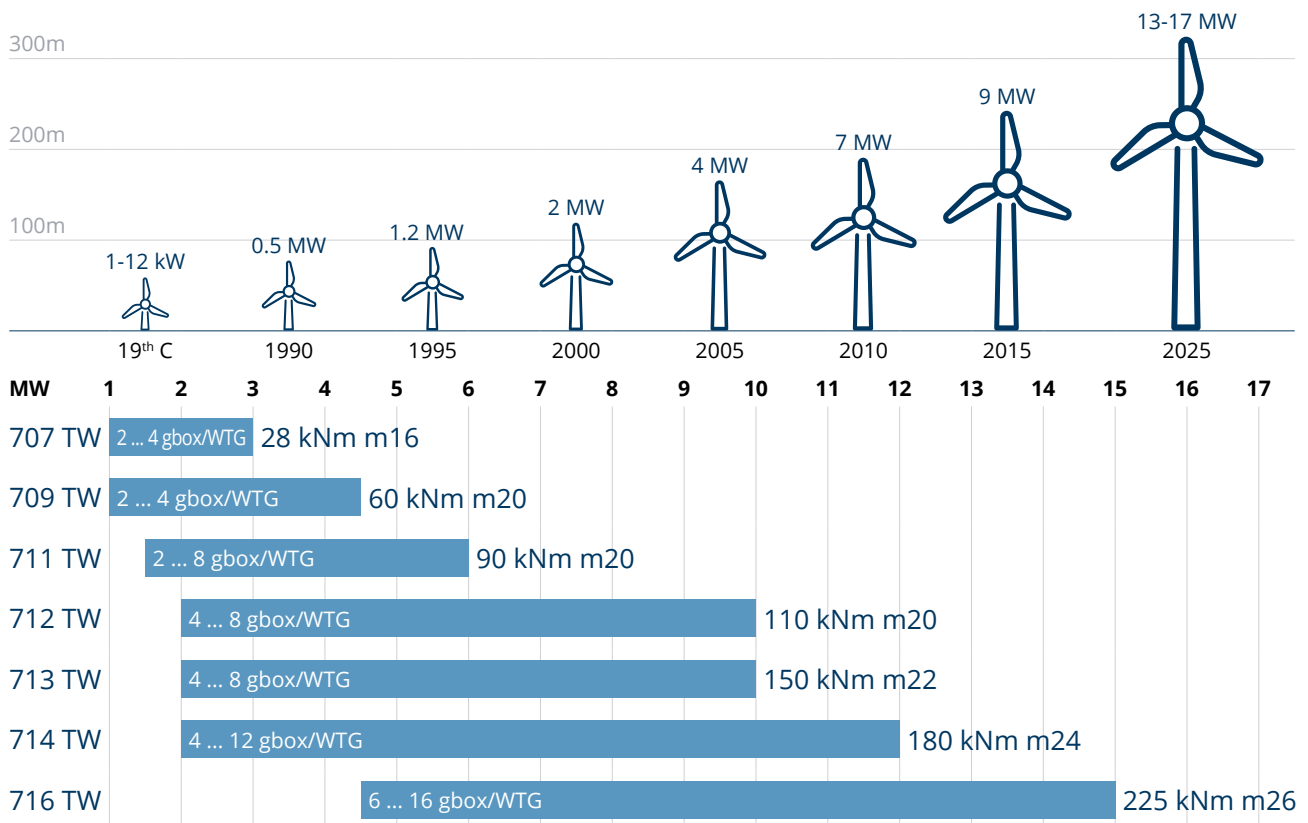

Typical application range, based on most common WTG architecture, special considerations may apply
Contact Bonfiglioli for design / selection / dimensioning of pitch system

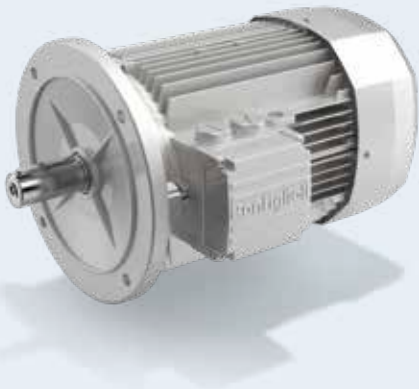

ASYNCHRONOUS IE1/IE2/IE3 THREE PHASE MOTORS

The IEC normalized induction motors have been widely used in wind applications for many years. They share the same external design for all the efficiency classes formalized by global standards, this allows customers to switch easily to higher classes when needed for local regulations.

Additionally, they comply with the most common known international certification (UL, BIS, CSA) so they can be sold worldwide.

Many options are available like EM brakes or speed sensors which increase motor performance when driven by inverter.

BN/M, BE/ME, BX/MX Series

POLES

- 2, 4, 6

TEMPERATURE SENSORS PTC

- PTC
- KTY84-130
- PT1000
- Bi-metallic

FEEDBACK

- Incremental encoder
- Absolute encoder single/multi turn
- Sin/cos absolute encoder
- Resolver

DEGREE OF PROTECTION

- Standard IP55
- Standard for brake motors IP54

POWER SUPPLY

- @50 Hz: 230/400, 280/480, 400/690
- @60 Hz: 265/460, 280/480, 330/575, 380/660

COOLING METHODS

- IC411 TENV

MOTOR OPTIONS

- Independent forced cooling
- Tropicalization
- Anti-condensate heaters
- Up to IP65 protection
- Insulation class H
- Customized connector
- Feedback predisposition

KEY BENEFITS

- Reduced operating cost
- Energy saving
- Complete solution (gearbox and motor)
- Control flexibility
- Flexibility
- Global motor

KEY FEATURES

- Compact version
- Inverter duty ready
- Multiple-speed motors
- Certified motor (UL, CSA, BIS)

EFFICIENCY CLASS

- BN > IE1
- BE > IE2
- BX > IE3

POWER (kW)

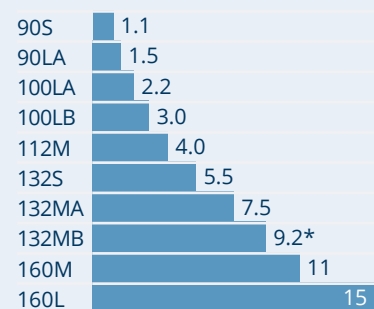

Other sizes available.

*160MA for BX

SYNCHRONOUS SERVOMOTOR

BMD servomotors are permanent magnet synchronous motors with high torque density and compact dimensions. They meet the most stringent demands for dynamics and speed & position profiles thanks to low inertia and high overload torque even at zero speed. These features, along with the multi-turn encoder or resolver the motor is equipped with, allows for very high positioning precision. The motors are optimized for operation with frequency inverters and planetary gearboxes, offering an excellent synergy.



BMD Series

POLES

- 6, 8

TEMPERATURE SENSORS PTC

- KTY84-130
- PT1000

FEEDBACK

- Resolver
- Absolute encoders

DEGREE OF PROTECTION

- Conformity Mounting options Brake types
- Standard IP55
- Standard for brake motors IP54

POWER SUPPLY

230 ... 500Vac

COOLING METHODS

- IC410 TENV
- IC416 TEFV

MOTOR OPTIONS

- Independent forced cooling
- Tropicalization
- Anti-condensate heaters
- Up to IP65 protection
- Insulation class H
- Customized connector

KEY BENEFITS

- Reduced operating cost
- Energy saving
- Complete solution (gearbox and motor)
- Control flexibility
- Flexibility
- Global motor
- High torque density
- Low rotor inertia
- High efficiency
- Torque control from zero speed

KEY FEATURES

- Compact version
- Inverter duty

EFFICIENCY CLASS

- IE4
- IE5

POWER AT 1000RPM (kW)

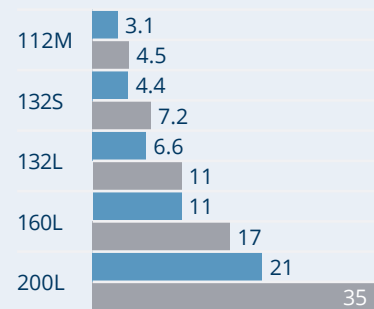

POWER AT 2000RPM (kW)

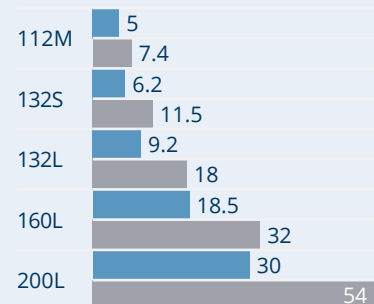

■ TENV
■ TEFV

SYNCHRONOUS RELUCTANCE MOTOR

The reluctance motor guarantees a sustainable ecological solution which decreases the total environmental impact thanks to the absence of magnets and increased efficiency. Reduced operating costs allow a fast return. This product benefits from the proven simplicity and reliability of induction motors and the higher efficiency of synchronous motors.



BSR Series

SIZES

- High efficiency package
71C ... 132 MB
- High output package
71C ... 132 MB

RATED MOTOR POWER

- High efficiency package
0.37 ... 9.2 kW
- High output package
0.55 ... 18.5 kW

POWER SUPPLY

- 400 Vac

DEGREE OF PROTECTION

- Standard IP55
- IP56 (optional)

MOTOR CUSTOMIZATIONS

- Independent forced cooling
- Tropicalization
- Anti-condensate heaters
- Up to IP65 protection
- Insulation class H
- Customized connector
- Feedback predisposition

EFFICIENCY CLASS

- BSR ... E --> IE4
- BSR ... O --> IE3 / IE4

MAIN OPTIONS

- Thermal protection
- Silicon sensor KTY 84-130
- Thermistor PTC 150
- Platinum sensor PT1000
- Forced ventilation

KEY FEATURES

- Highly accurate sensorless control technology
- Compact, economical & eco-friendly
- High dynamic response
- Energy savings
- High reliability
- High performance solution

Both Bonfiglioli packages are IES2 according to the International Efficiency of Systems (IES) classification for the drive and motor combination (IEC 61800-9-2).



PREMIUM DRIVE

The Bonfiglioli Active Cube (ACU) is a frequency inverter series offering both compactness and flexibility. This specific solution is adaptable on a wide range of applications, from high starting from high dynamic to heavy duty. The broad support for various field bus systems and the standardized interface for motion control applications make Active Cube an excellent jack of all trades for your application needs.

Active Cube Series

POWER RANGE

- 3 phase 400V mains: 0.25 - 400 kW
- 1 phase 230V mains: 0.25 - 3 kW
- 3 phase 230V mains: 0.25 – 9.2 kW

OVERLOAD CAPACITY

- up to 150 % overload for 60 s
- up to 200 % overload for 1 s

SWITCHING FREQUENCY

2, 4, 8, 12, 16 kHz

ENCLOSURE

- IP20 (EN 60529)

MOUNTING OPTIONS

- Cabinet mounting for all sizes
- Optional feed-through mounting
- Optional DIN rail mounting (size 1)
- Optional Cold-Plate (up to size 5)
- Optional liquid cooling (sizes 5 to 8)
- Vibration resilient mounting kit

MOTOR CONTROL

(open loop or optional closed loop):

- Asynchronous AC motors
- Synchronous Reluctance motors
- Permanent magnet synchronous (brushless) motors

HARDWARE FEATURES

- Integrated Safe Torque Off function (STO Sil 3 / PL e)
- DC-link connection
- Integrated brake chopper transistor
- Plug-in power terminals (up to size 2)
- Plug-in and programmable control terminals
- Standard HTL encoder Interface
- 6 digital inputs, 1 multifunction input,
- 1 digital output, 1 multifunction output,
- 1 relay output (changeover contact)
- External DC 24 V supply input
- DC 24 V / DC 10 V supply output
- Jumper to switch easily between TN mains and IT mains (up to size 6)

SOFTWARE FEATURES

- Position, Speed or Torque Control
- Table Positioning Function
- CiA402 Motion Control
- Electronic gear function
- Power failure management
- Motor supervision functions (Temperature, I2t, Software Motor switch, Encoder supervision,)
- Programmable S curve
- 4 programmable data sets
- PID controller
- Jerk-free torque/speed changeover

COMMUNICATION MODULES

- Different interface options, such as RS232, RS485, MODBUS, DeviceNet, CANopen, EtherCAT, PROFIBUS, PROFINET, Ethernet IP

EXPANSION MODULES

- Expansion of analog, digital inputs and outputs or encoder Interfaces: TTL, Resolver, SinCos, Hiperface, EnDat 2.1, EnDat 2.2, SSI

OPTIONS

- Commissioning and Diagnosis via optional keypad with copy function
- Remote Access Module with the connection interface to a PC
- Software tool VPlus for the commissioning, operation and monitoring available as Windows-PC-GUI

Accessories such as brake resistor, line chokes and EMC filters available.

HIGH PERFORMANCE FREQUENCY INVERTER

Bonfiglioli AxiaVert (AXV) series is designed to allow great flexibility and top-level performance, making it suitable for a wide range of applications. Thanks to its modular system, the AxiaVert series offers optional encoder evaluation and open communication protocols complying with industry 4.0 standards with an intuitive GU for commissioning and monitoring. For integration in functional safety environments, the AxiaVert series offers integrated Functional Safety Features, organized into different variants, which can be selected to best suit the application's requirements, optimizing price and performance to match the machine functions



AxiaVert Series

POWER RANGE

- 3 phase 400V mains: 0.25 - 15 kW
- 1 phase 230V mains: 0.25 - 3 kW
- 3 phase 230V mains: 0.25 - 9.2 kW

OVERLOAD CAPACITY

- up to 150 % overload for 60 s
- up to 200 % overload for 3 s

SWITCHING FREQUENCY

- 2, 4, 8, 12, 16 kHz

ENCLOSURE

- IP20 (EN 60529)

MOUNTING OPTIONS

- Cabinet mounting for all sizes
- Optional feed-through mounting
- Optional DIN rail mounting
- Optional Cold-Plate
- Vibration resilient mounting kit

MOTOR CONTROL

(open loop or optional closed loop):

- Asynchronous AC motors
- Synchronous Reluctance motors
- Permanent magnet synchronous (brushless) motors

HARDWARE FEATURES

- Functional Safety Modules
- Basic FS, Standard FS, Motion FS
- DC-link connection
- Integrated brake chopper transistor
- Brake control output (DC 24 V / 3 A)
- Plug-in power terminals
- Plug-in and programmable control terminals
- Standard HTL encoder Interface
- 5 digital inputs, 1 digital input/output,
- 1 multifunction input, 1 analogue output, 1 analogue input, 1 relay output (changeover contact)
- DC 24 V input (double pin connector for easy wiring)
- DC 24 V output
- Jumper to switch easily between TN mains and IT mains

SOFTWARE FEATURES

- Support for FSoE and Functional Safety encoders
- Industry 4.0 / IIoT ready
- CiA402 Motion Control
- Electronic gear function
- Power failure management
- Motor supervision functions (Temperature, I_{2t}, Software Motor switch, Encoder supervision,)
- Position, Speed or Torque Control
- Programmable S curve
- 4 programmable data sets
- PID controller
- Jerk-free torque/speed changeover

COMMUNICATION MODULES

- Different fieldbus options, such as CANopen, EtherCAT, PROFIBUS, PROFINET, Ethernet TCP/IP

EXPANSION MODULES

- Modular capability by two optional expansion modules
- Encoder Interfaces: TTL, Resolver, SinCos, Hiperface, Hiperface DSL, EnDat 2.1, EnDat 2.2, SSI

OPTIONS

- Commissioning and Diagnosis via optional graphical keypad with MMC slot and USB-C port
- Remote Access Module with the connection to a PC or a mobile phone via Bluetooth
- AxiaManager engineering software for the planning, commissioning, operation and monitoring available as Windows-PC-GUI and Mobile APP

Accessories such as brake resistor, line chokes and EMC filters available.



DECENTRALIZED INVERTER

Bonfiglioli's experience brings you DGM - the new range of decentralized inverters for asynchronous motor control. DGM is supplied with the gearmotor, for onboard assembly. The mechanical assembly, wiring and basic programming are performed by Bonfiglioli, thus reducing installation times and operations required and limiting the risk of errors to a minimum. Design and installation are faster compared to inverters installed in centralized switchboards.

DGM Series

ENCLOSURE

- IP65

OVERLOAD CAPACITY

- 150% for 60s
- 200% for 3s

CONTROL

- Sensorless Vector Control.
- PID operation with automatic speed control.
- Automatic starting torque optimization
- Configurable operation with typical quadratic curve
- Motor-potentiometer function
- Configurable quick restart

SAFETY AND PROTECTION

- STO operating safety option embedded PLC
- Motor protection I2t function
- Locked shaft control
- Start error assessment
- Motor current limitation based on the settings
- Embedded EMC filter in all versions

OPTIONS

- Brake chopper & resistors
- Closed loop control
- Fieldbus (6 different options)

PROGRAMMING

- Cover embedded MMI option
- Cover embedded Foil Keypad option
- Wide range of configuration options, also thanks to the embedded PLC

KEY BENEFITS

- Application switchboard volume and cooling system reduction
- Streamlined and simpler plant design.
- Plant extensibility not affected by switchboard capacity.
- No expensive shielded power cables required (otherwise necessary to meet the EMC standards).

KEY FEATURES

- Sensorless Vector control operation
- Configurable operation with typical quadratic curve
- Motor-potentiometer function
- PID operation with automatic speed control

POWER (kW)

DGM size A



DGM size B

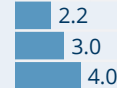

DGM size C



DGM size D

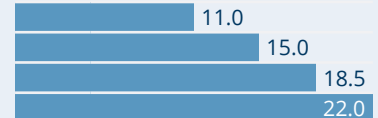

THE BONFIGLIOLI IOT PLATFORM

Today's marketplace is increasingly competitive. In this environment, complete control and visibility over your machinery is no longer an optional extra, it's a must.

ONE IOT SOLUTION FOR TWO SERVICE LEVELS

CONDITION MONITORING

Customers need to know the overall status of their equipment, including machine uptime, real-time performance, the duty cycle and energy consumption. Why? Because it drives increased uptime, eliminates unplanned failures and decreases maintenance costs. Our IoT solution delivers this via industry-standard protocols, all wrapped up in our comprehensive **Condition Monitoring** service.

PREDICTIVE MAINTENANCE

We also help boost efficiency in maintenance practices and management with our **Predictive Maintenance** service which provides you with key information, like when you need to change the oil, when gearmotors need checking and when a machine is about to break down – all before it's too late.



THE GATEWAY TO OUR IOT SOLUTIONS

Our IoT platform enables access to our **Condition Monitoring** and **Predictive Maintenance services**. Its benefits include:

- **Modular** components which can be added or removed to give a **fully customisable** solution
- A **mathematical core** based on statistical models drawing on our **deep product knowledge**
- **Carefully designed components** that meet all customer use cases
- The **flexibility** to adapt to different scenarios.

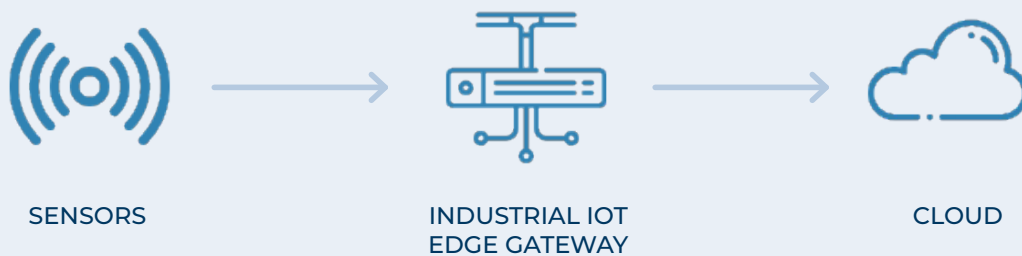

THE BONFIGLIOLI IOT PLATFORM

1. THE FUNCTIONAL PORTAL: PLACING OUR EXPERTISE AT YOUR SERVICE

The functional portal is a key element of the Bonfiglioli IoT platform, delivering significant added value through easily accessible connected services designed to deepen our relationship with you to better serve your needs.

The portal makes it simple to **monitor and report** on the operating status of components such as gearboxes – and act on warnings and alarms. It provides **insights and advice** on when to schedule RUL-based maintenance, as well as usage, uptime and performance, while its **maintenance and alerting** capabilities allow you to receive custom notifications and manage maintenance.

And for deep integration into your end users' operations, we offer a fully customisable **white label solution** for OEMs. This allows you to create a monitoring portal for all connected machines used by your customers featuring your own logo, fonts and colours.

This is further enhanced by the option for customers to use API calls to integrate IoT data into their own systems, providing them with a simple and straightforward way of benefiting from an IoT solution while retaining control of their technology.

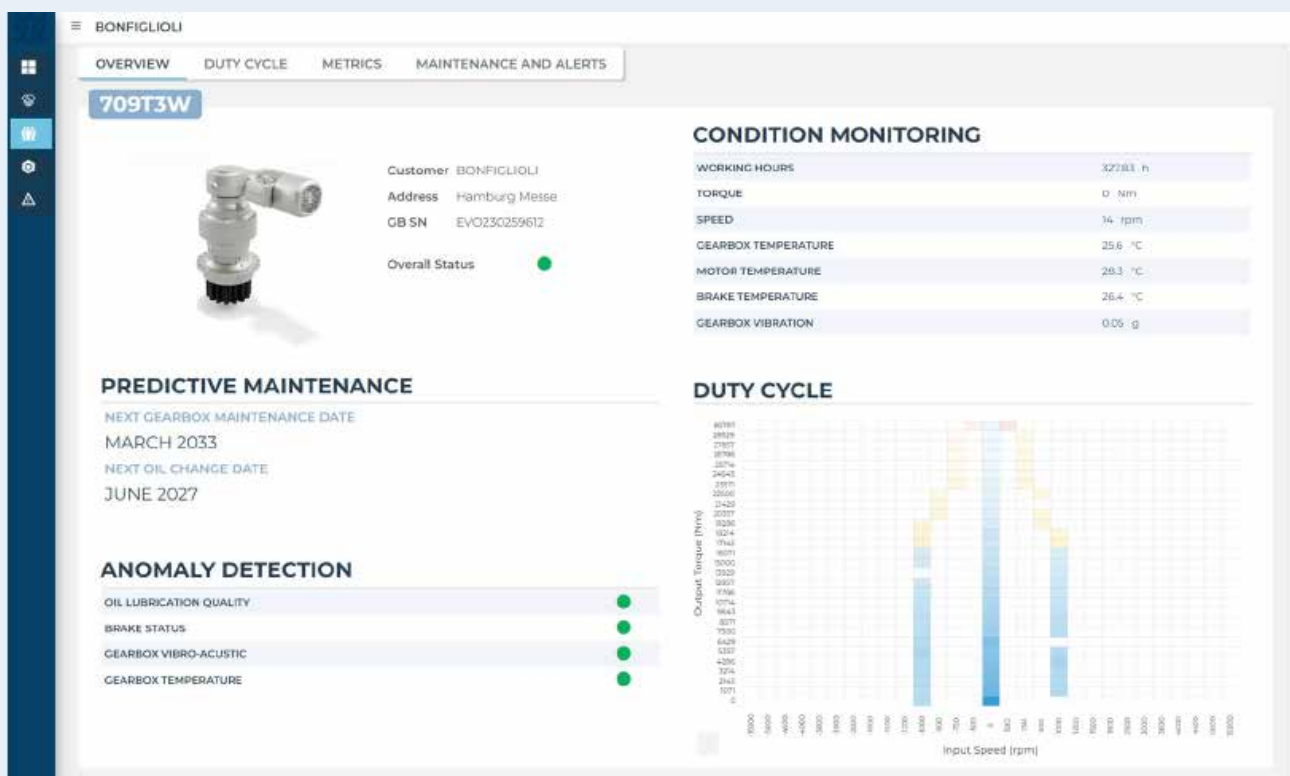

2. SENSORS: THE FOUNDATION OF OUR SOLUTIONS

Our two IoT sensors are at the core of our solutions for you. They help us deliver added value by providing the data that underpins Condition Monitoring and Predictive Maintenance.

Z-SENSOR

A small, high-performance multi-sensory device, in particular providing accelerometer, magnetometer and temperature sensor functions.

We offer two different versions of data transmission, both on RS485. The first allows high-rate data communication from embedded sensors, the second uses the Modbus RTU protocol to transmit processed data to allow immediate analysis of the acquired signals.

At just 42mm-long, heat-resistant up to 105 degrees Celsius and featuring an IP67 rating, it can be either glued onto a gearbox or inserted into the flange.

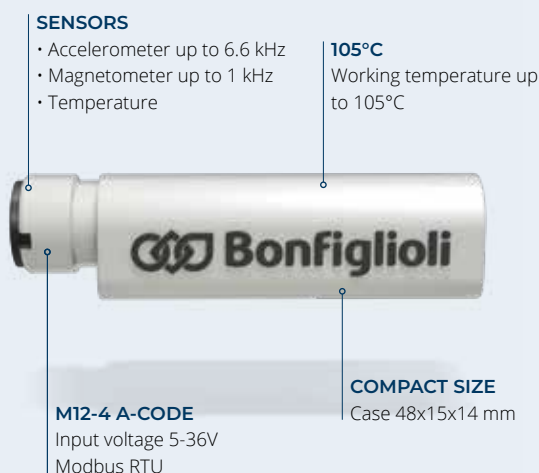

W-SENSOR

A more advanced sensor expandable to third-party sensors and measuring just 100mm x 87mm x 37mm for simple installation on gearboxes and motors. In addition to measuring and processing the same variables as the Z-Sensor, it can also collect and digitise external sensor data and uses high-resolution analogue-to-digital converters and inputs, reading and transmitting data through wireless technology using a range of standards. It also features LED lights to indicate its operational status.



OUR GOAL: LCOE REDUCTION

Bonfiglioli brings an active contributes actively to reducing LCOE. Our team of experts creates, designs and produces advanced solutions to deliver tailor-made solutions, predominantly led by a constant focus on LCOE reduction from both a direct and indirect standpoint.

HOW DO WE LOWER DIRECT COSTS?

Bonfiglioli products are cost efficient by design

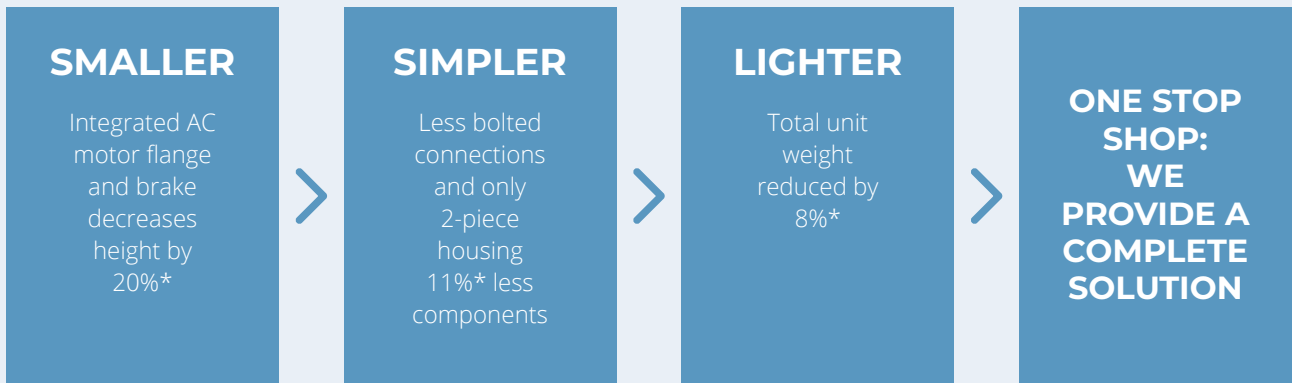

* Measures vary depending on gearbox size



HOW DO WE LOWER INDIRECT COSTS?

Indirect LCOE reduction is achieved through an evolving condition monitoring system that enables customers to maximize productivity and return on investment. Product reliability is undoubtedly an important parameter, but so is the ability to constantly check the health of the system and to plan maintenance operations. Bonfiglioli provides an IOT range that includes sensors on the gearbox and motor and an edge computer capable of conveying data and information to the customer's and/or Bonfiglioli's cloud, when a wireless connection is available.





YAW & PITCH DRIVES WITH TORQUE LIMITER

For both Yaw and Pitch drive applications, Bonfiglioli has created a torque limiter which significantly reduces downtime in the case of stopping the transmission of wind turbines when peak torque has been reached and also reduces maintenance costs.

700TW Series

RATED TORQUE RANGE

- 2,500 ... 150,000 Nm

PEAK TORQUE RANGE

- 4,500 ... 400,000 Nm

REDUCTION RATIOS

- 1:60 ... 3,000

GEARBOX CONFIGURATION

- Flange mounted
- Output shaft: with integral pinion (type: F, N, U)
- Rugged design
- High torque capacity
- Output shafts supported by high load capacity bearings

APPLICABLE AC MOTORS

- Compact motors and brake motors M/ME series
- IEC motors and brake motors BN/BE series

MAIN BRAKE MOTOR FEATURES

- DC and AC brake

MAIN BRAKE FEATURES

- AC/DC rectifier
- Double disc brake
- Microswitch
- Thermal sensors

KEY FEATURES OF TORQUE LIMITER

- External to gearbox* for fast and easy replacement - no longer necessary to replace the entire gearbox
- Limits torque peak to avoid failure
- Shuts down gearbox if torque limit is reached
- Fully interchangeable with older gearboxes - can be included in replacement drives for greater long-term reliability and reduced costs

(*) The torque limiter is located inside an easily removable and replaceable cartridge, which is integrated into a worm gear. It is only possible in a right angle solution.

The indicated data are for reference only; please contact Bonfiglioli for more detailed information.

OUR STRIVING FOR THE FUTURE



MORE THAN 250 EMPLOYEES AROUND THE WORLD ARE INVOLVED IN THE GROUP'S R&D ACTIVITIES.

DESIGN SIMULATION

Bonfiglioli has the most advanced **virtual simulation techniques** to accelerate the validation process. This reduces time to market and provides customers with optimized, efficient solutions.



TEST LABORATORIES

In our R&D department we **research, develop, validate and certify** all the products and solutions which are engineered and manufactured in our plants across the world.



CO-ENGINEERING

At Bonfiglioli we **work close to our customers to satisfy all their needs** and requirements with a truly tailor-made solution.



OUR CONSTANT AMBITION

QUALITY, HEALTH, SAFETY, ENVIRONMENT & ENERGY

QUALITY: WE CARE ABOUT OUR CUSTOMERS

Our team is completely dedicated to continuous improvement in the areas of quality, safety, environmental and energy, throughout the entire value chain, from the smallest supplier to the end client. Bonfiglioli is committed to achieving the highest quality standards, and our products are intended to generate value for our customers while respecting both people and the environment. We design, manufacture and supply effective products and services that set a benchmark for quality in the industry.

Bonfiglioli management systems are certified ISO 9001: 2015, ISO 14001: 2015, ISO 45001: 2018 and ISO 50001:2018, while our products are covered by 7 international certifications. Responsibility, excellence and continuous improvement are the basic elements that make us the favored partner of our clients and suppliers.

HEALTH & SAFETY: SUSTAINABILITY STARTS WITH SAFETY

Prevention of accidents and incidents is a key element in our company's sustainability strategy and an integral part of every one of our business processes. Successful risk management is essential for protecting our employees and assets, thereby strengthening their contributions.

ENVIRONMENT & ENERGY: RESPECT THE PRESENT TO BUILD THE FUTURE

At Bonfiglioli, we believe that respect for the present and adopting environmental protection and energy efficiency policies are essential if we are to enjoy a better future.

OUR GLOBAL PRESENCE

Thanks to an international network of closely interconnected commercial and production sites, we can guarantee the same high standards of Bonfiglioli quality anywhere at any given time. We know that our direct presence in local markets is the key to long-lasting success, so our family includes 18 production sites, 23 commercial sites and more than 550 distributors around the world.

Our organization is always close by, offering complete and efficient solutions and supporting our customers with dedicated services, co-engineering and after-sales assistance.



18

PRODUCTION SITES



23

COMMERCIAL SITES



80

COUNTRIES



550

DISTRIBUTORS



~4,700

PEOPLE

AUSTRALIA

Bonfiglioli Transmission (Aust.) Pty Ltd

2, Cox Place Glendenning NSW 2761
Locked Bag 1000 Plumpton NSW 2761
Tel. +61 2 8811 8000



BRAZIL

Bonfiglioli Redutores do Brasil Ltda

Av. Osvaldo Fregonezi, 171, cjs 31 e 44
CEP 09851-015 - São Bernardo do Campo
São Paulo
Tel. +55 11 4344 2322



CHINA

Bonfiglioli Drives (Shanghai) Co. Ltd.

#68, Hui-Lian Road, QingPu District,
201707 Shanghai
Tel. +86 21 6700 2000



Industry & Automation Solutions

#568, Longpan Road, Jiading District,
201707 Shanghai



Bonfiglioli Trading (Shanghai) Co. Ltd.

Room 423, 4th Floor, #38, Yinglun Road,
China (Shanghai) Pilot Free Trade Zone,
Shanghai



Selcom Electronics (Shanghai) Co., Ltd

A7, No.5399, Waiqingsong Road, QingPu
District,
201707 Shanghai
Tel. +86 21 6010 8100



A24, No.5399, Waiqingsong Road, QingPu

District,
201707 Shanghai
Tel. +86 21 6010 8100



FRANCE

Bonfiglioli Transmission S.A.S.

14 Rue Eugène Pottier
Zone Industrielle de Moimont II
95670 Marly la Ville
Tel. +33 1 34474510



GERMANY

Bonfiglioli Deutschland GmbH

Sperberweg 12 - 41468 Neuss
Tel. +49 0 2131 2988 0



Bonfiglioli Vectron GmbH

Europark Fichtenhain B6 - 47807 Krefeld
Tel. +49 0 2151 8396 0



O&K Antriebstechnik GmbH

Ruhrallee 8-12 - 45525 Hattingen
Tel. +49 0 2324 2050 1



INDIA

Bonfiglioli Transmission Pvt. Ltd.

Mobility & Wind Industries

AC 7 - 11, SIDCO Industrial Estate,
Thirumudivakkam
Kancheepuram - 600132 - Tamil Nadu
Tel. +91 844 844 8649



Industry & Automation Solutions

Survey No. 528/1, Perambakkam High Road
Mannur Village, Sriperumbudur Taluk
Kancheepuram - 602 105 - Tamil Nadu
Tel. +91 844 844 8649



Industry & Automation Solutions

Plot No E-5/2, Badhalwadi
Talegaon MIDC Phase II,
Pune - 410 507 - Maharashtra
Tel. +91 844 844 8649



Bonfiglioli Drive Systems Pvt. Ltd.

Industry & Automation Solutions

No 50, Pappambakkam Road,
Mannur Village, Sriperumbudur Taluk,
Kancheepuram - 602105 - Tamil Nadu
Tel. +91 844 844 8649



ITALY

Bonfiglioli Riduttori S.p.A.

Industry & Automation Solutions

Via Cav. Clementino Bonfiglioli, 1
40012 Calderara di Reno
Tel. +39 051 6473111



Industry & Automation Solutions

Via Sandro Pertini, lotto 7b
20080 Carpiano
Tel. +39 02985081



Industry & Automation Solutions

Via Saliceto, 15 - 40010 Bentivoglio



Mobility & Wind Industries

Via Enrico Mattei, 12 Z.I. Villa Selva
47122 Forlì
Tel. +39 0543 789111



Industry & Automation Solutions

Via Unione, 49 - 38068 Rovereto
Tel. +39 0464 443435/36



Selcom Group S.p.A.

Via Achille Grandi, 5
40013 Castel Maggiore (BO)
Tel. +39 051 6387111



Via Marino Serenari, 18
40013 Castel Maggiore (BO)
Tel. +39 051 6387111



Via Cadriano, 19
40057 Cadriano (BO)
Tel. +39 051 6387111

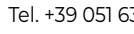

NEW ZEALAND

Bonfiglioli Transmission (Aust.) Pty Ltd

88 Hastie Avenue, Mangere Bridge,
2022 Auckland
PO Box 11795, Ellerslie
Tel. +64 09 634 6441



SINGAPORE

Bonfiglioli South East Asia Pte Ltd

8 Boon Lay Way, #04-09,
8@Tadehub 21, Singapore 609964
Tel. +65 6268 9869



SLOVAKIA

Bonfiglioli Slovakia s.r.o.

Robotnícka 2129
Považská Bystrica, 01701 Slovakia
Tel. +421 42 430 75 64



SOUTH AFRICA

Bonfiglioli South Africa Pty Ltd.

55 Galaxy Avenue, Linbro Business Park,
Sandton, Johannesburg
2090 South Africa
Tel. +27 11 608 2030



SPAIN

Tecnotrans Bonfiglioli S.A

Avinguda del Ferrocarril, n° 14,
Polígono Industrial Can Estapé
08755 Castellbisbal - Barcelona
Tel. +34 93 447 84 00



TURKEY

Bonfiglioli Turkey Jsc

Atatürk Organize Sanayi Bölgesi,
10007 Sk. No. 30
Atatürk Organize Sanayi Bölgesi,
35620 Çiğli - İzmir
Tel. +90 0 232 328 22 77



UNITED KINGDOM

Bonfiglioli UK Ltd.

Unit 1 Calver Quay, Calver Road, Winwick
Warrington, Cheshire - WA2 8UD
Tel. +44 1925 852667



USA

Bonfiglioli USA Inc.

3541 Hargrave Drive
Hebron, Kentucky 41048
Tel. +1 859 334 3333



VIETNAM

Bonfiglioli Vietnam Ltd.

Lot C-9D-CN My Phuoc Industrial Park 3
Ben Cat - Binh Duong Province
Tel. +84 650 3577411





We have a relentless commitment to excellence, innovation & sustainability. Our team creates, distributes and services world-class power transmission & drive solutions to keep the world in motion.

HEADQUARTERS

Bonfiglioli S.p.A

Via Cav. Clementino Bonfiglioli, 1
40012 Calderara di Reno - Bologna (Italy)
Tel. +39 051 6473111

