

Sealing Structure

To prevent grease leakage and maintain high durability of reducer, the following sealing structure must be used.

1. Rotating motion: oil seal (spring embedded), please check if scratches on shaft side.
2. Flange mounting surface: O-ring, sealant. Please pay attention to whether any skewed or engagement of O-ring. (Below table for O-ring/slot size)
3. Screw hole: use screw with sealing or sealing tape.

Necessary seal locations		Recommend sealing method
The output side	The through-hole in the center of the output flange and the assembly surface of the output flange	Use O-ring (attached to our products)
	Mounting screw	Screw with sealing effect
The Input side	Flange mounting surface	Use O-ring (attached to our products)
	Motor output shaft	If there is no oil seal, install the oil seal on the installation flange of the motor

Reducer installation seal O-ring/groove size table

Product model	Flex Spline side				Circular Spline side			
	O-RING	O-GROOVE			O-RING	O-GROOVE		
		∅D1	∅D2	L1		∅D3	∅D4	L2
WHSG-14-II	55*1.2	53.3	56.5	0.89	37.5*0.6	36.5	38.1	0.45
WHSG-17-II	65.5*1.5	64.1	68.1	1.1	45.5*0.65	45	47	0.45
WHSG-20-II	74.5*2	72.6	78	1.5	52.2*0.8	52.6	54.6	0.6
WHSG-25-II	91.7*1.8	90	94.8	1.35	66*1.2	66	69	0.9
WHSG-32-II	119.5*2	117.6	123	1.5	86*1.5	86	90	1.1

Reducer installation seal O-ring/groove size table

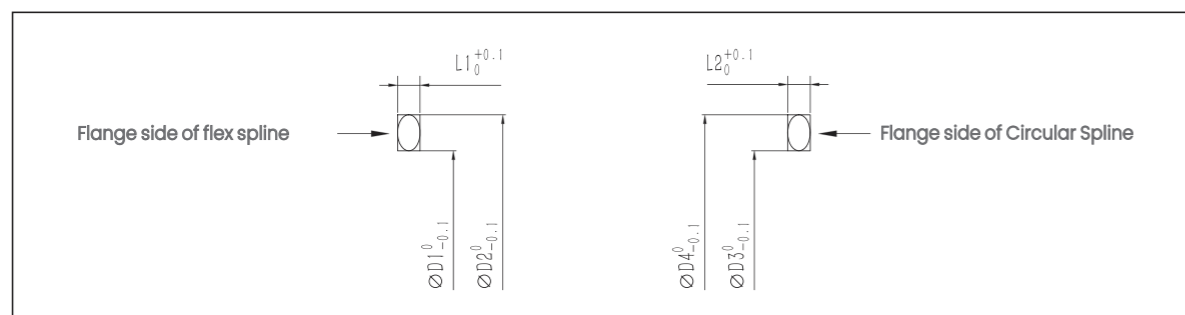

Assembly Precautions

Improper assembly may cause vibrate, abnormal sound, etc. problem, so please follow the following assembly precautions:

1. Attentions to wave generator

- (1) please avoid applying excessive force to the bearing part of the wave generator during assembly. The insertion can be carried out smoothly by rotating the wave generator.
- (2) when using a integrated wave generator, please pay special attention to control the center deviation and the influence of skew within the recommended value.

2. Attentions to circular spline

- (1) Check if the flatness of the installation surface is good and if there is any skew.
- (2) Check if the hole part of the screw is uplifted, with residual burr or foreign body.
- (3) Check if chamfering and avoidance processing have been carried out on the assembly part of the shell to avoid interference with the circular spline.
- (4) when the steel wheel is assembled to the shell, check if it can rotate and whether there is interference and clamping.
- (5) when inserting the bolt toward the bolt hole for installation, check if the bolt hole is in the correct position, whether the bolt is in contact with the circular spline due to the skew machining of the bolt hole and other reasons, so that the bolt rotation becomes heavy.
- (6) please do not tighten the bolts according to the specified torque at one time. Please tighten them temporarily with a force of about 1/2 of the specified torque before tightening them according to the specified torque.
- (7) Pin to the circular spline may cause low rotation accuracy, so please avoid it as much as possible.

3. Attention to flex spline

- (1) Check if the flatness of the installation surface is good and whether there is any skew.
- (2) Check if the hole part of the screw is uplifted, with residual burr or foreign body.
- (3) Check if chamfering and avoidance processing have been carried out on the assembly part of the shell to avoid interference with the flex spline.
- (4) when inserting the bolt toward the bolt hole for installation, confirm whether the bolt hole is in the correct position, whether the bolt is in contact with the flex spline due to the skew machining of the bolt hole and other reasons, so that the bolt rotation becomes heavy.
- (5) please do not tighten the bolts according to the specified torque at one time. Please tighten them temporarily with a force of about 1/2 of the specified torque before tightening them according to the specified torque.
- (6) Check if there is extreme unilateral engagement when it is in conjunction with the circular spline group. When unilateral migration occurs, it may be due to center deviation or skew of two parts.
- (7) when assembling the flex spline, please do not tap the gear front of the opening part or press with excessive force.

4. Other attentions:

- (1) The reducer must be installed in a sufficiently clean environment, and no foreign matter shall enter the reducer during installation to avoid damage during use.
- (2) Please ensure that the gear surface and flexible bearing of the reducer are always fully lubricated. It is not recommended to use the tooth face up all the time, which will affect the lubrication effect.
- (3) After installing the wave generator, please check the engagement between the flex spline and circular spline is 180° symmetrical (FIG. 1). For example, deviation to the side (FIG. 2) will cause abnormal vibration and quickly damage the flexible wheel.
- (4) After the installation is completed, please run at a low speed (100rpm). If there is abnormal vibration or abnormal sound, please stop immediately, and re-check whether the installation is correct or contact our company, so as to avoid damage to the reducer caused by improper installation.

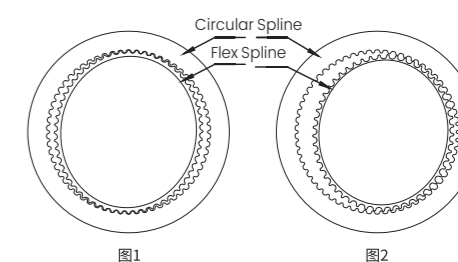

Assembly Method

1.WCSG Installation (circular spline fixed, flex spline output)

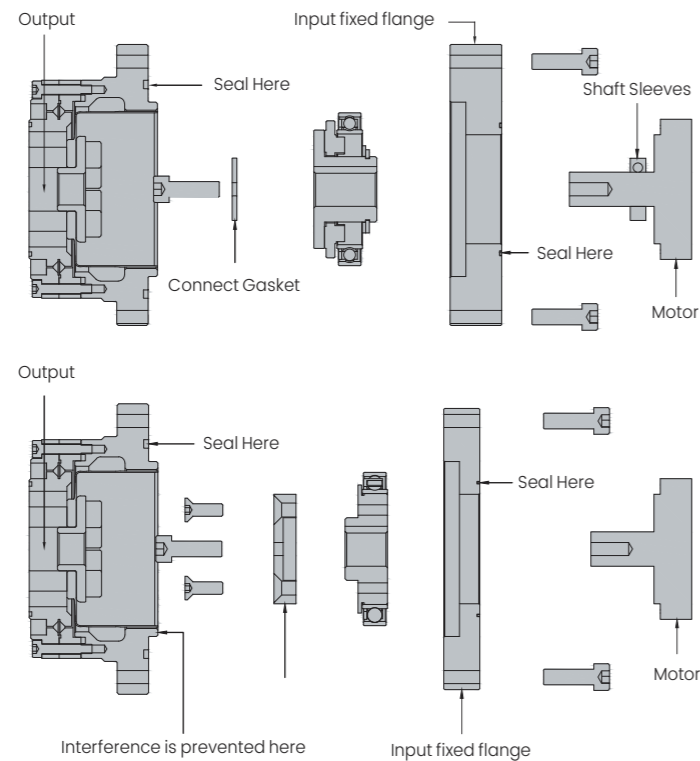

1. Apply the grease evenly on the flexible bearing, and fill the cavity connected with the fixed flange and the motor with the grease (please use the specified grease, do not replace the grease randomly to avoid damage to the reducer). Install the wave generator on the motor shaft or connecting shaft of the input end, and fix it with screw and flat gasket or connecting end cover.

2. Apply the grease evenly on the flexible spine, and fill flex spline with the grease. The injection volume is approximately 80% of the cavity volume (please use the specified grease, do not replace the grease randomly to avoid damage to the reducer). Install the reducer according to the diagram. When installing, the long axis of the wave generator is aligned to the direction of the long axis of the reducer's flex spline. When in place, the reducer is fixed with the corresponding screw. The pre-tightening force of the screw is 0.5Nm.

3. Set the motor speed at about 100 rotations per minute, start the motor, and the screws shall be locked by means of crisscross for four to five times to increase the locking force of the screws equally. (for screw locking force, see page 96) all fixed screws shall be of grade 12.9 and shall be coated with Loctite 243 thread adhesive to prevent screw failure or loose during operation.

4. processing requirement for mounting surface that connected with reducer: flatness 0.01mm, vertical axis 0.01mm.

Note:

When the reducer is in use, if the output end is always horizontally facing down (it is not recommended to use in this way), please contact us if the lubricating oil injected into the inner wall of the flex spline exceeds the meshing tooth surface. Please use the specified lubricating grease, do not change the grease at will to avoid damage to the reducer. Static sealing shall be adopted between the circular spline of reducer and the installation plane of input end to ensure the grease will not leak during the use of reducer and avoid the damage of reducer when it works with little or no oil.

2.WSHG-I/II Installation (1) (circular spline fixed, flex spline output)

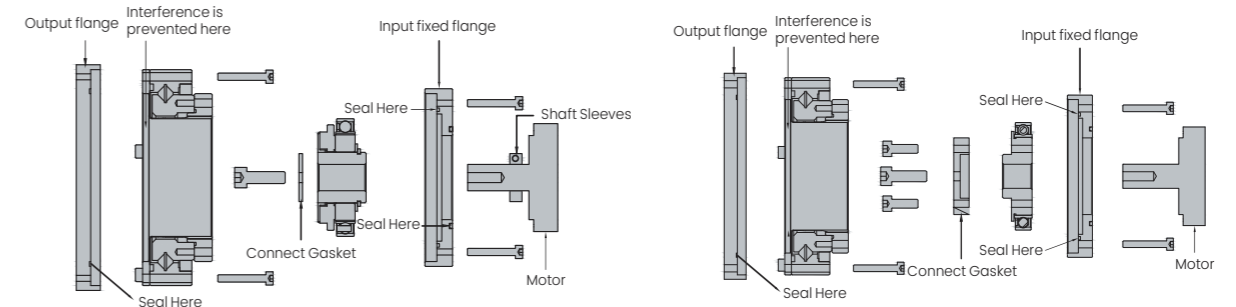

1. Apply the grease evenly on the flexible bearing, and fill the cavity connected with the fixed flange and the motor with the grease (please use the specified grease, do not replace the grease randomly to avoid damage to the reducer). Install the wave generator on the motor shaft or connecting shaft of the input end, and fix it with screw and flat gasket or connecting end cover.

2. Install the reducer according to the diagram. When installing, the long axis of the wave generator is aligned to the direction of the long axis of the reducer's flex spline. When in place, the reducer is fixed with the corresponding screw. The pre-tightening force of the screw is 0.5Nm.

3. Set the motor speed at about 100 rotations per minute, start the motor, and the screws shall be locked by means of crisscross for four to five times to increase the locking force of the screws equally. (for screw locking force, see page 96) all fixed screws shall be of grade 12.9 and shall be coated with Loctite 243 thread adhesive to prevent screw failure or loose during operation.

4. Apply a layer of grease evenly on the inner wall of the flexible pulley, and then inject the grease into the cavity of the flexible pulley. The injection amount is about 80% of the cavity of the flexible pulley.

5. The output end is also fixed according to step 3. All fixed screws shall be grade 12.9 and coated with Loctite 243 thread adhesive to prevent screw failure or loose during operation.

6. Machining requirements for installation plane fixed with reducer: plane degree 0.01mm, and axis perpendicular 0.01mm

Note:

When the reducer is in use, if the output end is always horizontally facing down (it is not recommended to use in this way), please contact us if the lubricating oil injected into the inner wall of the flex spline exceeds the meshing tooth surface. Please use the specified lubricating grease, do not change the grease at will to avoid damage to the reducer. Static sealing shall be adopted between the circular spline of reducer and the installation plane of input end to ensure the grease will not leak during the use of reducer and avoid the damage of reducer when it works with little or no oil.

3.WSHG-I/II Installation (2) (Flex spline fixed, circular spline output)

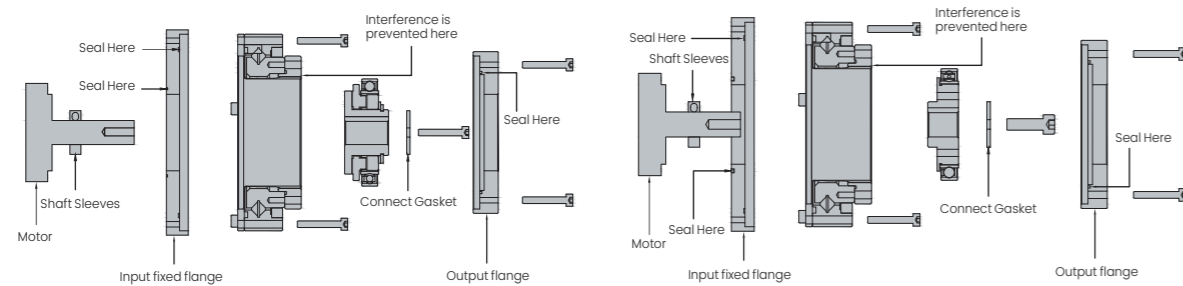

- 1.The reducer is installed at the input end and fixed with the corresponding screw. The screw pretightening force is 0.5Nm.
- 2.First, evenly apply a layer of grease on the inner wall of the flex spline, and then inject grease at the space B of the flex spline with an injection amount of about 80% of the cavity of the flex spline (please use the specified lubricating grease, and do not replace the grease at will to avoid damage to the reducer).
- 3.Install the reducer according to the diagram. When installing, the wave generator long axis aligned with the long axis of the flex spline, after installing in place, turn the wave generator, make the key on the CAM and the key on the input shaft alignment, install the key (key coated with Loctite 638 glue), with a screw plus large gasket to fix the wave generator on the shaft.
- 4.Apply grease uniformly on the flexible bearing and fill the cavity of A with grease (please use the specified lubricating grease and do not change grease at will to avoid damage to the reducer)
- 5.Set the motor speed at about 100 RPM, start the motor, and tighten the screws crossingly for four to five times with equal increase to the locking force corresponding to the screw. (The locking force for screws is shown on page 96.) All screws to be fastened shall be of grade 12.9 and coated with Loctite 243 thread adhesive to prevent failure or loose working
- 6.The output end is also fixed according to step 5.All fixing screws shall be of grade 12.9 and coated with Loctite 243 thread adhesive to prevent screw failure or loosening during operation.
- 7.Machining requirements for installation plane fixed with reducer: plane degree 0.01mm, and axis perpendicular 0.01mm.

Note:

When the reducer is in use, if the output end is always horizontally facing down (it is not recommended to use in this way), please contact us if the lubricating oil injected into the inner wall of the flex spline exceeds the meshing tooth surface. Please use the specified lubricating grease, do not change the grease at will to avoid damage to the reducer. Static sealing shall be adopted between the circular spline of reducer and the installation plane of input end to ensure the grease will not leak during the use of reducer and avoid the damage of reducer when it works with little or no oil.

4.WSHG-III Installation (3) (4) (Flex spline fixed, circular spline output)

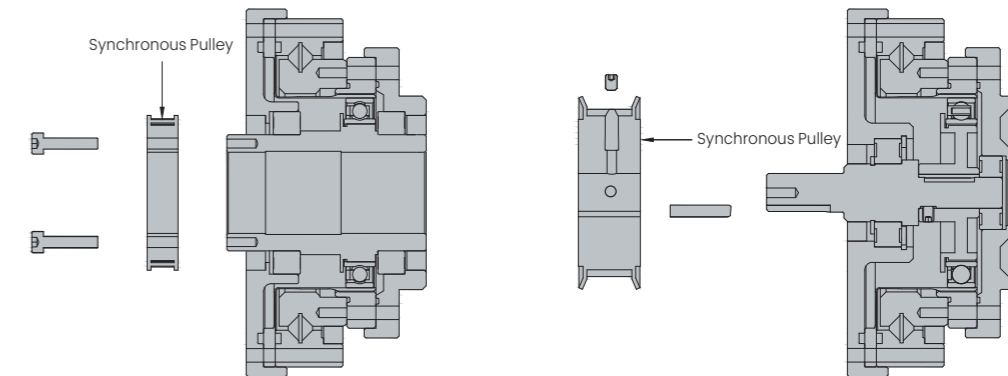

The reducer mount way when the motor shaft is smooth shaft

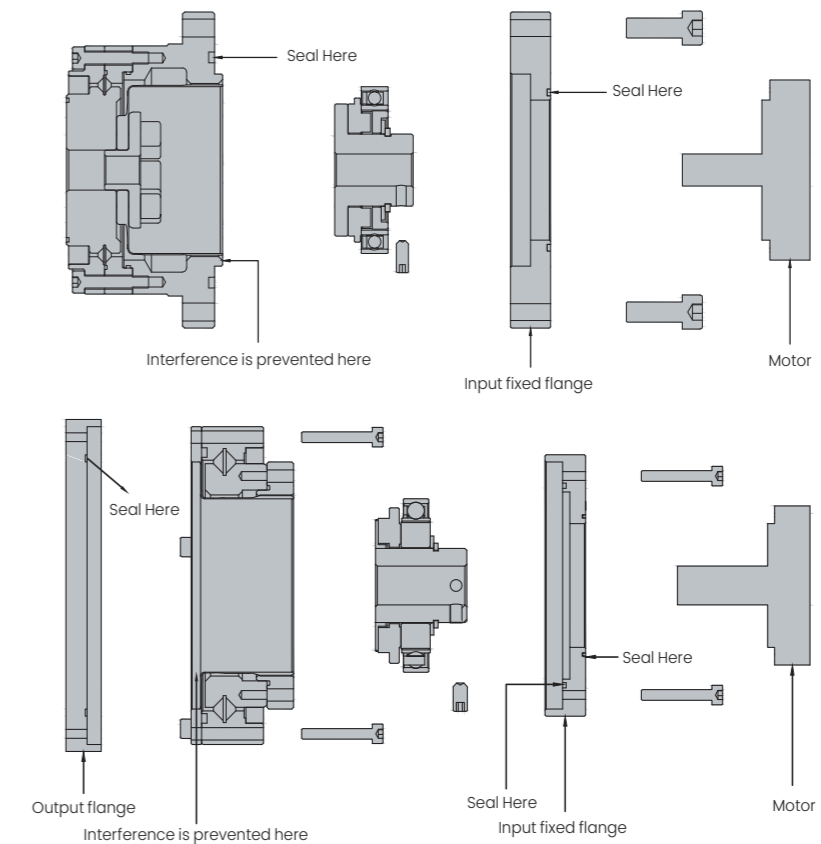

Screw locking method

1.Set motor speed at 100 rpm, and start motor. The screws are locked in crisscross manner. Try 4 to 5 times increased by degrees until it reaches corresponding locking force (see chart below).

2.Mounting plane processing requirements prescribed by connecting reducer: flatness 0.01mm, Screw locking method.

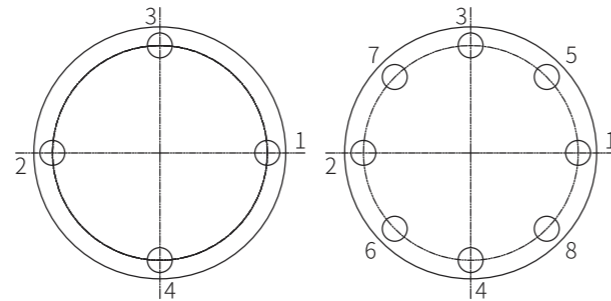

Screws correspond to locking force

		12.9						
Screw Nominal Diameter	mm	3	4	5	6	8	10	12
Locking Torque	N·m	2	4	9	15	35	70	125

Installation accuracy of reducer

I.Motor installation

Flange for motor installation: when the motor is installed on the combined type, the motor installation flange must be used for installation. The civil construction size and schedule of the flange base components for motor installation are shown in the following figure and table.

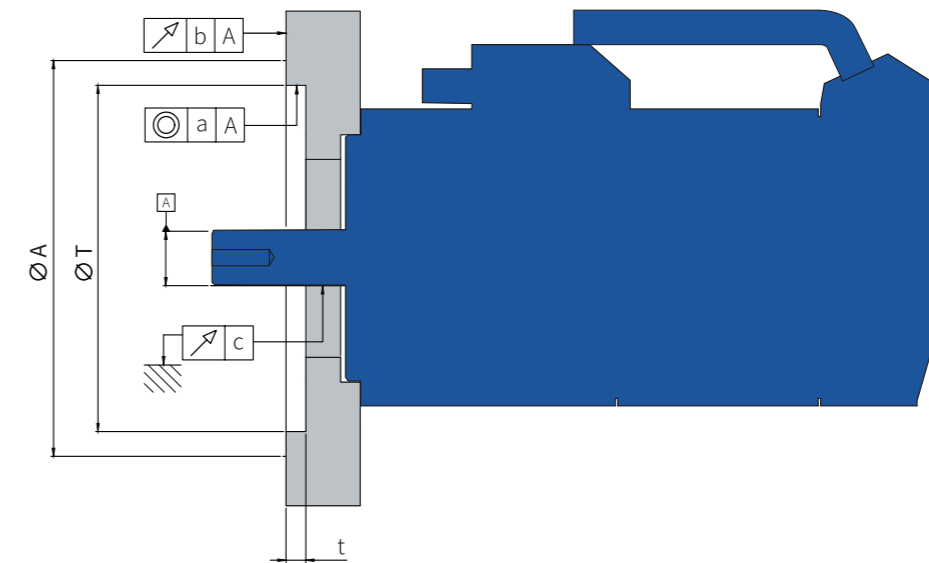

Unit:mm

Model Symbol	14	17	20	25	32
a	0.03	0.04	0.04	0.04	0.04
b	0.03	0.04	0.04	0.04	0.04
c	0.015	0.015	0.018	0.018	0.018
ØA	73	79	93	107	138
t	3	3	4.5	4.5	4.5
ØT	38H7	48H7	56H7	67H7	90H7

2.WCSG (F) - II Series assembly precision

Flange for motor installation: when installing the motor to the combined type, the motor mounting flange must be used for installation. Please refer to the following table and figure for mounting dimensions and precision of flange base components for motor installation.

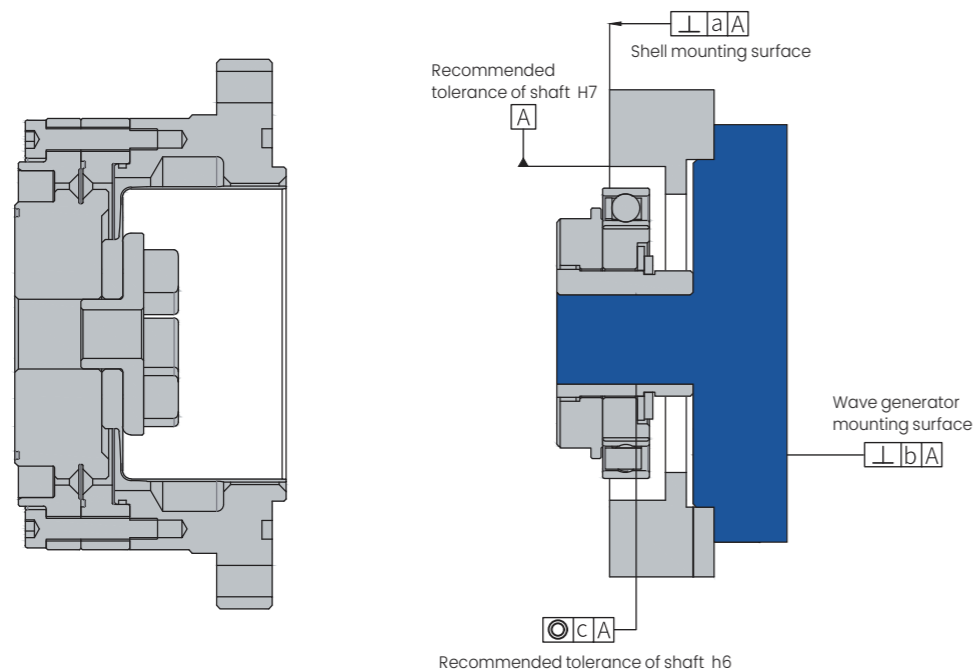

Unit:mm

Model Symbol	14	17	20	25	32
a	0.011	0.015	0.017	0.024	0.026
b	0.017	0.020	0.020	0.024	0.024
	(0.008)	(0.010)	(0.010)	(0.012)	(0.012)
c	0.030	0.034	0.044	0.047	0.050
	(0.016)	(0.018)	(0.019)	(0.022)	(0.022)

The values in () are those when the input unit (wave generator) is integrated structure.
(When European coupling structure is not used)

WCSD- I Series assembly precision

During assembly design, if there are abnormalities such as deformation of the mounting surface, or reluctant assembly, the product performance will be reduced. In order to give full play to the excellent performance of reducer, please pay attention to the following points and ensure to use the recommended precision of the assembled casing shown in the following picture and table.

- 1.The mounting surface is skewed and deformed
- 2.Foreign matter engaged-in
- 3.Burrs, bulges, and abnormal positions around the screw holes of the mounting holes
- 4.Insufficient chamfering of mounting concave round part
- 5.The roundness of the mounting concave round part is abnormal

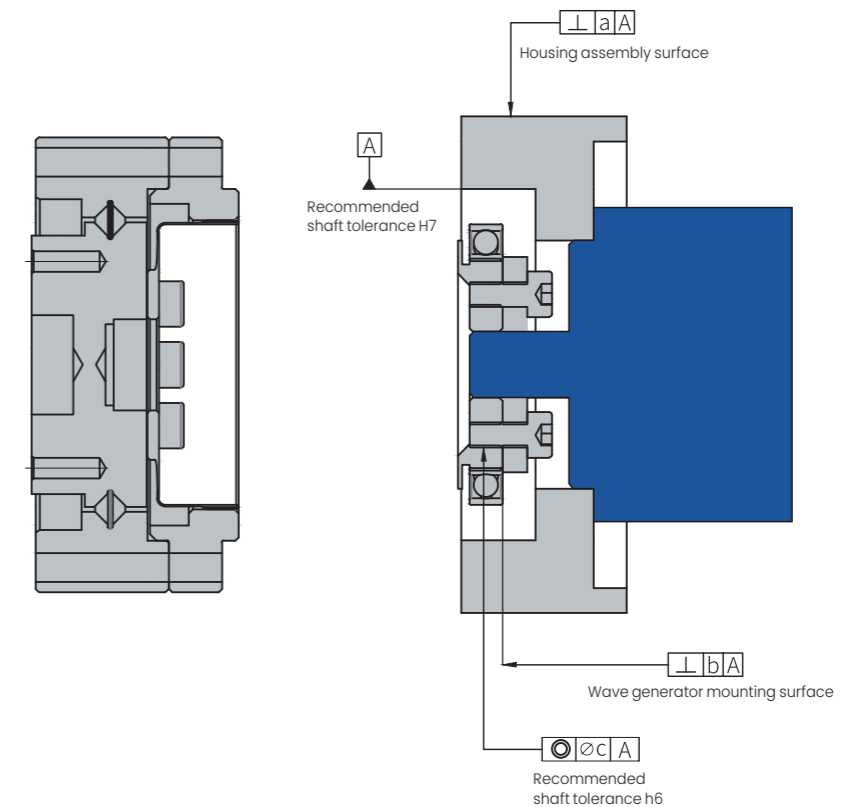

Unit:mm

Model Symbol	14	17	20	25	32
a	0.011	0.015	0.017	0.024	0.026
b	0.008	0.010	0.012	0.012	0.012
øc	0.016	0.018	0.019	0.022	0.022

WSHG(F) -II series assembly precision

During assembly design, to insure that harmonic reducer in use with optimal performance, please insure that using the recommend precision of assemble housing as shown below. (see chart below).

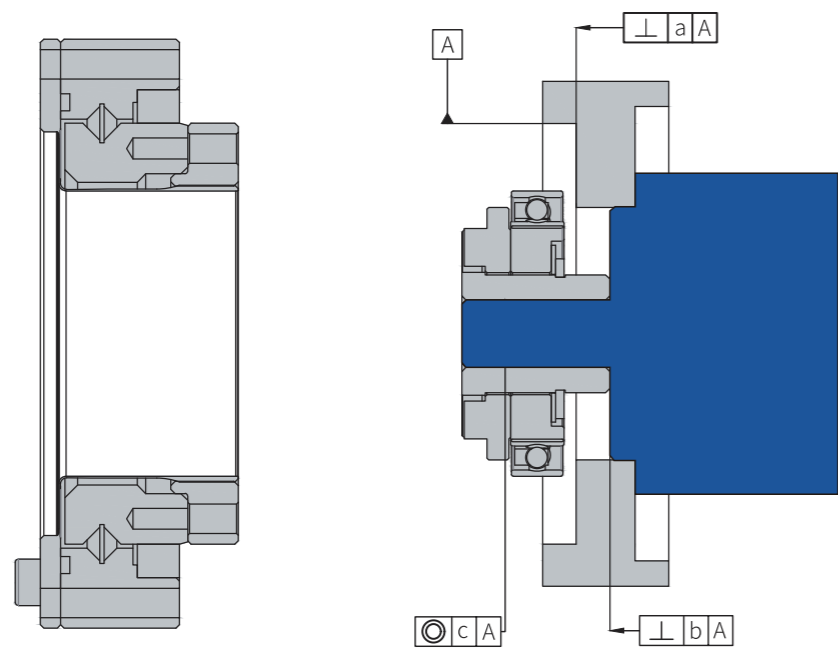

Unit:mm

Model Symbol	14	17	20	25	32
a	0.011	0.015	0.017	0.024	0.026
b	0.017	0.020	0.020	0.024	0.024
	(0.008)	(0.010)	(0.010)	(0.012)	(0.012)
c	0.030	0.034	0.044	0.047	0.050
	(0.016)	(0.018)	(0.019)	(0.022)	(0.022)

Value in () is the numerical values when input unit(wave generator) is one-piece structure (unused European coupling structure)

WSHD-I(II) series assembly precision

During assembly design, product performance will be reduced if there is abnormal situation, such as deformation of mounting surface. Assembled reluctantly will decrease product performance as well.

To insure that harmonic reducer in use with optimal performance, please pay attention to the following points, and insure that using the recommend precision of assemble housing as shown below. (see chart below).

- 1.Deflection and distortion about assembled surface
- 2.Foreign body embedding
- 3.Screw hole of mounting hole appears burr around, bulge, and abnormal position
- 4.The chamfering concave part is insufficient
- 5.The roundness of installation concave part is abnormal

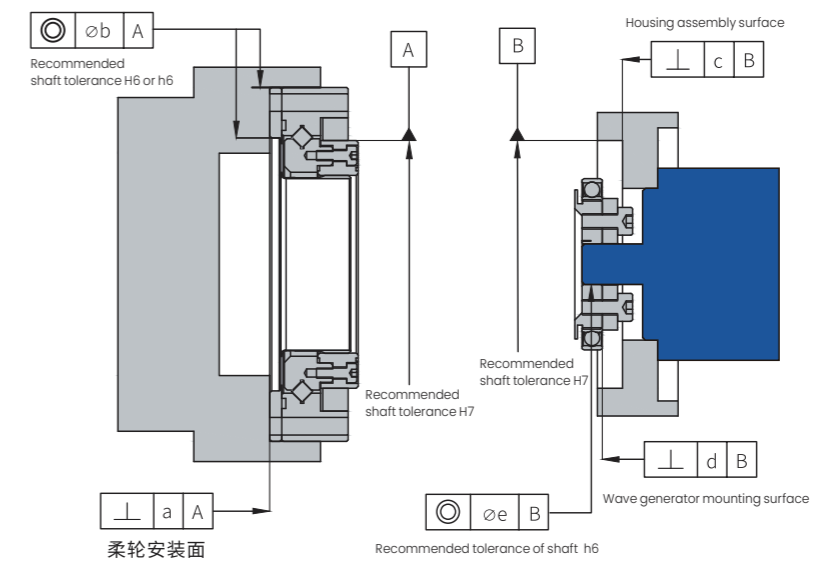

Unit:mm

Model Symbol	14	17	20	25	32
a	0.016	0.021	0.027	0.035	0.042
øb	0.015	0.018	0.019	0.022	0.022
c	0.011	0.012	0.013	0.014	0.016
d	0.008	0.010	0.012	0.012	0.012
øe	0.016	0.018	0.019	0.022	0.022

Application area



Robots



Armarium

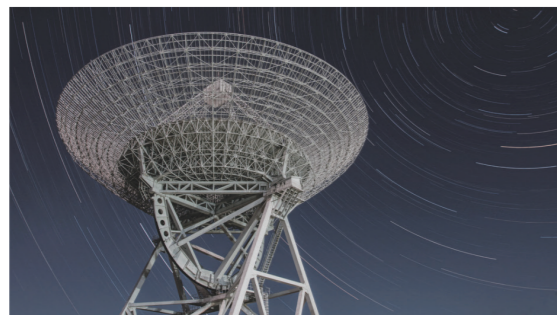

Communication equipment



Machine tool



Detection and analysis equipment



Printing equipment



Aerospace area



Semiconductor processing equipment

Grease Usage

Precautions Grease Usage

1. The internal hidden parts of the cup-shaped combined and hat-shaped hollow combined reducer before delivery have been sealed into the grease, but the grease needs to be injected and applied when assembling the wave generator.
2. The input and output end of harmonic reducer must be designed with strict sealing structure. Skeleton oil seal is recommended for dynamic sealing. O-ring or sealant is recommended for static sealing and the sealing surface must not be skewed or damaged.
3. Use the recommended semi-fluid grease for the reducer, and avoid mixing with other greases.
4. The use of grease must be carried out in accordance with the requirements of the instruction. Please note that the amount of grease injected and applied is different in different models.
5. In the use of reducer, if the wave generator is always in the state of facing up, may cause poor lubrication, at this time should increase the amount of grease injection or consult our company.
6. The performance of the grease will change with the temperature, and the higher the temperature, the faster the deterioration. In order to ensure the grease is always in good condition, the heat balance temperature at the high temperature end of the reducer should be lower than 70°C, and the temperature rise should be less than 40°C.
7. The wear of the moving parts of the reducer is mainly affected by the performance of the grease. Under the condition of conditions, the reducer should be replaced with the grease every 3000 hours.

Precautions Grease Usage

WCSG, WSHG series apply grease as per the following table

Amount of grease applied

Unit: g

Size	Grease area					D
	A	B	C			
			Horizontal use	Vertical use Upward Down		
14	0.3	0.3	6	8 9	0.3	
17	0.5	0.5	10	12 14	0.5	
20	0.8	0.8	16	18 21	0.8	
25	1.5	1.5	30	35 40	1.5	
32	3	3	60	70 80	3	

Grease area

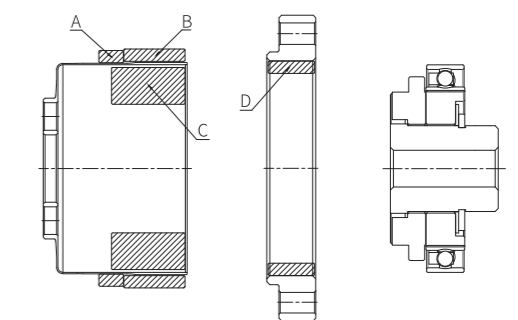

WCSG-1 series

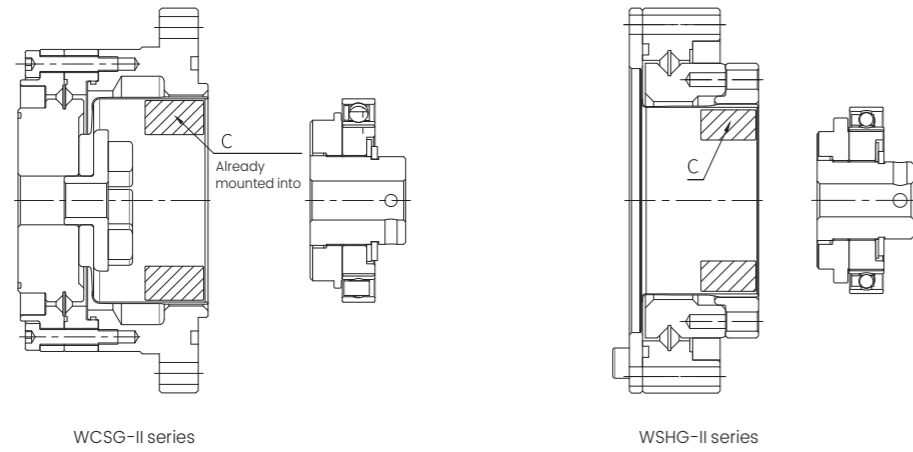

Pls. apply the grease for WSHG-III Series according to the following requirements

Amount of grease applied

Size	Grease area	
	C1	
14	5.5	
17	9.6	
20	10.3	
25	16	
32	26	

Grease area

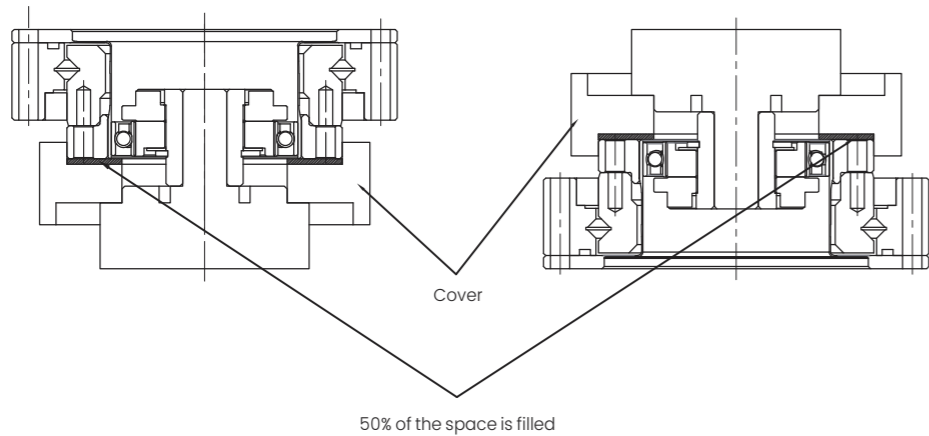
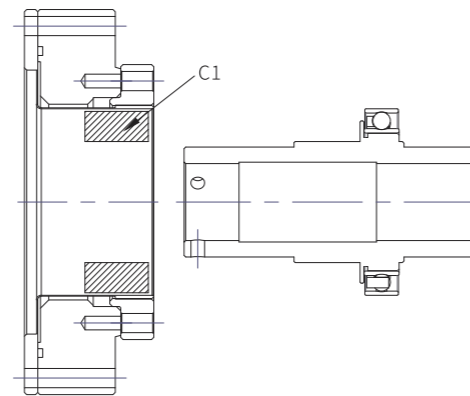

Pls. apply the grease for WSHD and WCSD Series according to the following requirements

Amount of grease applied

Size	Grease area		
	C		
	Horizontal use	Vertical usev	
		Upward	Down
14	3	4	5
17	5	6	7
20	8	9	11
25	16	19	21
32	36	42	48

Unit: g

Grease area

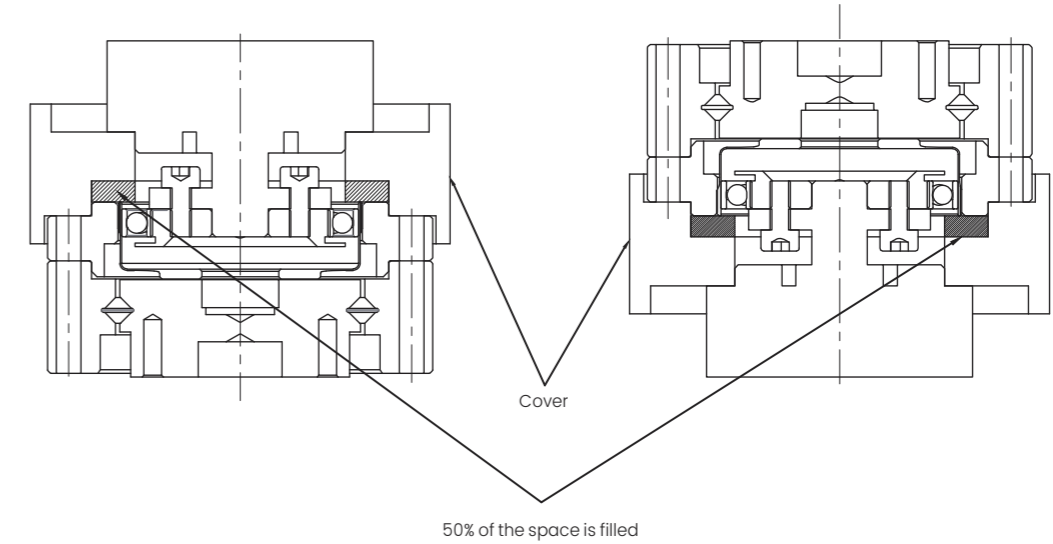
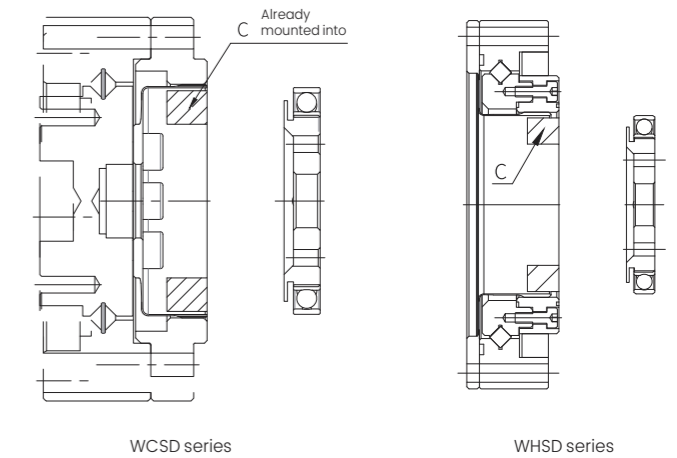

Grease Change Time

The abrasion of the moving parts of reducer is greatly affected by the performance of the grease. The performance of the grease will change according to the temperature, the higher the temperature, the faster the deterioration, so it is necessary to change the grease. As shown in the figure below, when the average load torque is lower than the rated torque, the replacement time benchmark of the grease can be determined according to the relationship between the grease temperature and the total revolutions of the wave generator. When the average load torque exceeds the rated torque, the grease replacement time benchmark is calculated by the following formula.

$$L_{GT} = L_{GTn} \times \left(\frac{T_r}{T_{av}} \right)^3$$

The formula for calculating when the average load torque exceeds the rated torque

L_{GT}	Change time beyond rated torque	Speed	—
L_{GTn}	Change time below rated torque	Speed	Refer to the figure below
T_r	The rated torque	Nm, kgfm	Refer to each series "parameter table"
T_{av}	Average load torque on the output side	—	Depending on the use condition

The sign of the formula

Grease change time: L_{GTn}
(when average load torque is lower than rated torque)

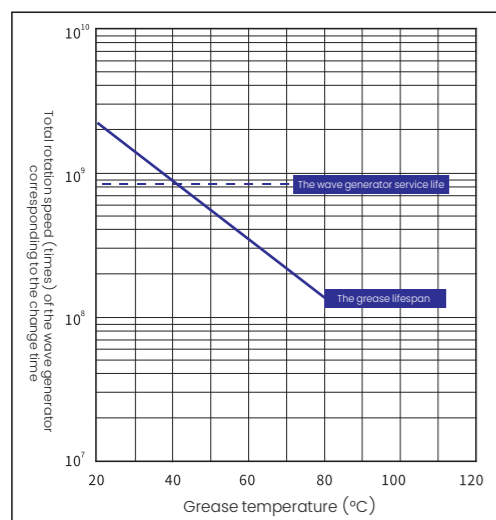

※ The service life of the wave generator indicates that the failure rate is 10%

Other notes:

1. Avoid mixing with other greases. In addition, when assembling to the device, please place the reducer in a separate housing.
2. When the wave generator is in an upward-facing state and rotating in a single direction at a low speed with a fixed load (input speed: less than 1000r/min), the use of reducer may cause poor lubrication, please consult Wanshsin.
3. Grease leakage for combined type. Although the combined type has been designed and constructed in response to grease leakage measures, but according to the use of the environment for sealing mechanism strengthening.

Warranty

WANSHSIN harmonic reducer warranty period and warranty scope is as follows:

Warranty Period

On the condition under normal assembly and lubrication state recorded in the product operation manual,

The warranty period is either one year or the product runs up to 8,000 hours.

Warranty Scope

Wanshsin is responsible for the repair or replacement of the product in case of failure caused by the manufacturing defects.

But the followings are not covered:

- (1) failure is caused by improper operation or illegal use.
- (2) failure is not caused by transformation or repair not by Wanshsin
- (3) failure not caused by the product.
- (4) Wanshsin is not responsible for the failure caused by natural disasters.

Moreover, the warranty here refers to the warranty of this product.

The company shall not be responsible for other losses caused by the failure of the product, the man-hours and expenses related to disassembling and assembling the equipment, etc.

Precautions for safety use

 **Warning** Error in operation may result in death or serious injury.

 **Attention** Indicates that the wrong operation may result in injuries and property damage.

About the scrap

 **Attention** Please treat according to industrial waste standard.
Note: when scrapping, please treat as industrial waste.



Design attentions (be sure to read the instructions when designing)

 Attention	<p>Please use under regulated conditions</p> <p>When using reducer, please comply with the following conditions.</p> <ol style="list-style-type: none"> 1. Ambient temperature: 0~40°C. 2. Do not splash water, oil, etc. 3. Non-corrosive, explosive gas. 4. No dust such as metal powder. 	<p>please install according to the specified precision</p> <ol style="list-style-type: none"> 1. Assembly method, order, please follow the product catalog. 2. Tightening method (using bolts, etc.), please follow our advice. 3. If not assembled correctly, the operation may lead to vibration, shorten the service life, precision decline, damage and other faults.
	<p>please install according to the specified precision</p> <ol style="list-style-type: none"> 1. Please design and assemble various parts correctly to ensure that they can meet the installation precision recommended in the product catalog. 2. Failure to meet the specified precision may lead to vibration, shorten service life, precision decline, damage and other faults. 	<p>Please use the specified grease</p> <ol style="list-style-type: none"> 1. Do not use the grease recommended by Wanshsin may shorten the service life of the product. In addition, please change the grease according to the specified conditions. 2. The combined product has been pre-sealed with grease. Please do not mix with other greases.

Notes for use (please be sure to read the manual when running)

 Attention	<p>Please handle the products and components with care</p> <ol style="list-style-type: none"> 1. Do not use a hammer and other hard hit each component and combination unit. In addition, please make sure that there are no cracks, dents, etc. caused by falling, etc. Otherwise, the product will be damaged. 2. Performance cannot be guaranteed when used in a damaged state. It may also cause damage and other faults. 	<p>When in use, do not exceed the allowable torque</p> <ol style="list-style-type: none"> 1. Apply torque do not exceed the maximum allowable torque of the moment. Otherwise the bolts in the tightening part may become loose, shake, and damage, leading to product failure. 2. If the output shaft is directly connected to the joint arm, it may be damaged due to the joint arm collision, the output shaft cannot be controlled.
	<p>Do not change spare parts</p> <ol style="list-style-type: none"> 1. The parts of the product are made of matching processing. When used in conjunction with other suites, there is no guarantee that a particular performance will be achieved. 	<p>Do not disassemble the combined product</p> <ol style="list-style-type: none"> 1. It is strictly prohibited to disassemble and reassemble combined products. Otherwise its original performance will not be restored.

Use of grease

 Warning	<p>stallation precautions</p> <ol style="list-style-type: none"> 1. Splashing into the eye may cause inflammation. When operating, please wear protective glasses to avoid splashing into the eyes. 2. Skin contact may cause inflammation. When operating, please wear protective gloves to avoid contact with the skin. 3. Do not swallow (can cause diarrhea, vomiting, etc.). 4. Be careful not to cut your finger when opening the container, please wear protective gloves. 5. Please keep it out reach of children. 	<p>Emergency Treatment</p> <ol style="list-style-type: none"> 1. In case of splash into the eyes, rinse immediately with water for 15 minutes and receive medical treatment. 2. In case of contact with skin, wash thoroughly with water and soap. 3. If swallowed, do not force it to vomit, should immediately accept medical treatment.
	<p> Attention</p> <p>Storage Method</p> <ol style="list-style-type: none"> 1. After use, please seal it to prevent dust, moisture and other mixed. Please keep it in the shade, away from direct sunlight. 2. For long-term inventory of products, it is recommended to confirm whether the performance and rust prevention is good. 3. Please refer to the delivery drawing for details of surface treatment. 	<p>Disposal of waste oil and waste containers</p> <ol style="list-style-type: none"> 1. The decree provides a treatment that users are obliged to implement. Please handle it correctly according to relevant laws and regulations. If you are not clear, please consult Wanshsin. 2. Do not put pressure on empty containers, pressure may cause it to crack. 3. Do not weld, heat, open or cut the container, otherwise there could be an explosion and the remains inside could catch fire.