

PRECISION HARMONIC REDUCER

Committed to building a world-class electromechanical brand



 **CONTENTS****About Us**

Company Profile	01
Transmission Principle	03
Named Rules	04
Technical Service	06

Categories

WCSF-I Series	08
WCSF-II Series	16
WCSG-I Series	25
WCSG-II Series	33
WSHG-I Series	41
WSHG-II Series	49
WSHG-III Series	57
WSHG-IV Series	65
WSHD-I Series	73
WCSD-I Series	81

Usage Information

Installation	89
Installation Accuracy	97
Applications	102
Grease Usage	103
Warranty	107
Safety Precautions	108

Company Profile

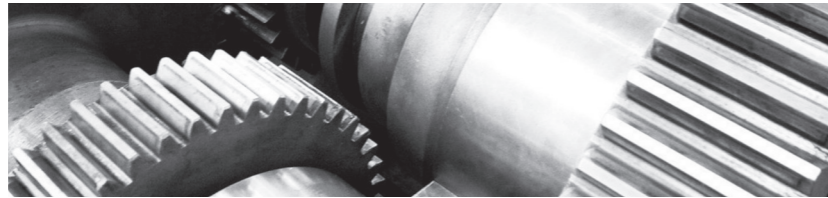

WANSHSIN SEIKO(HUNAN) CO.,LTD.(hereafter referred to as "WANSHSIN") is professional gear motor manufacturer intergrates R&D, production,sales and-service.WANSHSIN mainly manufactures high precision gear motors which are widely used in robots,machine tools,solid garages and other industrial automation.As a gear motor manufacturer and complete intelligent automation solutions provider,WANSHSIN introduced advanced import processing equipment, adopted advanced technology, to meet the strict high quality requirement for worldwide customers.All efforts made WANSHSIN a reputable and high quality brand in domestic gear motor industry.

To satisfy domestic and foreign customers' requirements, WANSHSIN fully opened the international strategic layout, determined to follow the path of building a strong enterprise for a stronger country, WANSHSIN pays more attention to the quality improvement of current products and development of new products, and successively introduced high-tech talents, both domestic and international. In the future,WANSHSIN will continuously keep the faith that "Committed to building a world-class electromechanical brand"and strive to the development of the industrial intelligent system of the world.



Product Pictures

WCSF-I Series Reducer



WCSF-II Series Reducer



WCSG-I Series Reducer



WCSG-II Series Reducer

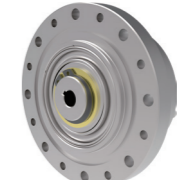

WSHG-Series Reducer



WSHG-II Series Reducer



WSHG-III Series Reducer



WSHG-IV Series Reducer

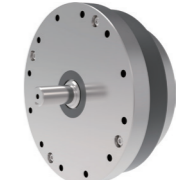

WSHD- I Series Reducer



WCSD- I Series Reducer



Transmission Principle

Transmission Principle

The harmonic gear drive was invented by an American inventor, C. W. Musser in 1955. It is a new type of transmission, which uses the elastic deformation of flexible components for motion or power transmission. It breaks through the mode of using rigid components to realize mechanical drive, thus obtaining a series of special functions that other transmission cannot reach. Its name comes from the deformation process of the intermediate flexible component, which is a symmetrical harmonic.

Composition

Flex Spline

The Flex Spline is a thin-cup-shaped metallic elastic component, with external teeth around. The circumference of its mouth opening, when the wave generator, is inserted into the flex spline's mouth opening, the flex spline becomes, Deformed into an elliptical shape, it is attached to the output shaft.

Circular Spline

The circular spline is a rigid ring-shaped component with teeth along its inner circumference. The number of teeth is usually two more than the accompanying flex spline has, it is usually secured to the machine's casing.

Wave Generator

Small ball bearings are built in the outer circumference of its elliptical cam, and the bearings' inner faces are fixed to the cam. The outer faces are subjected to elastic. Deformation as the bearings move. Normally, it is mounted to the input shaft.

Deceleration principle

As a reducer, harmonious waves are generally driven by wave generator with fixed rigid spline and output by flexible spline. When wave generator is installed inside the inner ring of flexible spline, flexible spline is forced to go through elastic transformation and becomes an elliptical shape; the flexible spline teeth of long shaft insert into the gear groove of rigid spline to realize complete engagement; the gear teeth of the two splines of the short shaft are not contacted at all but disengaged. Between engagement to disengagement, gear teeth are in engaging-out or engaging-in status. When the wave generator rotates continuously, the flexible spline is forced to deform constantly, and the gear teeth of the two gears change their working status repeatedly in the engaging-in, engagement, engaging-out and disengagement, generating the so-called staggered teeth motion and realizing the motion transmission between active wave generator and flexible spline.

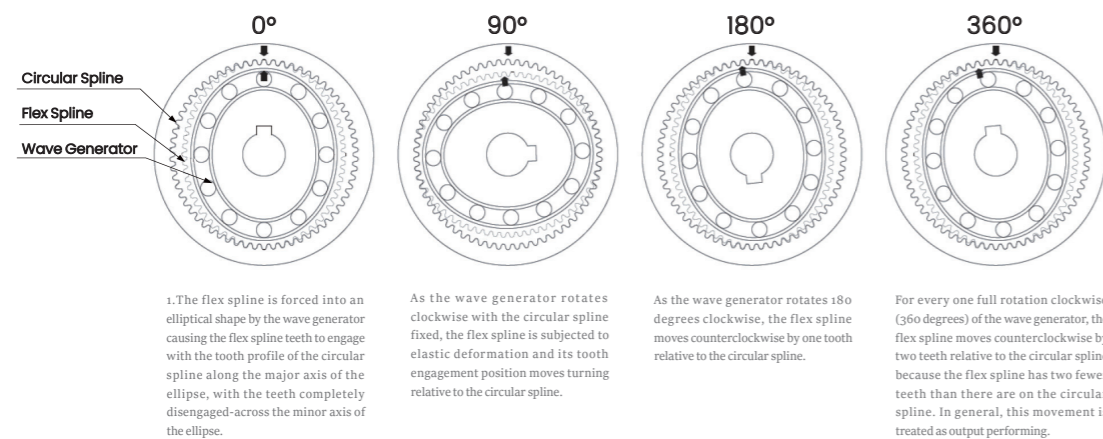

Named Rules

① ② ③ ④ ⑤

WCSG - 25 - 100 Type Standard & Customized

Model	Size	Ratio				Type	Standard & Customized
WCSG WCSF	14	50	80	100		I. Standard type II. Cross slider coupling type	Standard: Blank SP: Customized
	17	50	80	100			
	20	50	80	100	120		
	25	50	80	100	120		
	32	50	80	100	120		

Model	Size	Ratio				Type	Standard & Customized
WSHG	14	50	80	100		I. Standard type	Standard: Blank SP: Customized
	17	50	80	100		II. Cross slider coupling type	
	20	50	80	100	120	III. Hollow shaft type	
	25	50	80	100	120	IV. Shaft input type	
	32	50	80	100	120		

Model	Size	Ratio				Type	Standard & Customized
WCSG	14	50	80	100		I. Standard type	Standard: Blank SP: Customized
	17	50	80	100			
	20	50	80	100	120		
	25	50	80	100	120		
	32	50	80	100	120		

Model	Size	Ratio				Type	Standard & Customized
WSHD	14	50	80	100		I. Standard type	Standard: Blank SP: Customized
	17	50	80	100			
	20	50	80	100	120		
	25	50	80	100	120		
	32	50	80	100	120		

Note

① Model example

*W--WANSHSIN + structure code

The product code is composed by the flex spline shape, length, and the torque (high or normal).

C for CUP type, H for hollow type, S for standard length, D for short length.

② Size Code

Size Code	14	17	20	25	32
Diameter for circular flex spline	35.6	43.2	50.8	63.5	81.3

③ Ratio

④ Connection Type

Type I: Standard type, the input shaft is matched with the inner hole of the elliptical cam and connected by a flat key.

Type II: Cross slider coupling type, the input shaft and cam are connected by cross slider coupling.

Type III: Cylindrical hollow type, the input end part and the hollow elliptical cam are connected by screws.

Type IV: Solid shaft input type, high speed end of reducer comes with input shaft.

⑤ Special specifications such as shape and performance

Blank = Standard, SP = Customized, LW = Light Weight.

Starting Torque (N.cm)

Model	14			17			20				25				32			
	50	80	100	50	80	100	50	80	100	120	50	80	100	120	50	80	100	120
WCSG-I/II	4.1	2.8	2.5	6.1	4	3.4	7.8	4.9	4.3	3.8	15	9.2	8	7.3	31	19	18	15
WSHG-I/II	4.1	2.8	2.5	6.1	4	3.4	7.8	4.9	4.3	3.8	15	9.2	8	7.3	31	19	18	15
WSHG-III	8.8	7.5	6.9	27	25	24	36	33	32	31	56	50	49	48	85	74	72	68
WSHG-IV	5.7	4.4	3.7	9.7	7.2	6.5	14	11	9.9	9.3	22	15	14	13	41	29	27	24
WCSD	4		2.5	6		3.4	8		4.6		14.5		8.2		29		18	
WSDH	5.6		4.3	17.1		15.3	22.5		19.8		35		31		54		45	

Technical Service

Rated Technical Table

Rated technical table terms:

(1) Rated Torque: Allowable continuous load torque when the input speed is 2000r / min

(2) Allowable peak torque at start and stop condition: When starting, there will be a load larger than the normal torque applied to the reducer according to the moment inertia of load, and current rating table value is the allowable value of peak torque.

(3) Maximum allowable load torque:

3.1 Load torque, when the input speed changes, the average value of the load torque needs to be calculated.

3.2 The value in the rating table indicates the allowable value of the average load torque.

3.3 When the average load torque exceeds the rated value, it may cause early deterioration of lubricant due to heat generation, and gear may be abnormal.

(4) Instant allowable maximum torque: In addition to the normal load torque and the load torque at the start and stop, there are also unpredictable shock torques from the outside. The values in the rating table indicate the current allowable values.

(5) Moment of inertia: Means the moment of inertia on the shaft of each model of wave generator.

(6) Direction of rotation and ratio:

In general use, the wave generator is worked as the active part, the situation described here is on the condition that the wave generator is the active part.

When circular spline is fixed: The actual reduction ratio is equal to the reduction ratio in the rated technical table. The rotating direction of the flex spline is opposite to the wave generator.

When flex spline is fixed: The actual reduction ratio is equal to the reduction ratio in the rated technical table plus one. The rotating direction of the Circular spline is the same as the wave generator.

E.g.: WSHG25-120

Model is 25, the ratio is 120 in the rated technical table.

The real ratio =120 when the Circular spline is fixed.

And the real ratio =120+1=121 when flex spline is fixed.

(7) Wanshin harmonic reducer wave generator has two structures: one is an automatic centering type with a centering structure, and the other one is an integrated type without a centering structure.

As show below:



Integrated Wave Generator

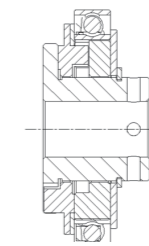

Integrated Wave Generator

The structure of the integrated wave generator is a cam equipped with a flexible bearing, which is simple and low weight. The structure of the Automatic Centering Wave Generator is a European-style coupling with a cam and a flexible bearing, automatically aligning when rotating, reducing the influence of small-scale non-concentricity. Starting Torque is generated instantaneously the reducer output starts to rotate by the transmission force of reducer input.

Model	Starting Torque(N.M)
11	≤0.8
14	≤1.25
17	≤2
20	≤3
25	≤5
32	≤8

Efficiency

Model 25-120, speed is 500~3000r/min, when ratio is 50~120, the efficiency is 75~90%; when ratio is 160, efficiency is 70~85%.

Noise

Under rated speed and load, the noise is less than 50dB.

Life Span

Under normal operation of rated speed and load, when the life span of the flexible bearing is 8000h, the life span of the harmonic reducer is 10000h. During life span test, the temperature rise does not exceed 45 °C.

High Accuracy

Adopting the most advanced design technology, ANSYS software simulation technology, the design error is reduced to less than 1 micron. WANSHSIN developed its independent intellectual property rights of flexible bearings, cross bearings, flex spline, circular spline. The machine tool used is also the most precise in the industry.

High Transmission Ratio

Designed according to international standards, the transmission ratio of the one-stage harmonic reducer can reach $i = 50 \sim 160$. And the structure is simple, with three coaxial basic components to achieve a high reduction ratio.

Large Load Capacity

The surface contact and large number of the arc-shaped flex spline tooth and circular spline tooth make the harmonic reducer load capacity higher than other transmission forms. Furthermore, application of cross bearings makes the load capacity greatly improved.

Compact design and Low Weight

Adopting integrated design and high-performance materials, harmonic reducer size and weight can be greatly reduced, compared with ordinary gear devices.

High Efficiency, Long Serving Life

Due to the use of high-strength, high-performance material, as well as the use of advanced surface heat treatment technology and surface coating technology, the surface wear resistance of key components has increased by more than three times, resulting in a greatly increased life span.

Stable Transmission, Shock-Free, Low-Noise

The key parts have high precision, small deformation, stable and smooth transmission, and high-performance due to the use of advanced 3D simulation design technology and high-precision processing technology. High-performance lubricants are also used, making it free of impact and low noise.

Operating principle of harmonic reducer

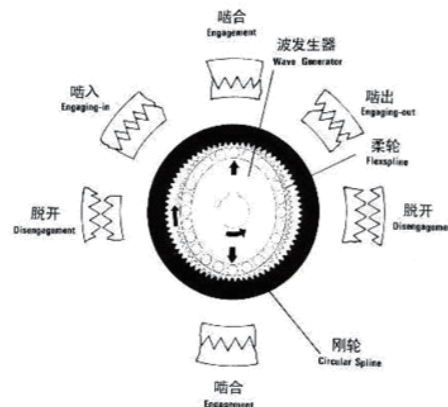

WCSF-I Series Reducer



WCSF-I series reducer

WCSF-I series flex spline is a cup-shaped standard structure. The input shaft is directly matched with the inner hole of the wave generator and connected by a flat key. Generally, the circular spline end is fixed and the flex spline output.

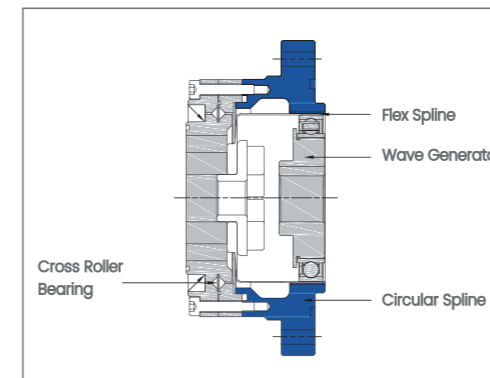

WCSF-I Series Features

1. Cup-shaped integrated cam structure
2. Compact and simple design
3. No backlash
4. Coaxial input and output
5. High positioning accuracy and rotation accuracy

WCSF-I Series Performance Parameter

Model	Ratio	Rated torque at input speed 2000r/min N*m	Allowable maximum torque at start and stop N*m	Maximum allowable load torque N*m	Instantaneous Maximum torque N*m	Maximum allowable input speed r/min	Allowable average input speed r/min	Backlash arc sec	Life Span hrs
14	50	5.4	18	6.9	35	8000	3500	20	12000
	80	7.8	23	11	47			20	15000
	100	7.8	28	11	54			20	15000
17	50	16	34	26	70	7000	3500	20	12000
	80	22	43	27	87			20	15000
	100	24	54	39	108			20	15000
20	50	25	56	34	98	6000	3500	20	12000
	80	34	74	47	127			20	15000
	100	40	82	58	147			20	15000
	120	40	87	49	147			20	15000
25	50	39	98	55	186	5500	3500	20	12000
	80	63	137	87	255			20	15000
	100	67	157	108	284			20	15000
	120	67	167	108	304			20	15000
32	50	76	216	108	382	4500	3500	20	12000
	80	118	304	167	568			20	15000
	100	137	333	216	647			20	15000
	120	137	353	216	686			20	15000

WCSF-I Series Dimensional Drawing

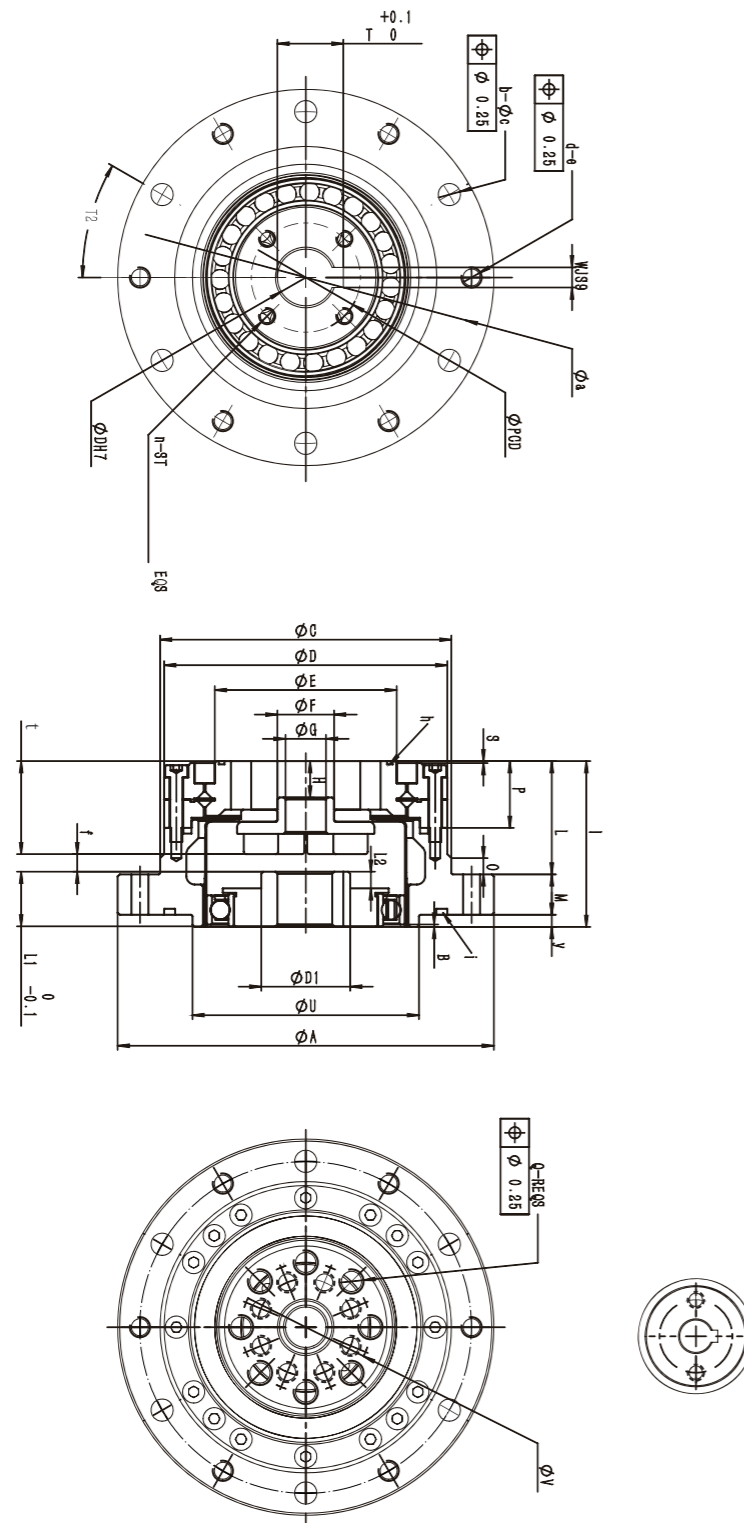

There are only 2 screw holes when the size is 14# and 17#

WCSF-I Series Dimension

Symbol	Model	14	17	20	25	32
ΦA h6		73	79	93	107	138
L1		10	12.5	13.5	14.5	16
ΦC h7		56	63	72	86	113
ΦD		55	62	70	85	112
ΦE		42.5	49.5	58	73	96
ΦF H7		11	10	14	20	25
ΦG		8	7	10	14.5	20
H		9.4	9.5	9	12	15
I		36	39	41	49	60
B		0.5±0.2	0.6±0.2	0.6±0.2	0.7±0.2	0.9±0.2
$\Phi D1$		14	16	20	22	30
L		27	29	28	36	45
M		7	8	10	10	12
Y		2	2	3	3	3
O		3.5	3.5	4	4.5	4.5
P		16.5	16.5	16.5	18.5	22.5
S		0.5	0.5	0.5	0.5	1
$\Phi Dh7$		6	8	11	14	14
ΦU H7		38	48	56	67	90
Φv		23	27	32	42	55
Q		6	6	8	8	8
R		M4×8	M5×10	M6×9	M8×12	M10×15
t		7	9.4	12.8	16.3	16.3
WJS9		2	3	4	5	5
Φa		65	71	82	96	125
b		6	6	6	8	12
c		4.5	4.5	5.5	5.5	6.6
d		6	6	6	8	12
e		M4	M4	M5	M5	M5
h		29.5×0.5	34.5×0.5	40.64×1.14	53.3×1	70.5×2
i		49.5×2	55.5×2	66.5×2	79.5×2	104.5×2
f		4.2	2.4	4.4	6.5	6.3
t		21.4	23.5	23	26	35.2
T2		30°	30°	30°	22.5°	15°
L2		2.9	4.9	4.1	5.4	4.1
n		2	2	4	4	4
ST		M4	M4	M4	M5	M5
PCD		18	22	25	32	36
Weight(Kg)		0.51	0.66	0.95	1.48	3.18

WCSF-14-XXX-I

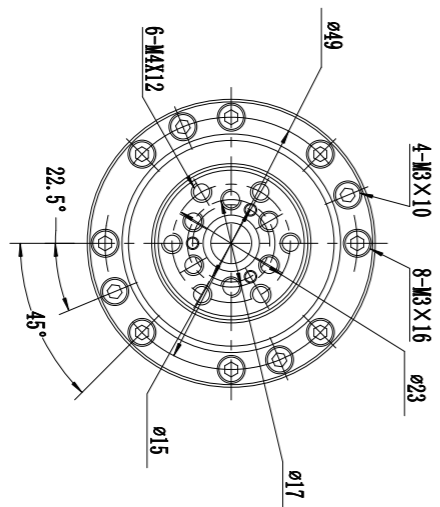
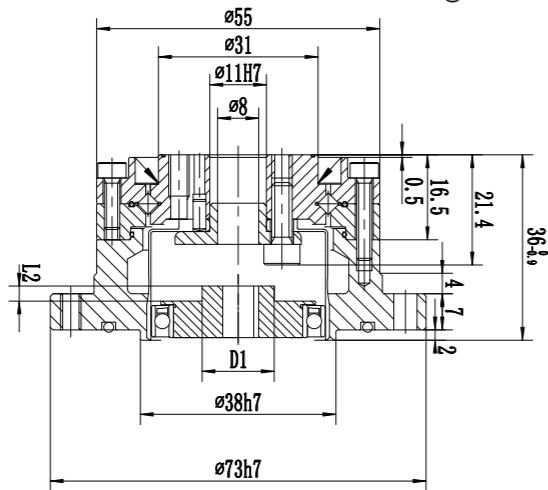
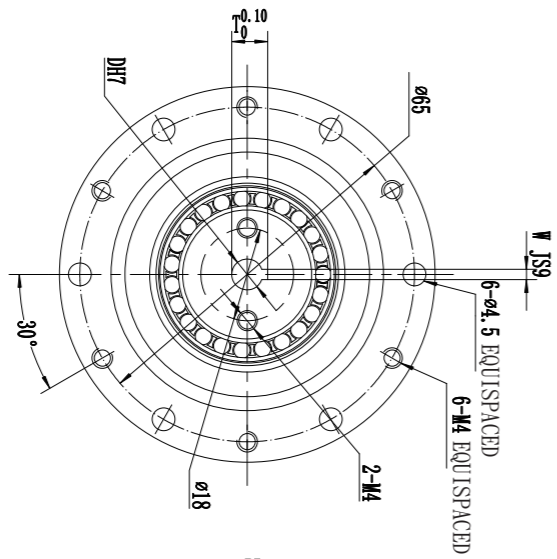

L1	L2	D1	D	T	W
10	2.9	14	8	9.4	3

WCSF-17-XXX-I

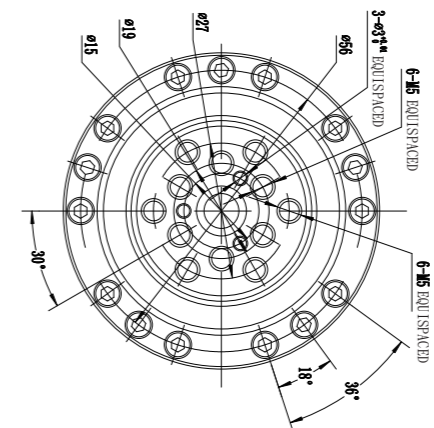
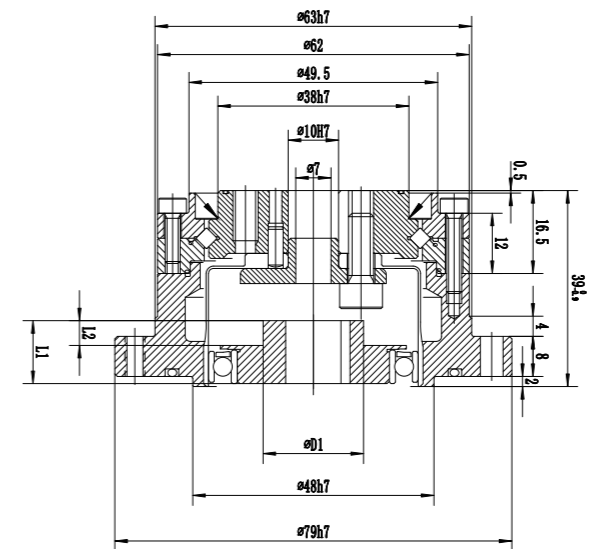
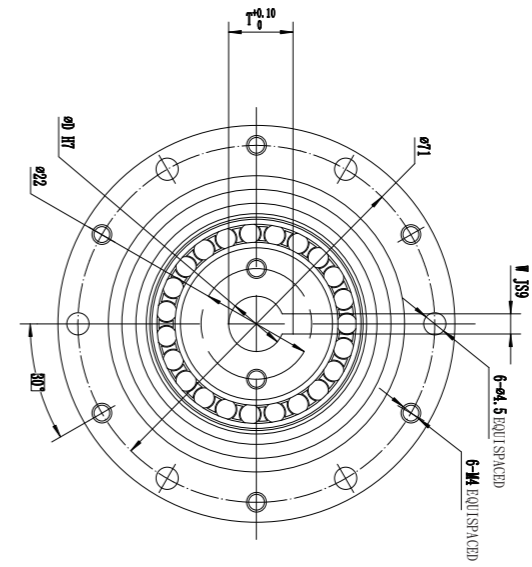

L1	L2	D1	D	T	W
12.5	4.9	20	11	12.8	4
22	14	16.3	5		

WCSF-32-XXX-I

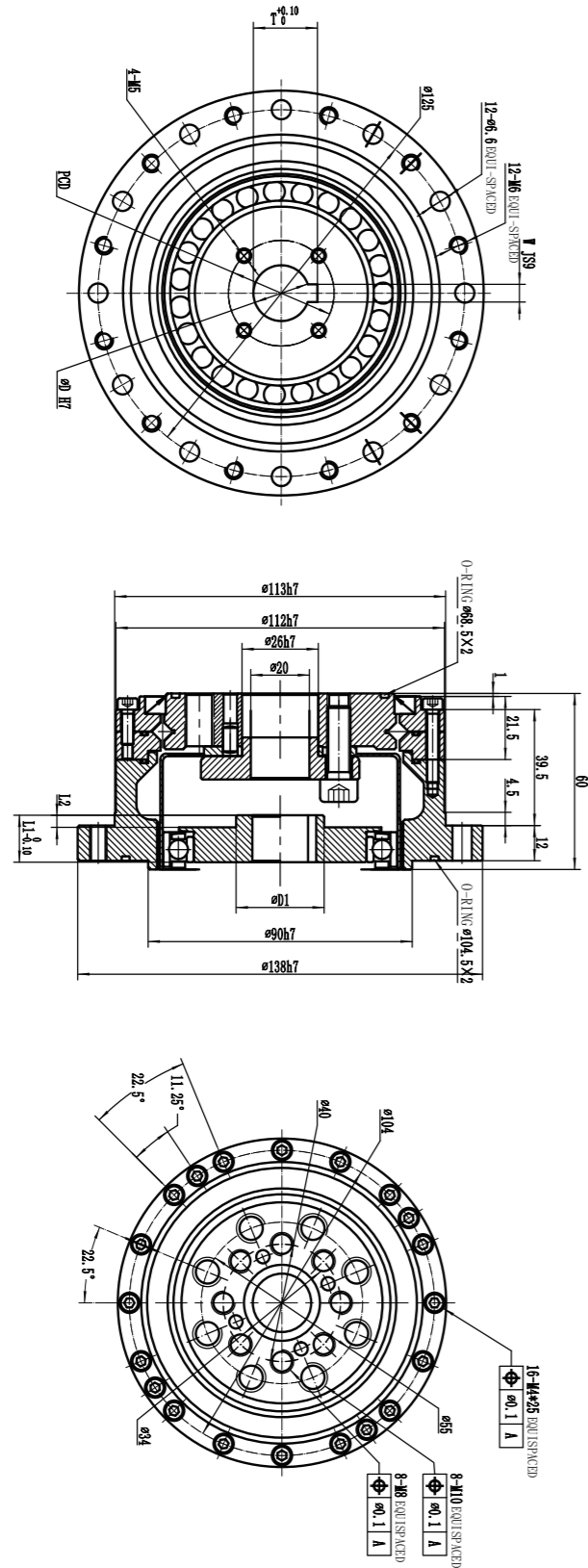

14	14	14	14	14	14	14	14	14	14
16	16	16	16	16	16	16	16	16	16
17	17	17	17	17	17	17	17	17	17
20	20	20	20	20	20	20	20	20	20
25	25	25	25	25	25	25	25	25	25
32	32	32	32	32	32	32	32	32	32

WCSF-II Series Reducer



WCSF-II Series Reducer

WCSF- II Series flex spline is a cup-shaped standard structure. The input shaft is connected with the inner hole of the wave generator through the cross slider coupling. Generally, the circular spline end is fixed and the flex spline is the output end.

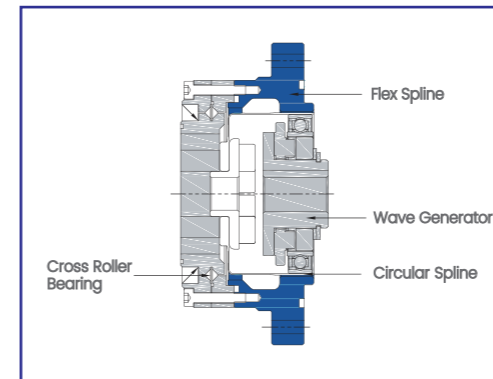

WCSF-II Series Features

- 1.Cup-shaped integrated cam structure
- 2.Compact and simple design
- 3.No backlash
- 4.Coaxial input and output
- 5.High positioning accuracy and rotation accuracy

WCSF-II Series Performance Parameter

Model	Ratio	Rated torque at input speed 2000r/min N*m	Allowable maximum torque at start and stop N*m	Maximum allowable load torque N*m	Instantaneous Maximum torque N*m	Maximum allowable input speed r/min	Allowable average input speed r/min	Backlash arc sec	Life Span hrs
14	50	5.4	18	6.9	35	8000	3500	20	12000
	80	7.8	23	11	47			20	15000
	100	7.8	28	11	54			20	15000
17	50	16	34	26	70	7000	3500	20	12000
	80	22	43	27	87			20	15000
	100	24	54	39	108			20	15000
20	50	25	56	34	98	6000	3500	20	12000
	80	34	74	47	127			20	15000
	100	40	82	58	147			20	15000
	120	40	87	49	147			20	15000
25	50	39	98	55	186	5500	3500	20	12000
	80	63	137	87	255			20	15000
	100	67	157	108	284			20	15000
	120	67	167	108	304			20	15000
32	50	76	216	108	382	4500	3500	20	12000
	80	118	304	167	568			20	15000
	100	137	333	216	647			20	15000
	120	137	353	216	686			20	15000

WCSF-II Series Dimensional Drawing

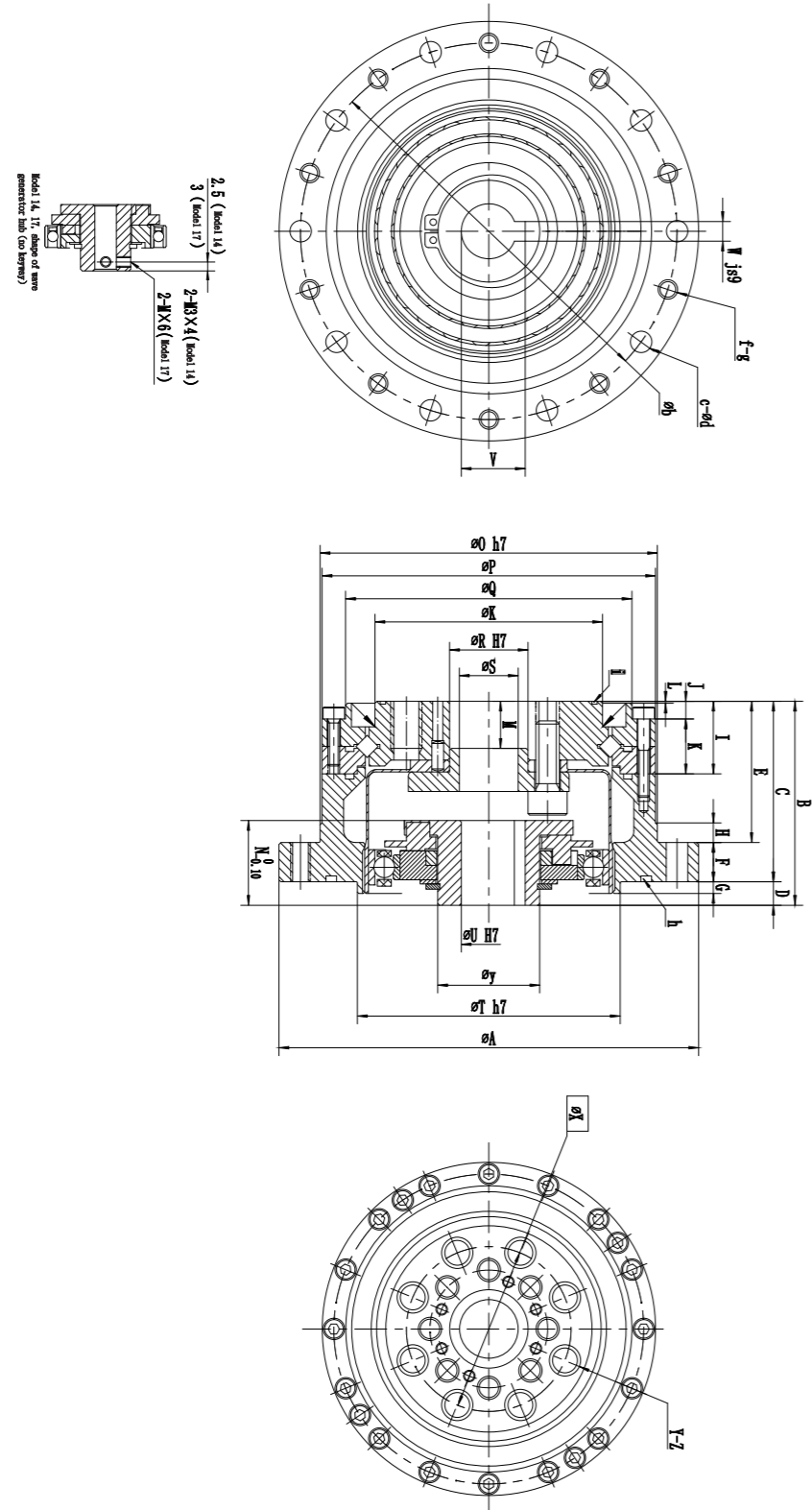

WCSF-II Series Dimension

Model Symbol	14	17	20	25	32
ϕA	73	79	93	107	138
B*	41 ^{-0.9}	45 ^{-0.9}	45.5 ^{-1.0}	52 ^{-1.0}	62 ^{-1.1}
C	34	37	38	46	57
D	7 ^{-0.8}	8 ^{-0.9}	7.6	6 ^{-1.0}	5 ^{-1.1}
E	27	29	28	36	45
F	7	8	10	10	12
G	2	2	3	3	3
H	3.5	4	5	5	5
I	16.5	16.5	16.5	18.5	22.5
J	4.5	4.5	4	4.5	5.5
K	12	12	12.5	14	17
L	0.5	0.5	0.5	0.5	1
M	9.4	9.5	9	12	15
N	17.6	19.5	20.1	20.2	22
ϕO h7	56	63	72	86	113
ϕP	55	62	70	85	112
ϕQ	42.5	49.5	58	73	96
ϕR H7	11	10	14	20	26
ϕS	6	7	10	15	20
ϕT h7	38	48	56	67(68)	90
ϕU H7	6	8	12	14	14
V	-	-	13.8 ^{+0.1}	16.3 ^{+0.1}	16.3 ^{+0.1}
W js9	-	-	4	5	5
X	23	27	32	42	55
Y	6	6	8	8	8
Z	M4*8	M5*10	M6*9	M8*12	M10*15
a	2	2	2.4	2.8	3
ϕb	65	71	82	96	125
c	6	6	8	8	12
ϕd	4.5	4.5	5.5	5.5	6.6
g	M4	M4	M5	M5	M6
f	6	6	6	8	12
h	29*0.5	34.5*0.8	40.5*1.0	53*1.0	S71
i	S50	S56	S67	S80	S105
ϕk	31	38	45	58	78
ϕy	14	18	21	26	26
Weight (Kg)	0.52	0.68	0.98	1.5	3.2

WCSF-14-XXX-II

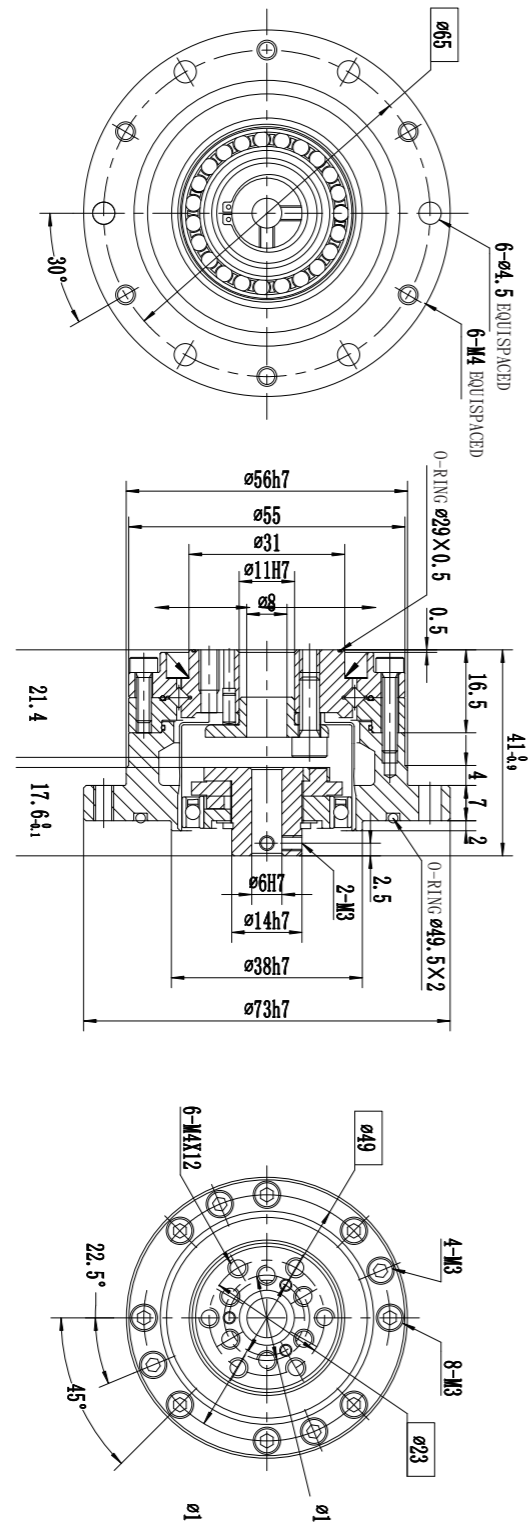

WCSF-17-XXX-II

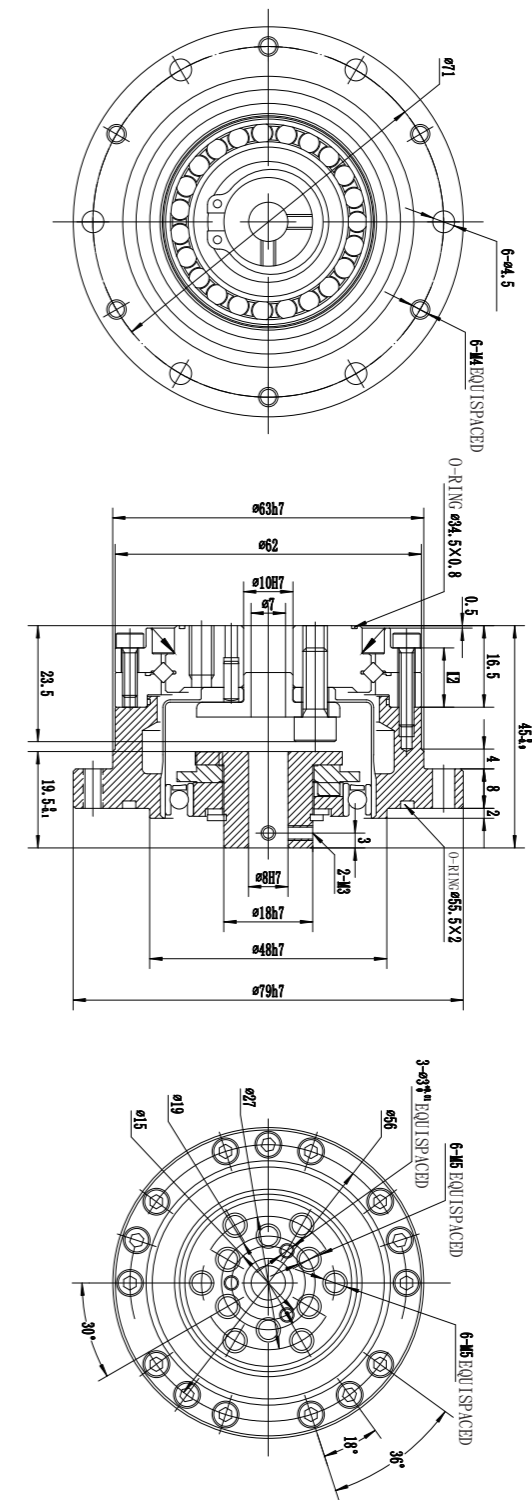

WCSF-20-XXX-II

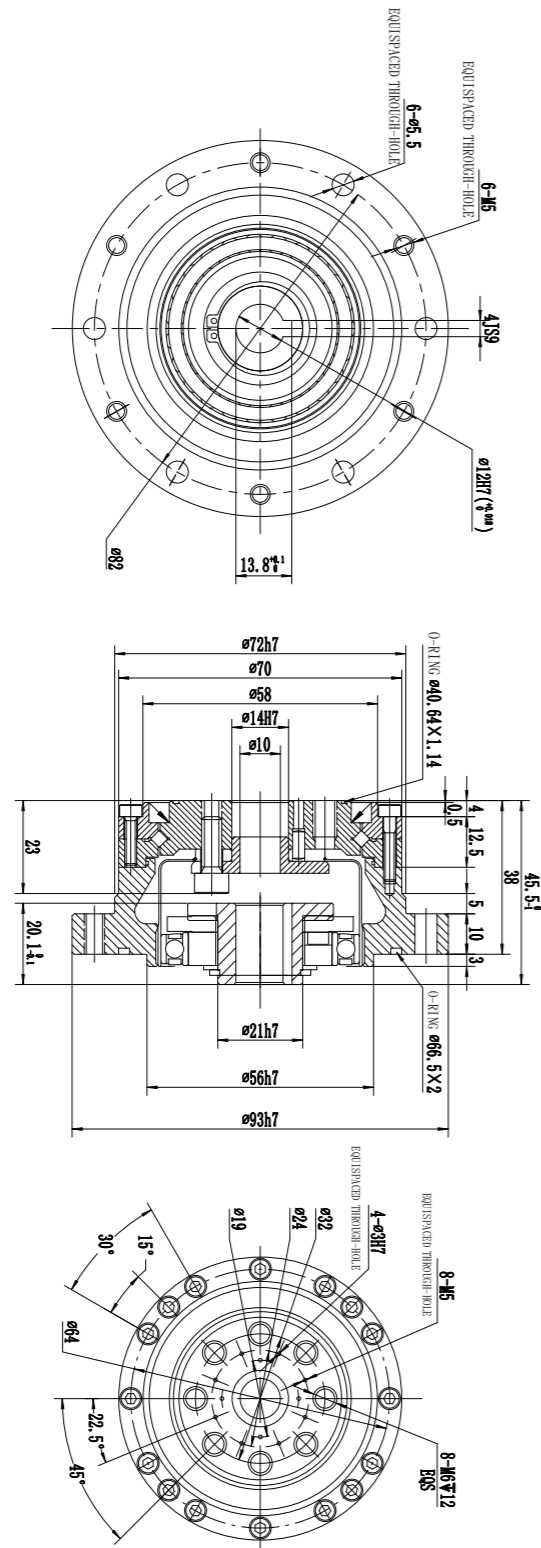

WCSF-25-XXX-II

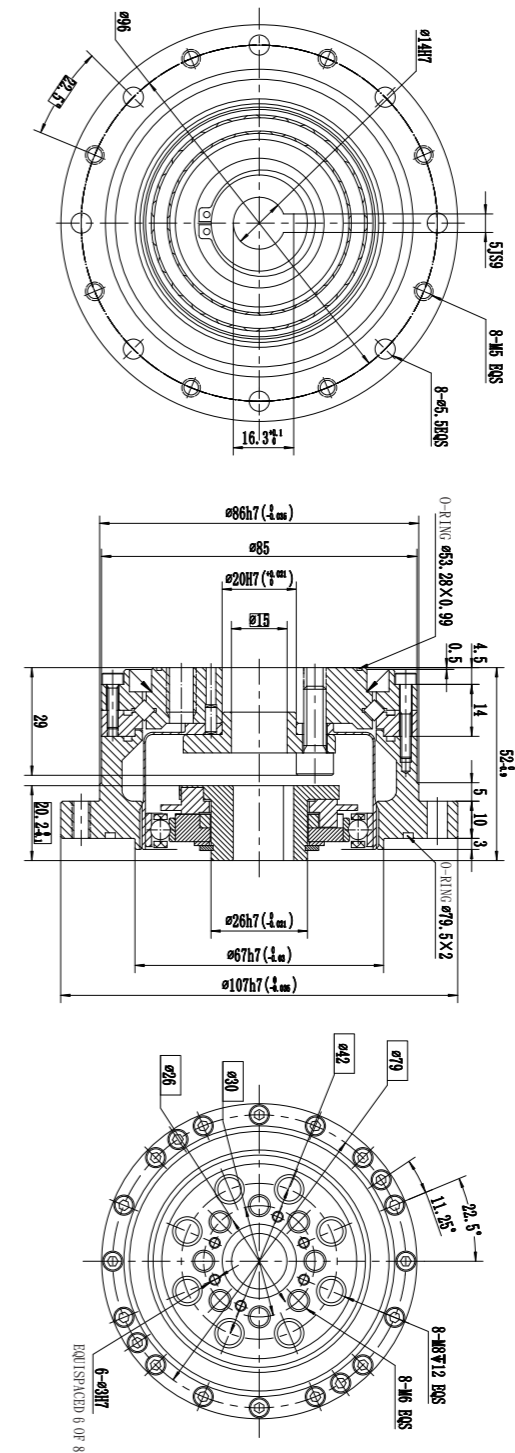

WCSF-32-XXX-II

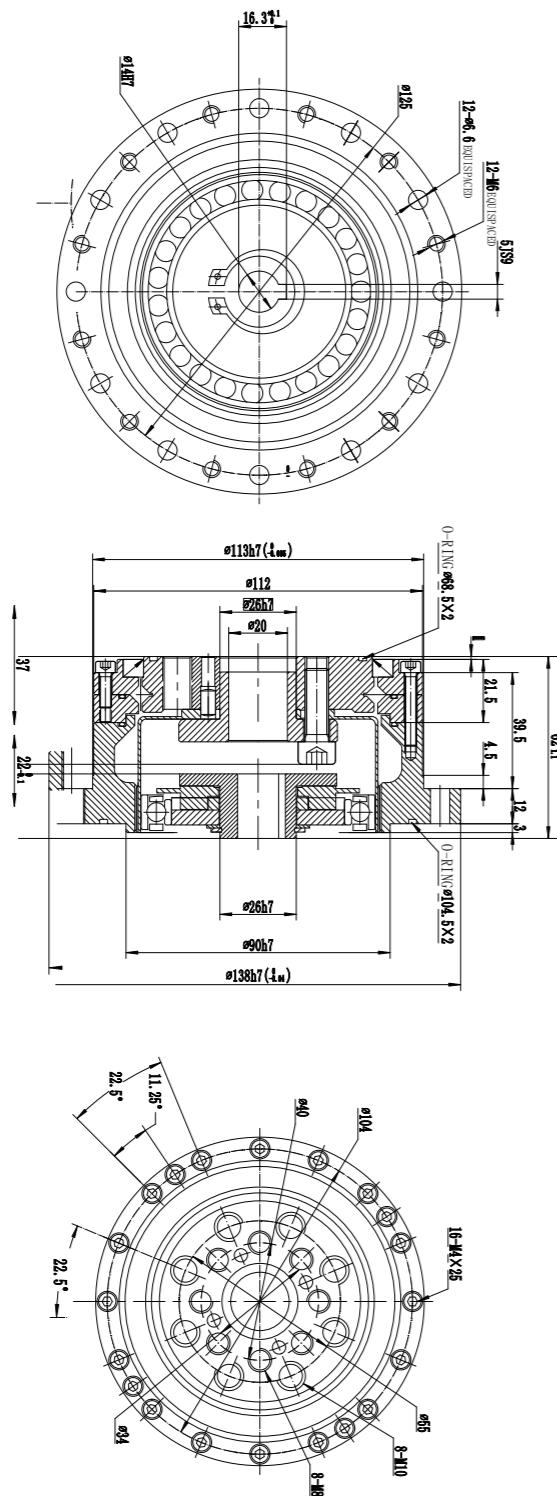

WCSG-I Series Reducer

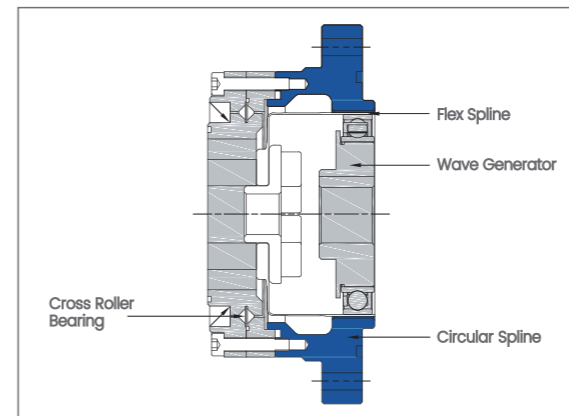

WCSG-I series reducer

WCSG-I series flex Spline is a cup-shaped standard structure. The input shaft is connected with the inner hole of the wave generator through the cross-slider coupling. Generally, the circular spline end is fixed and the flex spline is the output end.

WCSG-I Series Features

1. WCSG series: high torque
2. Torque capacity is 30% higher than WCSF series
3. Service life is 43% longer than WCSF series
3. Cup-shaped standard structure
4. Compact and simple design
5. No backlash, input- output coaxial
6. High positioning and rotation accuracy

WCSG-I Series Performance Parameter

Model	Ratio	Rated torque at input speed 2000r/min N*m	Allowable maximum torque at start and stop N*m	Maximum allowable load torque N*m	Instantaneous Maximum torque N*m	Maximum allowable input speed r/min	Allowable average input speed r/min	Backlash arc sec	Life Span hrs
14	50	6.3	21	8	42	8000	3500	20	10000
	80	9	27	13	55			20	15000
	100	9	33	13	63			15	15000
17	50	19	40	31	82	7000	3500	20	10000
	80	26	50	32	102			20	15000
	100	28	63	46	129			15	15000
20	50	30	66	40	115	6000	3500	20	10000
	80	40	87	55	149			20	15000
	100	47	97	58	172			15	15000
	120	47	102	58	172			15	15000
25	50	46	114	65	218	5500	3500	20	10000
	80	74	160	102	299			20	15000
	100	78	184	126	332			15	15000
	120	78	196	126	356			15	15000
32	50	89	253	126	448	4500	3500	20	10000
	80	138	356	196	665			15	15000
	100	160	370	253	757			15	15000
	120	160	413	253	803			15	15000

WCSG-I Series Dimensional Drawing

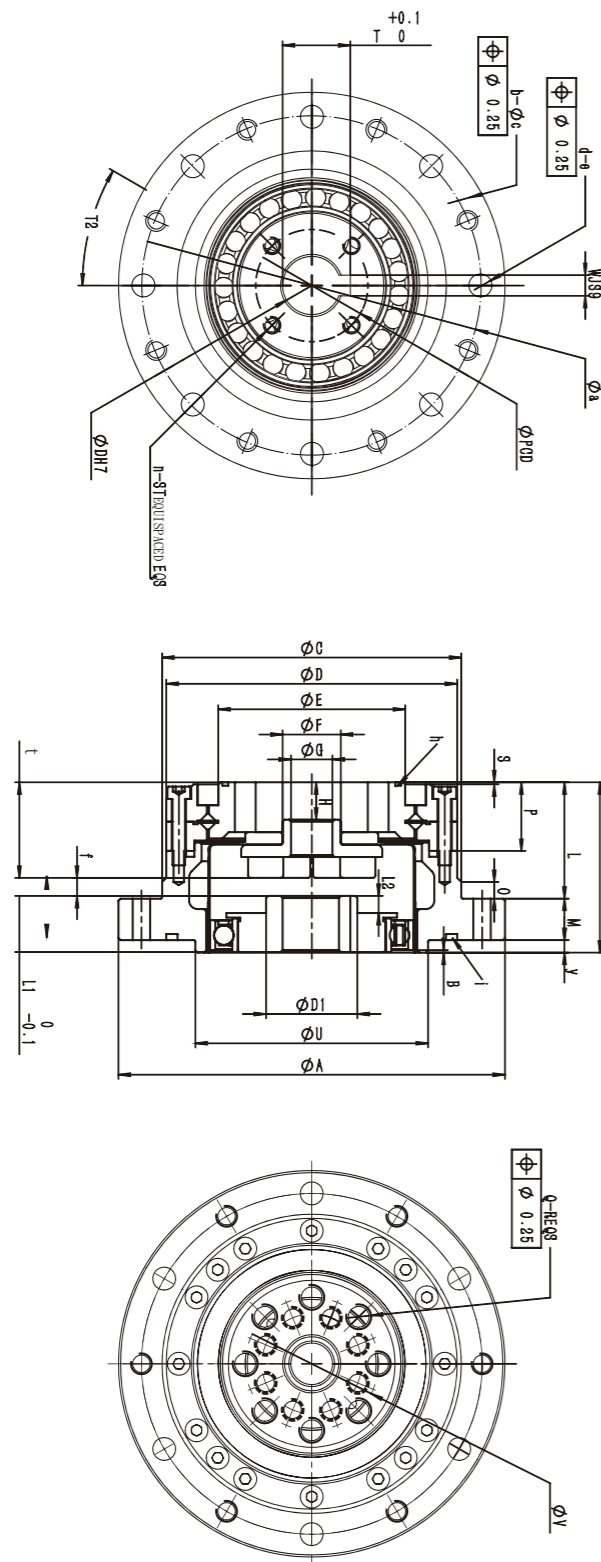

Model 14, 17 only 2 M screw holes

WCSG-I Series Dimension

Symbol	Model	14	17	20	25	32
Φ A h6		73	79	93	107	138
L1		10	12.5	13.5	14.5	16
φC h7		56	63	72	86	113
ΦD		55	62	70	85	112
ΦE		42.5	49.5	58	73	96
ΦF H7		11	10	14	20	25
ΦG		8	7	10	14.5	20
H		9.4	9.5	9	12	15
I		36	39	41	49	60
B		0.5±0.2	0.6±0.2	0.6±0.2	0.7±0.2	0.9±0.2
ΦD1		14	16	20	22	30
L		27	29	28	36	45
M		7	8	10	10	12
Y		2	2	3	3	3
O		3.5	3.5	4	4.5	4.5
P		16.5	16.5	16.5	18.5	22.5
S		0.5	0.5	0.5	0.5	1
Φdh7		6	8	11	14	14
φU H7		38	48	56	67	90
Φv		23	27	32	42	55
Q		6	6	8	8	8
R		M4×8	M5×10	M6×9	M8×12	M10×15
T		7	9.4	12.8	16.3	16.3
WJS9		2	3	4	5	5
φa		65	71	82	96	125
b		8	8	8	10	12
c		4.5	4.5	5.5	5.5	6.6
d		8	8	8	10	12
e		M4	M4	M5	M5	M5
h		29.5x0.5	34.5x0.5	40.64x1.14	53.3x1	70.5x2
i		49.5x2	55.5x2	66.5x2	79.5x2	104.5x2
f		4.2	2.4	4.4	6.5	6.3
t		21.4	23.5	23	26	35.2
T2		30°	30°	30°	22.5°	15°
L2		2.9	4.9	4.1	5.4	4.1
n		2	2	4	4	4
ST		M4	M4	M4	M5	M5
PCD		18	22	25	32	36
Weight(Kg)		0.51	0.66	0.95	1.48	3.18

WCSG-14-XXX-I

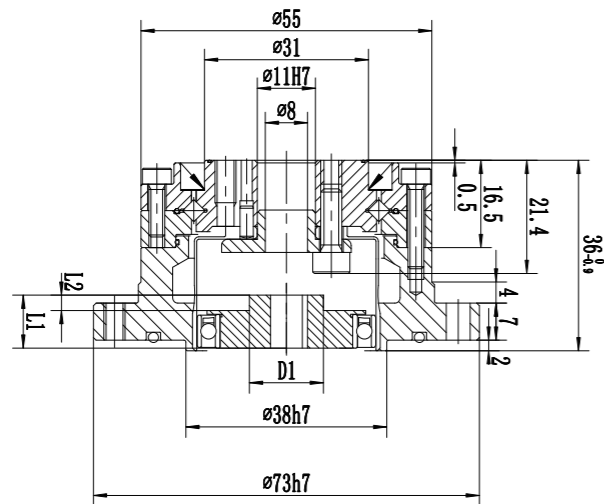
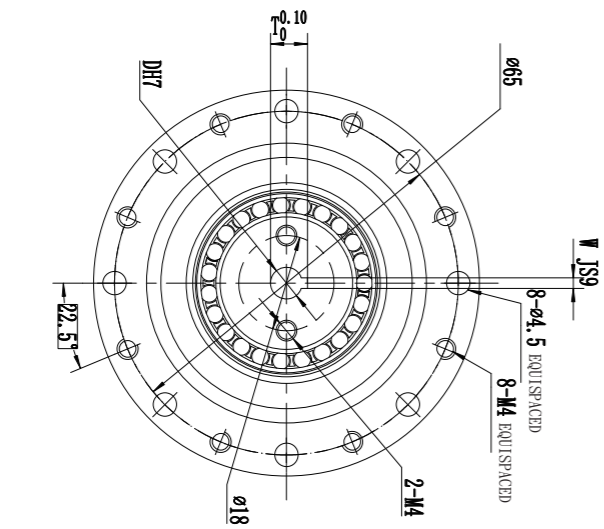

L1	L2	D1	D	T	W
10	2.9	14	6	7	2
8	9.4	3			

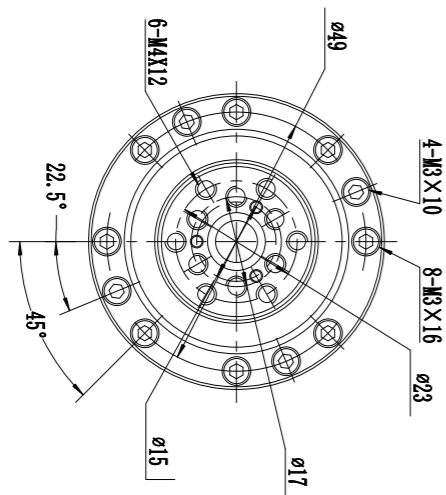

WCSG-17-XXX-I

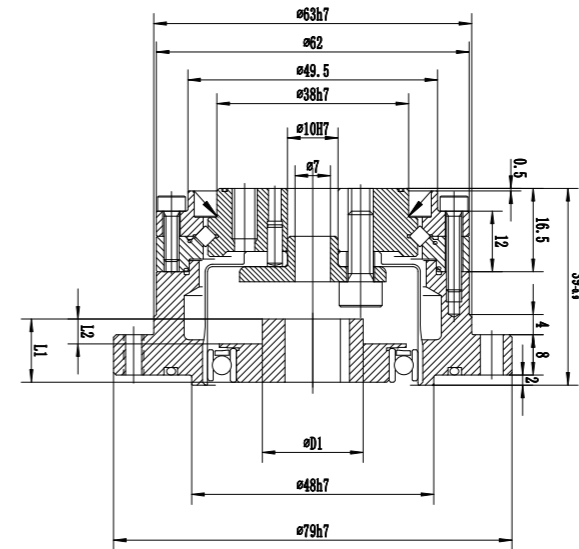
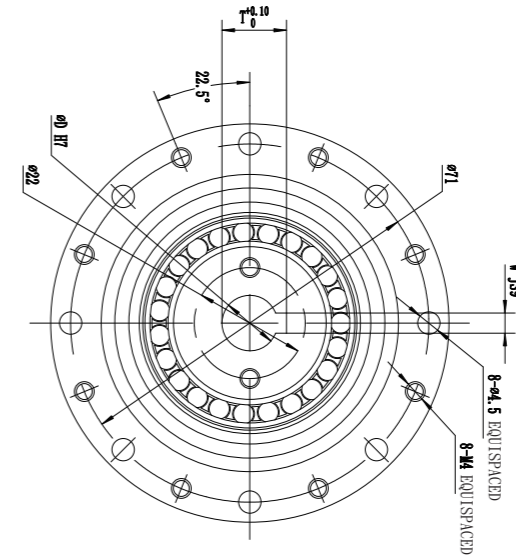

L1	L2	D1	D	T	W
12	54.9	20	11	12.8	4
22	14	16.3	5		

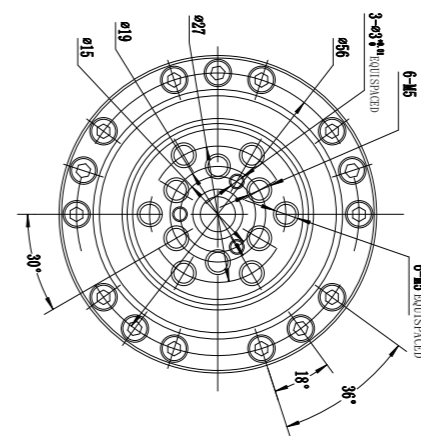

WCSG-20-XXX-I

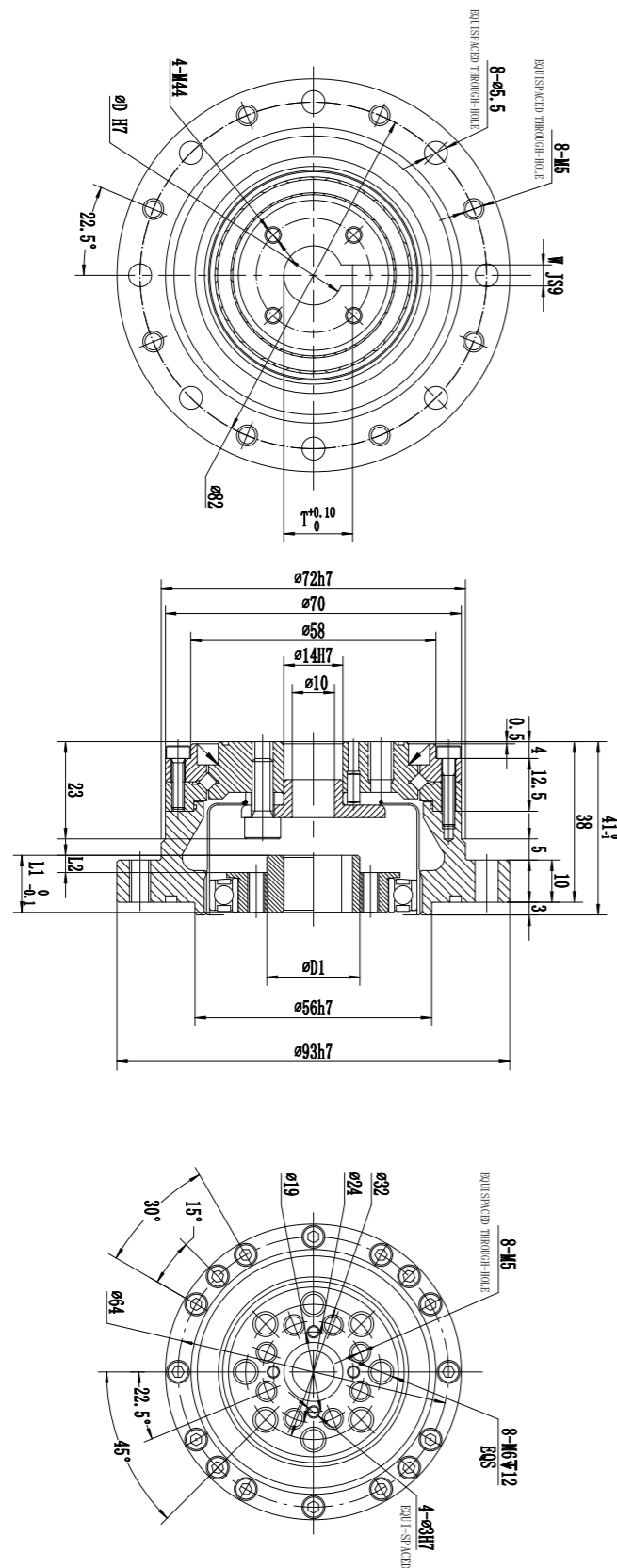

L1	L2	D1	D	T	W
13.5	4.1	20	11	12.8	4
22	14	16.3	5		

WCSG-25-XXX-I

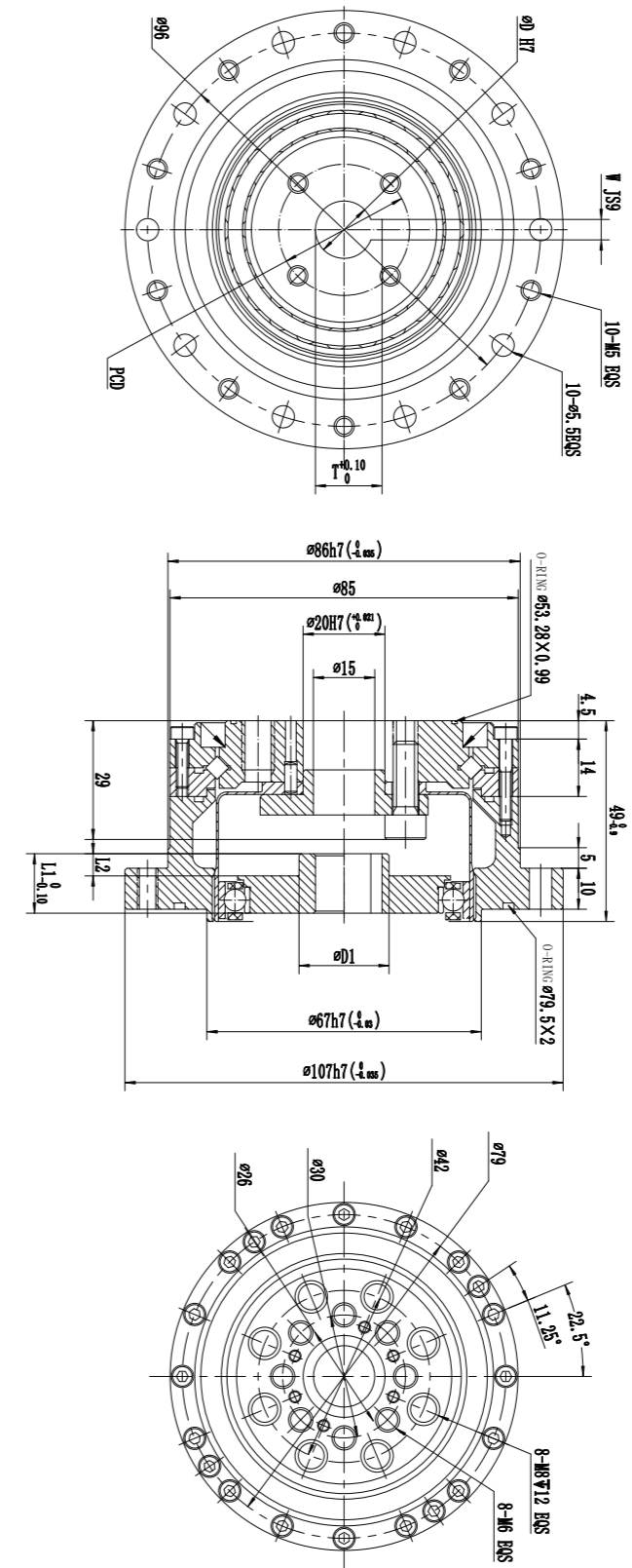

L1	L2	D1	D	T	W	PCD
14.5	5.4	22	11	12.8	4	32
30	19	21.8	6			36

WCSG-32-XXX-I

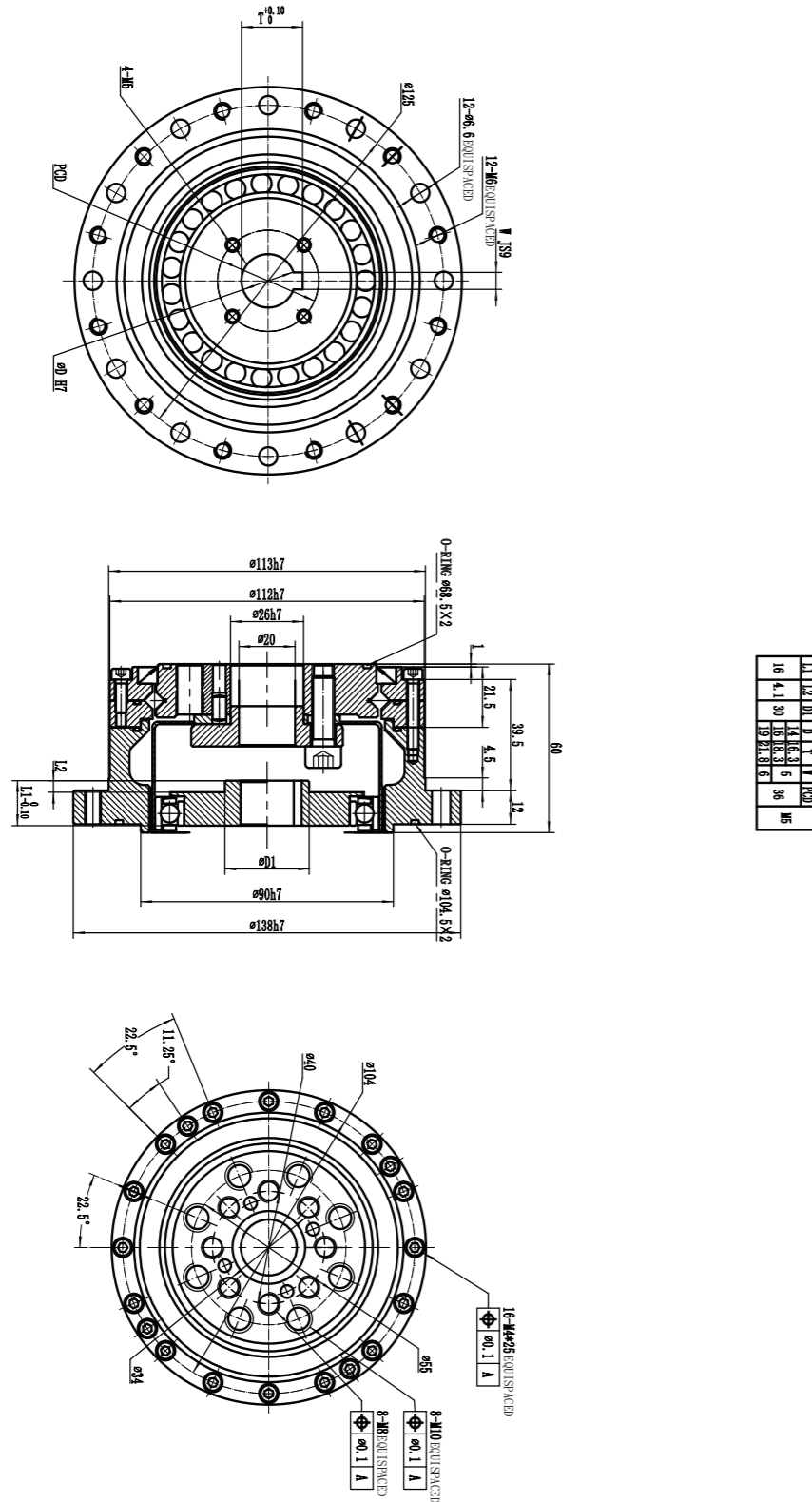

16	1.1	1.2	1.3	1.4	1.5	1.6	1.7	1.8	1.9	2.0
16	4.1	3.0	1.6	6.3	5	36				
										MS

WCSG-II Series Reducer

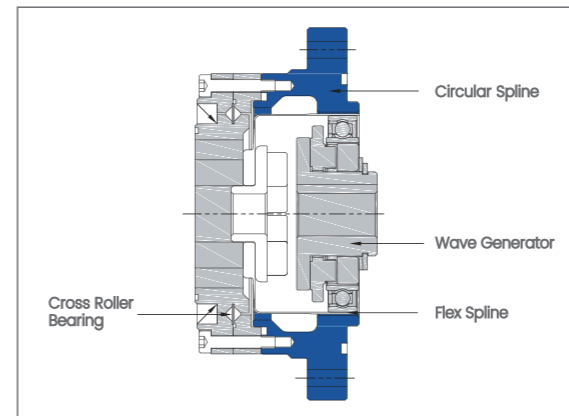
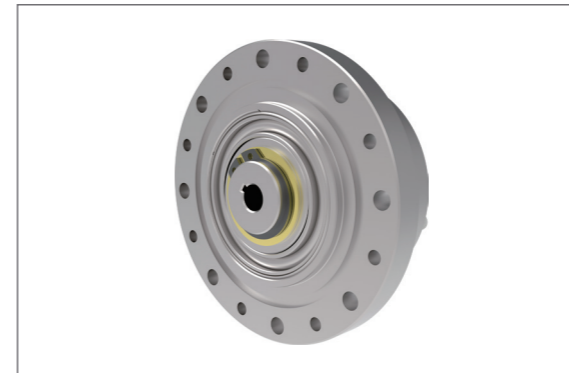

WCSG-II series reducer

WCSG-II series flex Spline is a cup-shaped standard structure. The input shaft is connected with the inner hole of the wave generator through the cross-slider coupling. Generally, the circular spline end is fixed and the flex Spline is the output end.

WCSG-II Series Features

- 1.WCSG series: high torque
- 2.Torque capacity is 30% higher than WCSF series
3. Service life is 43% longer than WCSF series
- 3.Cup-shaped standard structure
4. Compact and simple design
5. No backlash, input- output coaxial
6. High positioning and rotation accuracy

WCSG-II Series Performance Parameter

Model	Ratio	Rated torque at input speed 2000r/min N*m	Allowable maximum torque at start and stop N*m	Maximum allowable load torque N*m	Instantaneous Maximum torque N*m	Maximum allowable input speed r/min	Allowable average input speed r/min	Backlash arc sec	Life Span hrs
14	50	6.3	21	8	42	8000	3500	20	10000
	80	9	27	13	55			20	15000
	100	9	33	13	63			15	15000
17	50	19	40	31	82	7000	3500	20	10000
	80	26	50	32	102			20	15000
	100	28	63	46	129			15	15000
20	50	30	66	40	115	6000	3500	20	10000
	80	40	87	55	149			20	15000
	100	47	97	58	172			15	15000
	120	47	102	58	172			15	15000
25	50	46	114	65	218	5500	3500	20	10000
	80	74	160	102	299			20	15000
	100	78	184	126	332			15	15000
	120	78	196	126	356			15	15000
32	50	89	253	126	448	4500	3500	20	10000
	80	138	356	196	665			15	15000
	100	160	370	253	757			15	15000
	120	160	413	253	803			15	15000

WCSG-II Series Dimensional Drawing

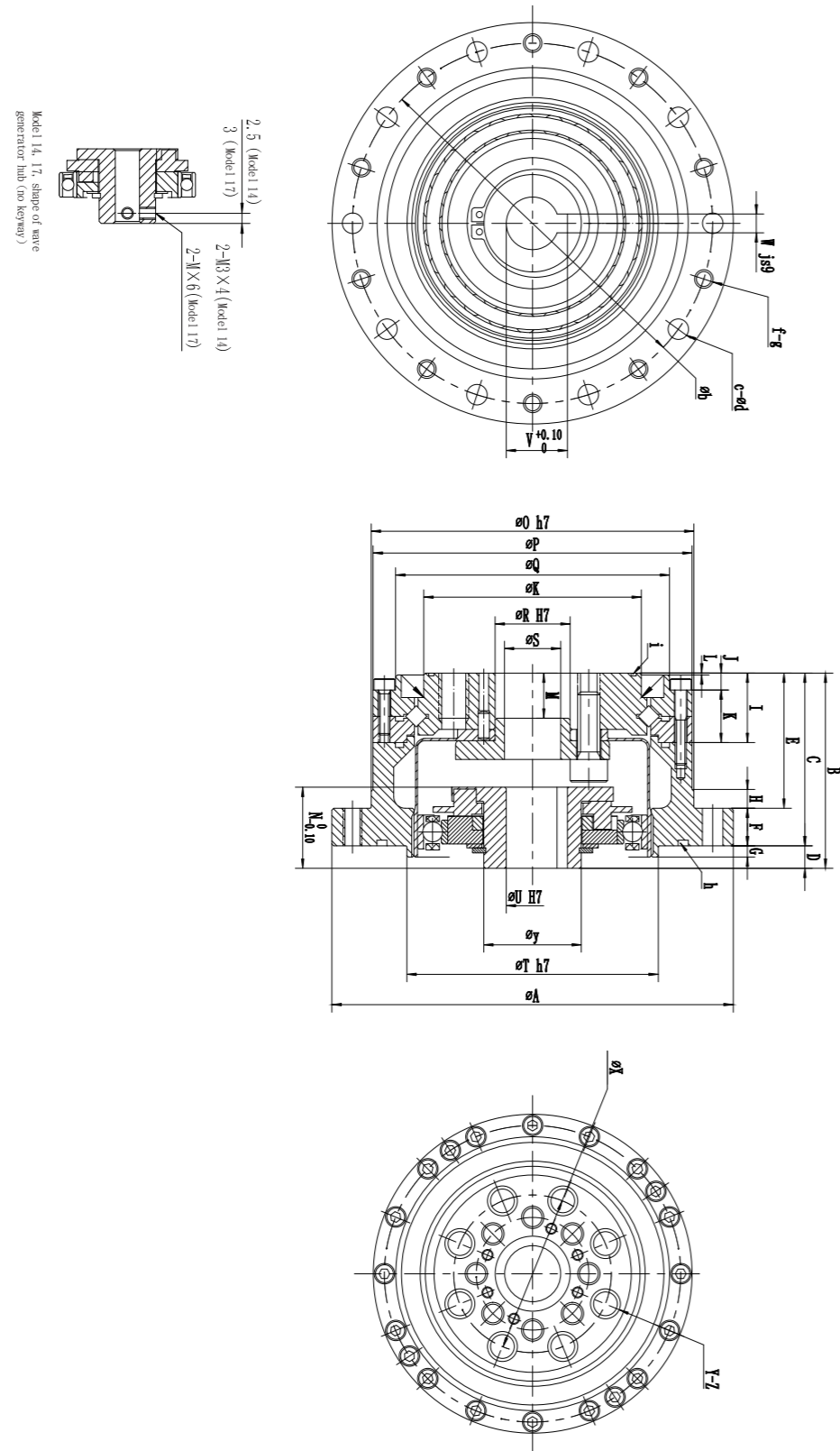

WCSG-II Series Dimension

Symbol \ Model	14	17	20	25	32
φA	73	79	93	107	138
B*	41 ^{-0.9}	45 ^{-0.9}	45.5 ^{-1.0}	52 ^{-1.0}	62 ^{-1.1}
C	34	37	38	46	57
D	7 ^{-0.4}	8 ^{-0.4}	7.5 ^{-0.4}	6 ^{-0.5}	5 ^{-0.8}
E	27	29	28	36	45
F	7	8	10	10	12
G	2	2	3	3	3
H	3.5	4	5	5	5
I	16.5	16.5	16.5	18.5	22.5
J	4.5	4.5	4	4.5	5.5
K	12	12	12.5	14	17
L	0.5	0.5	0.5	0.5	1
M	9.4	9.5	9	12	15
N	18.5	20.7	21.5	21.6	23.6
φO h7	56	63	72	86	113
φP	55	62	70	85	112
φQ	42.5	49.5	58	73	96
φR H7	11	10	14	20	26
φS	6	7	10	15	20
φT h7	38	48	56	67(68)	90
φU H7	6	8	12	14	14
V	7	9.4	13.8 ^{+0.1}	16.3 ^{+0.1}	16.3 ^{+0.1}
W js9	2	3	4	5	5
X	23	27	32	42	55
Y	6	6	8	8	8
Z	M4*8	M5*10	M6*9	M8*12	M10*15
a	1.1	0.8	1	1.4	1.4
φb	65	71	82	96	125
c	8	8	8	10	12
φd	4.5	4.5	5.5	5.5	6.6
g	M4	M4	M5	M5	M6
f	8	8	8	10	12
h	29*0.5	34.5*0.8	40.5*1.0	53*1.0	S71
i	S50	S56	S67	S80	S105
φk	31	38	45	58	78
φy	14	18	21	26	26
Weight (Kg)	0.52	0.68	0.98	1.5	3.2

WCSG-14-XXX-II

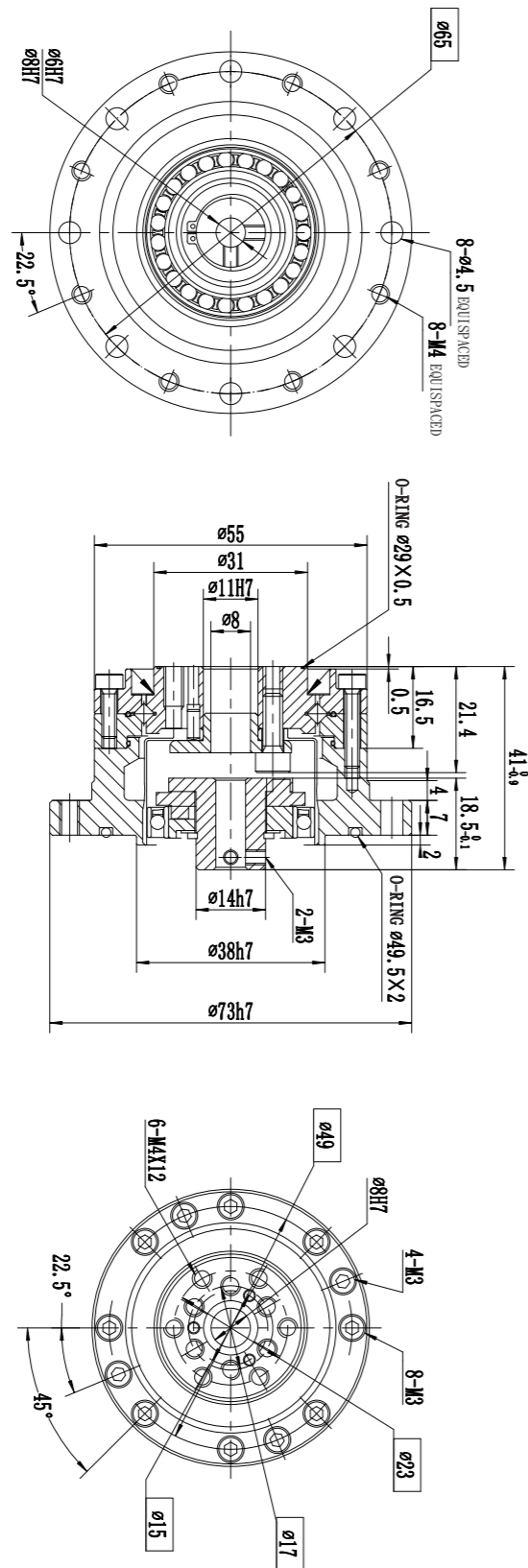

WCSG-17-XXX-II

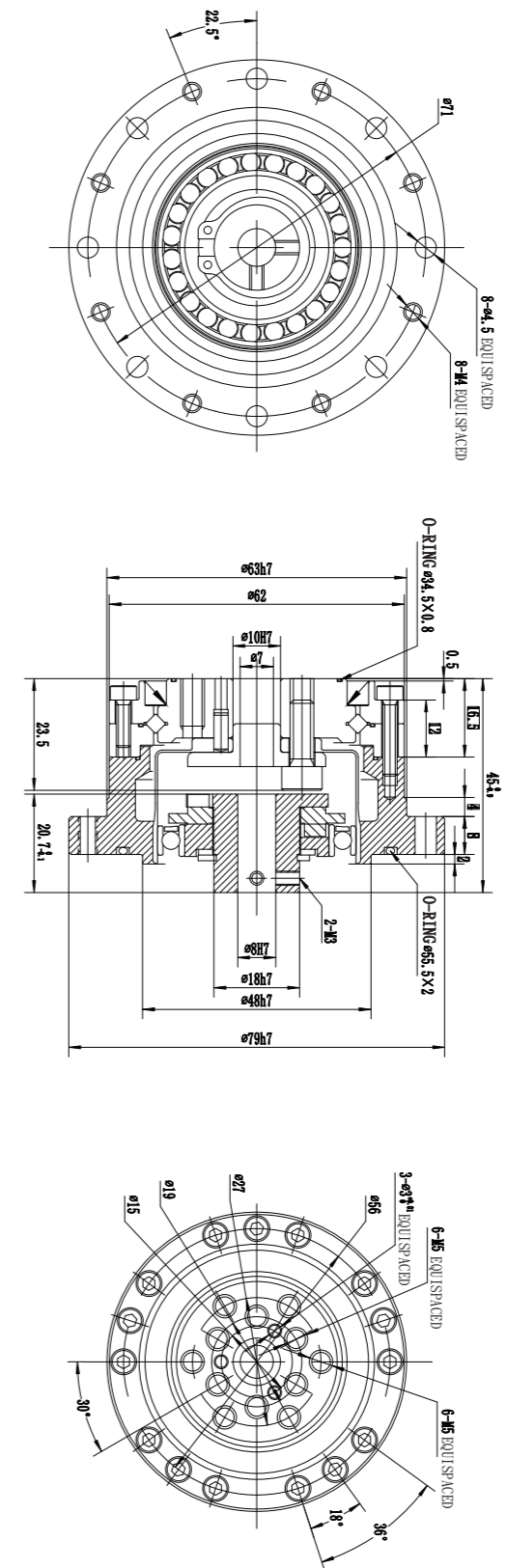

WCSG-20-XXX-II

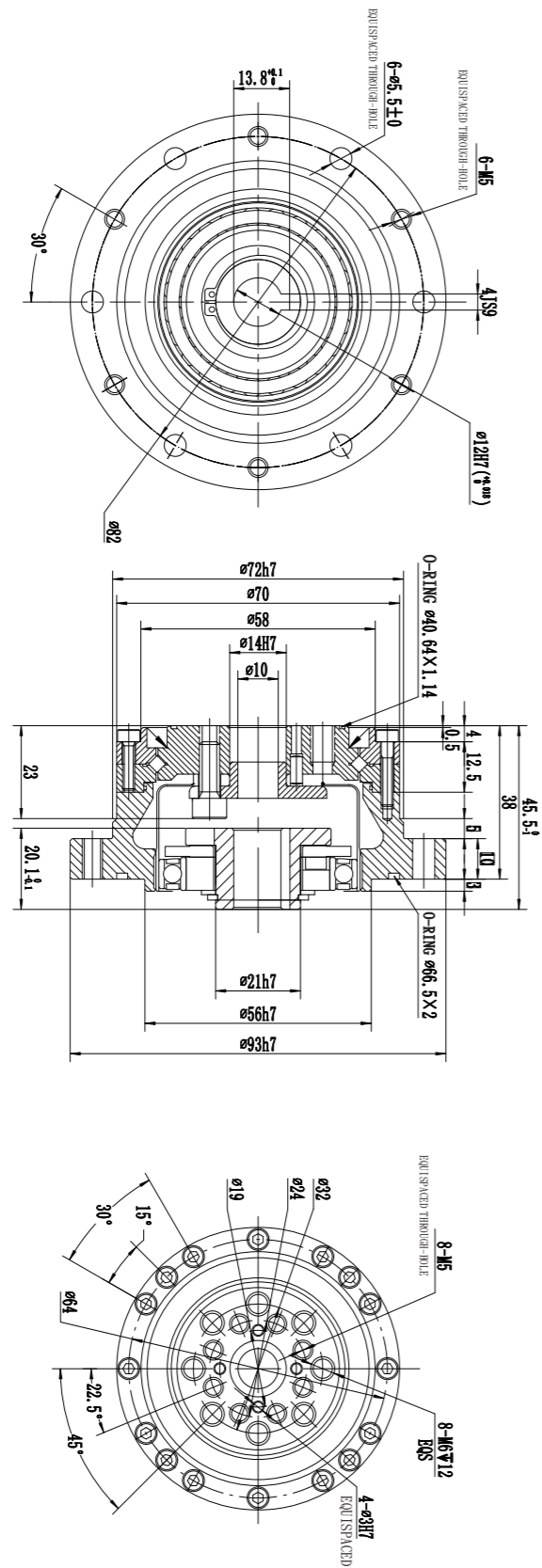

WCSG-25-XXX-II

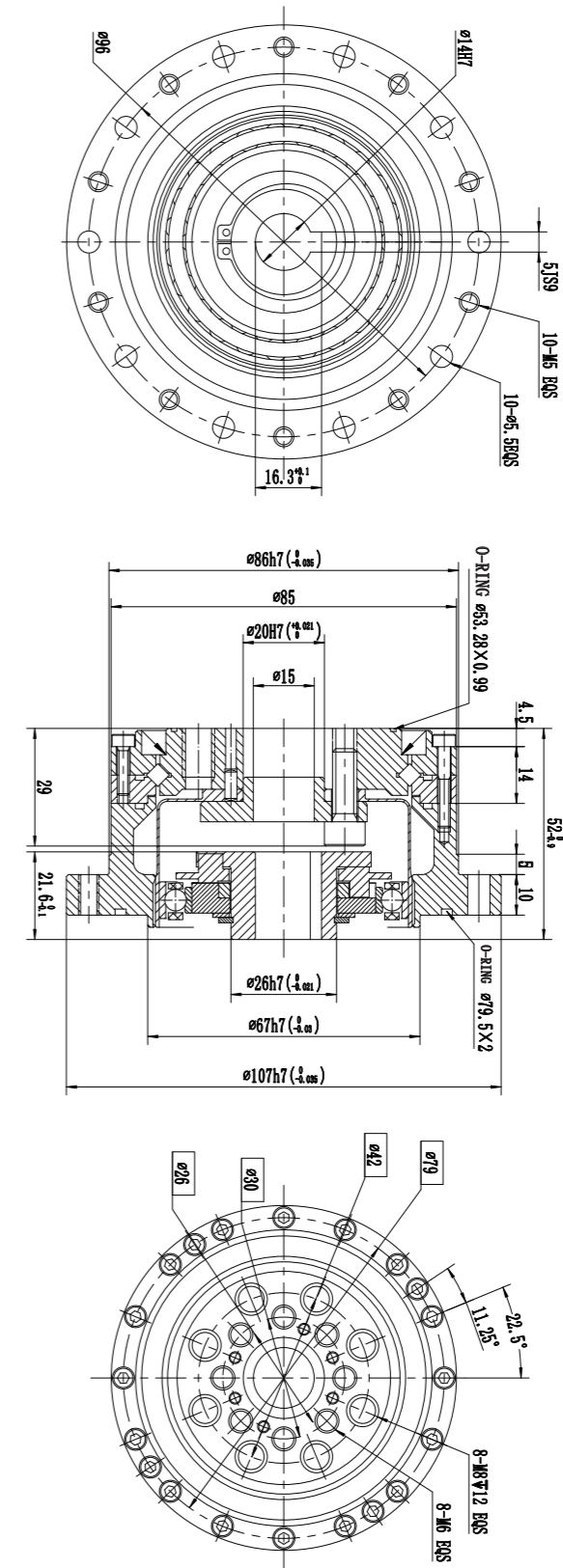

WCSG-32-XXX-II

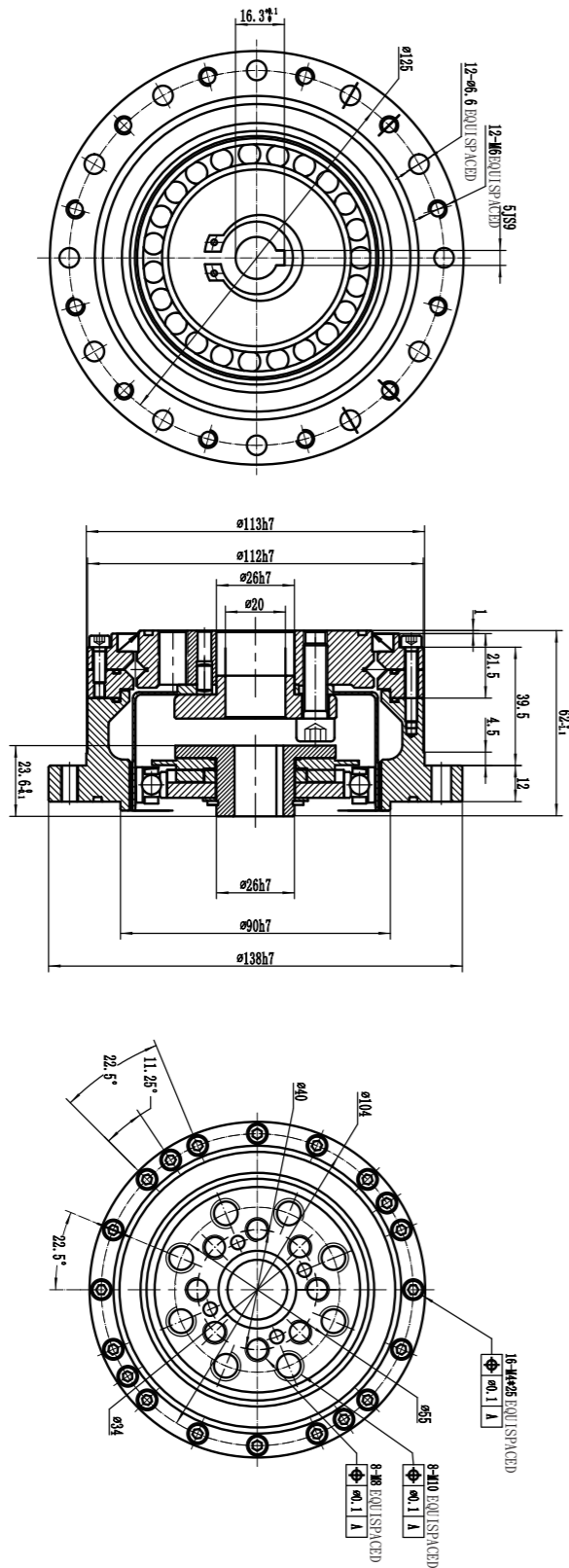

WSHG-I Series Reducer

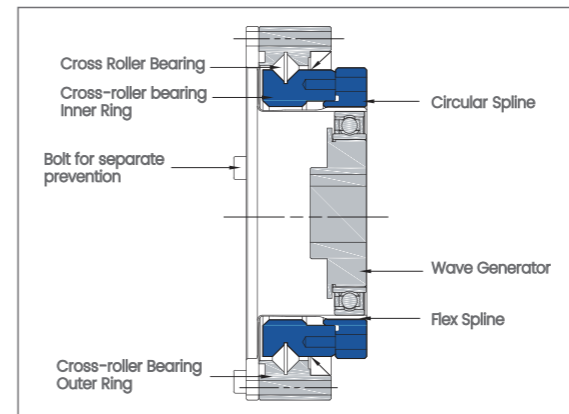

WSHG-I series reducer

WSHG-I series flex Spline is middle flanged standard structure, whole reducer compact design. The input shaft is connected with the inner hole of the wave generator through the cross-slider coupling coil. It can be used in both connection ways: one is fixed circular spline end and flex spline output, the other is fixed flex spline and circular spline output.

WSHG-I Series Features

1. Flat Shape, one-piece CAM structure
2. Compact, simple design
3. No backlash
4. Input-output coaxial
5. Excellent positioning and rotation accuracy

WSHG-I Series Performance Parameter

Model	Ratio	Rated torque at input speed 2000r/min N*m	Allowable maximum torque at start and stop N*m	Maximum allowable load torque N*m	Instantaneous Maximum torque N*m	Maximum allowable input speed r/min	Allowable average input speed r/min	Backlash arc sec	Life Span hrs
14	50	6.3	21	8	42	8000	3500	20	10000
	80	9	27	13	55			20	15000
	100	9	33	13	63			15	15000
17	50	19	40	31	82	7000	3500	20	10000
	80	26	50	32	102			20	15000
	100	28	63	46	129			15	15000
20	50	30	66	40	115	6000	3500	20	10000
	80	40	87	55	149			20	15000
	100	47	97	58	172			15	15000
	120	47	102	58	172			15	15000
25	50	46	114	65	218	5500	3500	20	10000
	80	74	160	102	299			20	15000
	100	78	184	126	332			15	15000
	120	78	196	126	356			15	15000
32	50	89	253	126	448	4500	3500	20	10000
	80	138	356	196	665			15	15000
	100	160	370	253	757			15	15000
	120	160	413	253	803			15	15000

WSHG-I Series Dimensional Drawing

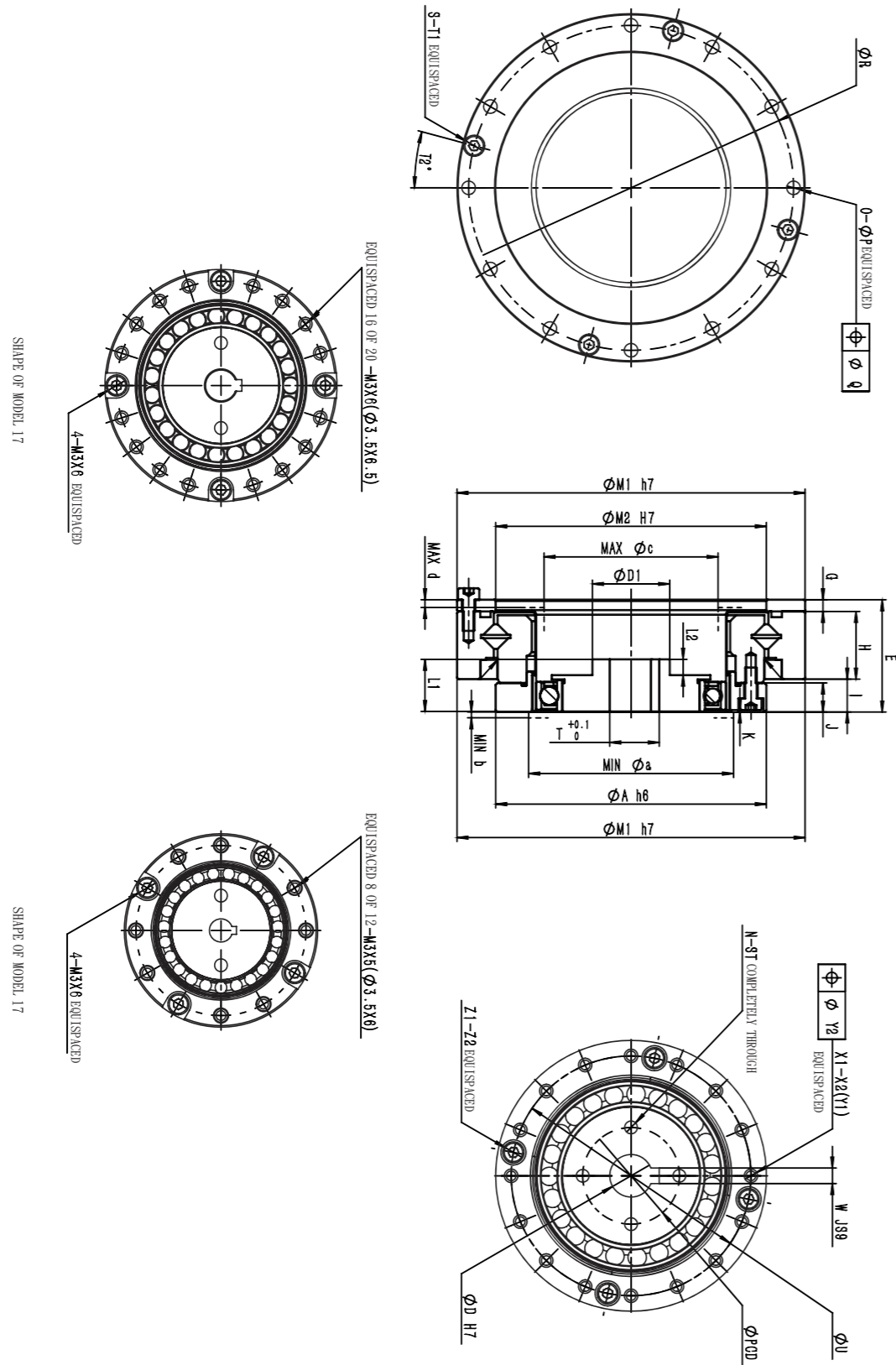

WSHG-I Series Dimension

Model	14	17	20	25	32
ΦA h6	50	60	70	85	110
ΦD	6 8	8 11 14	11 12 14	11 14 19	14 16 19
L1	10	12.5	13.5	14.5	16
L2	2.9	4.9	4.1	5.4	4.1
D1	14	16 20 22	20 22 22	22 22 30	30
T	7 9.4	9.4 12.8 16.3	12.8 13.8 16.3	12.8 16.3 21.8	16.3 18.3 21.8
W	2 3	3 4 5	4 5 5	4 5 6	5 6 6
PCD	18	22	25 27 27	32 36 36	36
N	2	2	4	4	4
ST	M4	M4	M4	M5	M5
E	23.5	26.5	29	34	42
G	2.4	3	3	3.3	3.6
H	14.1	16	17.5	18.7	23.4
I	7	7.5	8.5	12	15
J	6	6.5	7.5	10	14
K	0.5±0.2	0.6±0.2	0.6±0.2	0.7±0.2	0.9±0.2
φM1 h7	70	80	90	110	142
φM2 h7	48	60	70	88	114
O	8	12	12	12	12
φP	3.5	3.5	3.5	4.5	5.5
φQ	0.25	0.25	0.25	0.25	0.25
φR	64	74	84	102	132
S	2	4	4	4	4
T1	M3×6	M3×6	M3×8	M3×8	M4×8
T2	22.5°	15°	15°	15°	15°
φU	44	54	62	77	100
X1	see attached drawing	see attached drawing	16	16	16
X2	M3×5	M3×6	M3X6	M4X7	M5X8
Y1	Φ3.5×6	Φ3.5×6.5	Φ3.5×7.5	Φ4.5×10	Φ5.5×14
Y2	0.25	0.25	0.25	0.25	0.25
Z1	4	4	4	4	4
Z2	M3×6	M3×6	M3×8	M3×10	M4×16
φa	38	45	53	66	86
b	1	1	1.5	1.5	1.5
φc	31	38	45	56	73
d	1.7	2.1	2	2	2
Weight(Kg)	0.4	0.57	0.78	1.29	2.92

WSHG-14-XXX-I

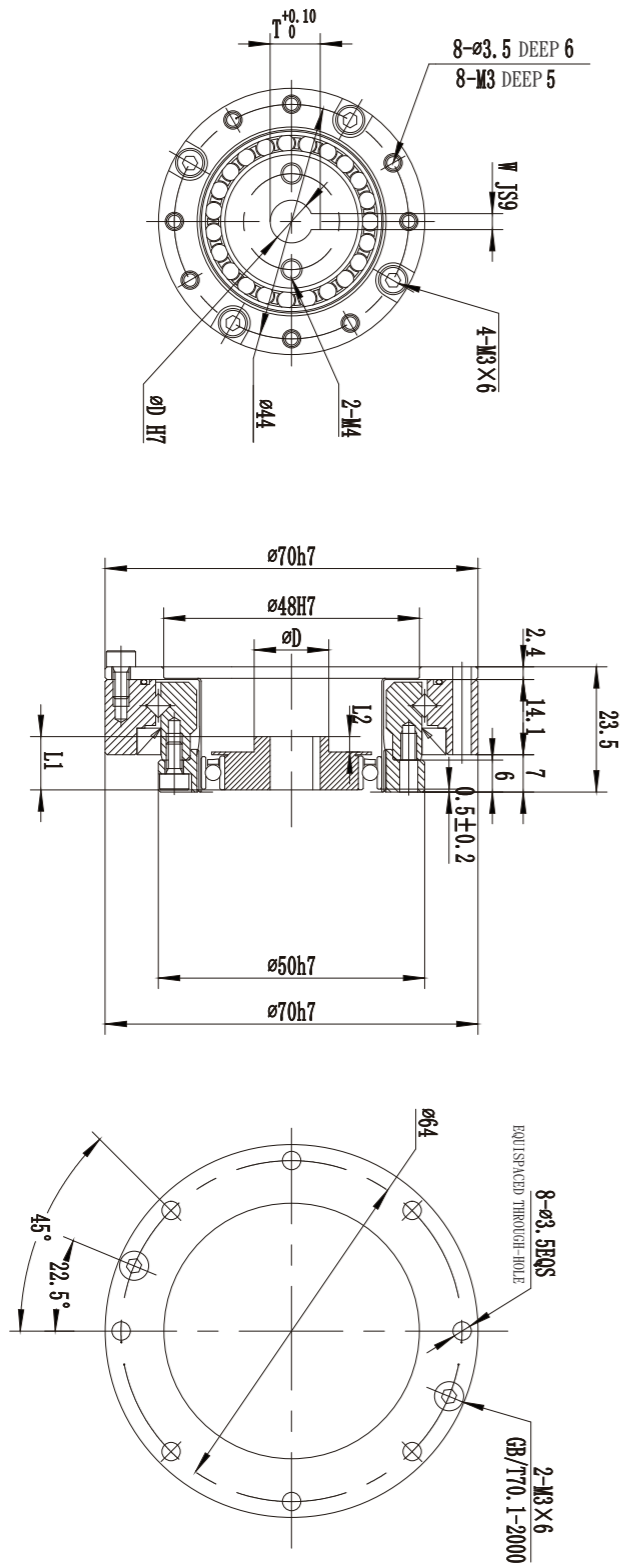

L1	L2	D1	D	T	W	PCD
10	2.9	14	6	7	2	18
			8	9.4	3	

WSHG-17-XXX-I

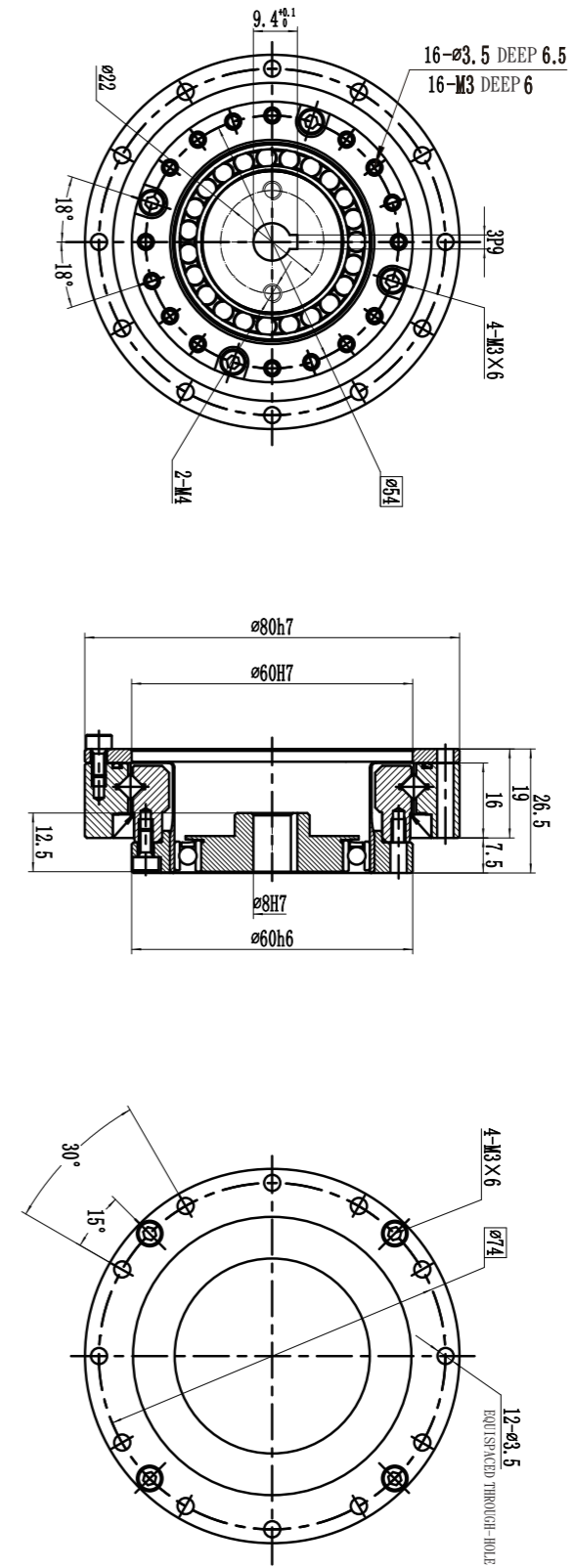

WSHG-20-XXX-I

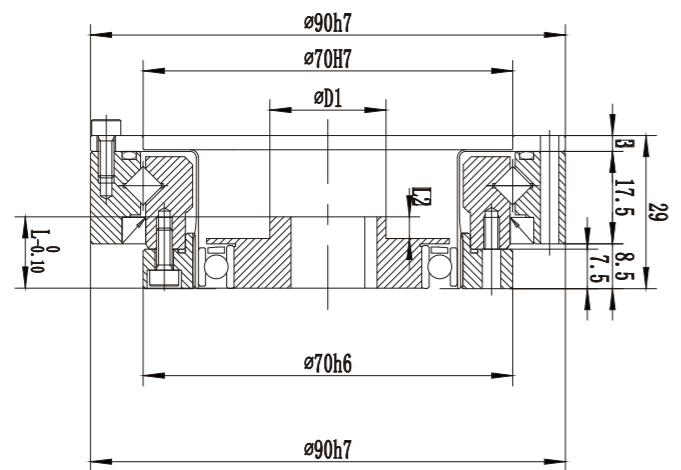
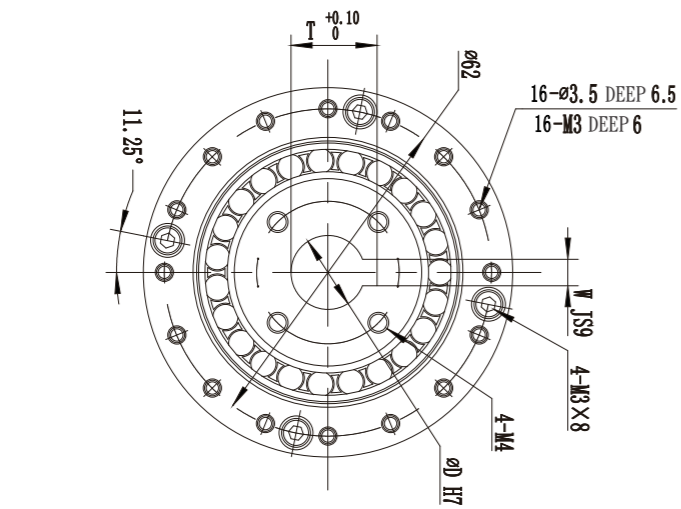

L1	L2	D1	D	T	W	PCD
13.5	4.1	20	11	12.8	4	25
22	14	16.3	5	27		

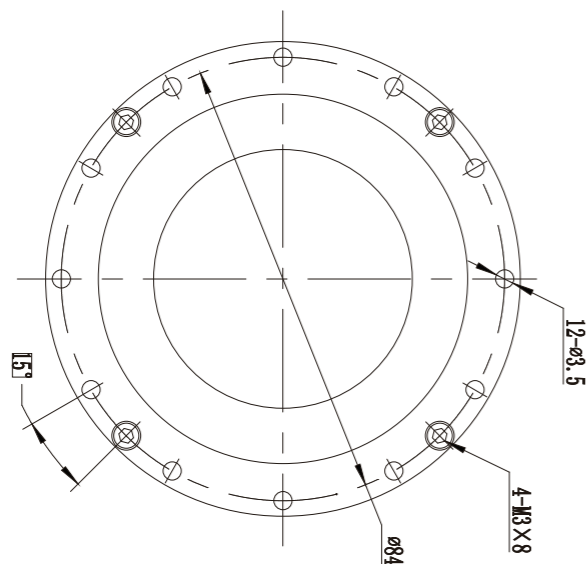

WSHG-25-XXX-I

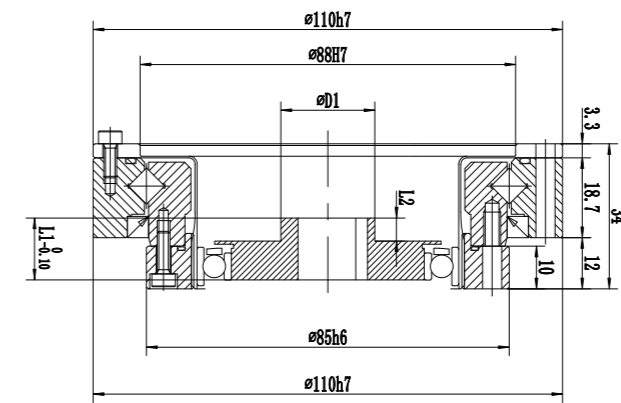
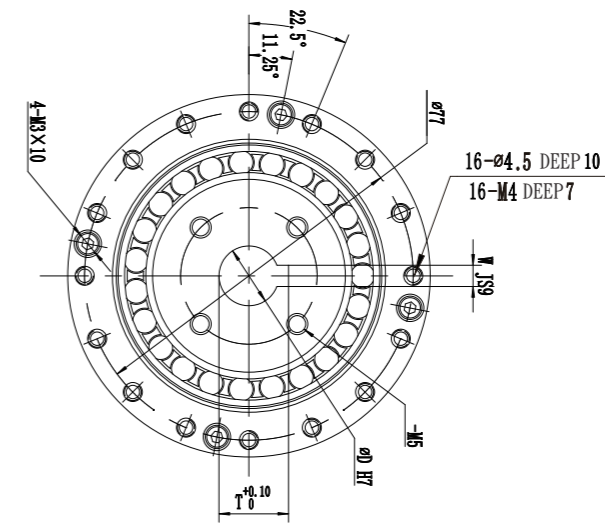

L1	L2	D1	D	T	W	PCD
14.5	5.4	22	11	12.8	4	32
30	19	21.8	6	36		

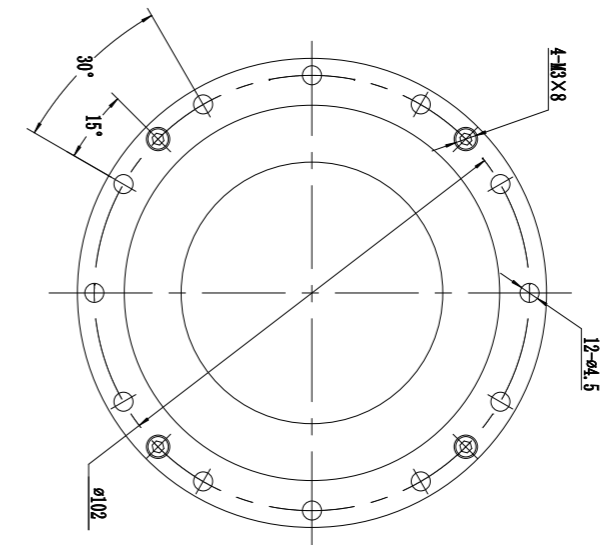

WSHG-32-XXX-I

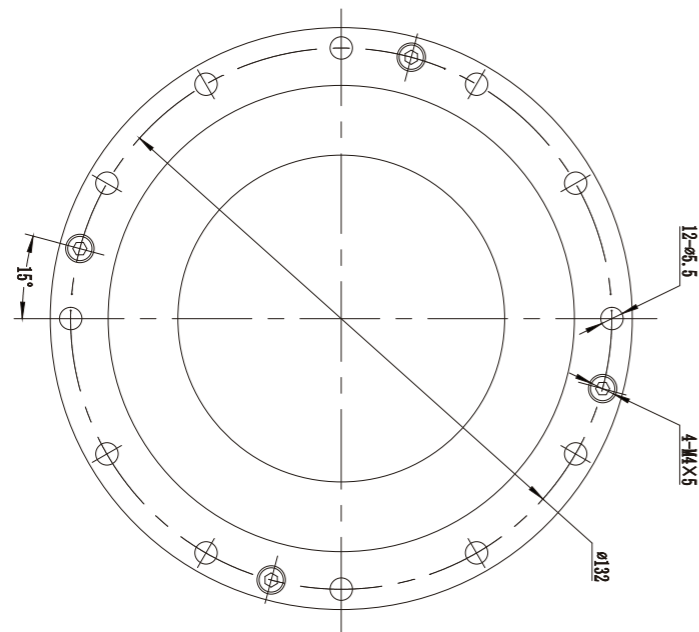
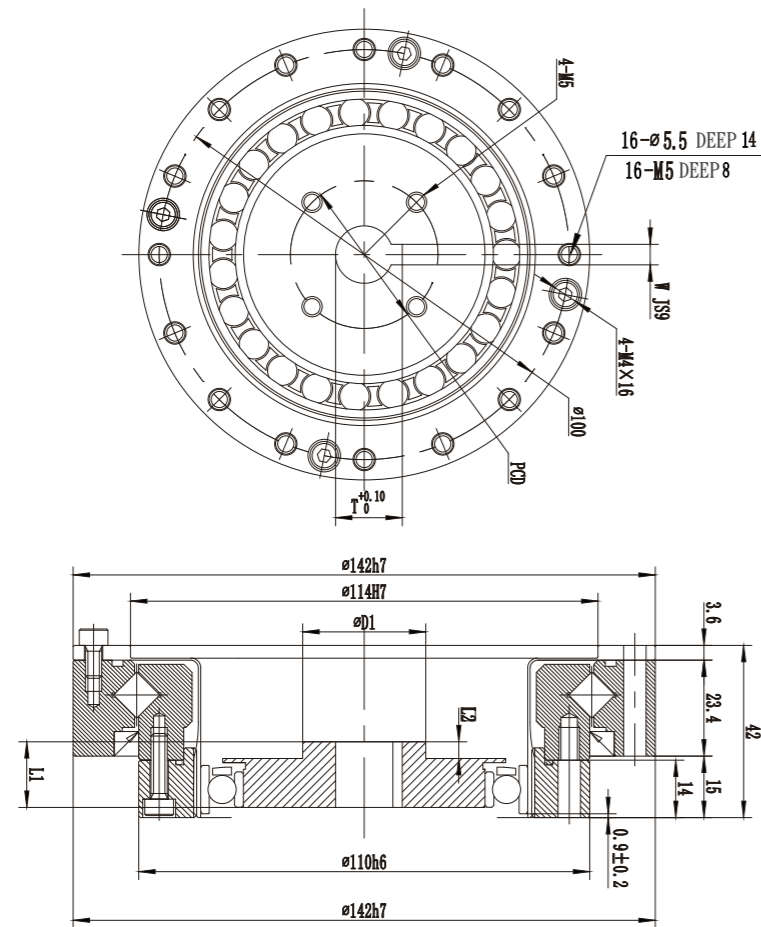

WSHG-II Series Reducer

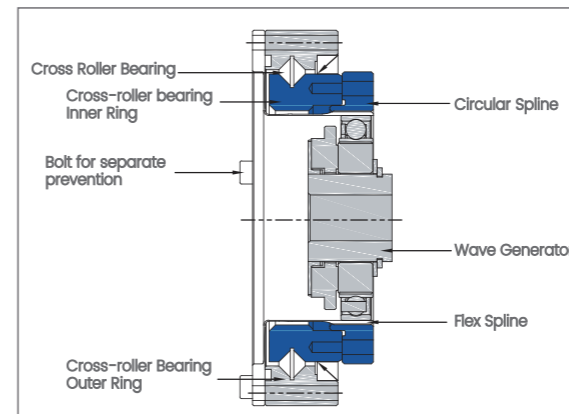

WSHG-II series reducer

WSHG -II Series flex spline is hollow hat type structure, compact structure, input shaft is connected through the cross-sliding coupling and wave generator inner hole, can use by the connection way of fix the circular spline, flex spline output, or fix flex spline end, and circular spline output connection to use.

WSHG-II Series Features

- 1.Flat Shape, one-piece CAM structure
- 2.Compact, simple design
- 3.No backlash
- 4.Input-output coaxial
- 5.Excellent positioning and rotation accuracy

WSHG-II Series Performance Parameter

Model	Ratio	Rated torque at input speed 2000r/min N*m	Allowable maximum torque at start and stop N*m	Maximum allowable load torque N*m	Instantaneous Maximum torque N*m	Maximum allowable input speed r/min	Allowable average input speed r/min	Backlash arc sec	Life Span hrs
14	50	6.3	21	8	42	8000	3500	20	10000
	80	9	27	13	55			20	15000
	100	9	33	13	63			15	15000
17	50	19	40	31	82	7000	3500	20	10000
	80	26	50	32	102			20	15000
	100	28	63	46	129			15	15000
20	50	30	66	40	115	6000	3500	20	10000
	80	40	87	55	149			20	15000
	100	47	97	58	172			15	15000
	120	47	102	58	172			15	15000
25	50	46	114	65	218	5500	3500	20	10000
	80	74	160	102	299			20	15000
	100	78	184	126	332			15	15000
	120	78	196	126	356			15	15000
32	50	89	253	126	448	4500	3500	20	10000
	80	138	356	196	665			15	15000
	100	160	370	253	757			15	15000
	120	160	413	253	803			15	15000

WSHG-II Series Dimensional Drawing

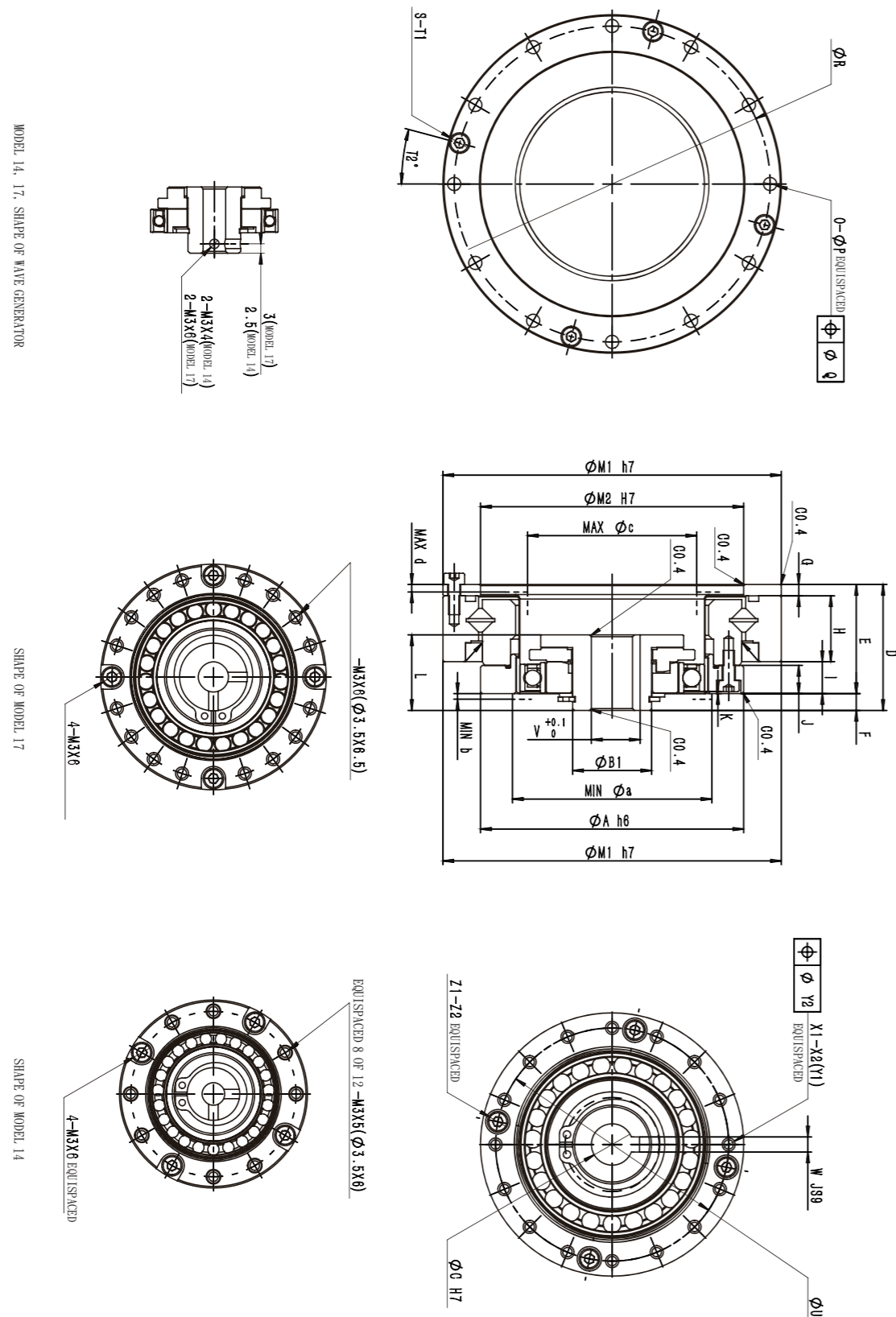

WSHG-II Series Dimension

Symbol	Model	14	17	20	25	32
Φ A h6		50	60	70	85	110
Φ B		14	18	21	26	26
Φ C H7		6	8	9	11	14
D	SHF Series	28.5 ^{-0.8}	32.5 ^{-0.4}	33.5 ^{-1.0}	37 ^{-1.1}	44 ^{-1.1}
	SHG Series	28.5 ^{-0.4}	32.5 ^{-0.4}	33.5 ^{-0.4}	37 ^{-0.5}	44 ^{-0.6}
E		23.5	26.5	29	34	42
F		5	6	4.5	3	2
G		2.4	3	3	3.3	3.6
H		14.1	16	17.5	18.7	23.4
I		7	7.5	8.5	12	15
J		6	6.5	7.5	10	14
K	SHF Series	0.4	0.3	0.1	2.1	2.5
	SHG Series	1.4	1.6	1.5	3.5	4.2
L	SHF Series	17.6 ^{-0.1}	19.5 ^{-0.1}	20.1 ^{-0.1}	20.2 ^{-0.1}	22 ^{-0.1}
	SHG Series	18.5 ^{-0.1}	20.7 ^{-0.1}	21.5 ^{-0.1}	21.6 ^{-0.1}	23.6 ^{-0.1}
Φ M1 h7		70	80	90	110	142
Φ M2 H7		48	60	70	88	114
Φ N		-	-	-	-	-
O		8	12	12	12	12
Φ P		3.5	3.5	3.5	4.5	5.5
Φ Q		0.25	0.25	0.25	0.25	0.25
Φ R		64	74	84	102	132
S		2	4	4	4	4
T1		M3×6	M3×6	M3×8	M3×8	M4×8
T2		22.5°	15°	15°	15°	15°
Φ U		44	54	62	77	100
V		-	-	10.4	12.8	16.3
W JS9		-	-	3	4	5
X1		EQUISPACED 8 OF 12	EQUISPACED 16 OF 20	16	16	16
X2		M3×5	M3×6	M3×6	M4×7	M5×8
Y1		Φ3.5×6	Φ3.5×6.5	Φ3.5×7.5	Φ4.5×10	Φ5.5×14
Y2		0.25	0.25	0.25	0.25	0.25
Z1		4	4	4	4	4
Z2		M3×6	M3×6	M3×8	M3×10	M4×16
a		38	45	53	66	86
b		1	1	1.5	1.5	1.5
Φ c		31	38	45	56	73
d		1.7	2.1	2	2	2
e		D49585	D59685	D69785	D84945	D1101226
Weight(Kg)		0.41	0.57	0.81	1.31	2.94

WSHG-14-XXX-II

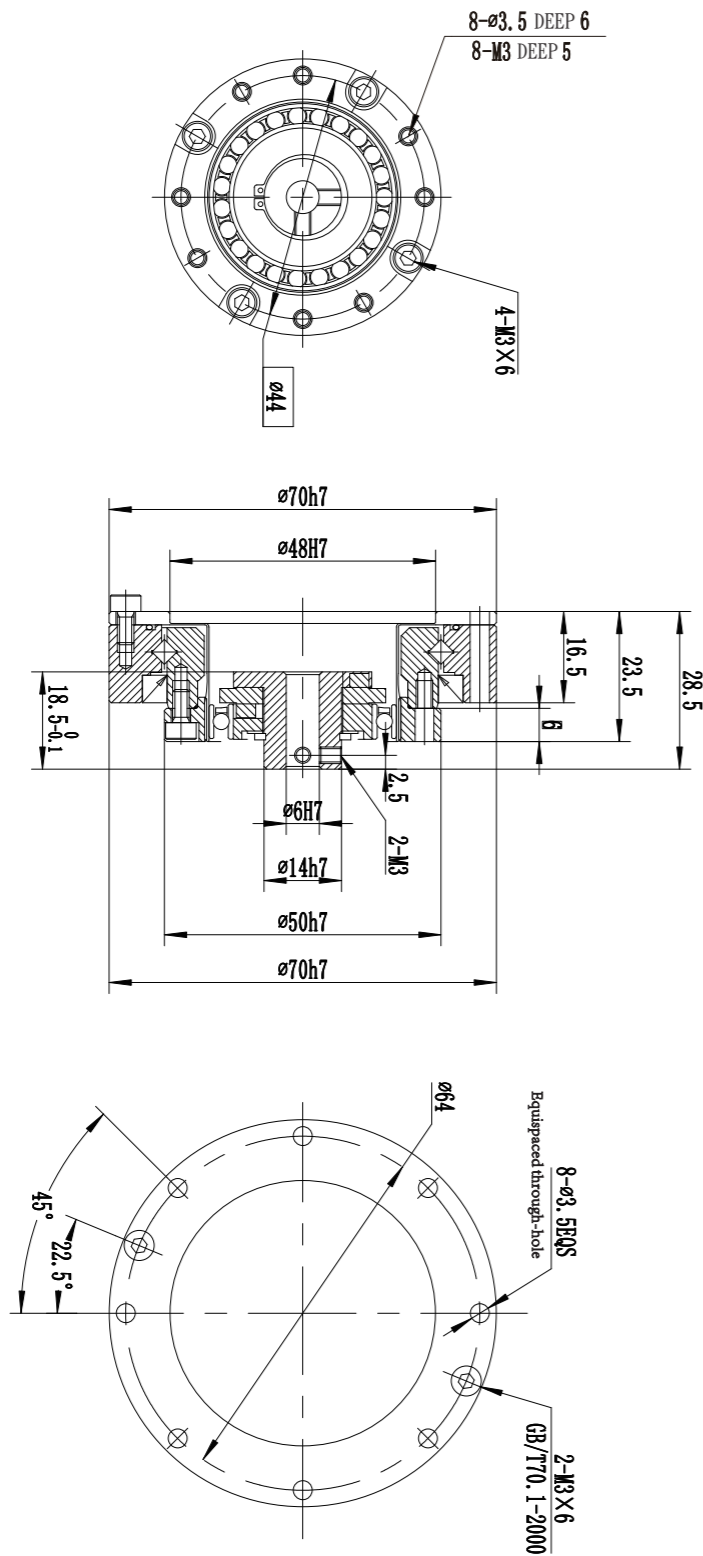

WSHG-17-XXX-II

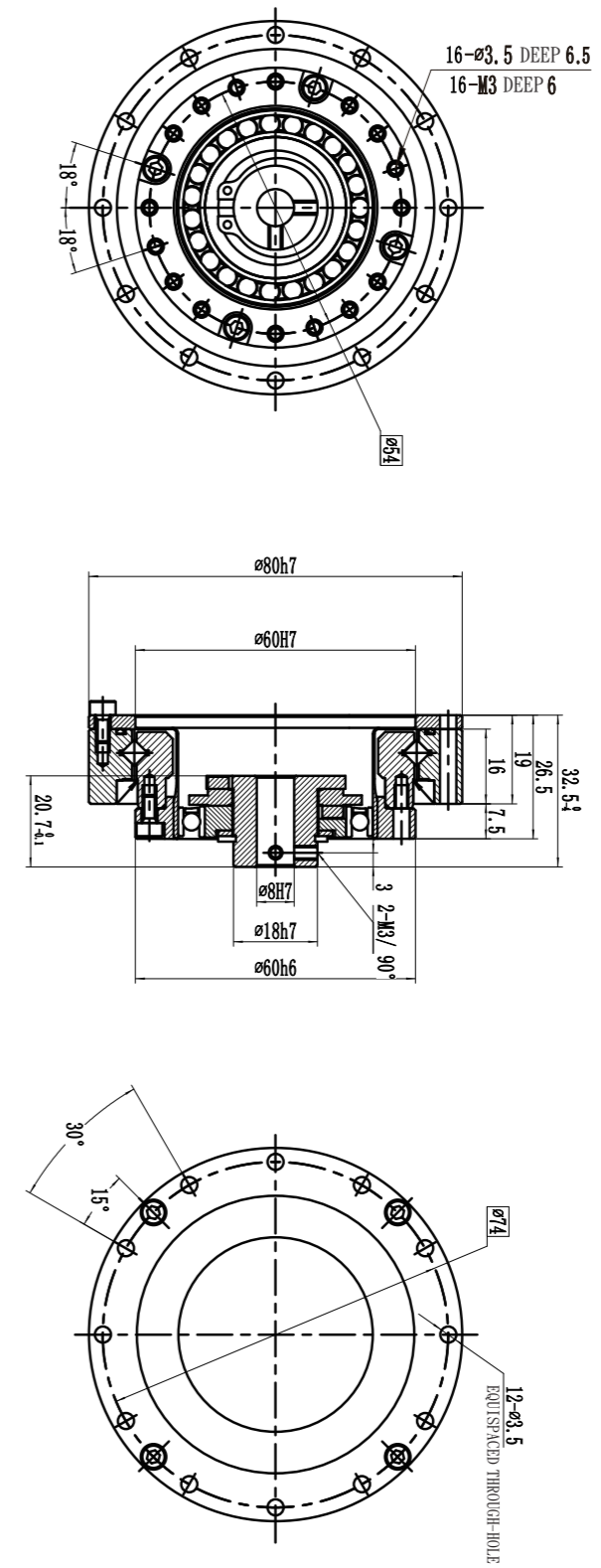

WSHG-20-XXX-II

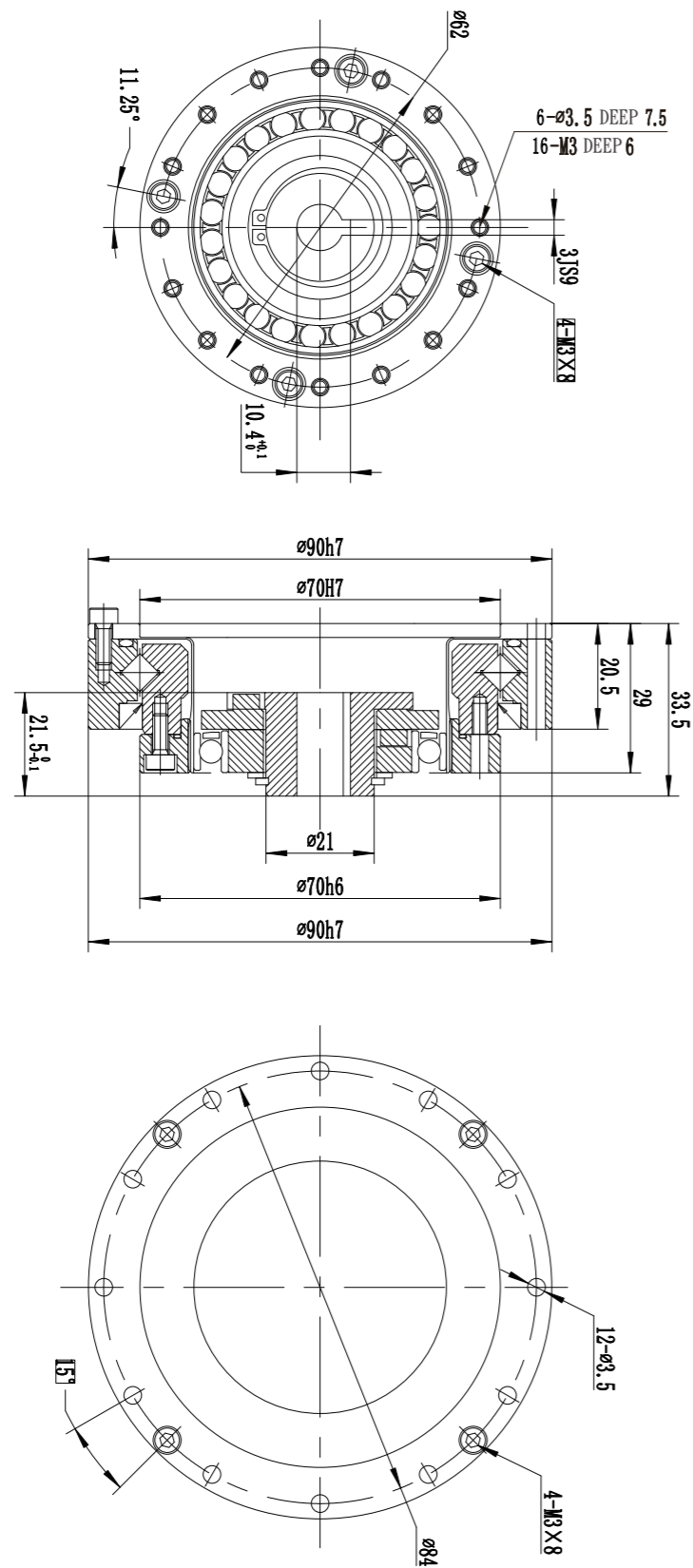

WSHG-25-XXX-II

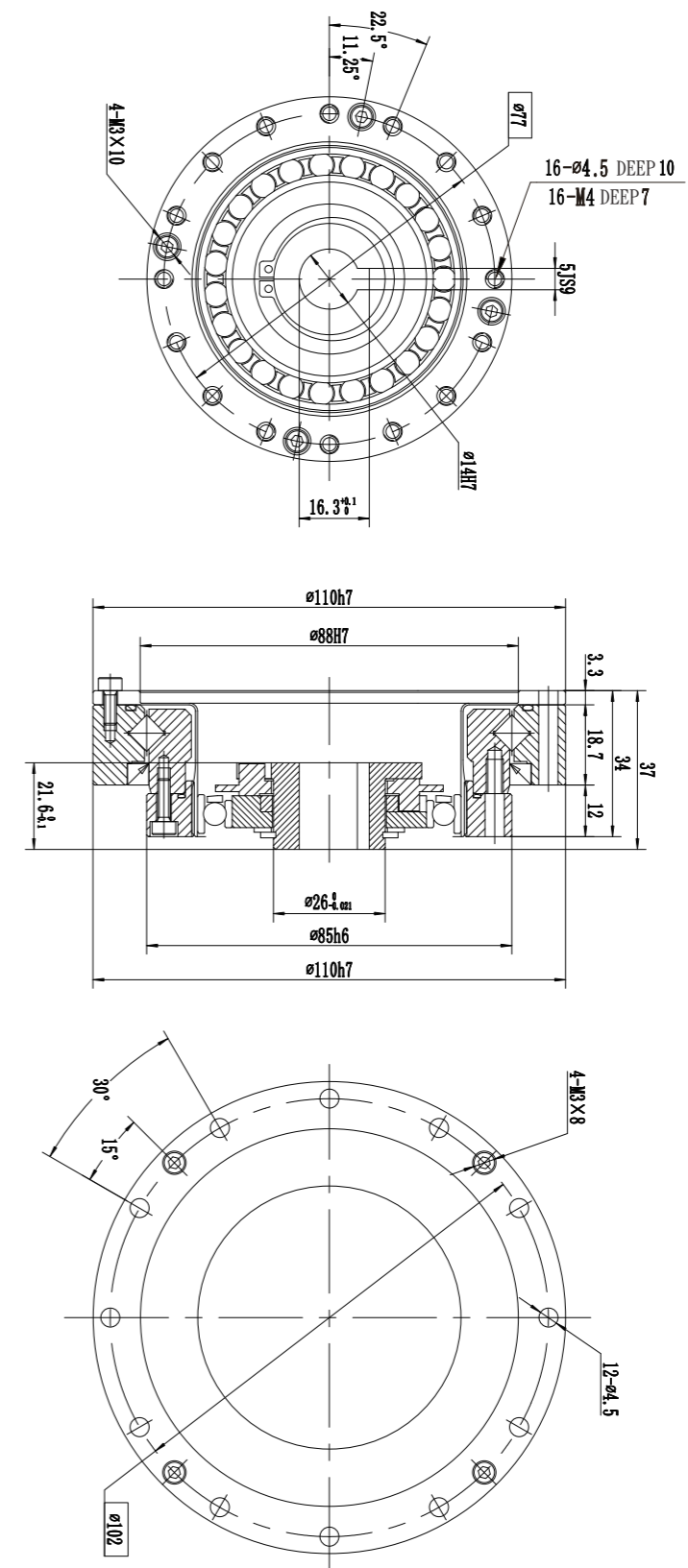

WSHG-32-XXX-II

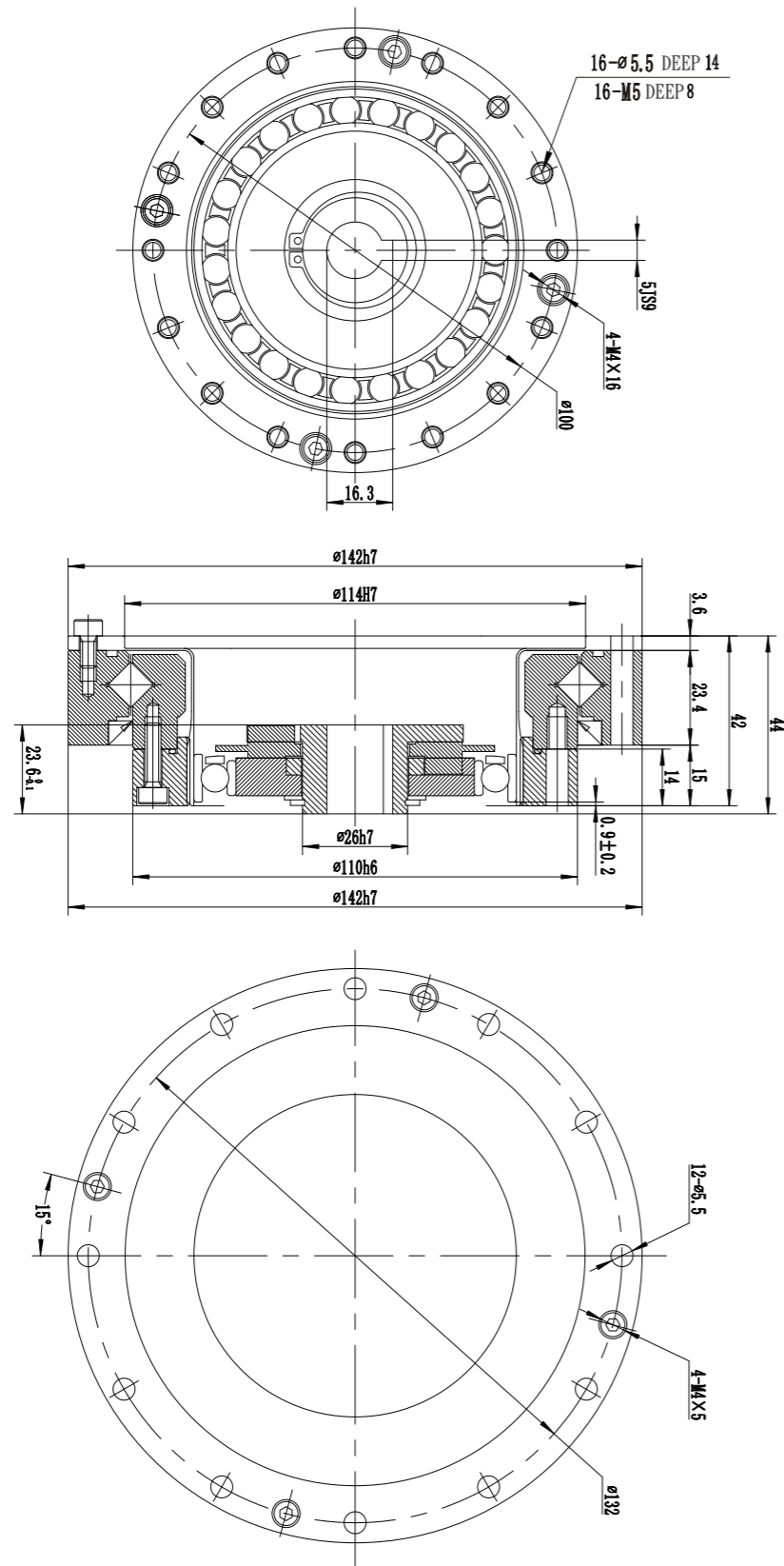

WSHG-III Series Reducer

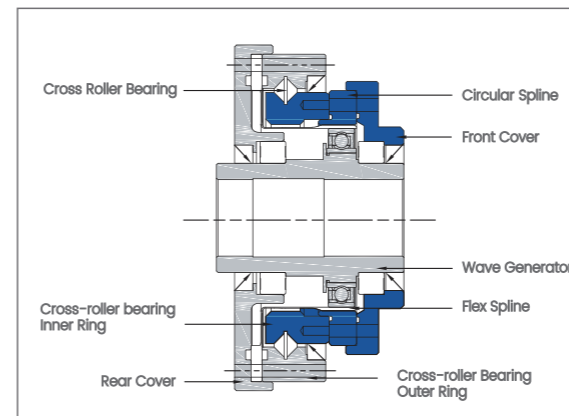

WSHG-III series reducer

WSHG -III Series flex spline is a hollow hat-shaped standard structure. The wave generator is a hollow elliptical shaft with a large diameter. The reducer is designed with a roller cross bearing inside, fully sealed, easy to install, and suitable for applications of threading through the reducer center.

WSHG-III Series Features

1. Large diameter, hollow hole
2. Compact, simple design
3. No backlash
4. Input-output coaxial
5. Excellent positioning and rotation accuracy

WSHG-III Series Performance Parameter

Model	Ratio	Rated torque at input speed 2000r/min N*m	Allowable maximum torque at start and stop N*m	Maximum allowable load torque N*m	Instantaneous Maximum torque N*m	Maximum allowable input speed r/min	Allowable average input speed r/min	Backlash arc sec	Life Span hrs
14	50	6.3	21	8	42	8000	3500	20	10000
	80	9	27	13	55			20	15000
	100	9	33	13	63			15	15000
17	50	19	40	31	82	7000	3500	20	10000
	80	26	50	32	102			20	15000
	100	28	63	46	129			15	15000
20	50	30	66	40	115	6000	3500	20	10000
	80	40	87	55	149			20	15000
	100	47	97	58	172			15	15000
	120	47	102	58	172			15	15000
25	50	46	114	65	218	5500	3500	20	10000
	80	74	160	102	299			20	15000
	100	78	184	126	332			15	15000
	120	78	196	126	356			15	15000
32	50	89	253	126	448	4500	3500	20	10000
	80	138	356	196	665			15	15000
	100	160	370	253	757			15	15000
	120	160	413	253	803			15	15000

WSHG-III Series Dimensional Drawing

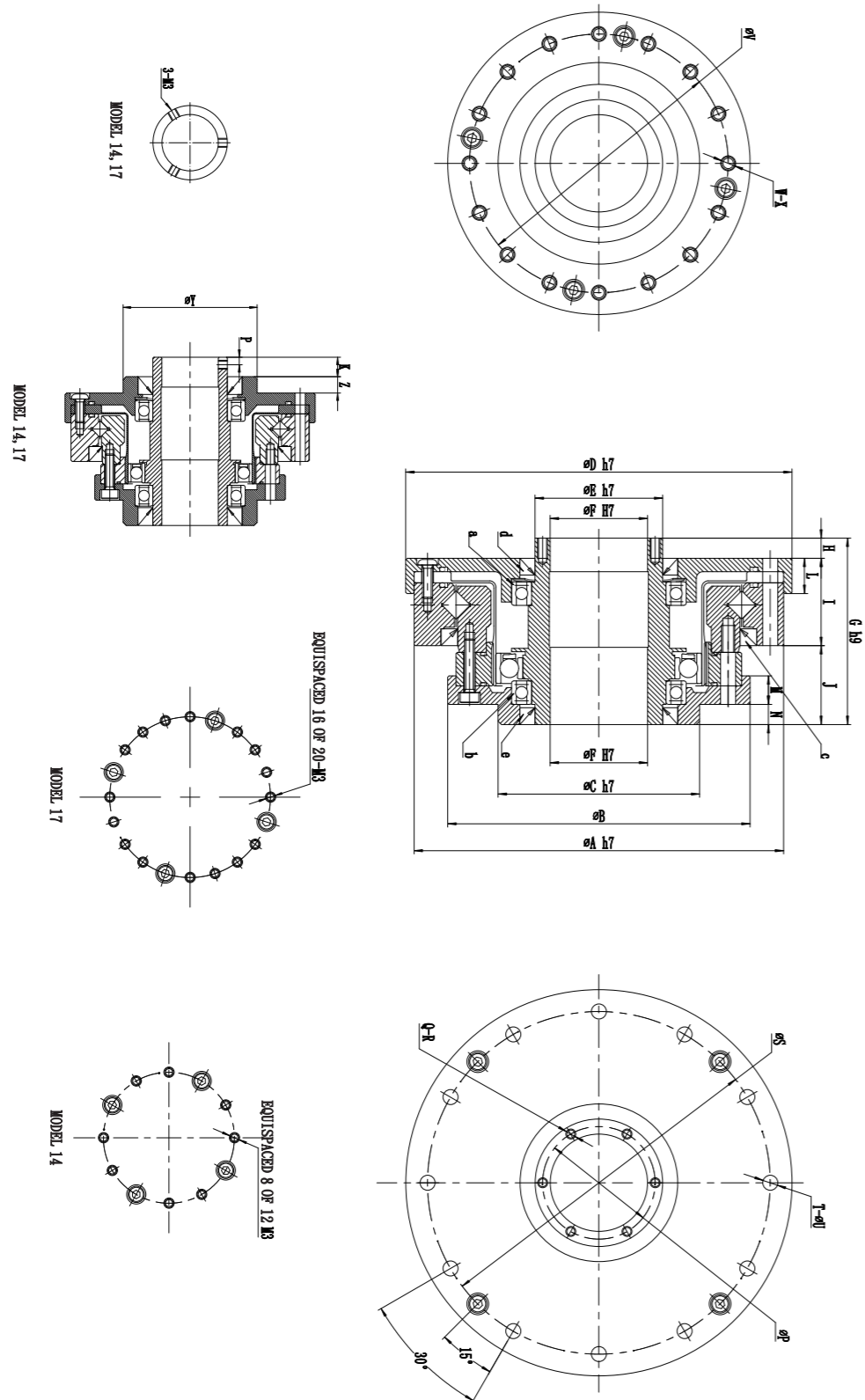

WSHG-III Series Dimension

Symbol	Model	14	17	20	25	32
$\phi A h7$		70	80	90	110	142
ϕB		54	64	75	90	115
$\phi C h7$		36	45	50	60	85
$\phi D h7$		74	84	95	115	147
$\phi E h7$		20	25	30	38	45
$\phi F H7$		14	19	21	29	36
G		52.5	56.5	51.5	55.5	65.5
H		12	12	5	6	7
I		20.5	23	25	26	32
J		20	21.5	21.5	23.5	26.5
K		6.5	6.5	-	-	-
L		9	10	10.5	10.5	12
M		8	8.5	9	8.5	9.5
N		7.5	8.5	7	6	5
O		21.7	23.9	25.5	29.6	36.4
$\phi P (P)$		(2.50)	(2.50)	25.5	33.5	40.5
Q		3	3	6	6	6
R		M3	M3	M3×6	M4×7	M5×8
ϕS		64	74	84	102	132
T		8	12	12	12	12
ϕU		3.5	3.5	3.5	4.5	5.5
ϕV		44	54	62	77	100
W		Equispaced 8 of 12	Equispaced 16 of 20	16	16	16
X		M3×5 $\phi 3.5 \times 11.5$	M3×6 $\phi 3.5 \times 12$	M3×6 $\phi 3.5 \times 13.5$	M4×7 $\phi 4.5 \times 15.5$	M5×8 $\phi 5.5 \times 20.5$
ϕY		36	45	-	-	-
Z		5.5	5.5	-	-	-
a		6804ZZ	6805ZZ	6806ZZ	6808ZZ	6909ZZ
b		6804ZZ	6805ZZ	6806ZZ	6808ZZ	6809ZZ
c		D49585	D59685	D69785	D84945	D1101226
d		S20304.5	S25356	S30405	S38475	S45607
e		S20304.5	S25356	S30405	S38475	S45555
Weight(Kg)		0.71	1	1.38	2.1	4.5

WSHG-14-XXX-III

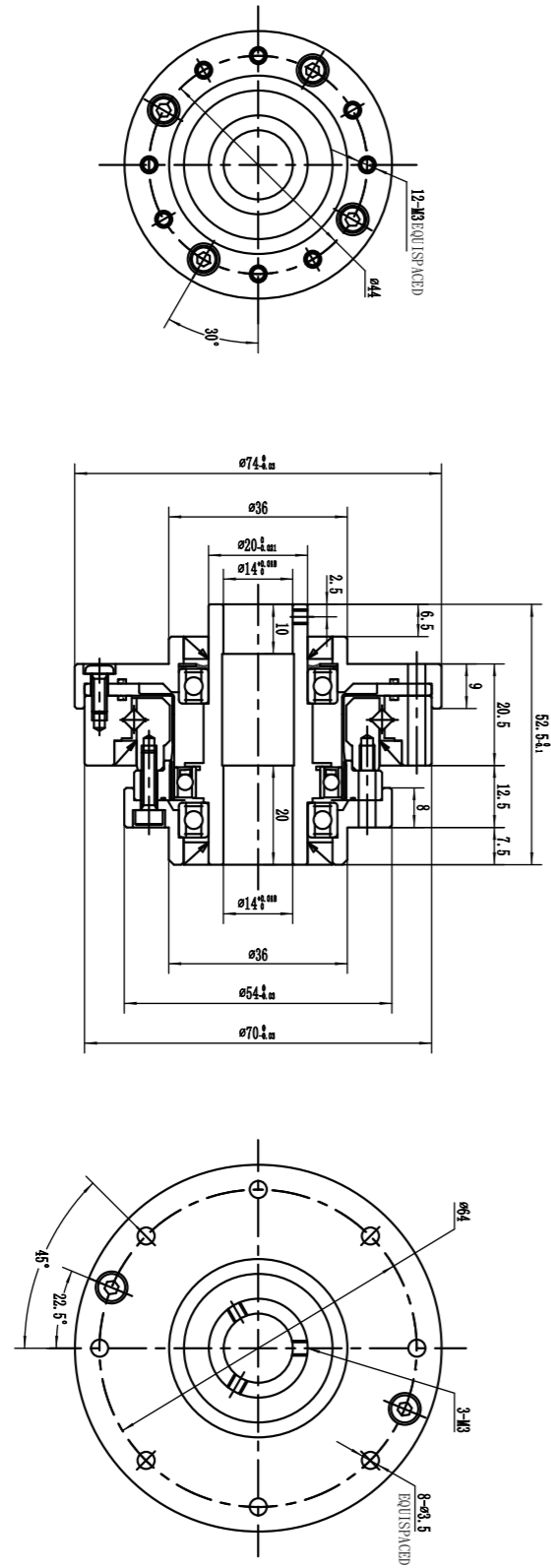

WSHG-17-XXX-III

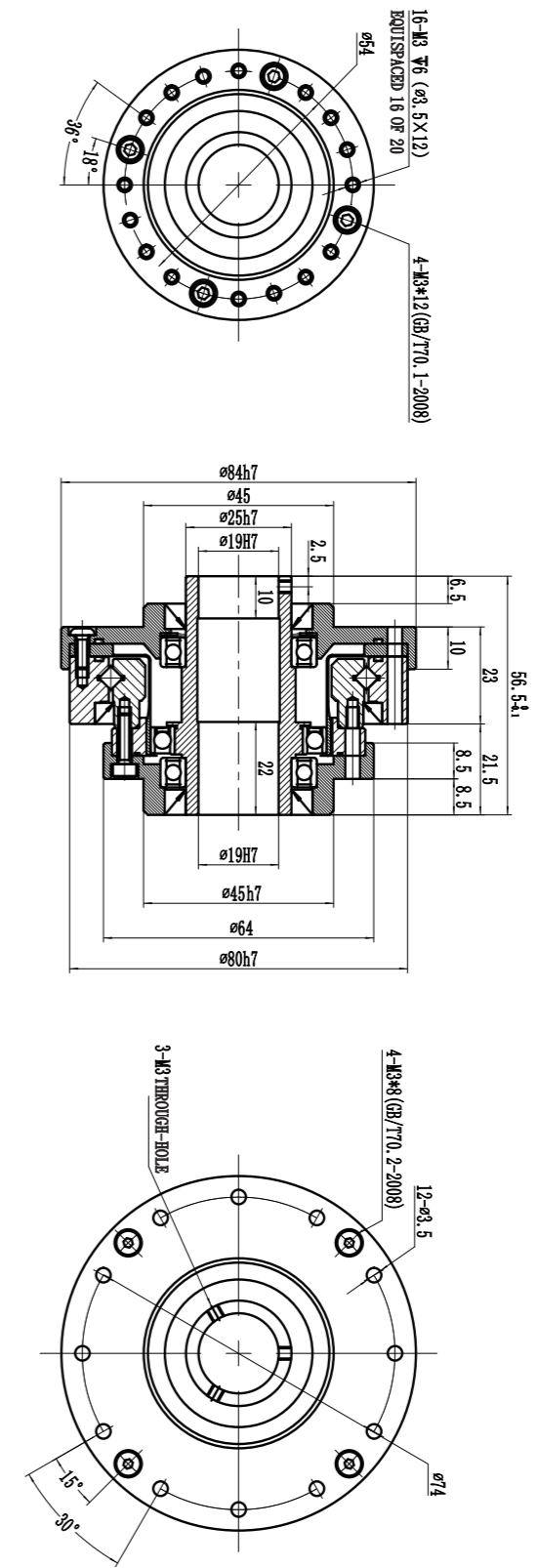

WSHG-20-XXX-III

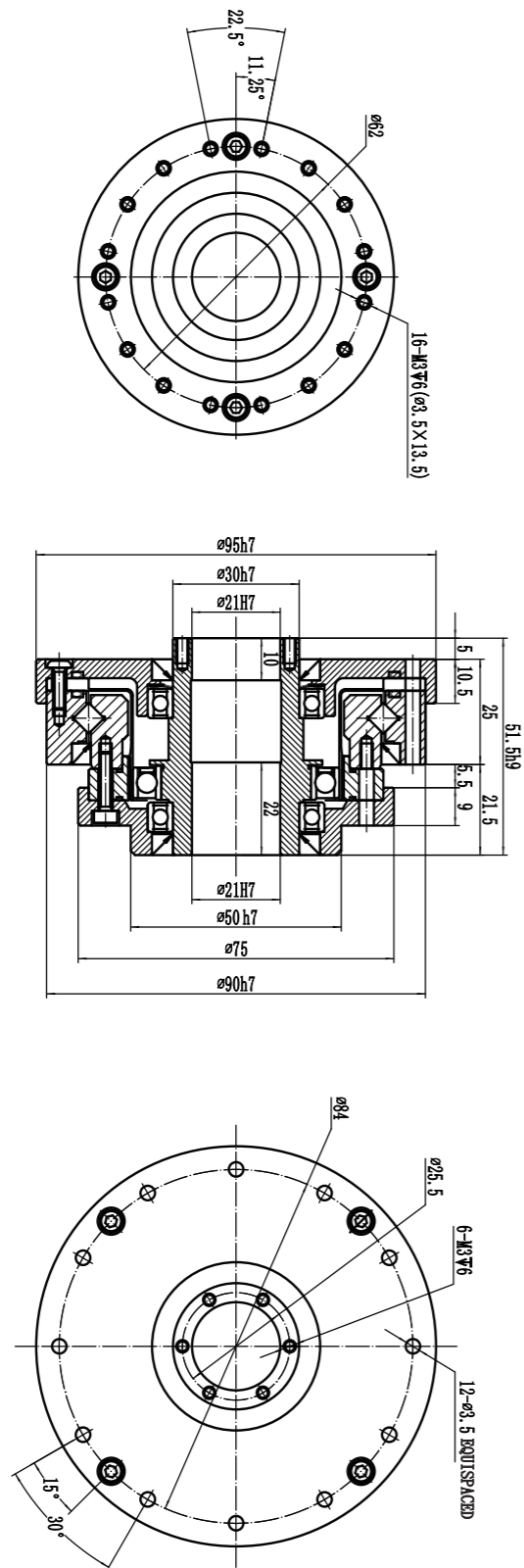

WSHG-25-XXX-III

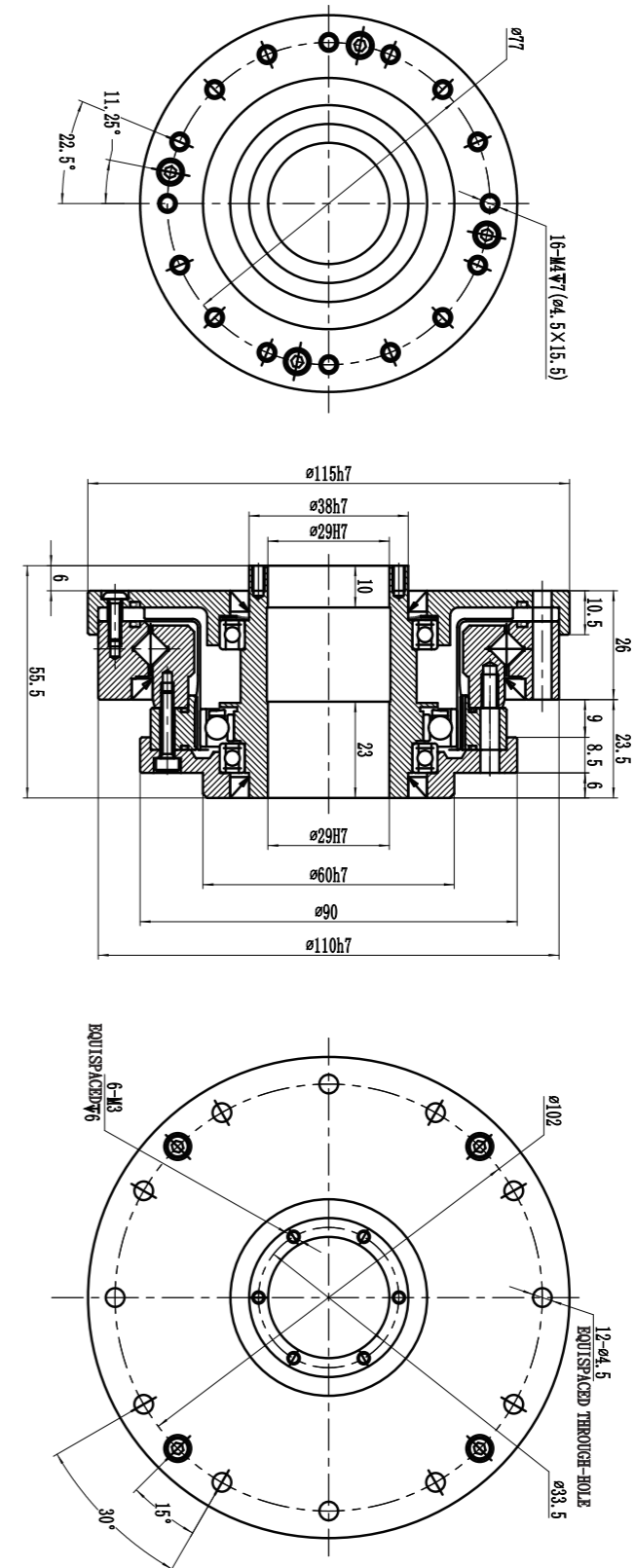

WSHG-32-XXX-III

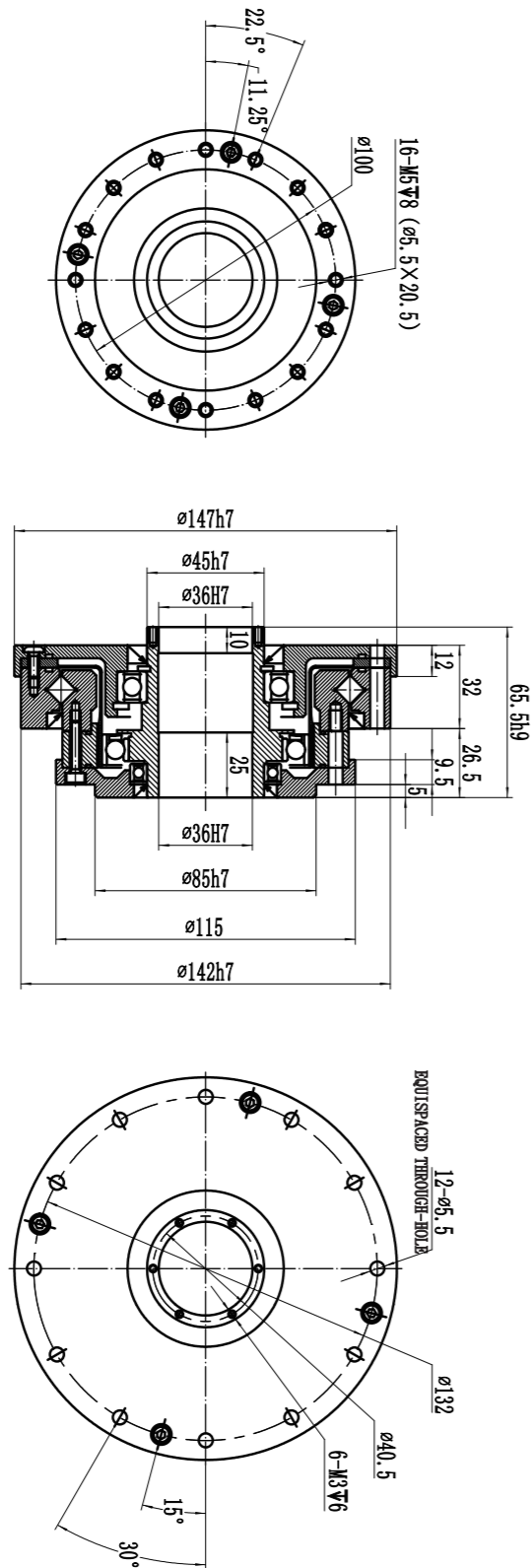

WSHG-IV Series Reducer

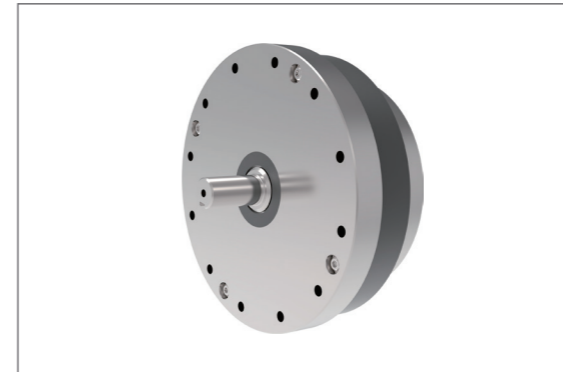

WSHG-IV series reducer

WSHG-IV Series flex spline is a hollow top hat-shaped standard structure. The wave generator comes with an input shaft. And the roller cross bearing is inside the reducer. All is in a fully enclosed structure, simple to install, suitable for occasions where bevel gear or synchronous belt drive is required at the input end.

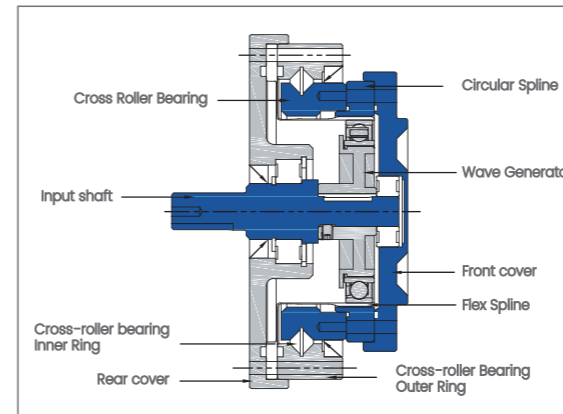

WSHG-IV Series Features

1. Applicable for multiple input
2. Compact, simple design
3. No backlash
4. Input-output coaxial
5. Excellent positioning and rotation accuracy

WSHG-IV Series Performance Parameter

Model	Ratio	Rated torque at input speed 2000r/min N*m	Allowable maximum torque at start and stop N*m	Maximum allowable load torque N*m	Instantaneous Maximum torque N*m	Maximum allowable input speed r/min	Allowable average input speed r/min	Backlash arc sec	Life Span hrs
14	50	6.3	21	8	42	8000	3500	20	10000
	80	9	27	13	55			20	15000
	100	9	33	13	63			15	15000
17	50	19	40	31	82	7000	3500	20	10000
	80	26	50	32	102			20	15000
	100	28	63	46	129			15	15000
20	50	30	66	40	115	6000	3500	20	10000
	80	40	87	55	149			20	15000
	100	47	97	58	172			15	15000
	120	47	102	58	172			15	15000
25	50	46	114	65	218	5500	3500	20	10000
	80	74	160	102	299			20	15000
	100	78	184	126	332			15	15000
	120	78	196	126	356			15	15000
32	50	89	253	126	448	4500	3500	20	10000
	80	138	356	196	665			15	15000
	100	160	370	253	757			15	15000
	120	160	413	253	803			15	15000

WSHG-IV Series Dimensional Drawing

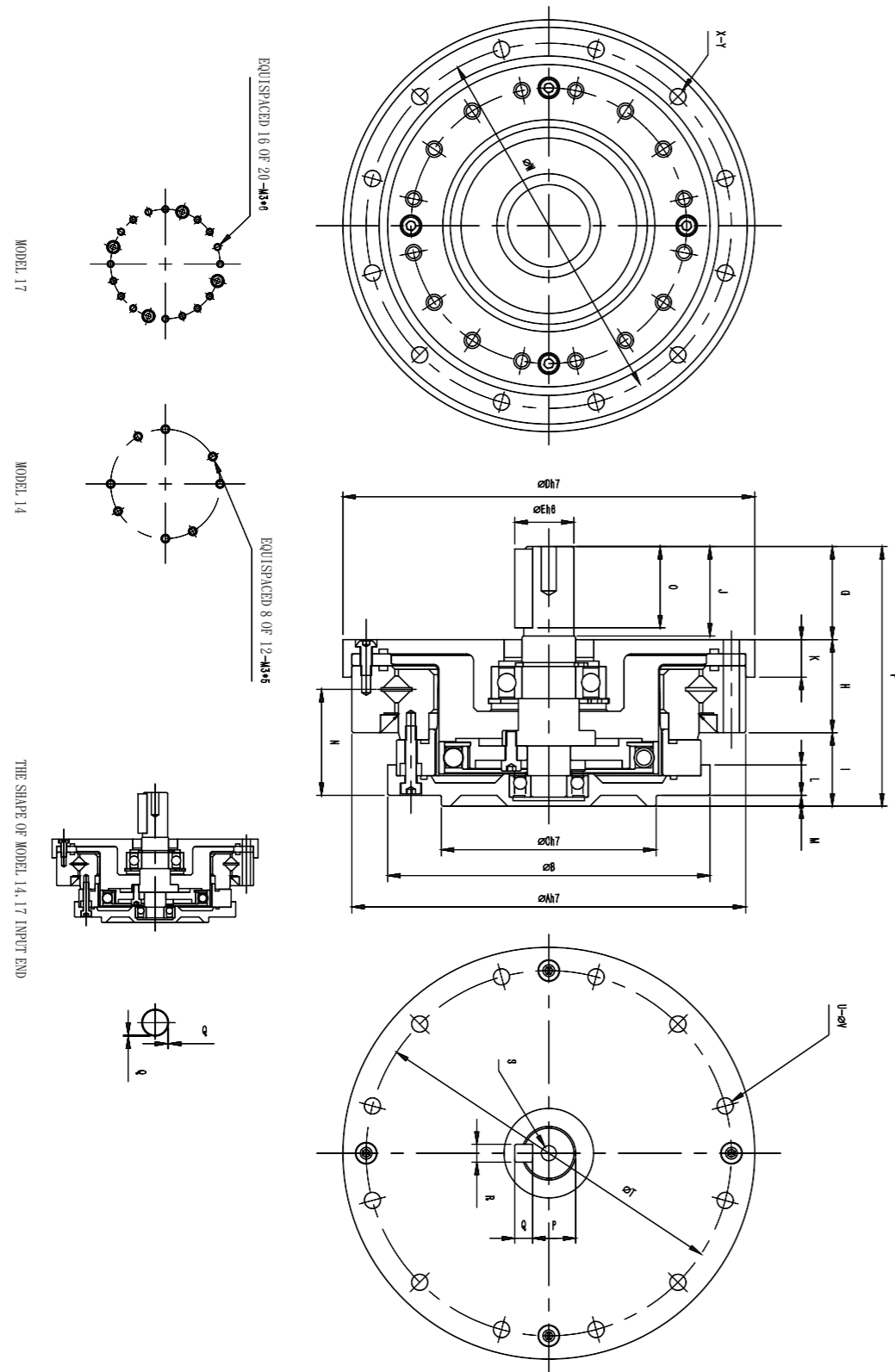

WSHG-IV Series Dimension

Model Symbol	14	17	20	25	32
ΦA h7	70	80	90	110	142
ΦB	54	64	75	90	115
ΦC h7	36	45	50	60	85
ΦD h7	74	84	95	115	147
ΦE h6	6	8	10	14	14
F	50.5	56	63.5	72.5	84.5
G	15	17	21	26	26
H	20.5	23	25	26	32
I	15	16	17.5	20.5	26.5
J	14	16	20	25	25
K	9	10	10.5	10.5	12
L	8	8.5	9	8.5	9.5
M	2.5	3	3	3	5
N	21.7	23.9	25.5	29.6	36.4
O	11	12	16.5	22.5	22.5
P	-	-	8.2	11	11
Q	0.5	0.5	3 ^{-0.025}	5 ^{-0.030}	5 ^{-0.030}
R	-	-	3 ^{-0.025}	5 ^{-0.030}	5 ^{-0.030}
S	-	-	M3×6	M5×10	M5×10
φT	64	74	84	102	132
U	8	12	12	12	12
ΦV	3.5	3.5	3.5	4.5	5.5
ΦW	44	54	62	77	100
X	EQUISPACED 8 OF 12	EQUISPACED 16 OF 20	16	16	16
Y	M3×5 Φ3.5×11.5	M3×6 Φ3.5×12	M3×6 Φ3.5×13.5	M4×7 Φ4.5×15.5	M5×8 Φ5.5×20.5
a	698ZZ	6900ZZ	6902ZZ	6002ZZ	6004ZZ
b	695ZZ	697ZZ	698ZZ	6900ZZ	6902ZZ
c	D49585	D59685	D69785	D84945	D1101226
d	G8184	D10205	D15255	D15255	D20355
Weight(Kg)	0.66	0.94	1.38	2.1	4.4

WSHG-14-XXX-IV

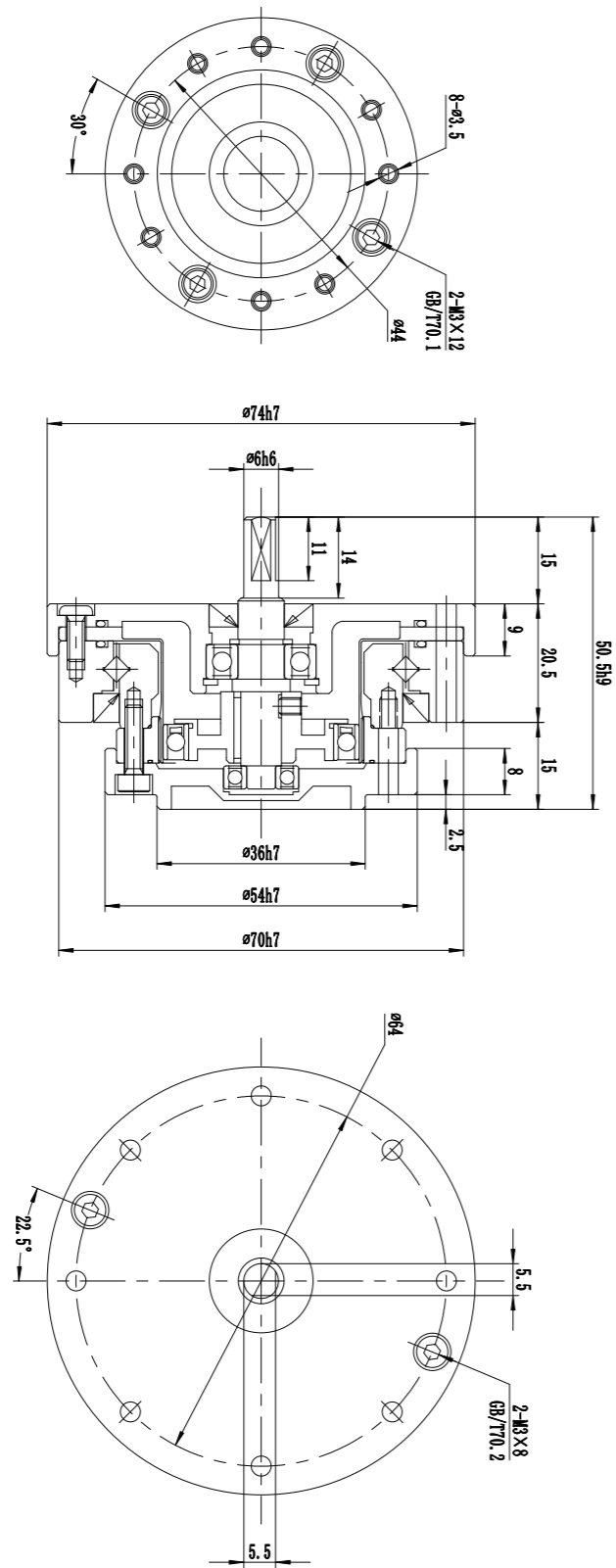

WSHG-17-XXX-IV

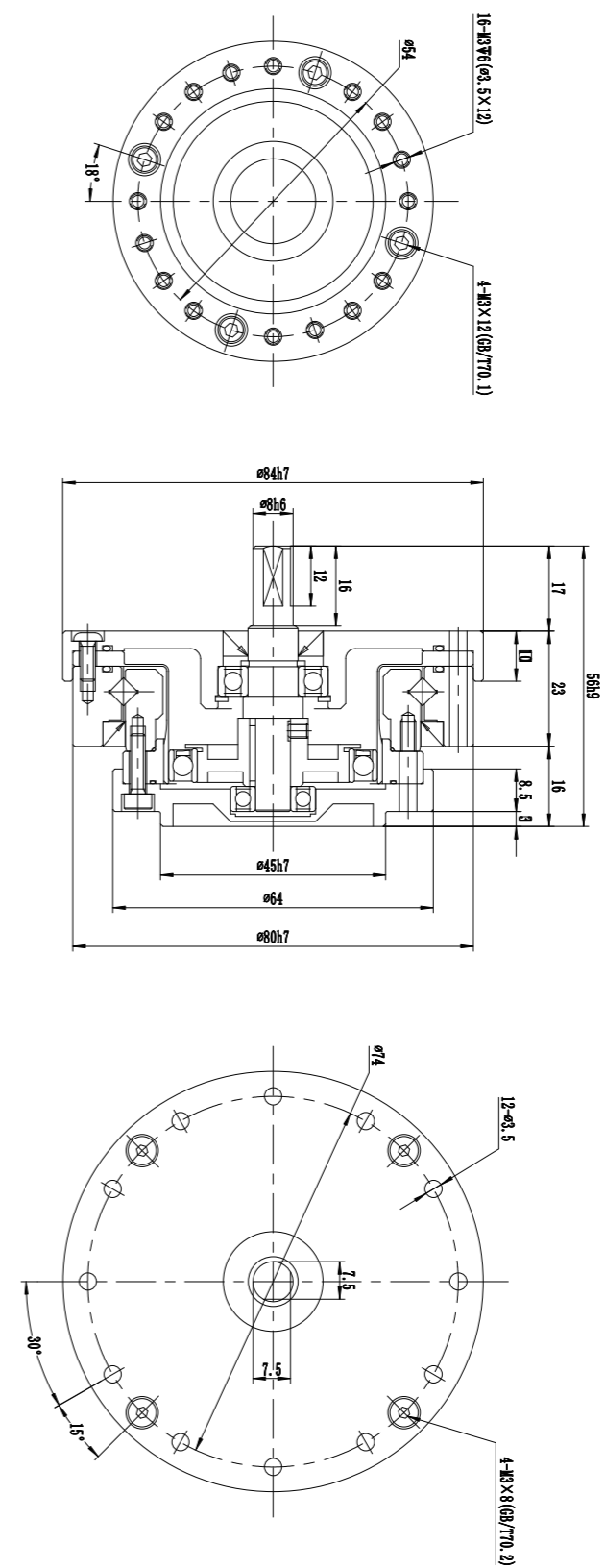

WSHG-20-XXX-IV

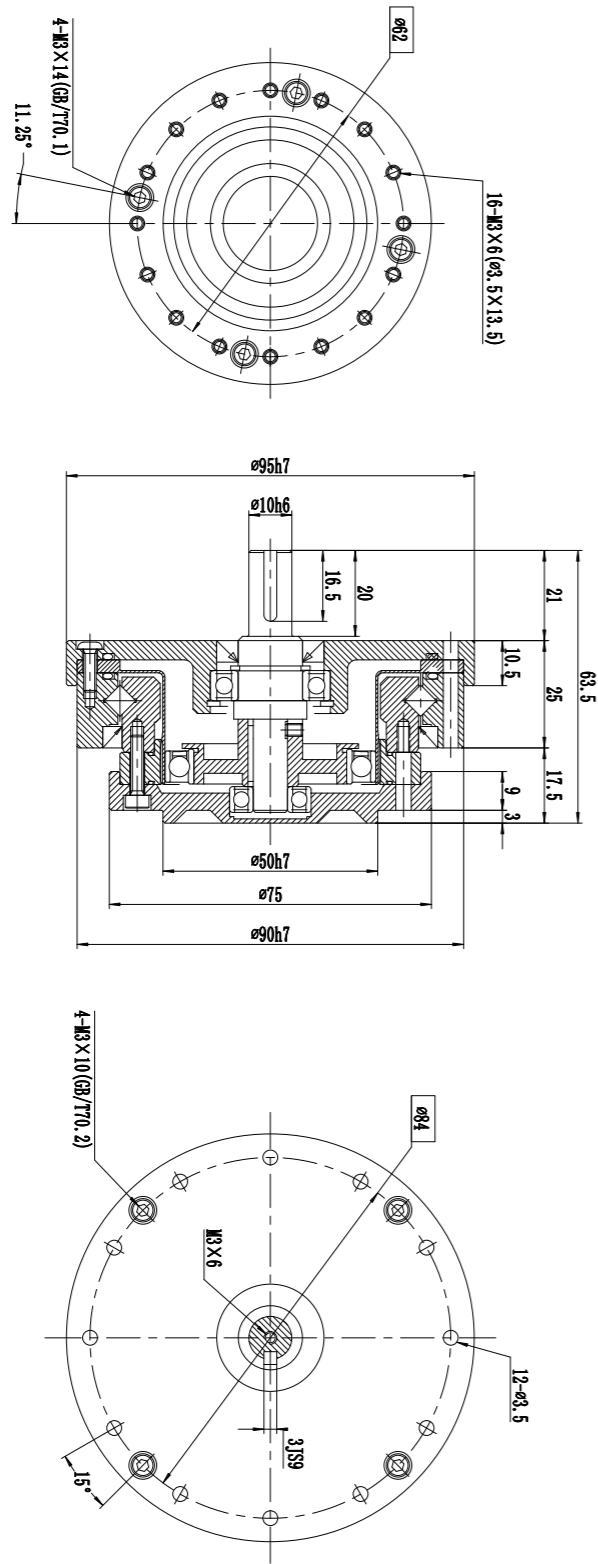

WSHG-25-XXX-IV

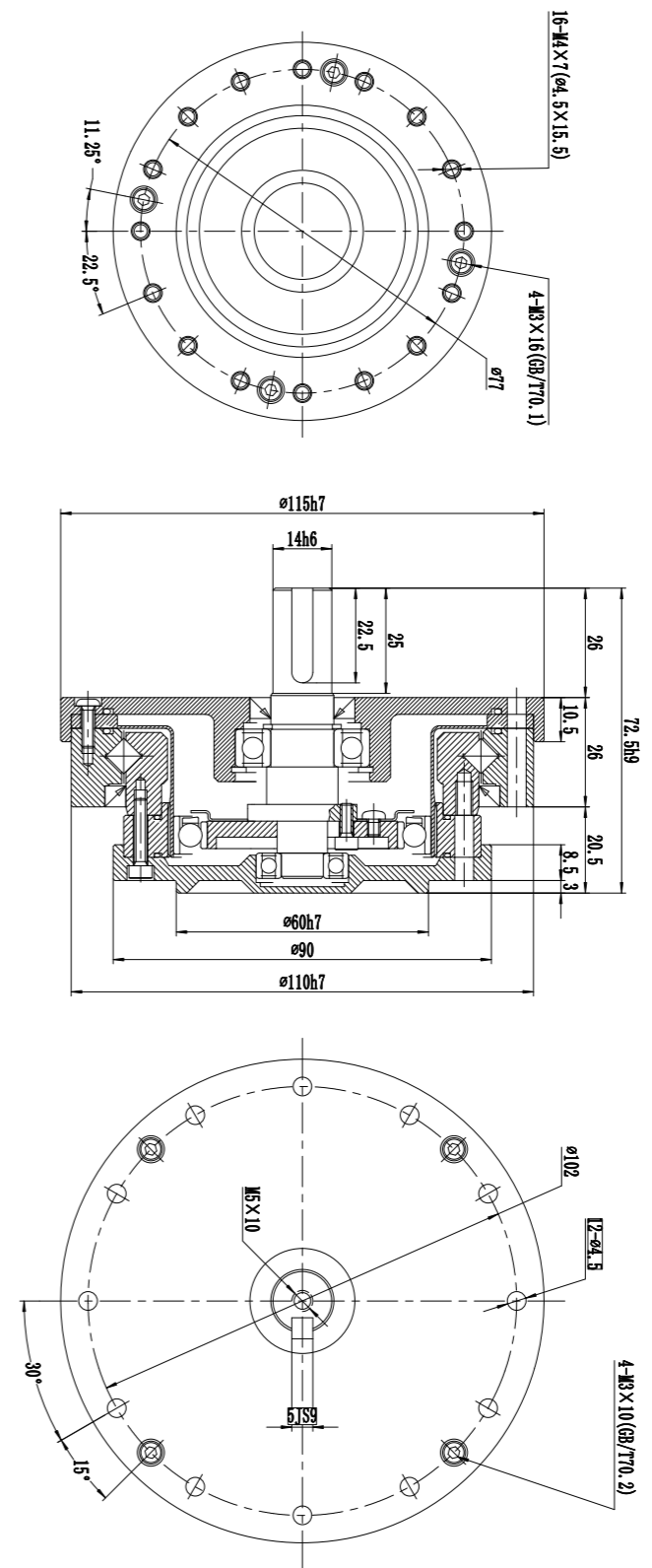

WSHG-32-XXX-IV

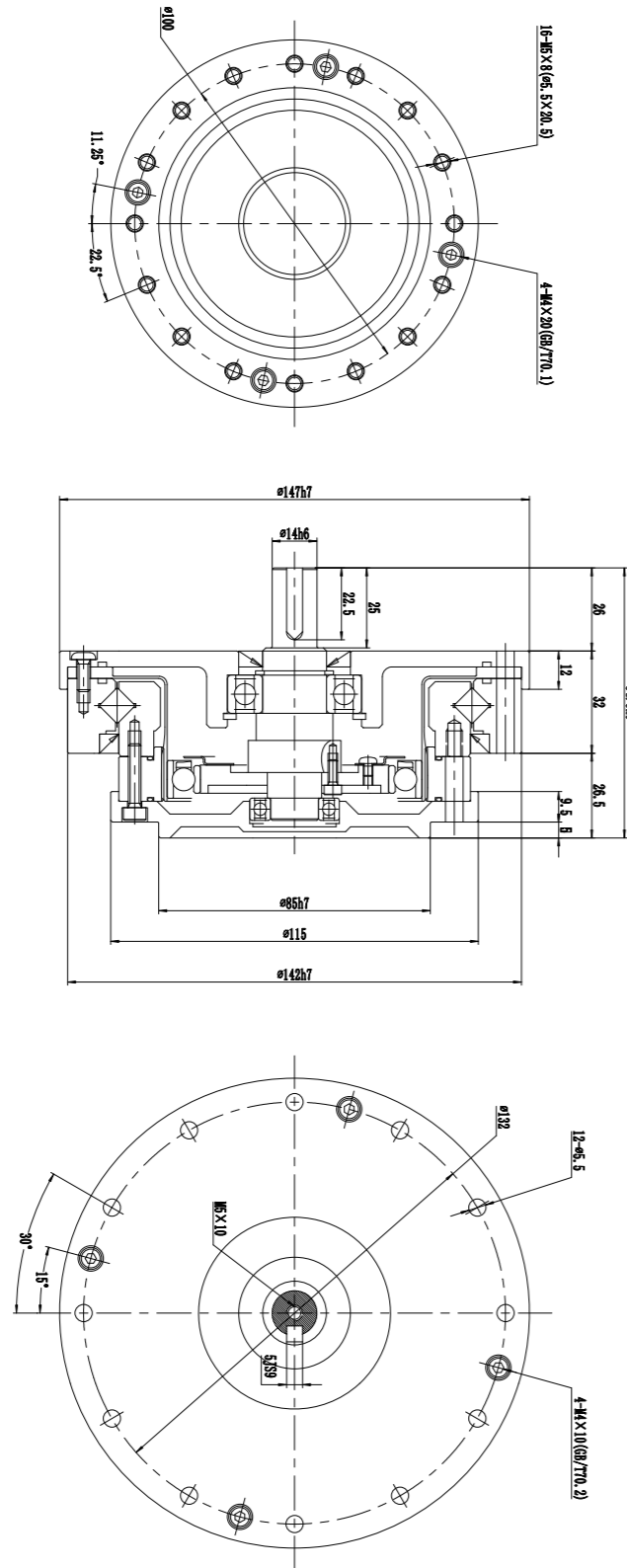

WSHD-I Series Reducer

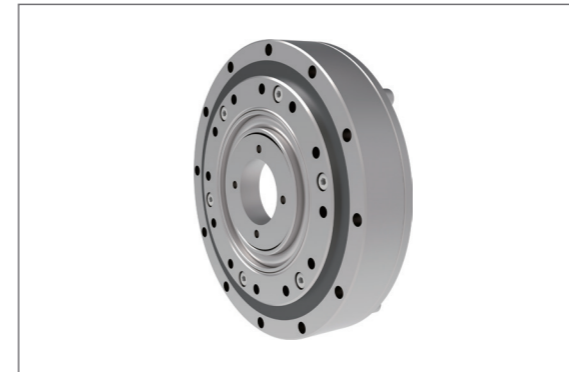

WSHD-I series reducer

Hollow top hat-shaped type, simple combination (super flat hollow shaft) The WSHD- I Series is a type that pursues the flatness limit. Comparing with the WSHG series, the axial length is shortened by 50%. The flex spline has an ultra-thin hollow structure. The output end is equipped with high-rigidity roller cross bearings, which is very suitable for flat design applications.

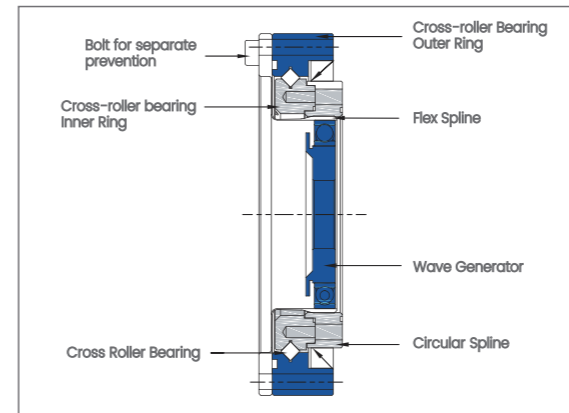

WSHD-I Series Features

1. Applicable for multiple input
2. Compact, simple design
3. No backlash
4. Input-output coaxial
5. Excellent positioning and rotation accuracy

WSHD-I Series Performance Parameter

Model	Ratio	Rated torque at input speed 2000r/min N*m	Allowable maximum torque at start and stop N*m	Maximum allowable load torque N*m	Instantaneous Maximum torque N*m	Maximum allowable input speed r/min	Allowable average input speed r/min	Backlash arc sec	Life Span hrs
14	50	3.5	11.4	4.6	23	8000	3500	20	10000
	100	5.1	18	7	33			10	15000
17	50	10.5	22	17	46	7000	3500	20	10000
	100	15	35	26	67			10	15000
20	50	16	37	23	66	6000	3500	20	10000
	100	27	54	32	90			10	15000

WSHD-I Series Dimensional Drawing

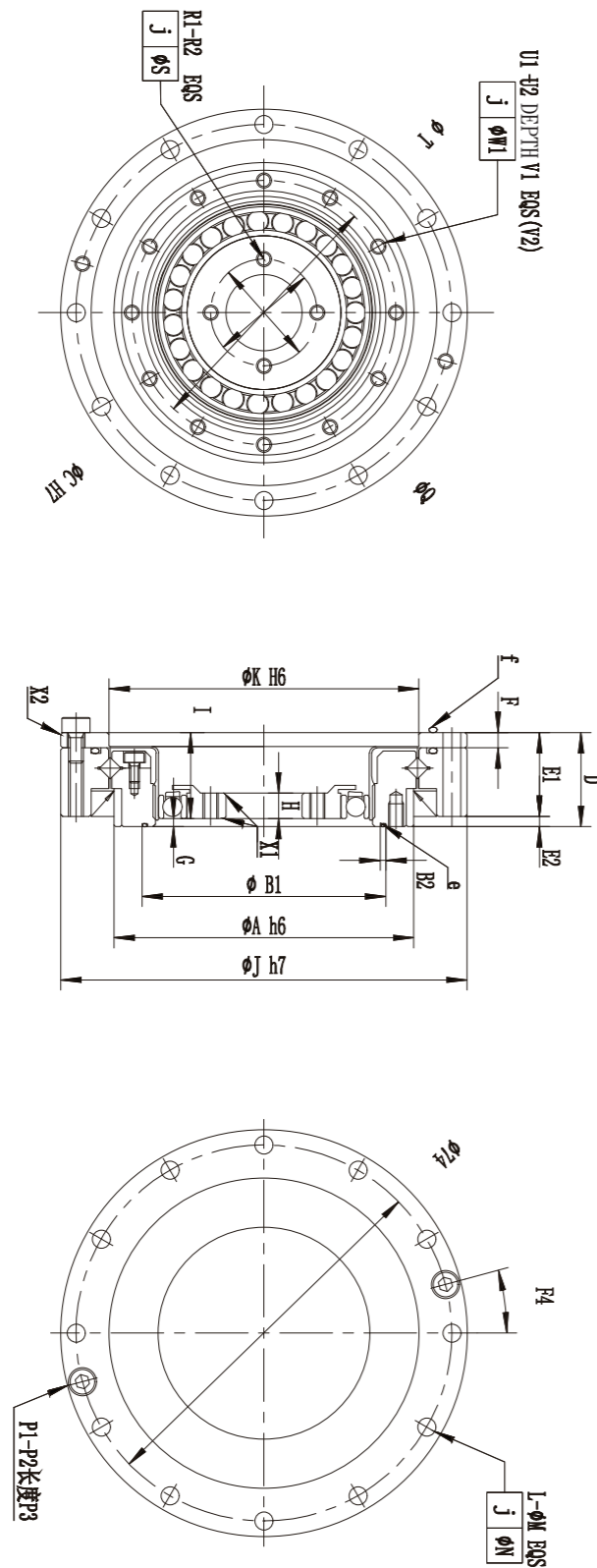

WSHD-I Series Dimension

Model Symbol	14	17	20
ϕA h6	49	59	69
ϕC H7	11	15	20
D	17.5	18.5	19
E1	15.5	16.5	17
E2	2	2	2
F	2.4	3	3
G	1.8±0.1	1.6±0.1	1.2±0.1
H	4	5	5.2
I	15.7	16.9	17.8
ϕJ h7	70	80	90
ϕK H6	50	61	71
L	8	12	12
ϕM	3.5	3.5	3.5
ϕN	0.25	0.25	0.25
ϕO	64	74	84
P1	2	2	2
P2	M3	M3	M3
P3	6	6	6
P4	22.5°	15°	15°
ϕQ	17	21	26
R1	4	4	4
R2	M3	M3	M3
ϕS	0.25	0.25	0.25
ϕT	43	52	61.4
U1	8	12	12
U2	M3	M3	M3
V1	5	5	5
V2	-	$\phi 3.5 \times 6$	$\phi 3.5 \times 5.3$
$\phi W1$	0.25	0.25	0.25
X1	C0.4	C0.4	C0.5
X2	C0.4	C0.4	C0.5
e	37.5X0.6	16.5X0.65	53.5X0.6
f	55X1.2	65.5X1.5	74.5X2
Weight(Kg)	0.33	0.42	0.52

WSHD-14-XXX-I

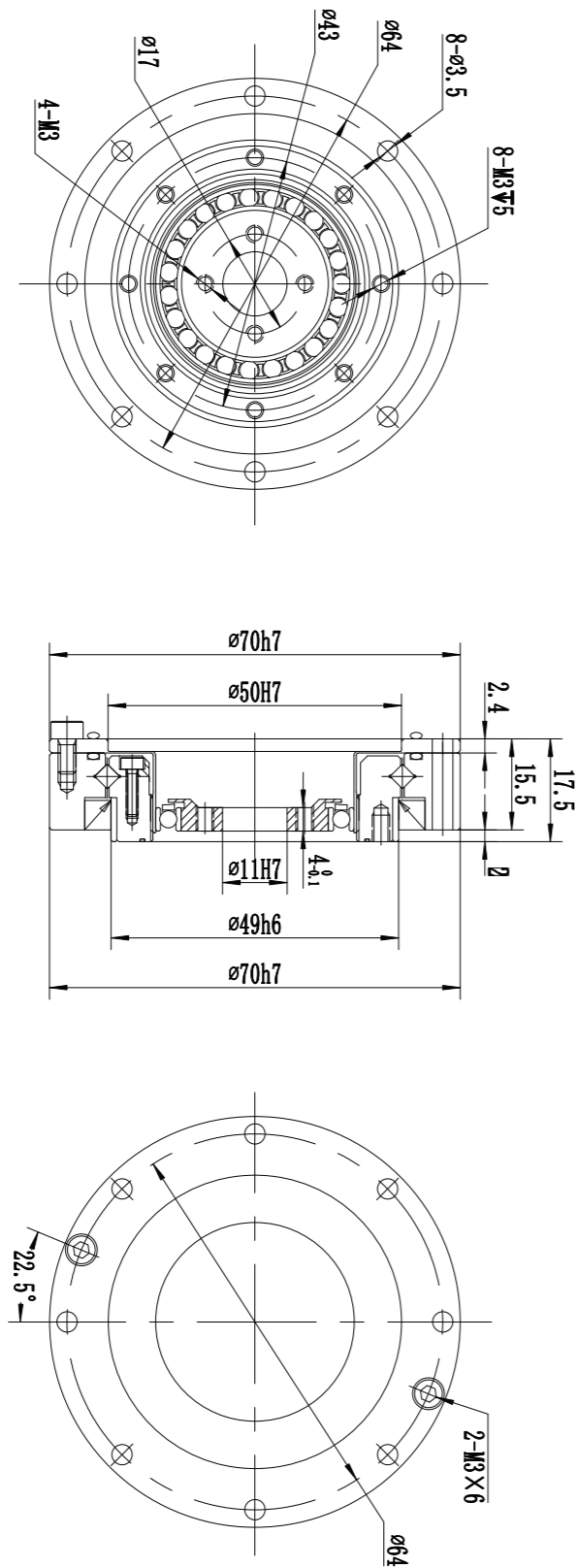

WSHD-17-XXX-I

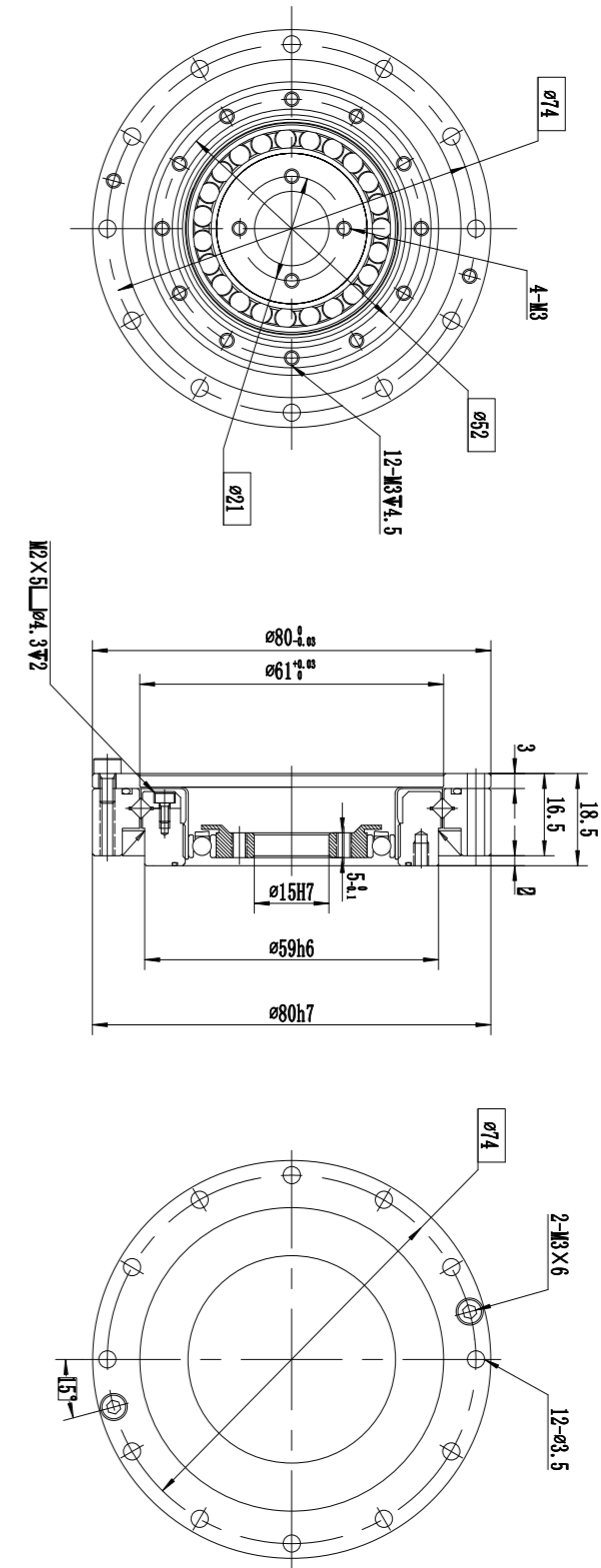

WSHD-20-XXX-I

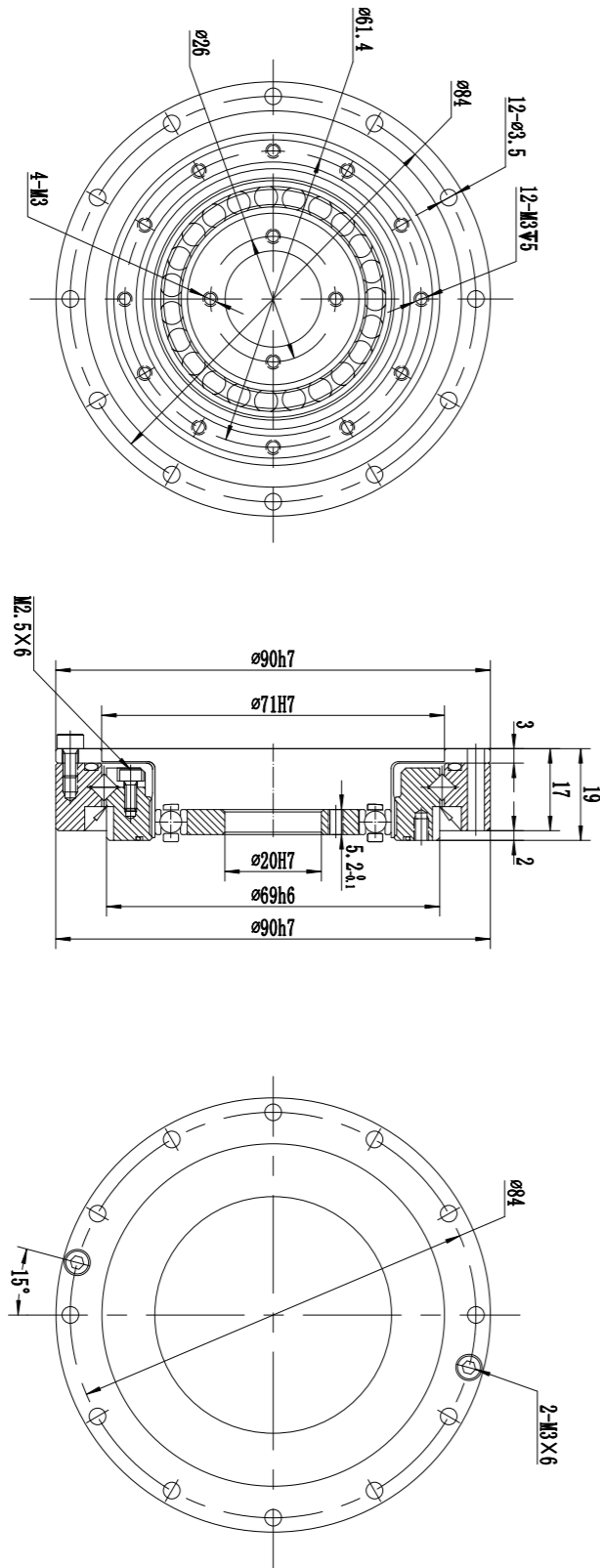

WCSD-I Series Reducer



WCSD-I series reducer

Cup type (super flat)

The WCSD-I Series is for committed to the light-weight and compact features of gear transmission, while inheriting the excellent performance of traditional products, its bold shape design of an super-flat structure makes it lightweight and compact, very suitable for use as a robot end joint and others.

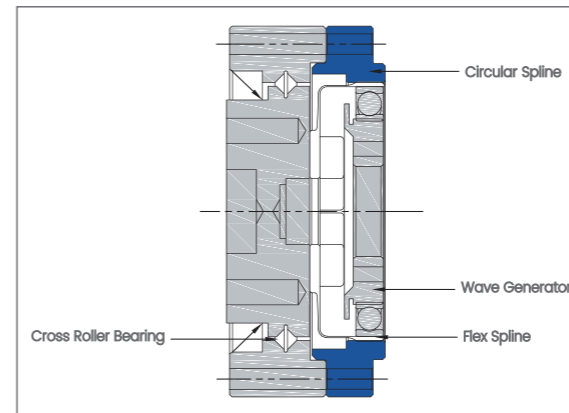

WCSD-I Series Features

1. Super flat structure
2. Lightweight & compact
3. Static torque capacity
4. Input-output coaxial
5. Excellent positioning and rotation accuracy

WCSD-I Series Performance Parameter

Model	Ratio	Rated torque at input speed 2000r/min N*m	Allowable maximum torque at start and stop N*m	Maximum allowable load torque N*m	Instantaneous Maximum torque N*m	Maximum allowable input speed r/min	Allowable average input speed r/min	Backlash arc sec	Life Span hrs
14	50	3.5	11.4	4.6	23	8000	3500	20	10000
	100	5.1	18	7	33			10	15000
17	50	10.5	22	17	46	7000	3500	20	10000
	100	15	35	26	67			10	15000
20	50	16	37	23	66	6000	3500	20	10000
	100	27	54	32	90			10	15000

WCSD-I Series Dimensional Drawing

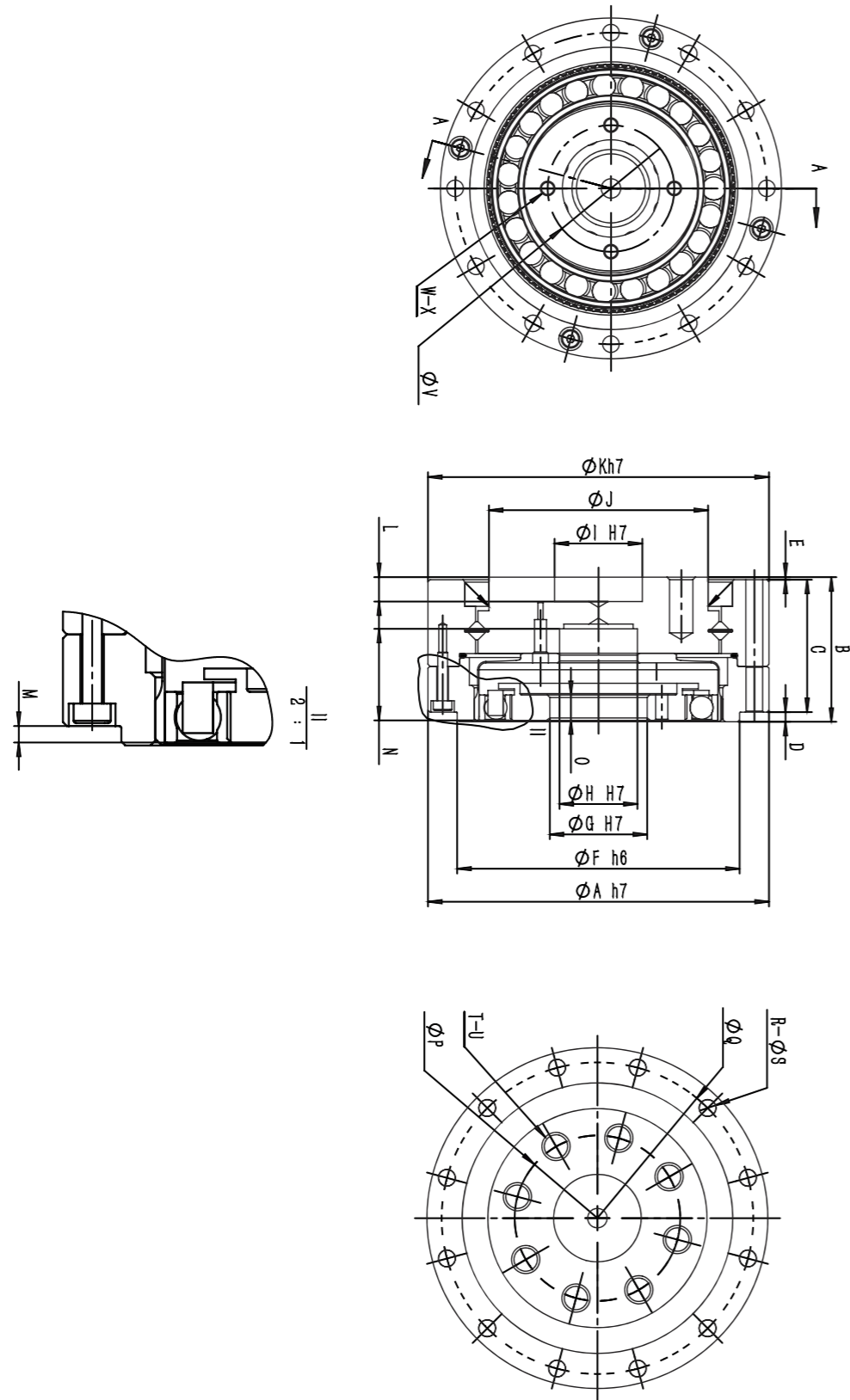

WCSD-I Series Dimension

Model Symbol	14	17	20
$\phi A h7$	70	80	90
B	22	22.7	26.8
C	21.5	22.2	24.5
$\phi D H7$	48	56	64
$\phi E H7$	11	15	20
ϕF	9	9	18
$\phi G H7$	30	34	40
ϕH	49	59	69
$\phi I h7$	70	80	90
J	4.9	5.4	4.8
K	2.5	2.5	2.5
L	12.9	13.4	16.8
M	2.8 ^{+0.2}	2.8 ^{+0.2}	2.8 ^{+0.2}
N	4 _{-0.1}	5 _{-0.1}	5.2 _{-0.1}
ϕO (PCD)	17	21	26
P	4	4	4
Q	M3	M3	M3
ϕR (PCD)	64	74	84
S	6	8	8
ϕT	3.4	3.4	3.4
ϕU (PCD)	42	50	60
V	8	10	8
W	M3*5	M3*6	M4*8
X	34.5*0.80	38*1.5	S48
Y	49*1.5	59.4*1.20	S70
Weight(Kg)	0.5	0.66	0.94

WCSD-14-XXX-I

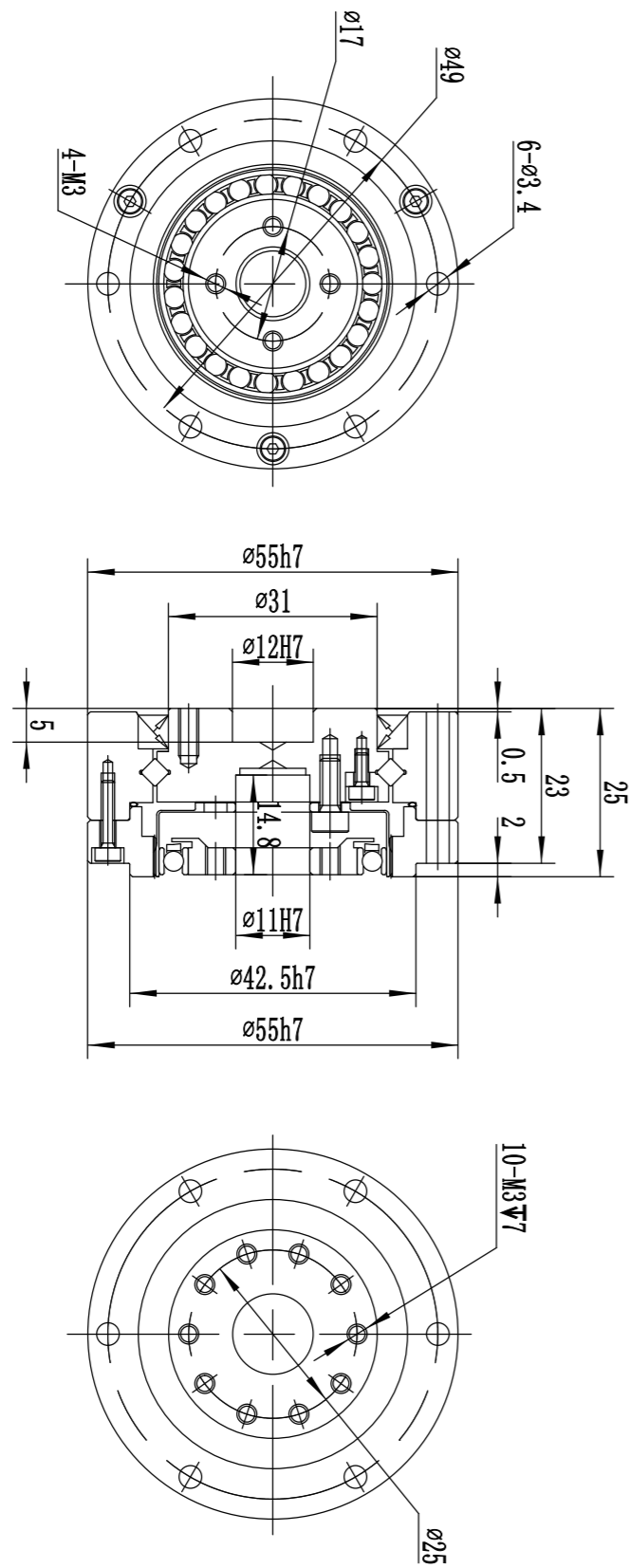

WCSD-17-XXX-I

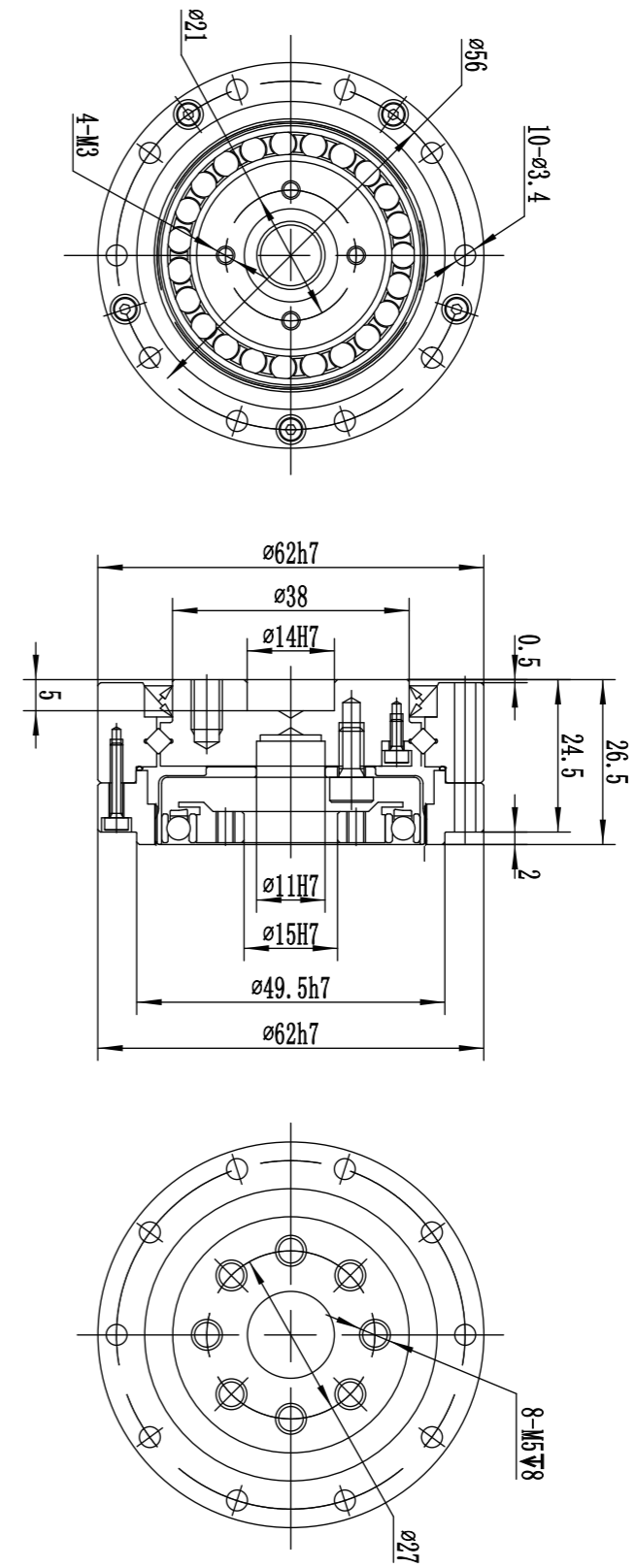

WCSD-20-XXX-I

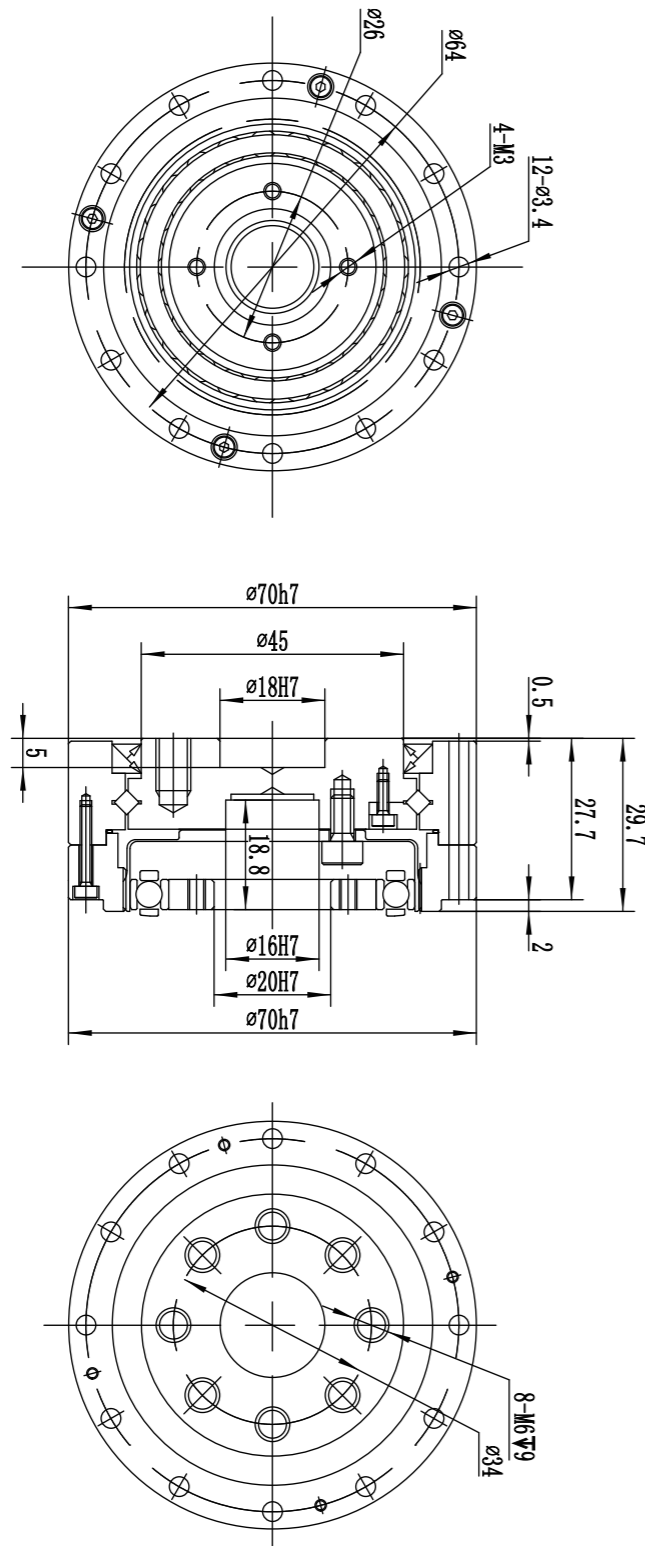

Installation

Design instruction

Please pay attention to the following points for better performance:

1. Please set the input shaft, circular spline, output shaft and housing as concentric.
 2. As wave generate can generate axial force, so the input shaft should be designed to the structure to bear the axial force.
 3. Make sure to fasten tightly for flex spline and output shaft screw as harmonic reducer is a compact unit and can generate big torque.
 4. Pls. design the housing inner size as per suggested, as flexible spline may generate elastic deformation.
 5. Must use the matching bearing for the input shaft and output shaft (leave space for 2 points support), a structure which can bear radial and axial load. Please do not apply excessive force to the wave generator and flexible wheel.
 6. Please ensure that the flange diameter for the installation of the flexible pulley does not exceed the diameter of the flex spline wheel hub, and make rounded corners on the flange connected with the diaphragm.
- Please design the size of each part according to the recommended size.
7. Fix the wheel hub of the wave generator with c-type clasp. Make sure that the hook part of the clasp does not contact the housing.

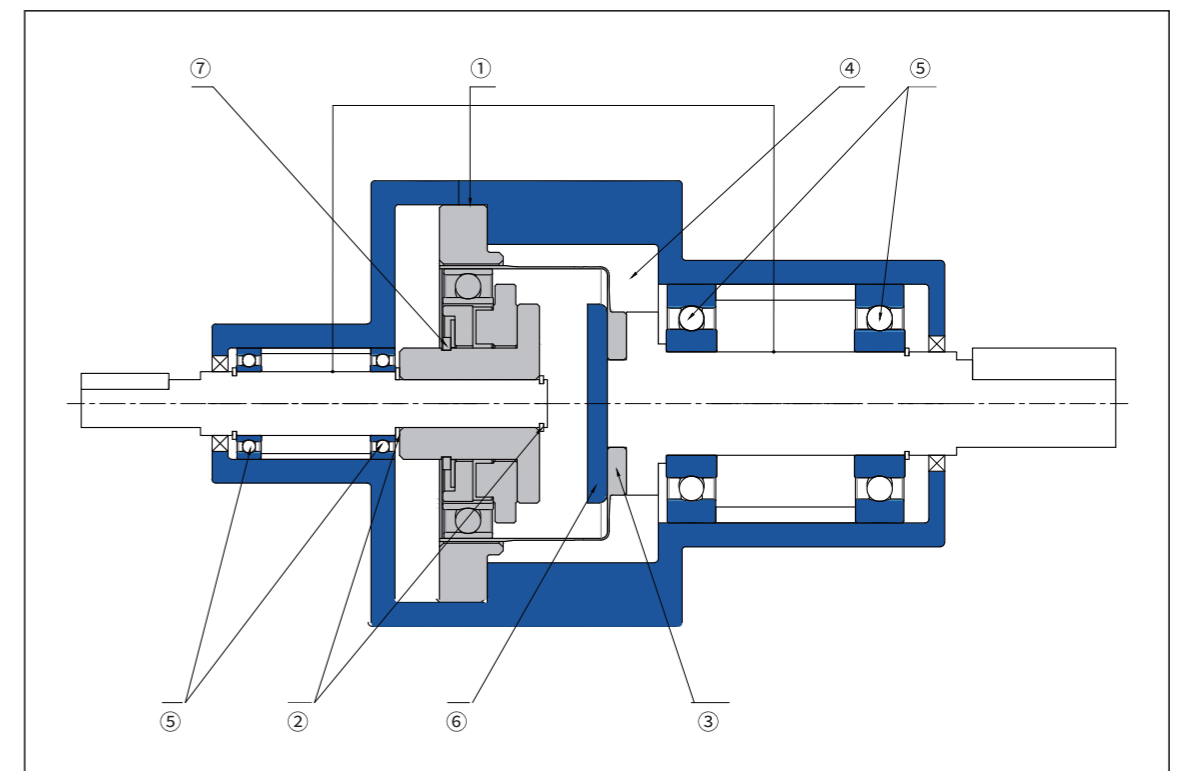

Sealing Structure

To prevent grease leakage and maintain high durability of reducer, the following sealing structure must be used.

1. Rotating motion: oil seal (spring embedded), please check if scratches on shaft side.
2. Flange mounting surface: O-ring, sealant. Please pay attention to whether any skewed or engagement of O-ring. (Below table for O-ring/slot size)
3. Screw hole: use screw with sealing or sealing tape.

Necessary seal locations		Recommend sealing method
The output side	The through-hole in the center of the output flange and the assembly surface of the output flange	Use O-ring (attached to our products)
	Mounting screw	Screw with sealing effect
The Input side	Flange mounting surface	Use O-ring (attached to our products)
	Motor output shaft	If there is no oil seal, install the oil seal on the installation flange of the motor

Reducer installation seal O-ring/groove size table

Product model	Flex Spline side				Circular Spline side			
	O-RING	O-GROOVE			O-RING	O-GROOVE		
		∅D1	∅D2	L1		∅D3	∅D4	L2
WHSG-14-II	55*1.2	53.3	56.5	0.89	37.5*0.6	36.5	38.1	0.45
WHSG-17-II	65.5*1.5	64.1	68.1	1.1	45.5*0.65	45	47	0.45
WHSG-20-II	74.5*2	72.6	78	1.5	52.2*0.8	52.6	54.6	0.6
WHSG-25-II	91.7*1.8	90	94.8	1.35	66*1.2	66	69	0.9
WHSG-32-II	119.5*2	117.6	123	1.5	86*1.5	86	90	1.1

Reducer installation seal O-ring/groove size table

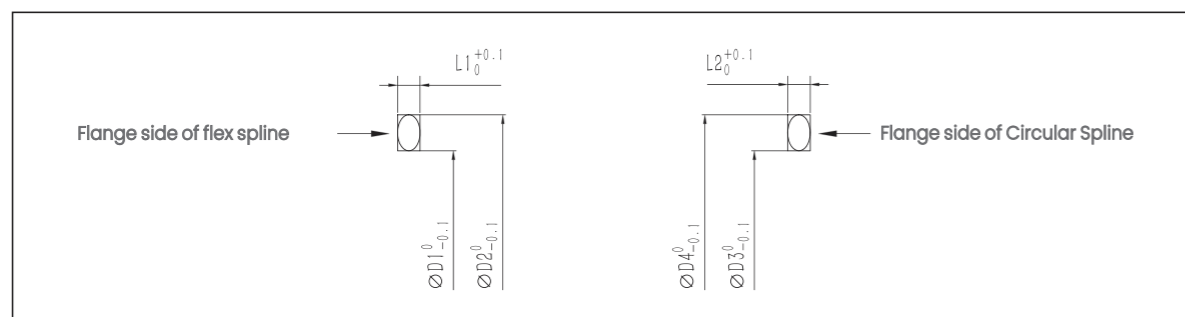

Assembly Precautions

Improper assembly may cause vibrate, abnormal sound, etc. problem, so please follow the following assembly precautions:

1. Attentions to wave generator

- (1) please avoid applying excessive force to the bearing part of the wave generator during assembly. The insertion can be carried out smoothly by rotating the wave generator.
- (2) when using a integrated wave generator, please pay special attention to control the center deviation and the influence of skew within the recommended value.

2. Attentions to circular spline

- (1) Check if the flatness of the installation surface is good and if there is any skew.
- (2) Check if the hole part of the screw is uplifted, with residual burr or foreign body.
- (3) Check if chamfering and avoidance processing have been carried out on the assembly part of the shell to avoid interference with the circular spline.
- (4) when the steel wheel is assembled to the shell, check if it can rotate and whether there is interference and clamping.
- (5) when inserting the bolt toward the bolt hole for installation, check if the bolt hole is in the correct position, whether the bolt is in contact with the circular spline due to the skew machining of the bolt hole and other reasons, so that the bolt rotation becomes heavy.
- (6) please do not tighten the bolts according to the specified torque at one time. Please tighten them temporarily with a force of about 1/2 of the specified torque before tightening them according to the specified torque.
- (7) Pin to the circular spline may cause low rotation accuracy, so please avoid it as much as possible.

3. Attention to flex spline

- (1) Check if the flatness of the installation surface is good and whether there is any skew.
- (2) Check if the hole part of the screw is uplifted, with residual burr or foreign body.
- (3) Check if chamfering and avoidance processing have been carried out on the assembly part of the shell to avoid interference with the flex spline.
- (4) when inserting the bolt toward the bolt hole for installation, confirm whether the bolt hole is in the correct position, whether the bolt is in contact with the flex spline due to the skew machining of the bolt hole and other reasons, so that the bolt rotation becomes heavy.
- (5) please do not tighten the bolts according to the specified torque at one time. Please tighten them temporarily with a force of about 1/2 of the specified torque before tightening them according to the specified torque.
- (6) Check if there is extreme unilateral engagement when it is in conjunction with the circular spline group. When unilateral migration occurs, it may be due to center deviation or skew of two parts.
- (7) when assembling the flex spline, please do not tap the gear front of the opening part or press with excessive force.

4. Other attentions:

- (1) The reducer must be installed in a sufficiently clean environment, and no foreign matter shall enter the reducer during installation to avoid damage during use.
- (2) Please ensure that the gear surface and flexible bearing of the reducer are always fully lubricated. It is not recommended to use the tooth face up all the time, which will affect the lubrication effect.
- (3) After installing the wave generator, please check the engagement between the flex spline and circular spline is 180° symmetrical (FIG. 1). For example, deviation to the side (FIG. 2) will cause abnormal vibration and quickly damage the flexible wheel.
- (4) After the installation is completed, please run at a low speed (100rpm). If there is abnormal vibration or abnormal sound, please stop immediately, and re-check whether the installation is correct or contact our company, so as to avoid damage to the reducer caused by improper installation.

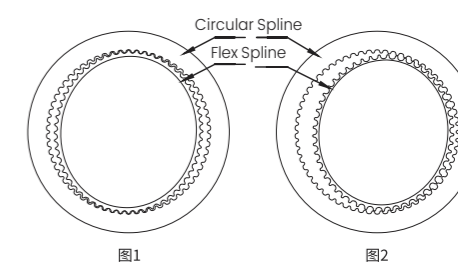

Assembly Method

1.WCSG Installation (circular spline fixed, flex spline output)

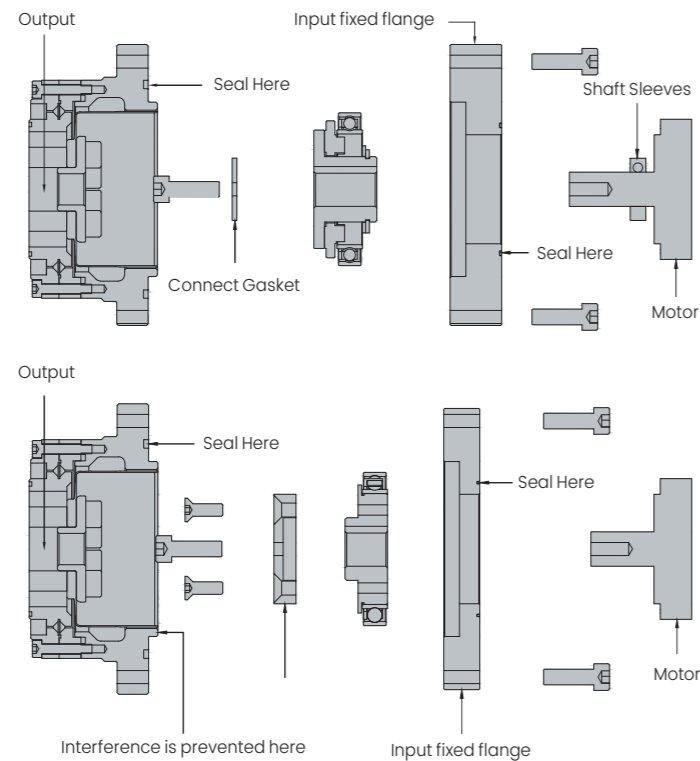

1. Apply the grease evenly on the flexible bearing, and fill the cavity connected with the fixed flange and the motor with the grease (please use the specified grease, do not replace the grease randomly to avoid damage to the reducer). Install the wave generator on the motor shaft or connecting shaft of the input end, and fix it with screw and flat gasket or connecting end cover.

2. Apply the grease evenly on the flexible spine, and fill flex spline with the grease. The injection volume is approximately 80% of the cavity volume (please use the specified grease, do not replace the grease randomly to avoid damage to the reducer). Install the reducer according to the diagram. When installing, the long axis of the wave generator is aligned to the direction of the long axis of the reducer's flex spline. When in place, the reducer is fixed with the corresponding screw. The pre-tightening force of the screw is 0.5Nm.

3. Set the motor speed at about 100 rotations per minute, start the motor, and the screws shall be locked by means of crisscross for four to five times to increase the locking force of the screws equally. (for screw locking force, see page 96) all fixed screws shall be of grade 12.9 and shall be coated with Loctite 243 thread adhesive to prevent screw failure or loose during operation.

4. processing requirement for mounting surface that connected with reducer: flatness 0.01mm, vertical axis 0.01mm.

Note:

When the reducer is in use, if the output end is always horizontally facing down (it is not recommended to use in this way), please contact us if the lubricating oil injected into the inner wall of the flex spline exceeds the meshing tooth surface. Please use the specified lubricating grease, do not change the grease at will to avoid damage to the reducer. Static sealing shall be adopted between the circular spline of reducer and the installation plane of input end to ensure the grease will not leak during the use of reducer and avoid the damage of reducer when it works with little or no oil.

2.WSHG-I/II Installation (1) (circular spline fixed, flex spline output)

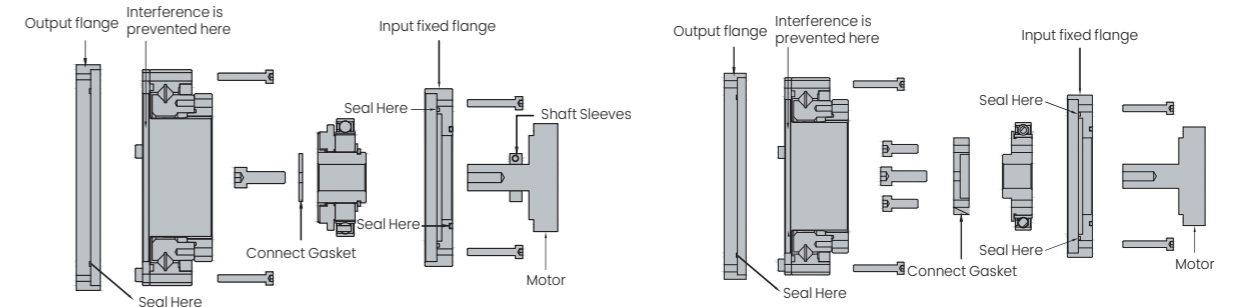

1. Apply the grease evenly on the flexible bearing, and fill the cavity connected with the fixed flange and the motor with the grease (please use the specified grease, do not replace the grease randomly to avoid damage to the reducer). Install the wave generator on the motor shaft or connecting shaft of the input end, and fix it with screw and flat gasket or connecting end cover.

2. Install the reducer according to the diagram. When installing, the long axis of the wave generator is aligned to the direction of the long axis of the reducer's flex spline. When in place, the reducer is fixed with the corresponding screw. The pre-tightening force of the screw is 0.5Nm.

3. Set the motor speed at about 100 rotations per minute, start the motor, and the screws shall be locked by means of crisscross for four to five times to increase the locking force of the screws equally. (for screw locking force, see page 96) all fixed screws shall be of grade 12.9 and shall be coated with Loctite 243 thread adhesive to prevent screw failure or loose during operation.

4. Apply a layer of grease evenly on the inner wall of the flexible pulley, and then inject the grease into the cavity of the flexible pulley. The injection amount is about 80% of the cavity of the flexible pulley.

5. The output end is also fixed according to step 3. All fixed screws shall be grade 12.9 and coated with Loctite 243 thread adhesive to prevent screw failure or loose during operation.

6. Machining requirements for installation plane fixed with reducer: plane degree 0.01mm, and axis perpendicular 0.01mm

Note:

When the reducer is in use, if the output end is always horizontally facing down (it is not recommended to use in this way), please contact us if the lubricating oil injected into the inner wall of the flex spline exceeds the meshing tooth surface. Please use the specified lubricating grease, do not change the grease at will to avoid damage to the reducer. Static sealing shall be adopted between the circular spline of reducer and the installation plane of input end to ensure the grease will not leak during the use of reducer and avoid the damage of reducer when it works with little or no oil.

3.WSHG-I/II Installation (2) (Flex spline fixed, circular spline output)

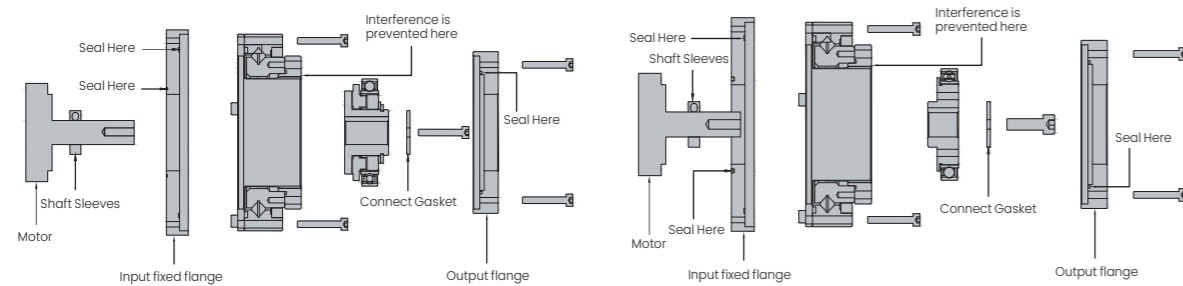

- 1.The reducer is installed at the input end and fixed with the corresponding screw. The screw pretightening force is 0.5Nm.
- 2.First, evenly apply a layer of grease on the inner wall of the flex spline, and then inject grease at the space B of the flex spline with an injection amount of about 80% of the cavity of the flex spline (please use the specified lubricating grease, and do not replace the grease at will to avoid damage to the reducer).
- 3.Install the reducer according to the diagram. When installing, the wave generator long axis aligned with the long axis of the flex spline, after installing in place, turn the wave generator, make the key on the CAM and the key on the input shaft alignment, install the key (key coated with Loctite 638 glue), with a screw plus large gasket to fix the wave generator on the shaft.
- 4.Apply grease uniformly on the flexible bearing and fill the cavity of A with grease (please use the specified lubricating grease and do not change grease at will to avoid damage to the reducer)
- 5.Set the motor speed at about 100 RPM, start the motor, and tighten the screws crossingly for four to five times with equal increase to the locking force corresponding to the screw. (The locking force for screws is shown on page 96.) All screws to be fastened shall be of grade 12.9 and coated with Loctite 243 thread adhesive to prevent failure or loose working
- 6.The output end is also fixed according to step 5.All fixing screws shall be of grade 12.9 and coated with Loctite 243 thread adhesive to prevent screw failure or loosening during operation.
- 7.Machining requirements for installation plane fixed with reducer: plane degree 0.01mm, and axis perpendicular 0.01mm.

Note:

When the reducer is in use, if the output end is always horizontally facing down (it is not recommended to use in this way), please contact us if the lubricating oil injected into the inner wall of the flex spline exceeds the meshing tooth surface. Please use the specified lubricating grease, do not change the grease at will to avoid damage to the reducer. Static sealing shall be adopted between the circular spline of reducer and the installation plane of input end to ensure the grease will not leak during the use of reducer and avoid the damage of reducer when it works with little or no oil.

4.WSHG-III Installation (3) (4) (Flex spline fixed, circular spline output)

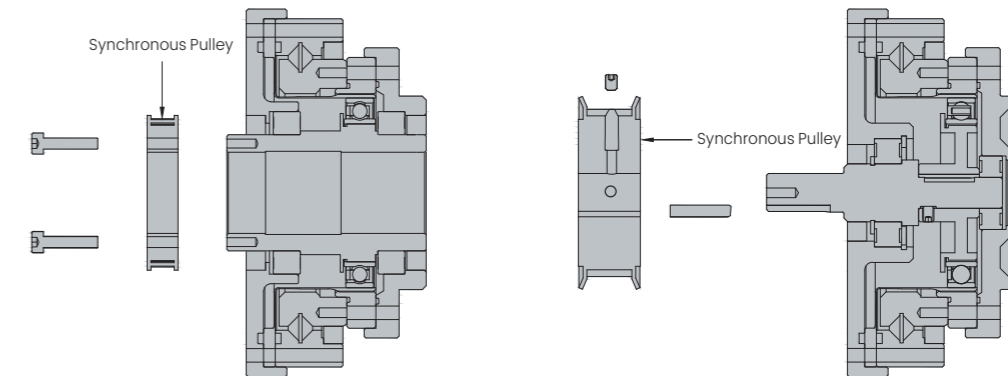

The reducer mount way when the motor shaft is smooth shaft

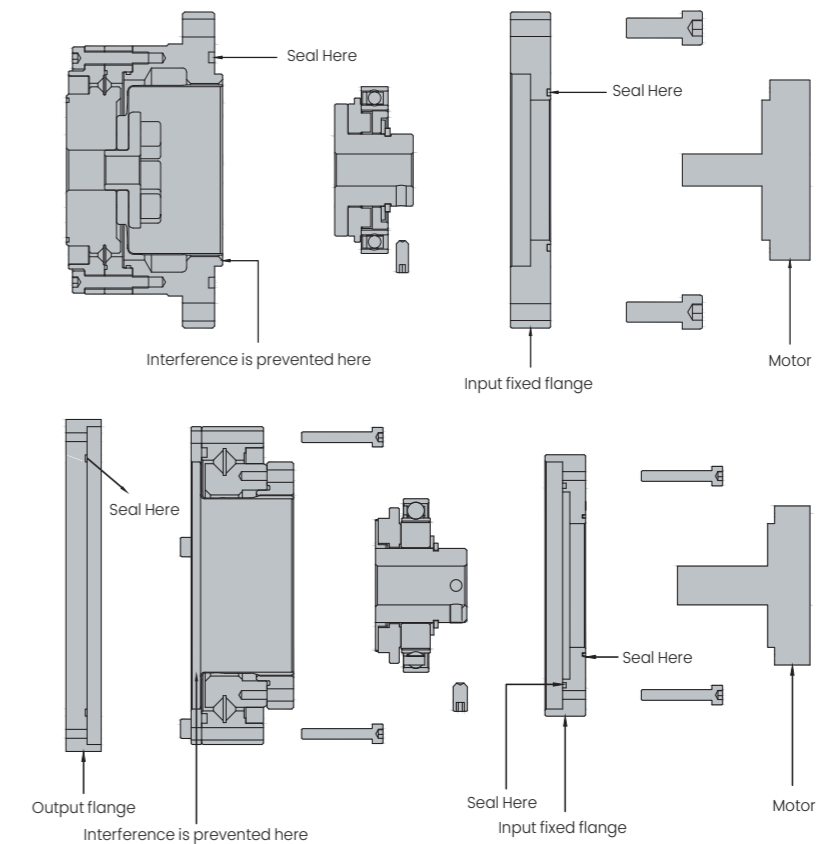

Screw locking method

1.Set motor speed at 100 rpm, and start motor. The screws are locked in crisscross manner. Try 4 to 5 times increased by degrees until it reaches corresponding locking force (see chart below).

2.Mounting plane processing requirements prescribed by connecting reducer: flatness 0.01mm, Screw locking method.

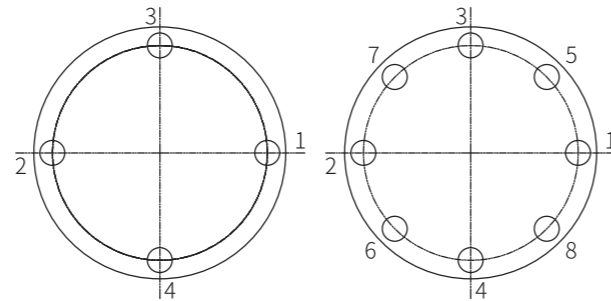

Screws correspond to locking force

		12.9						
Screw Nominal Diameter	mm	3	4	5	6	8	10	12
Locking Torque	N·m	2	4	9	15	35	70	125

Installation accuracy of reducer

I.Motor installation

Flange for motor installation: when the motor is installed on the combined type, the motor installation flange must be used for installation. The civil construction size and schedule of the flange base components for motor installation are shown in the following figure and table.

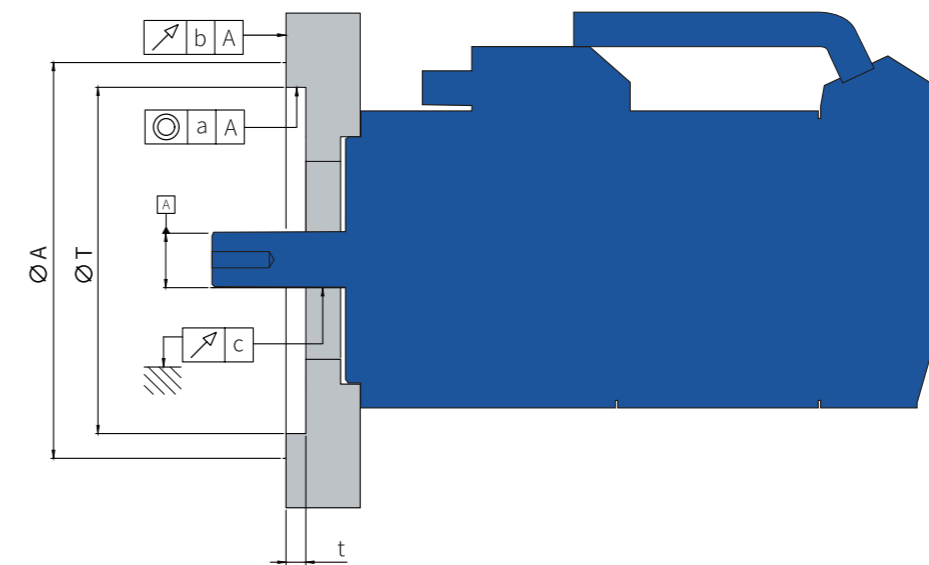

Unit:mm

Model Symbol	14	17	20	25	32
a	0.03	0.04	0.04	0.04	0.04
b	0.03	0.04	0.04	0.04	0.04
c	0.015	0.015	0.018	0.018	0.018
ØA	73	79	93	107	138
t	3	3	4.5	4.5	4.5
ØT	38H7	48H7	56H7	67H7	90H7

2.WCSG (F) - II Series assembly precision

Flange for motor installation: when installing the motor to the combined type, the motor mounting flange must be used for installation. Please refer to the following table and figure for mounting dimensions and precision of flange base components for motor installation.

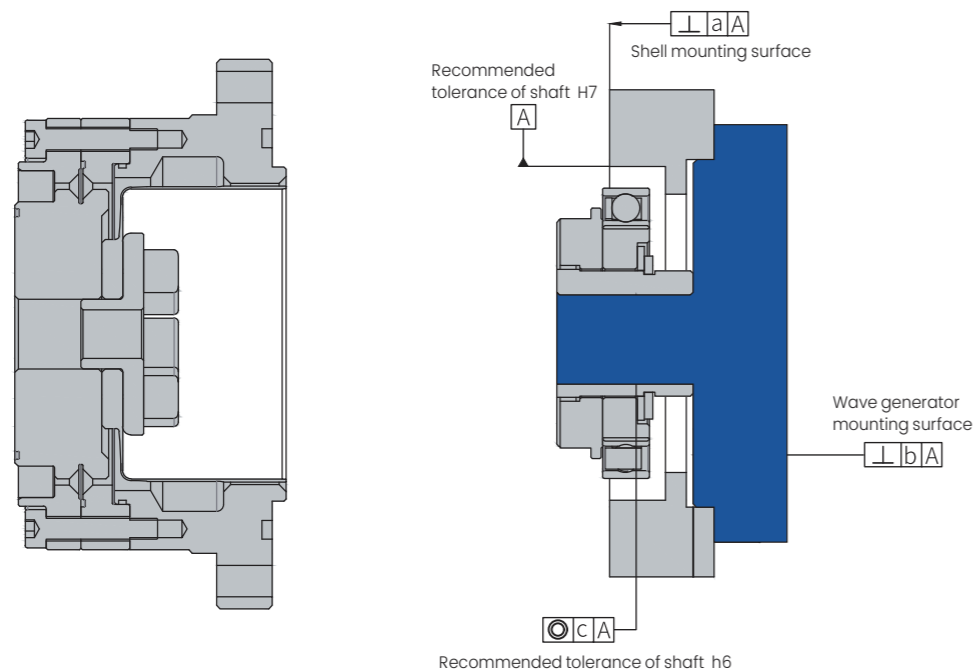

Unit:mm

Model Symbol	14	17	20	25	32
a	0.011	0.015	0.017	0.024	0.026
b	0.017	0.020	0.020	0.024	0.024
	(0.008)	(0.010)	(0.010)	(0.012)	(0.012)
c	0.030	0.034	0.044	0.047	0.050
	(0.016)	(0.018)	(0.019)	(0.022)	(0.022)

The values in () are those when the input unit (wave generator) is integrated structure.
(When European coupling structure is not used)

WCSD- I Series assembly precision

During assembly design, if there are abnormalities such as deformation of the mounting surface, or reluctant assembly, the product performance will be reduced. In order to give full play to the excellent performance of reducer, please pay attention to the following points and ensure to use the recommended precision of the assembled casing shown in the following picture and table.

- 1.The mounting surface is skewed and deformed
- 2.Foreign matter engaged-in
- 3.Burrs, bulges, and abnormal positions around the screw holes of the mounting holes
- 4.Insufficient chamfering of mounting concave round part
- 5.The roundness of the mounting concave round part is abnormal

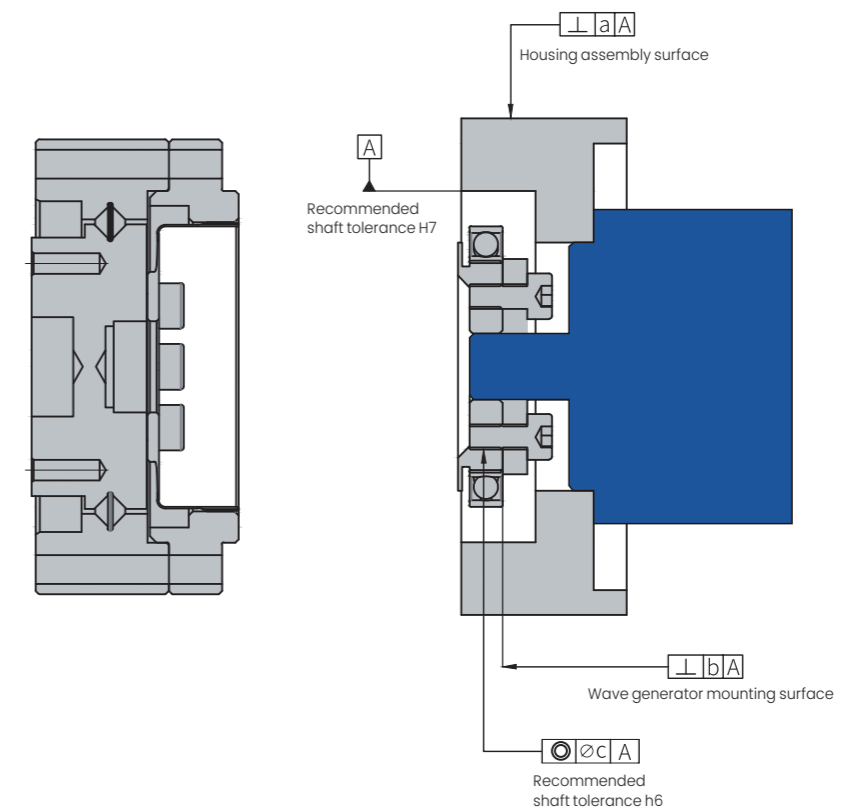

Unit:mm

Model Symbol	14	17	20	25	32
a	0.011	0.015	0.017	0.024	0.026
b	0.008	0.010	0.012	0.012	0.012
øc	0.016	0.018	0.019	0.022	0.022

WSHG(F) -II series assembly precision

During assembly design, to insure that harmonic reducer in use with optimal performance, please insure that using the recommend precision of assemble housing as shown below. (see chart below).

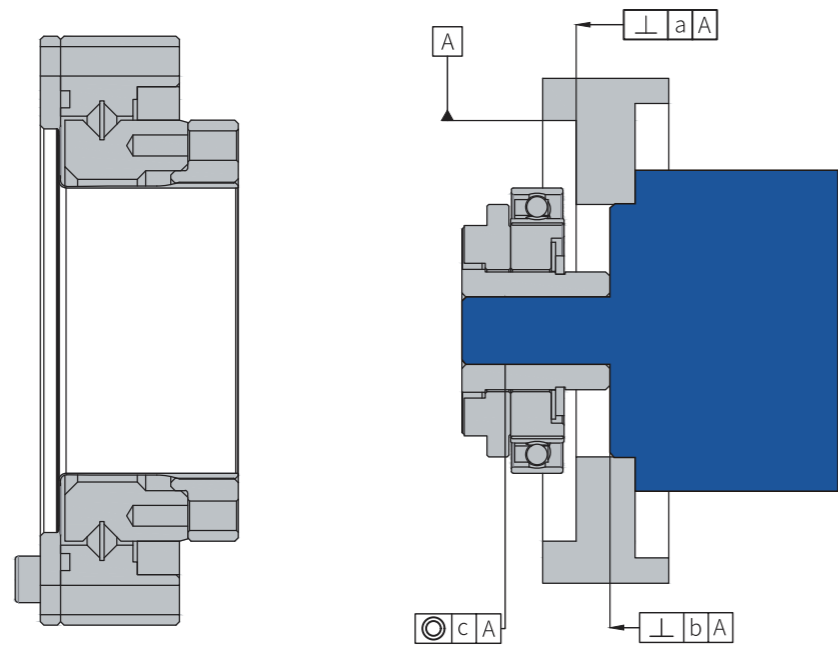

Unit:mm

Model Symbol	14	17	20	25	32
a	0.011	0.015	0.017	0.024	0.026
b	0.017	0.020	0.020	0.024	0.024
	(0.008)	(0.010)	(0.010)	(0.012)	(0.012)
c	0.030	0.034	0.044	0.047	0.050
	(0.016)	(0.018)	(0.019)	(0.022)	(0.022)

Value in () is the numerical values when input unit(wave generator) is one-piece structure (unused European coupling structure)

WSHD-I(II) series assembly precision

During assembly design, product performance will be reduced if there is abnormal situation, such as deformation of mounting surface. Assembled reluctantly will decrease product performance as well.

To insure that harmonic reducer in use with optimal performance, please pay attention to the following points, and insure that using the recommend precision of assemble housing as shown below. (see chart below).

- 1.Deflection and distortion about assembled surface
- 2.Foreign body embedding
- 3.Screw hole of mounting hole appears burr around, bulge, and abnormal position
- 4.The chamfering concave part is insufficient
- 5.The roundness of installation concave part is abnormal

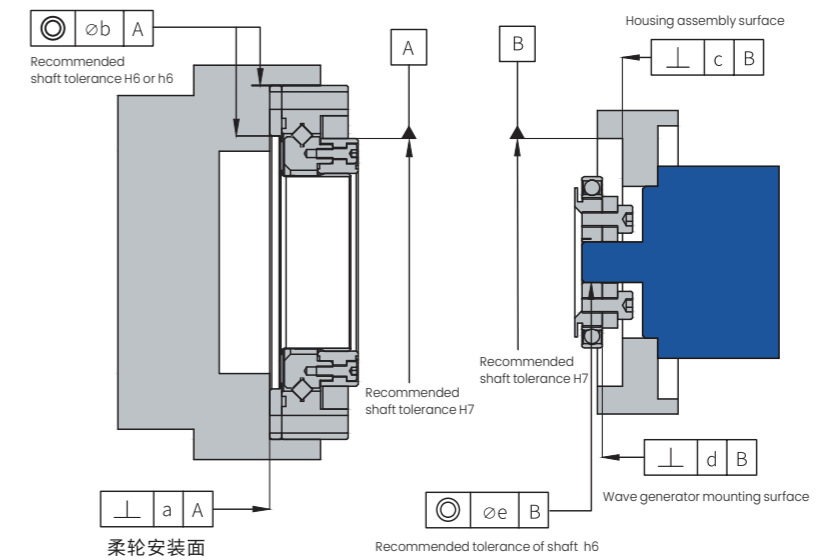

Unit:mm

Model Symbol	14	17	20	25	32
a	0.016	0.021	0.027	0.035	0.042
øb	0.015	0.018	0.019	0.022	0.022
c	0.011	0.012	0.013	0.014	0.016
d	0.008	0.010	0.012	0.012	0.012
øe	0.016	0.018	0.019	0.022	0.022

Application area



Robots



Armarium

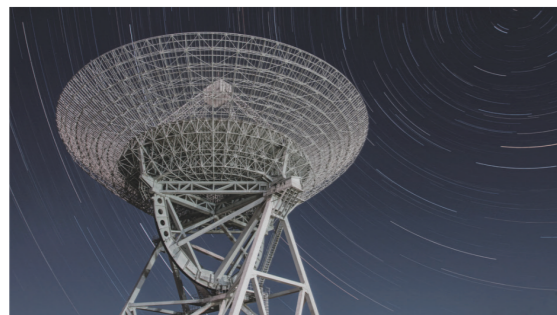

Communication equipment



Machine tool



Detection and analysis equipment



Printing equipment



Aerospace area



Semiconductor processing equipment

Grease Usage

Precautions Grease Usage

1. The internal hidden parts of the cup-shaped combined and hat-shaped hollow combined reducer before delivery have been sealed into the grease, but the grease needs to be injected and applied when assembling the wave generator.
2. The input and output end of harmonic reducer must be designed with strict sealing structure. Skeleton oil seal is recommended for dynamic sealing. O-ring or sealant is recommended for static sealing and the sealing surface must not be skewed or damaged.
3. Use the recommended semi-fluid grease for the reducer, and avoid mixing with other greases.
4. The use of grease must be carried out in accordance with the requirements of the instruction. Please note that the amount of grease injected and applied is different in different models.
5. In the use of reducer, if the wave generator is always in the state of facing up, may cause poor lubrication, at this time should increase the amount of grease injection or consult our company.
6. The performance of the grease will change with the temperature, and the higher the temperature, the faster the deterioration. In order to ensure the grease is always in good condition, the heat balance temperature at the high temperature end of the reducer should be lower than 70°C, and the temperature rise should be less than 40°C.
7. The wear of the moving parts of the reducer is mainly affected by the performance of the grease. Under the condition of conditions, the reducer should be replaced with the grease every 3000 hours.

Precautions Grease Usage

WCSG, WSHG series apply grease as per the following table

Amount of grease applied

Unit: g

Size	Grease area					D
	A	B	C			
			Horizontal use	Vertical use		
			Upward	Down		
14	0.3	0.3	6	8	9	0.3
17	0.5	0.5	10	12	14	0.5
20	0.8	0.8	16	18	21	0.8
25	1.5	1.5	30	35	40	1.5
32	3	3	60	70	80	3

Grease area

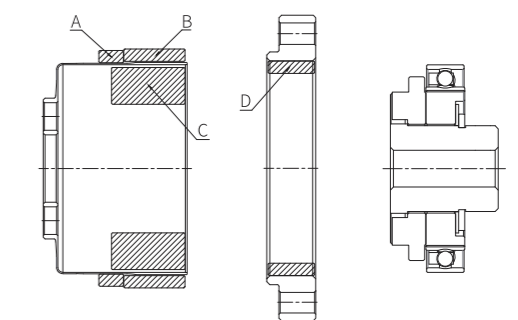

WCSG-1 series

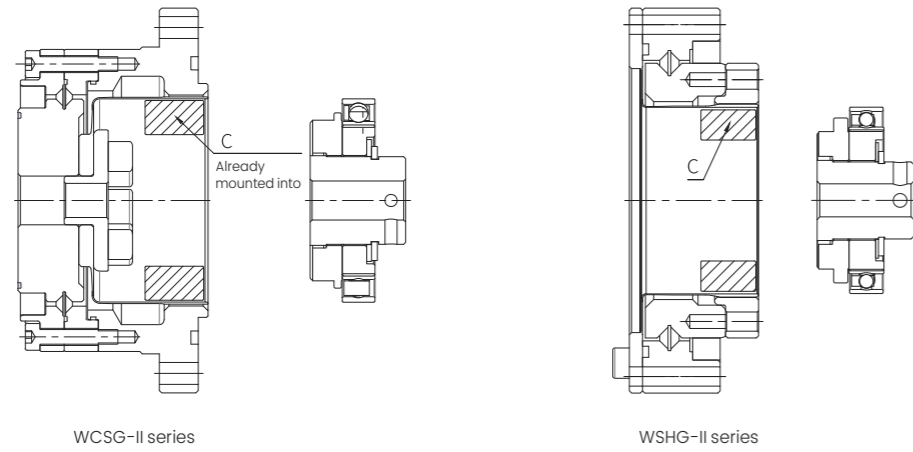

Pls. apply the grease for WSHG-III Series according to the following requirements

Amount of grease applied

Size	Grease area	
	C1	
14	5.5	
17	9.6	
20	10.3	
25	16	
32	26	

Grease area

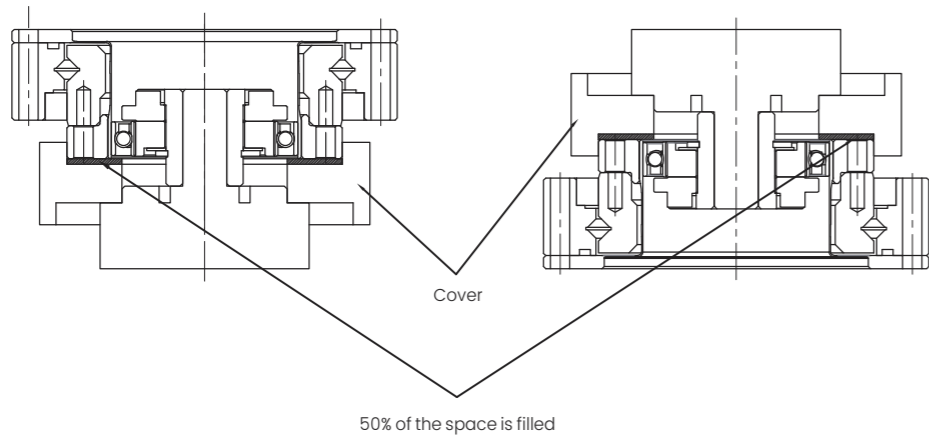
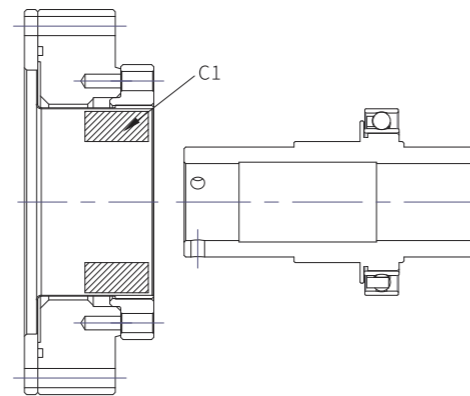

Pls. apply the grease for WSHD and WCSD Series according to the following requirements

Amount of grease applied

Size	Grease area		
	C		
	Horizontal use	Vertical use	
Upward		Down	
14	3	4	5
17	5	6	7
20	8	9	11
25	16	19	21
32	36	42	48

Unit: g

Grease area

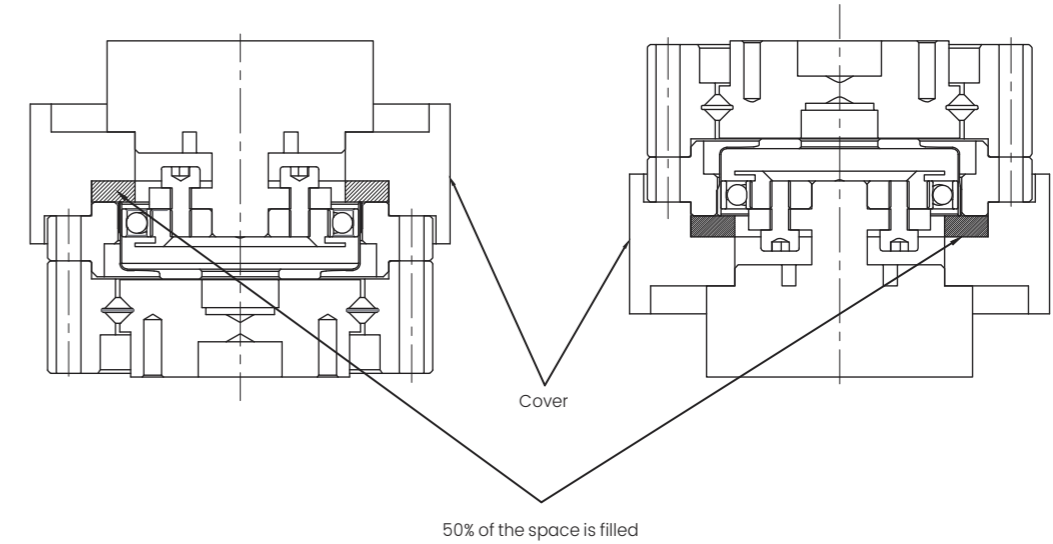
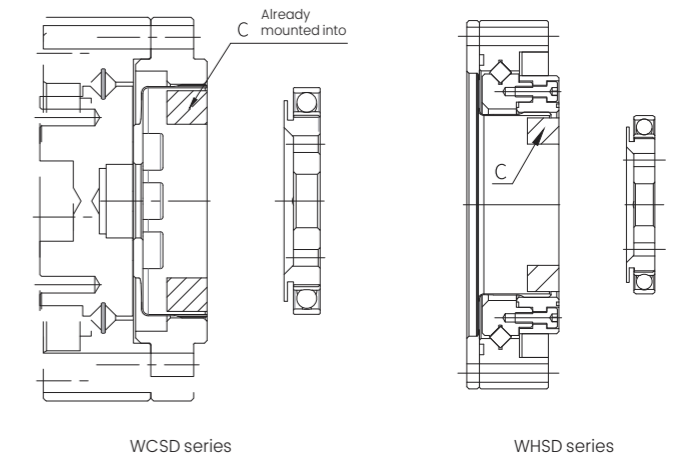

Grease Change Time

The abrasion of the moving parts of reducer is greatly affected by the performance of the grease. The performance of the grease will change according to the temperature, the higher the temperature, the faster the deterioration, so it is necessary to change the grease. As shown in the figure below, when the average load torque is lower than the rated torque, the replacement time benchmark of the grease can be determined according to the relationship between the grease temperature and the total revolutions of the wave generator. When the average load torque exceeds the rated torque, the grease replacement time benchmark is calculated by the following formula.

$$L_{GT} = L_{GTn} \times \left(\frac{T_r}{T_{av}} \right)^3$$

The formula for calculating when the average load torque exceeds the rated torque

L_{GT}	Change time beyond rated torque	Speed	—
L_{GTn}	Change time below rated torque	Speed	Refer to the figure below
T_r	The rated torque	Nm, kgfm	Refer to each series "parameter table"
T_{av}	Average load torque on the output side	—	Depending on the use condition

The sign of the formula

Grease change time: L_{GTn}
(when average load torque is lower than rated torque)

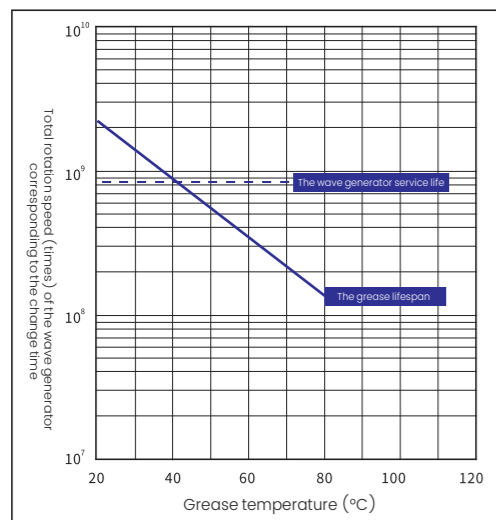

※ The service life of the wave generator indicates that the failure rate is 10%

Other notes:

1. Avoid mixing with other greases. In addition, when assembling to the device, please place the reducer in a separate housing.
2. When the wave generator is in an upward-facing state and rotating in a single direction at a low speed with a fixed load (input speed: less than 1000r/min), the use of reducer may cause poor lubrication, please consult Wanshsin.
3. Grease leakage for combined type. Although the combined type has been designed and constructed in response to grease leakage measures, but according to the use of the environment for sealing mechanism strengthening.

Warranty

WANSHSIN harmonic reducer warranty period and warranty scope is as follows:

Warranty Period

On the condition under normal assembly and lubrication state recorded in the product operation manual,

The warranty period is either one year or the product runs up to 8,000 hours.

Warranty Scope

Wanshsin is responsible for the repair or replacement of the product in case of failure caused by the manufacturing defects.

But the followings are not covered:

- (1) failure is caused by improper operation or illegal use.
- (2) failure is not caused by transformation or repair not by Wanshsin
- (3) failure not caused by the product.
- (4) Wanshsin is not responsible for the failure caused by natural disasters.

Moreover, the warranty here refers to the warranty of this product.

The company shall not be responsible for other losses caused by the failure of the product, the man-hours and expenses related to disassembling and assembling the equipment, etc.

Precautions for safety use

 **Warning** Error in operation may result in death or serious injury.

 **Attention** Indicates that the wrong operation may result in injuries and property damage.

About the scrap

 **Attention** Please treat according to industrial waste standard.
Note: when scrapping, please treat as industrial waste.

Design attentions (be sure to read the instructions when designing)

 Attention	<p>Please use under regulated conditions</p> <p>When using reducer, please comply with the following conditions.</p> <ol style="list-style-type: none"> 1. Ambient temperature: 0~40°C. 2. Do not splash water, oil, etc. 3. Non-corrosive, explosive gas. 4. No dust such as metal powder. 	<p>please install according to the specified precision</p> <ol style="list-style-type: none"> 1. Assembly method, order, please follow the product catalog. 2. Tightening method (using bolts, etc.), please follow our advice. 3. If not assembled correctly, the operation may lead to vibration, shorten the service life, precision decline, damage and other faults.
	<p>please install according to the specified precision</p> <ol style="list-style-type: none"> 1. Please design and assemble various parts correctly to ensure that they can meet the installation precision recommended in the product catalog. 2. Failure to meet the specified precision may lead to vibration, shorten service life, precision decline, damage and other faults. 	<p>Please use the specified grease</p> <ol style="list-style-type: none"> 1. Do not use the grease recommended by Wanshsin may shorten the service life of the product. In addition, please change the grease according to the specified conditions. 2. The combined product has been pre-sealed with grease. Please do not mix with other greases.

Notes for use (please be sure to read the manual when running)

 Attention	<p>Please handle the products and components with care</p> <ol style="list-style-type: none"> 1. Do not use a hammer and other hard hit each component and combination unit. In addition, please make sure that there are no cracks, dents, etc. caused by falling, etc. Otherwise, the product will be damaged. 2. Performance cannot be guaranteed when used in a damaged state. It may also cause damage and other faults. 	<p>When in use, do not exceed the allowable torque</p> <ol style="list-style-type: none"> 1. Apply torque do not exceed the maximum allowable torque of the moment. Otherwise the bolts in the tightening part may become loose, shake, and damage, leading to product failure. 2. If the output shaft is directly connected to the joint arm, it may be damaged due to the joint arm collision, the output shaft cannot be controlled.
	<p>Do not change spare parts</p> <ol style="list-style-type: none"> 1. The parts of the product are made of matching processing. When used in conjunction with other suites, there is no guarantee that a particular performance will be achieved. 	<p>Do not disassemble the combined product</p> <ol style="list-style-type: none"> 1. It is strictly prohibited to disassemble and reassemble combined products. Otherwise its original performance will not be restored.

Use of grease

 **Warning**

stallation precautions

1. Splashing into the eye may cause inflammation. When operating, please wear protective glasses to avoid splashing into the eyes.
2. Skin contact may cause inflammation. When operating, please wear protective gloves to avoid contact with the skin.
3. Do not swallow (can cause diarrhea, vomiting, etc.).
4. Be careful not to cut your finger when opening the container, please wear protective gloves.
5. Please keep it out of reach of children.

Emergency Treatment

1. In case of splash into the eyes, rinse immediately with water for 15 minutes and receive medical treatment.
2. In case of contact with skin, wash thoroughly with water and soap.
3. If swallowed, do not force it to vomit, should immediately accept medical treatment.

 **Attention**

Storage Method

1. After use, please seal it to prevent dust, moisture and other mixed. Please keep it in the shade, away from direct sunlight.
2. For long-term inventory of products, it is recommended to confirm whether the performance and rust prevention is good.
3. Please refer to the delivery drawing for details of surface treatment.

Disposal of waste oil and waste containers

1. The decree provides a treatment that users are obliged to implement. Please handle it correctly according to relevant laws and regulations. If you are not clear, please consult Wanshsin.
2. Do not put pressure on empty containers, pressure may cause it to crack.
3. Do not weld, heat, open or cut the container, otherwise there could be an explosion and the remains inside could catch fire.