

HC Hy-Vo Inverted Tooth Chain Drives



For High Velocity, High Horsepower and High Efficiency Drives with smooth transmission of load in a compact space.

Morse HC Drives provide the Drive Designer with a new concept in the transmission of power for high speed, high load applications. Proven in a wide range of applications from high production automobiles to custom-designed flood control pumps, HC Drives offer opportunity for flexibility, compactness, weight saving and economy.

In the late 1940's Morse Chain Engineers developed the original design of HC to meet the high speed, high load requirements of Oil Well Drilling equipment. The first chain 2" Pitch x 12" Wide transmitted 1300kW at 650 r.p.m. on the slush pump of a drill rig. Success on this and similar applications led to the further development of a family of chains from $\frac{3}{8}$ " to 2" pitch which have been successfully applied to a wider variety of industrial applications including Roll Grinders, Dynamometers, Pump Drives, Gas Turbine Starters, four Square Test Rig, and many Automotive Transmissions. Further development of HC chain enables drives over 2,500kW being accommodated with standard chain widths.

HC Hy-Vo Chain Design

The Chain assembly consists of inverted tooth link plates, laced alternately and connected by two steel pins of the same cross sectional geometry, which form an articulating joint between the link sections.

HC Hy-Vo Link Plate Design

The link design in the original HC pitches - $\frac{3}{4}$ ", 1", $1\frac{1}{2}$ " and 2" (Fig 1) had been tested and proven for many years. The link crotch is located slightly above the line of pull and all corners are rounded to minimise the possibility of stress risers and to ensure maximum performance on high load industrial applications. The $\frac{3}{8}$ " and $\frac{1}{2}$ " pitch chains (Fig. 2) have a new link contour for increased speed requirements, with the link crotch below the line of pull, and this design is now extended to include $\frac{3}{4}$ " and 1" pitches. Photo-elastic studies of various link shapes and aperture positions produced the design with the lowest level of stress concentration. Improved metallurgy, and development in design and pressure angle, achieve maximum load capacity with high speed performance. Carefully controlled shot-peening of the links gives them a uniform, matt grey finish and results in an improved level of link fatigue resistance.

Concentric Pin and Rocker Joint

The joint consists of a pin and rocker of identical cross section and contact radii. When chain engages the sprocket teeth the curved surfaces roll on each other eliminating sliding friction, and joint galling. The radii of the pins is selected to give almost perfect pitch compensation to minimise chordal* action. Before engagement with the sprocket the contact point of pin and rocker is below pitch line (Fig. 3). When chain engages with the sprocket teeth, the contact point moves upwards (Fig. 4) with slight elongation of the pitch to wrap the sprocket along the pitch line.

Chordal Action

The compatible design of HC links, joints and sprockets reduces the detrimental effects of chordal action to a minimum. The chordal action of conventional chain drives is the vibratory motion caused by the rise and fall of the chain as it engages sprocket teeth. This motion causes vibration and limits high speed load carrying capability. Of all types of chains, HC operates most efficiently at all speeds because chordal action is reduced to a minimum.

Fig 5. shows how HC chain enters approximately tangent to the pitch circle of the sprocket and maintains this position as it travels around the sprocket. This smooth engagement permits high speed capabilities with efficiency and quietness.

Involute Tooth Sprocket

The third criteria for the success of HC is the mating sprockets. An involute tooth form, differing from the straight sided teeth of conventional silent chain sprockets is designed for smooth engagement of the chain with the sprocket teeth. All HC sprockets are top-hobbed and the teeth heat treated for tough wear resistant surface. Unlike the single tooth engagement of spur gears, many teeth share the load on a HC drive, resulting in low stresses, less wear, and long sprocket life.

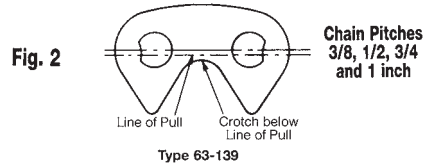
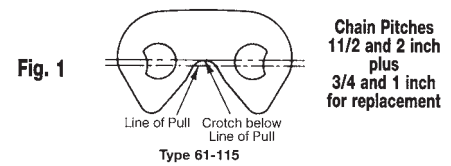

HC Chain Link Plates

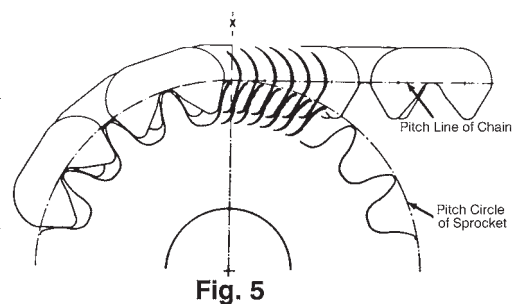
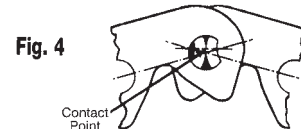
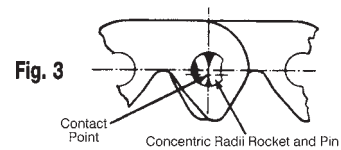

You get more with HC

The features of HC link design, compensating pin and rocker joint, with the involute hobbed sprockets means HC chain can transmit more power, at higher speeds, in less space than other transmission media, with smooth action and minimum of noise.

High Speed Performance Operating chain speeds range from 10 to 35 metres per sec. with higher speeds (to 55m/sec) on special applications.

High Power in Narrow Widths HC chain transmits more power per inch of width than any other chain or belt drive, with capacities up to 6000 kW.

Smooth Quiet Operation The rolling action of the chain joints combined with smooth sprocket engagement minimise induced vibrations. This enables HC chain to provide quiet drives on high speed applications.

High Efficiency Smooth operation, with minimal frictional losses, provide transmission efficiencies up to 99.7%.

HC Hy-Vo Chain - Selection



There are Seven good reasons to use HC in your design!

HC transfer cases provide weight and cost savings because:

1. *Fewer Shaft* and Bearings are required.
2. *Lighter Loads* on Shaft Bearings.
3. *Chain Bearing Loads* are compressive, placing case in compression, unlike gear forces which are tensile.
4. *HC Cases are Lighter* as compressive loads mean thinner sections can be used.
5. *Centre Distance is less Critical* and more flexible than required by gear and belt drives.
6. *Elasticity of HC Chain* accommodates normal thermal expansion, and helps 'cushion' the drive.
7. *Simplified Design* results in a positive cost saving.

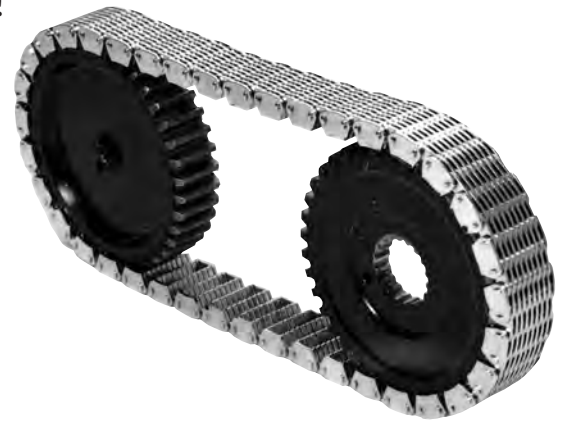

HC Drive Selection

Design of a HC Chain Drive involves correct selection of chain and sprockets combined with correct casing design and lubrication system. The Power Rating tables opposite, giving power ratings per inch width of chain, enable selection of chain with drives operating under ideal conditions of smooth power source and load. To use these tables for other drives involving shock loads the Actual Power must be modified by a Service Factor to obtain the Design Power which can then be related to the tables.

Service Factors - S.F.

Type of Load	Int. Comb. Eng. Hydraulic Drive	Electric Motor	Int. Comb. Eng. Mechanical Drive
Smooth	1.0	1.0	1.2
Moderate Shock	1.2	1.3	1.4
Heavy Shock	1.4	1.5	1.7

HC Drive Selection

1. Determine the R.P.M. and diameter of the high speed shaft.
2. Determine the total power to be transmitted.
3. From application detail determine proper service factor from table. Refer page 7 in Roller Chain Selection for machine types.
4. Establish Design Power by multiplying total Power to be transmitted by the service factor.

$$\text{Design Power kW} = \text{Motor Power} \times \text{S.F.}$$
5. Select the chain pitch and width and number of teeth in the small sprocket from the Power Rating Tables.
 - a. For quiet and smooth drives use sprockets 25 teeth or more.
 - b. Be sure the small sprocket will accommodate the high speed shaft diameter. As a guide with steel sprockets Pitch Circle Diameter should be minimum twice shaft diameter $\text{PCD} \geq \frac{Zp}{\pi}$
 - c. If the high speed shaft diameter exceeds the maximum bore in the selected small sprocket it will be necessary either to increase the number of teeth in the sprocket or select the next larger pitch chain.
6. Determine the required drive ratio:

$$\frac{\text{RPM high speed shaft:}}{\text{RPM slow speed shaft:}} = \text{Ratio}$$
7. Multiply the number of teeth in the small sprocket by the ratio to obtain the number of teeth in the large sprocket.
8. To determine chain length and centre distance refer to page 9. Centre distance and sprocket combination must always provide an even number of pitches of chain. For fixed centre drives it is recommended to use Centre Distance tables. HC drives should always be installed with a slight preload, and to provide this the actual centre distance is obtained by increasing the theoretical by 0.07%. Manufacturing tolerances should always be on the plus side. Further advice on centre distance requirements can be obtained from Cross+Morse Engineering.
9. As more than one pitch of chain could be selected for most applications consideration should be given that the shaft centre distance should never exceed 60 times pitch, and that large pitch, narrow width selections are better for shock loading and commercial considerations; however, small pitch chains operating on sprockets with high numbers of teeth give smoothest drives with minimum noise level. Whilst preliminary drive selection can be made from the tables it is recommended that all HC Drives be referred to Cross+Morse Engineering Department for final approval.
10. The design and manufacture of the sprockets is critical for correct drive operation. General dimensional details are provided on page 81. Sprockets with 35 teeth or less are best manufactured from low carbon alloy steels with teeth carburised and hardened. Larger sprockets can be manufactured from medium carbon steels or mechanite castings and induction or flame hardened. Teeth must be generated to the special involute form for smooth drive operation. For 1:1 drives it is preferable to use even tooth sprockets for smooth drive, but on all reduction drives it is best to use odd number teeth in small sprocket for maximum drive life. Idler sprockets should never be used. Cross+Morse can offer the full range of HC sprockets - manufactured to meet customers requirements. If not specified, through bore length, hub diameter and all manufacturing tolerances will be Morse Standards. Materials and Tooth hardness will always be to Morse Specification.

HC Hy-Vo Chain - Selection Tables (kW)



The tables below provide power ratings in kW for chains of 1" width. To obtain capacity of other widths multiply width (inches) by rating obtained from table. Whilst tables cover sprockets from 21 teeth, it is recommended to use a minimum of 25 teeth for maximum chain performance and life. Preliminary selection can be made with these tables, but it is recommended that all selections should be confirmed with Cross+Morse Engineering prior to implementation. For applications with powers and/or speeds outside tables, consult Cross+Morse Engineering.

3/8" Pitch - HC3 Chain Type 63-139

Stock Widths:
3/4", 1", 1 1/2", 2", 3"

No. Teeth	RPM														
	1500	2000	2500	3000	3500	4000	4500	5000	5500	6000	6500	7000	7500	8000	9000
21	19	25	31	37	42	48	53	58	62	66	70	73	76	78	80
23	21	27	34	40	46	52	57	62	66	70	74	77	79	80	81
25	22	29	36	43	50	56	61	66	70	74	77	79	80	81	
27	24	32	39	47	53	59	65	69	74	77	79	80	81		
29	26	34	42	50	56	62	68	72	76	79	80	81			
31	28	36	45	52	59	65	71	75	78	80					
35	31	41	50	58	65	71	76	79	80	81					
39	34	45	54	63	70	75	79	80							
45	39	51	61	69	76	80	81								

1/2" Pitch - HC4 Chain Type 63-139

Stock Widths:
1", 1 1/2", 2", 3", 4"

No. Teeth	RPM															
	1000	1250	1500	1750	2000	2500	3000	3500	4000	4500	5000	5500	6000	6500	7000	
21	26	32	39	45	51	63	74	85	95	104	112	119	125	129	132	
23	28	35	42	49	56	68	80	92	102	111	118	125	129	132	133	
25	30	38	46	53	60	74	86	98	109	117	125	129	132	133		
27	33	41	49	57	65	79	92	104	114	122	128	132	133			
29	35	44	53	61	69	84	97	109	119	126	131	133				
31	38	47	56	65	74	89	103	115	124	130	133					
35	43	53	63	72	82	98	112	123	130	133						
39	48	59	70	80	89	106	120	129	133							
45	54	67	79	89	100	117	128	133								

3/4" Pitch - HC6 Chain Type 63-139

Stock Widths:
1 1/2", 2", 3", 4", 5"

No. Teeth	RPM															
	600	900	1200	1500	1800	2100	2400	2700	3000	3300	3600	3900	4200	4500	4800	
21	33	48	64	79	94	107	120	132	143	153	161	168	172	176	177	
23	36	53	70	86	101	116	129	142	152	161	168	174	177	177	176	
25	39	57	75	93	110	125	138	150	160	168	174	177	177	177	170	
27	42	62	81	100	117	132	146	157	166	173	176	177	175			
29	45	66	86	106	124	139	153	164	171	177	177	175				
31	48	71	92	113	130	146	160	169	175	177	175					
35	54	79	103	124	143	158	169	176	177	173						
39	60	87	113	136	154	168	176	177								
45	69	99	127	150	166	177	175									

1" Pitch - HC8 Chain Type 63-139

Stock Widths:
2", 3", 4", 5", 6"

No. Teeth	RPM															
	600	800	1000	1200	1400	1600	1800	2000	2200	2400	2600	2800	3000	3300	3600	
21	54	72	89	105	121	136	150	163	174	185	195	202	208	214	215	
23	59	78	96	114	130	146	161	174	186	195	203	210	214	215	212	
25	64	84	104	123	140	156	171	184	195	204	210	214	215	212	200	
27	69	91	112	131	150	166	180	193	203	210	214	215	213	203		
29	74	97	119	139	159	175	189	200	209	214	215	213	206			
31	79	104	127	148	167	183	197	207	213	215	213					
35	89	116	140	163	182	197	208	214	215	210						
39	98	127	154	176	195	207	214	215	208							
45	112	145	171	193	208	215	213	200								

1 1/2" Pitch - HC12 Chain Type 61-115

Stock Widths:
3", 4", 5", 6"

No. Teeth	RPM															
	200	400	600	800	1000	1200	1400	1500	1600	1800	2000	2100	2200	2400	2500	
21	29	58	85	111	135	155	172	179	185	193	196	195	195	184	142	
23	32	63	93	121	144	165	181	187	191	196	194	190	183	151		
25	35	68	100	129	154	174	188	192	195	194	186	172				
27	37	73	107	138	162	182	193	195	196	189						
29	40	79	115	146	171	188	196	195	193	173						
31	43	84	121	153	177	193	196	192	186							
35	48	94	135	167	188	196	188	172								
39	53	104	147	178	195	192										
45	62	117	163	191	194											

2" Pitch - HC16 Chain Type 61-115

Stock Widths:
3", 4", 5", 6"

No. Teeth	RPM															
	200	300	400	500	600	700	800	900	1000	1100	1200	1300	1500	1700	1800	
21	47	70	92	114	134	153	170	186	199	210	219	224	226	215	203	
23	51	77	101	124	145	165	181	197	210	219	225	227	219	194		
25	56	83	109	134	155	175	193	207	218	225	227	225	205			
27	60	90	117	143	166	186	202	215	224	227	225	217	182			
29	65	95	124	151	175	195	210	222	227	226	219	204				
31	69	102	132	160	183	203	217	225	227	221	207					
35	78	114	147	175	199	216	225	227	218	198						
39	86	125	160	189	211	224	227	217	195							
45	98	142	179	207	224	227	213	182								

It is essential that drives selected in the area right of the tinted area are fitted with a pressure fed spray lubrication system. Other drives can operate in oil bath lubrication.

Note: Other widths of chain up to 8 times pitch can be supplied to order.

HC Hy-Vo Chain Dimensions

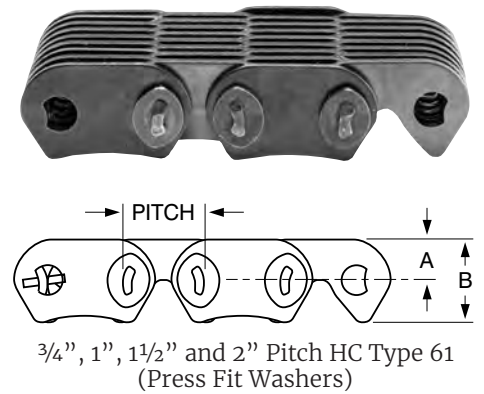
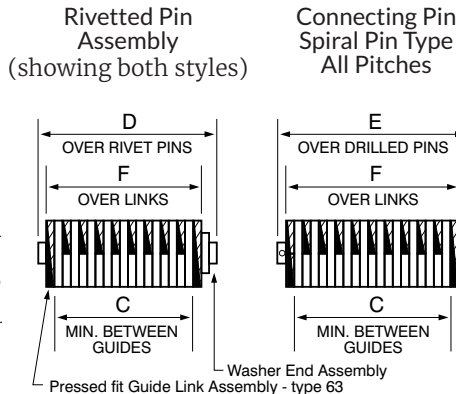
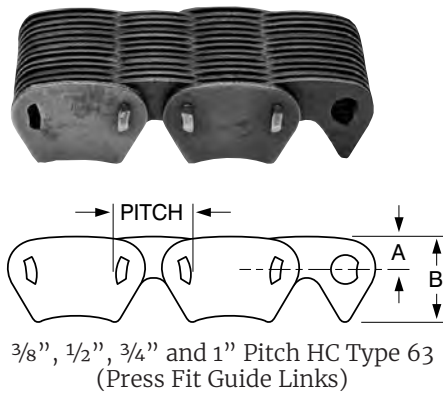

Chain Dimensions

HC Chain Designation	Nominal Width Inches	Chain Pitch ins (mm)	Chain Height above Splt. PCD A mm	Chain Height B mm	Min Width between Guides C mm	Width over Links F mm	Width over Rivet Pin D mm	Width over Drilled Pins E mm	Average U.T.S. kN	Ave. Weight per Metre kg
3/8" PITCH 63 type										
HC-303	3/4				17.4	20.6	22.7	26.1	25	1.0
HC-304	1				23.8	26.9	29.1	32.5	33	1.3
HC-305	1.1/4	3/8"	4.3	10.9	30.2	33.5	35.5	38.9	42	1.6
HC-306	1.1/2	(9.525)			36.6	39.7	41.9	45.3	50	1.9
HC-308	2				49.4	52.5	54.7	58.1	67	2.6
HC-312	3				74.8	77.9	80.1	83.5	100	3.9
1/2" PITCH 63 type										
HC-403	3/4				17.4	20.6	22.7	26.1	33	1.3
HC-404	1				23.8	26.9	29.1	32.5	44	1.7
HC-405	1.1/4	1/2"	5.7	14.5	30.2	33.5	35.5	38.9	55	1.3
HC-406	1.1/2	(12.70)			36.6	39.7	41.9	45.3	67	2.6
HC-408	2				49.4	52.5	54.7	58.1	89	3.4
HC-410	2.1/2				62.1	65.3	67.4	70.8	111	4.3
HC-412	3				74.8	77.9	80.1	83.5	133	5.1
HC-416	4				100.2	103.4	105.5	108.9	178	6.8
3/4" PITCH 63 type										
HC-606/139	1.1/2				36.3	40.5	43.3	47.4	100	4.0
HC-608/139	2				49.0	53.2	56.0	60.1	133	5.3
HC-612/139	3	3/4"	9.8	21.7	74.4	78.6	81.4	85.5	200	7.9
HC-616/139	4	(19.05)			99.8	104.0	106.8	110.9	267	10.5
HC-620/139	5				125.2	129.4	132.2	136.3	334	13.0
HC-624/139	6				150.6	154.8	156.6	161.7	400	15.6
1" PITCH 63 type										
HC-808/139	2				48.0	54.2	58.1	64.7	178	7.1
HC-812/139	3	1"			73.4	79.6	83.5	90.1	267	10.5
HC-816/139	4	(25.40)	11.4	29.0	98.8	105.0	108.9	115.5	356	13.9
HC-820/139	5				124.2	130.4	134.3	140.9	445	17.4
HC-824/139	6				149.6	155.8	159.7	166.3	534	20.8
3/4" PITCH 61 type										
HC-606	1.1/2				31.7	35.9	43.2	43.4	100	3.9
HC-608	2				44.4	48.6	55.9	56.1	133	5.2
HC-612	3	3/4"	10.3	20.9	69.8	74.0	81.3	81.5	200	7.7
HC-616	4	(19.05)			95.2	99.4	106.7	106.9	267	10.3
HC-620	5				120.6	124.8	132.1	132.3	334	12.8
HC-624	6				146.0	150.2	156.5	156.7	400	15.3
1" PITCH 61 type										
HC-808	2				41.2	47.4	56.8	57.7	178	6.8
HC-812	3	1"			66.6	72.8	82.2	83.1	267	10.3
HC-816	4	(25.40)	13.7	27.8	92.0	98.2	107.6	108.5	356	13.7
HC-820	5				117.4	123.6	133.0	133.9	445	17.1
HC-824	6				142.8	149.0	158.4	159.3	534	20.5
1 1/2" PITCH 61 type										
HC-1212	3				66.6	72.8	89.2	85.2	400	15.5
HC-1216	4	1 1/2"			92.0	98.2	109.6	110.6	534	20.5
HC-1220	5	(38.10)	20.6	41.8	117.4	123.6	135.0	136.0	667	25.7
HC-1224	6				142.8	149.0	160.4	161.4	801	30.8
HC-1232	8				168.2	174.4	185.8	186.8	1067	35.9
2" PITCH 61 type										
HC-1612	3				63.7	72.0	86.4	87.0	534	20.5
HC-1616	4	2"			89.1	97.4	111.8	112.4	712	27.4
HC-1620	5	(50.80)	27.4	55.7	114.5	122.8	137.2	137.8	890	34.2
HC-1624	6				139.9	148.2	162.6	163.2	1068	41.1
HC-1632	8				190.7	199.0	213.4	214.0	1424	47.9

The design of the HC6 and HC8 chains was improved in 1994 to 63 type to provide increased power capacity. Chains to the original design remain in production to provide replacements on earlier machinery. For new designs type 63 chains provides a more compact and economical installation. When ordering the 63 type chains please add the suffix /139 to the part number, as in above table, to ensure correct chains are supplied. HC6 and HC8 chains ordered without the suffix will be supplied as 61 type. Note that 63 type chains cannot run on sprockets cut for 61 type. Offset (Crank) Links are not available for HC series chains, thus all chain lengths must be of even number of pitches. Chains up to 1 inch pitch are normally stocked in 10 foot boxed lengths, but chains can also be supplied to a specific length, with either a cottered Connecting Link, or as rivetted endless construction. Other configurations and widths of HC chains can be supplied to special order, including centre guide chains, and for vertical shaft applications chains with multiple guides to provide additional support on the sprockets.

HC Hy-Vo Chain Sprocket Dimensions



HC Sprockets

Cross+Morse can provide a full range of HC Sprockets manufactured in the best combination of materials and heat treatment to ensure long service life with ability to transmit full designed torques and powers with minimum noise and vibration.

Sprockets up to 30 teeth and below are usually manufactured from low carbon alloy steels with teeth carburised and sprockets hardened to provide maximum wear resistance with high core strength, larger sprockets are produced in medium carbon steel with induction hardened teeth, or meehanite castings.

It is recommended that a minimum 25 tooth sprockets be used in all drives to provide best efficiency, smooth transmission and low noise levels, however, all sizes of chain can operate on sprockets down to 19 teeth, but such drive designs should always be referred to Cross+Morse. It is preferred practice to use sprockets with odd numbers of teeth, but for 1:1 ratio even teeth sprockets should always be used for optimum chain life and performance.

Sprocket Dimensions

Detailed dimensions for all sizes of Sprockets can be supplied on request, these including blank dimensions and material specification, if customers wish to supply their own blanks for tooth cutting only. The Sprocket design information provided here can be used for initial design and selection.

Sprocket Face Widths, Groove Dimensions, and Maximum Hub

Chain width Inches	Chain Pitch Size							
	HC3	HC4	HC6/139	HC8/139	HC6	HC8	HC12	HC16
Face Width for Side Guide and Vertical Shaft Chains								
16.76	16.76							
22.86	22.86							
29.21	29.21							
35.56	35.56	33.53		29.72				
48.26	48.26	46.23	44.45	42.16	38.10			
73.66	73.66	71.63	69.85	67.56	63.50	63.50	59.44	
99.06	99.06	97.03	95.25	92.56	88.90	88.90	84.84	
		122.43	120.65	118.56	114.30	114.30	110.24	
		147.83	146.05	143.76	139.70	139.70	135.64	
			196.85	190.50	190.50	190.50	186.44	
Factors for Common Dimensions								
d	8.5	11.0	16.5	22.0	13.5	18.0	27.0	36.0
g	3.0	3.0	4.0	6.0	4.0	6.0	6.0	8.0
y	16.5	21.5	32.6	43.5	27.0	36.5	53.8	72.0

Pitch Circle Diameter and Maximum Shaft Size

$$PCD = \frac{PN}{\pi} \secant \frac{180^\circ}{N}$$

where N = No. of teeth in Sprocket

P = Pitch of Chain

Maximum Hub Dia. = PCD - Y

where Y = factor - see tables

Bore diameter for keyed shafts should not exceed 67% Hub Diameter on Steel Sprockets and 57% on Cast Sprockets.

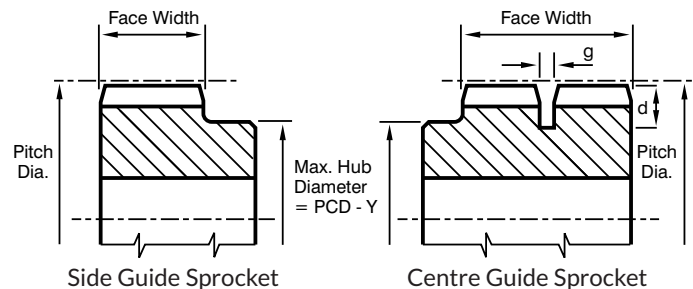

For Centre guide chains the face width should be 5 mm above chain width for chains up to 3/4 inch pitch and 10mm for larger pitch chains.
Side Guide Chain Sprocket Face-Width Tolerance +0.0 -0.5mm.

Sprocket Mounting and Alignment

Sprocket Mounting

To ensure smooth transmission of torque, sprockets should be mounted on shafts with a light interference-fit. A positive mechanical connection is necessary for torque-transmission, with standard side-fitting keys or close fit involute splines being satisfactory. Compression connecting rings and expanding bushes can also be used subject to meeting torque and concentricity requirements; but split tapered bushes must never be used to mount HC sprockets.

For maintenance of alignment it is recommended that sprockets are located positively against a shoulder or step on the shaft. This method of mounting does permit the use of 'A' type platewheels to simplify design and minimise costs.

Sprocket Alignment and Concentricities

Shafts must be parallel in both planes within 0.4mm/Metre of bearing mounting distance. Offset from the machined face on tooth side to the corresponding face of other sprocket should ideally be zero, and otherwise limited to value 'K' mm in table.

Chain Pitch Inches	3/8"	1/2"	3/4"	1"	1 1/2"	2"
K mm	0.55	0.63	0.78	0.91	1.11	1.29

When mounted on shafting sprockets should be concentric to within 0.15mm or 0.1% Pitch Diameter T.I.R.; and have maximum face runout of 0.25mm or 1% Pitch Diameter T.I.R.

Custom Designed Sprockets

Cross+Morse can manufacture Sprockets for all HC chains with diameters up to 1450mm and face widths to 300mm. These can be to customers drawings, or to our design to meet customer drive requirements. Sprockets can also be finished gear cut and hardened from customers blanks. Purchasing both Chain and Sprockets together ensures optimum drive performance, and service life.

Package Drive Design

Our design team can assist in selection, and detailed design of Chain, Sprockets, Shafting, etc, on all Inverted Tooth drives, to ensure correct application of the chains. We also can supply a complete package of Chain, Sprockets, and Shafts, contained in a rigid Chaincase with lubrication, designed to meet Customer's individual drive requirements.

HC Hy-Vo Chain Installation and Lubrication



HC Chain Installation

HC Chains can be furnished rivetted endless, or open ended for connection with a standard connecting pin set. In some case designs, bearing carriers are large enough to install sprockets and endless chain through the openings. Other designs employ housings which are split at the shaft centre to facilitate installation. If chain is installed open ended, the procedures below may be used.

Connecting Chain using Sprocket
Bring ends of chain together on top of larger sprocket in mesh with sprocket teeth, and then insert connecting pin set.

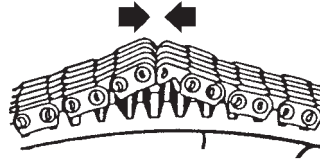

Connecting Chain between Sprocket
On pre-loaded, fixed centre distance drives a hook-up tool similar to that shown may be used to bring ends together.



Fitting Connecting Pin

When connecting the open ends with a pin set, it is important that the longer pin of the set must sit nearest to the outside flank of the guide plate. Spirol pin type connectors are normally used for connecting open ended chains. The spirol pin is driven into each end of the pin with a drift, for rivet type connectors. Washers are used on chains of 3/4" and above pitch of the original design 61-115 series chain.

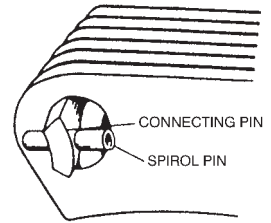

Chain Case Structures

Morse HC Drives are normally on applications where high speed and/or high horsepower transmission is the requirement. The HC Drive should be installed in rigid housings of welded steel or cast construction, complete with shafts, bearings, seals and a proper lubrication system, in order to realise the full performance capability. There should be adequate clearance in chain case for chain to ride over sprockets (min. rad. = Spkt pitch rad + 1/4 chain pitch); and for centrifugal expansion of chain midway between sprockets (allow 12% Centre Distance beyond chain path each side of chain case). Side clearance beyond width of the chain should be equal to or greater than chain pitch.

Lubrication

A proper lubrication system with clean oil of the correct type is necessary for long, quiet, trouble free life of HC Drives. The lubricant must penetrate the chain joints to dissipate frictional heat and flush out foreign particles, and lubricate the surfaces of chain and sprocket contact.

Pressure Lubrication

For chain speeds above 13M/sec, pressure lubrication is required.

The lubrication system should supply filtered oil at 4.5 litres/min. per 25mm width of chain. Spray pipes of 9.5mm I.D. with 2.5mm dia. orifices every 25mm will provide adequate lubrication with oil of SAE 20W or less at pressure of 1.5 Bar. The spray pipe should be located to spray onto the inside of chain as slack strand enters sprocket.

A replacement element full flow oil filter capable of removing particles larger than 25 microns, with a built in relief valve, should be installed between the oil pump and spray pipe. A low oil pressure switch with warning is recommended. Additional components should include an oil sump strainer, oil fill/ breather, magnetic drain plug and an oil level sight gauge.

Lubrication should also be provided to the shaft bearings.

Bath Lubrication

At chain speeds below 13M/sec bath lubrication may be satisfactory. With bath lubrication, the dynamic oil level should be maintained at the lowest point of the chain pitch line, and for this purpose an oil level sight gauge is desirable.

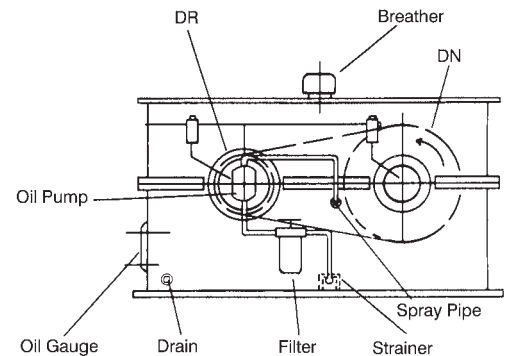

Lubrication Oil Specification

Satisfactory HC chain drive performance depends upon the use of well refined, high quality oil. The best lubricant is Automatic Transmission Fluid (ATF), but light detergent oils as used in Automotive Engines, and Turbine and Spindle Oils are also acceptable. Multiple viscosity oils, gear oils or EP compound oils should not be used. For maximum performance, use oils with SAE Grade related to operating temperature in chart.

Oil Viscosity Recommendations

Surrounding Ambient Temp.	SAE Grade Viscosity	Viscosity Saybolt Secs at 38 °C
Under 4°C	SAE 5*	150 SSU
4°C to 32°C	SAE 10*	200 SSU
Over 32°C	SAE 20	300 SSU

*Use Type A or B Automatic Transmission Fluid (ATF)

Where applications require oil in excess of SAE 20 Grade consult Cross+Morse Engineering

It is desirable to limit oil temperature to 80°C to prevent rapid deterioration. If necessary external cooling fans or oil cooler should be used to achieve this. Generally HC Chains operate with a temperature rise of approx. 25°C above ambient temperature.

Lubrication Changes

Oil should be kept clean to assure long trouble free service. If oil becomes dirty or appears to be contaminated it should be replaced. Good practice is to change oil every 1000 hours or 4 months whichever occurs first, but longer intervals are acceptable if operating conditions allow. When oil is changed, the case should be drained and flushed with suitable solvent. Inspection of lubrication piping, pump and spray pipe orifices should be made, and filter element replaced if dirty. The drive must be kept free of water and foreign material at all times.

American Standard SC Series Inverted Tooth Chains



SC Series Inverted Tooth Chains are manufactured to meet American National Standards ANSI B29.2 and ANSI B29.9 ($\frac{3}{16}$ " pitch). Chains manufactured to these standards are usually identified by the letters SC stamped on the outer link plates. The standards specify the sprockets gearing dimensions to ensure chains of different manufacturers can operate on the same sprockets, but still allowing scope for individual design of the chains. As a result chains from different manufacturers normally will not connect together correctly, and it is essential to replace complete chain assemblies.

All Cross+Morse chains from $\frac{3}{8}$ inch to 1 inch pitch use the pin and rocker assembly from the HC series chains, to ensure the smoothest drives, with minimal friction during articulation on the sprockets, allowing chain speeds up to 25M/S with little wear or heat generation. The $\frac{3}{16}$ inch pitch chains use a simple round pin for maximum strength and durability. Narrow width chains are as standard with outside guide construction, but can be supplied to special order with centre guides. Chains can fully articulate on the pin allowing sprockets down to 11 teeth to be used, also special build duplex chains with teeth on both sides of the chain are suitable for serpentine drives. The $\frac{3}{16}$ inch pitch chains are also available in 304 Stainless Steel.

Different widths and assemblies on all chains are available to special order.

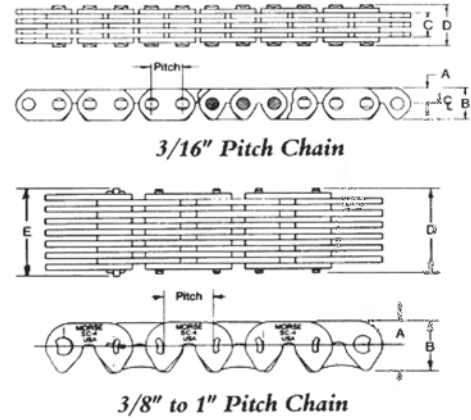

Chain No.	Chain Nominal Width Inches	Chain Pitch Inches (mm)	Height of Chain above Sprocket PD A mm	Height of Chain B mm	Width † between Guides C (min) mm	Width over Rivets D mm	Width over Connecting Pin E mm	Average U.T.S. kN	Weight per kg/Metre
SC 0305s	$\frac{5}{32}$	3/16" (4.76mm)	2.4	5.1	2.39	5.10	6.30	2.22	0.10
SC 0307s	$\frac{7}{32}$				3.97	6.70	7.87	3.34	0.15
SC 0309	$\frac{9}{32}$				5.56	8.27	9.45	4.45	0.18
SC 0311	$\frac{11}{32}$				7.14	9.88	11.02	5.56	0.22
SC 0315	$\frac{15}{32}$				10.32	13.05	14.17	7.78	0.30
SC 0319	$\frac{19}{32}$				—	16.23	17.32	10.00	0.37
SC 0325	$\frac{25}{32}$				—	20.98	22.07	13.35	0.49
SC 0331	$\frac{31}{32}$				—	25.73	26.85	16.70	0.60
R 302	$\frac{1}{2}$				3/8" (9.525mm)	4.9	10.1	—	16.33
SC 302*	$\frac{1}{2}$	11.10	19.53	22.94				8.3	0.57
SC 303	$\frac{3}{4}$	—	22.73	26.14				12.5	0.83
SC 304	1	—	29.13	32.54				16.7	1.12
SC 305	1 $\frac{1}{4}$	—	35.54	38.94				20.9	1.40
SC 306	1 $\frac{1}{2}$	—	41.94	45.34				25.0	1.86
SC 308	2	—	54.74	58.14				33.4	2.23
SC 403	$\frac{3}{4}$	1/2" (12.70mm)	6.5	13.4				—	22.73
SC 404	1				—	29.13	32.54	33	1.49
SC 405	1 $\frac{1}{4}$				—	35.54	38.94	41	1.86
SC 406	1 $\frac{1}{2}$				—	41.94	45.34	50	2.23
SC 408	2				—	54.74	58.14	67	2.98
SC 410	2 $\frac{1}{2}$				—	67.44	70.84	83	3.72
SC 412	3				—	80.14	83.54	100	4.46
SC 606	1 $\frac{1}{2}$				3/4" (19.05mm)	9.8	20.2	—	43.18
SC 608	2	—	55.88	56.08				100	4.46
SC 610	2 $\frac{1}{2}$	—	68.58	68.78				125	5.58
SC 612	3	—	81.28	81.48				150	6.70
SC 616	4	—	106.68	106.88				200	8.93
SC 808	2	1" (25.40mm)	13.0	26.8	—	56.77	57.71	133	5.95
SC 812	3				—	82.17	83.11	200	8.93
SC 816	4				—	107.57	106.51	267	11.91
SC 820	5				—	132.97	133.91	333	14.88
SC 824	6				—	158.37	159.31	400	17.66

* Chain with rivet pin length 16.3mm can also be supplied to special order for replacement of earlier designs

† Applies to chains with outside guide construction only.

\$ SC 0305 and SC 0307 are also stocked in 304 grade Stainless Steel material; ref SC 0305SS and SC 0307SS

Cross+Morse can offer a full range of Sprockets to suit the above chains, manufactured in the best materials and heat treatments to ensure optimum drive performance and long life.

Chain Ordering Information

If Chain part number is not known in order to identify chain please provide the following information:

- | | | | |
|----------------|---|---------------------|--|
| 1. Chain Pitch | Distance between centre of teeth with chain laid flat | 4. Inside Width | Width between outside guides (if applicable) |
| 2. Chain Width | Distance over link plates | 5. Pin Length (max) | If clearances are critical |
| 3. Guiding | Centre or Outside Guide | 6. Chain Length | No of pitches of closed loop chain |