

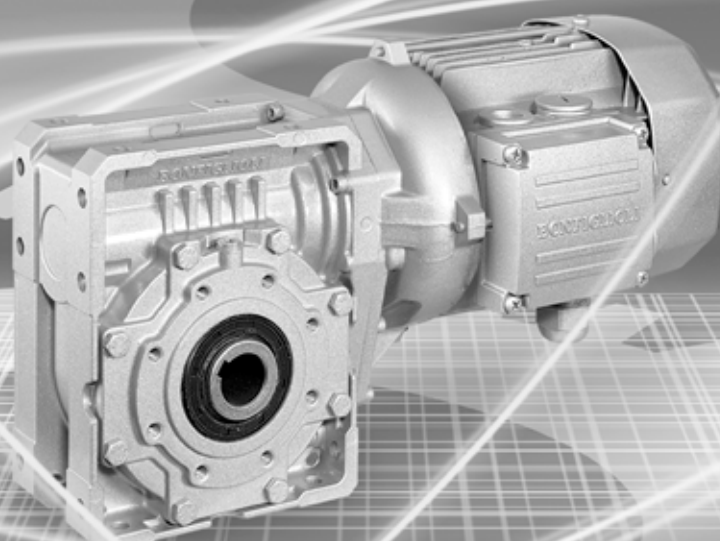

Lista parti di ricambio - Spare parts list - Ersatzteilliste
Liste des pieces detachees - Lista de piezas de recambio

W



LISTA PARTI DI RICAMBIO	SPARE PARTS LIST	ERSATZTEILISTE	LISTE DES PIECES DETACHEES	LISTA DE PIEZAS DE RECAMBIO	
Descrizione	Description	Beschreibung	Description	Descripción	
1 Layout generale e simbologia	<i>General layout and symbols</i>	Allgemeines Layout und Symbole	<i>Schéma d'implantation et symboles</i>	Presentación general y simbología	2
W 63 - W 75 - W 86 - WR 63 - WR 75 - WR 86					
2 Modulo base	<i>Base module</i>	Basismodul	<i>Module base</i>	Módulo base	3
W 63 - W 75 - W 86					
2.1.1 - Modulo entrata S	<i>2.1.1 - S input module</i>	2.1.1 - Antriebseinheit S	<i>2.1.1 - Module entrée S</i>	2.1.1 - Módulo de entrada S	4
2.1.2 - Modulo entrata HS	<i>2.1.2 - HS input module</i>	2.1.2 - Antriebseinheit HS	<i>2.1.2 - Module entrée HS</i>	2.1.2 - Módulo de entrada HS	5
2.1.3 - Modulo entrata P(IEC) B5	<i>2.1.3 - Input module P(IEC) B5</i>	2.1.3 - Antriebseinheit P(IEC)	<i>2.1.3 - Module entrée P(IEC) B5</i>	2.1.3 - Módulo de entrada P(IEC) B5	6
2.1.4 - Modulo entrata P(IEC) B14	<i>2.1.4 - Input module P(IEC) B14</i>	2.1.4 - Antriebseinheit P(IEC) B14	<i>2.1.4 - Module entrée P(IEC) B14</i>	2.1.4 - Módulo de entrada P(IEC) B14	7
WR 63 - WR 75 - WR 86					
2.2.1 - Modulo WR_HS	<i>2.2.1 - Module WR_HS</i>	2.2.1 - Antriebseinheit WR_HS	<i>2.2.1 - Module WR_HS</i>	2.2.1 - Módulo WR_HS	8
2.2.2 - Modulo WR_P(IEC) B5	<i>2.2.2 - Module WR_P(IEC) B5</i>	2.2.2 - Antriebseinheit WR_P(IEC) B5	<i>2.2.2 - Module WR_P(IEC) B5</i>	2.2.2 - Módulo WR_P(IEC) B5	9
W 110 - WR 110					
3 Modulo base	<i>Base module</i>	Basismodul	<i>Module base</i>	Módulo base	10
W 110					
3.1.1 - Modulo entrata S	<i>3.1.1 - S input module</i>	3.1.1 - Antriebseinheit S	<i>3.1.1 - Module entrée S</i>	3.1.1 - Módulo de entrada S	11
3.1.2 - Modulo entrata HS	<i>3.1.2 - HS input module</i>	3.1.2 - Antriebseinheit HS	<i>3.1.2 - Module entrée HS</i>	3.1.2 - Módulo de entrada HS	12
3.1.3 - Modulo entrata P(IEC) B5	<i>3.1.3 - Input module P(IEC) B5</i>	3.1.3 - Antriebseinheit P(IEC)	<i>3.1.3 - Module entrée P(IEC) B5</i>	3.1.3 - Módulo de entrada P(IEC) B5	13
3.1.4 - Modulo entrata P(IEC) B14	<i>3.1.4 - Input module P(IEC) B14</i>	3.1.4 - Antriebseinheit P(IEC) B14	<i>3.1.4 - Module entrée P(IEC) B14</i>	3.1.4 - Módulo de entrada P(IEC) B14	14
WR 110					
3.2.1 - Modulo WR_HS	<i>3.2.1 - Module WR_HS</i>	3.2.1 - Antriebseinheit WR_HS	<i>3.2.1 - Module WR_HS</i>	3.2.1 - Módulo WR_HS	15
3.2.2 - Modulo WR_P(IEC) B5	<i>3.2.2 - Module WR_P(IEC) B5</i>	3.2.2 - Antriebseinheit WR_P(IEC) B5	<i>3.2.2 - Module WR_P(IEC) B5</i>	3.2.2 - Módulo WR_P(IEC) B5	16
4 Accessori	<i>Accessories</i>	Zubehör	<i>Accessoires</i>	Accesorios	17
5 Motori elettrici	<i>Electric motor</i>	Elektromotoren	<i>Moteur électriques</i>	Motores eléctricos	20
Revisioni L'indice di revisione del catalogo è riportato a pag. 26. Al sito www.bonfiglioli.com sono disponibili i cataloghi con le revisioni aggiornate.	<i>Revisions</i> <i>Refer to page 26 for the catalogue revision index.</i> <i>Visit www.bonfiglioli.com to search for catalogues with up-to-date revisions.</i>	Änderungen Das Revisionsverzeichnis des Katalogs wird auf Seite 26 wiedergegeben. Auf unserer Website www.bonfiglioli.com werden die Kataloge in ihrer letzten, überarbeiteten Version angeboten.	<i>Révisions</i> <i>Le sommaire de révision du catalogue est indiqué à la page 26.</i> <i>Sur le site www.bonfiglioli.com des catalogues avec les dernières révisions sont disponibles.</i>	Revisiones El índice de revisión del catálogo se indica en la pág. 26. En el sitio de Internet www.bonfiglioli.com están disponibles los catálogos con las revisiones actualizadas.	

1 - LAYOUT GENERALE E
SIMBOLOGIA





1 - GENERAL LAYOUT AND
SIMBOLS

1 - ALLGEMEINES LAYOUT UND
SYMBOLE

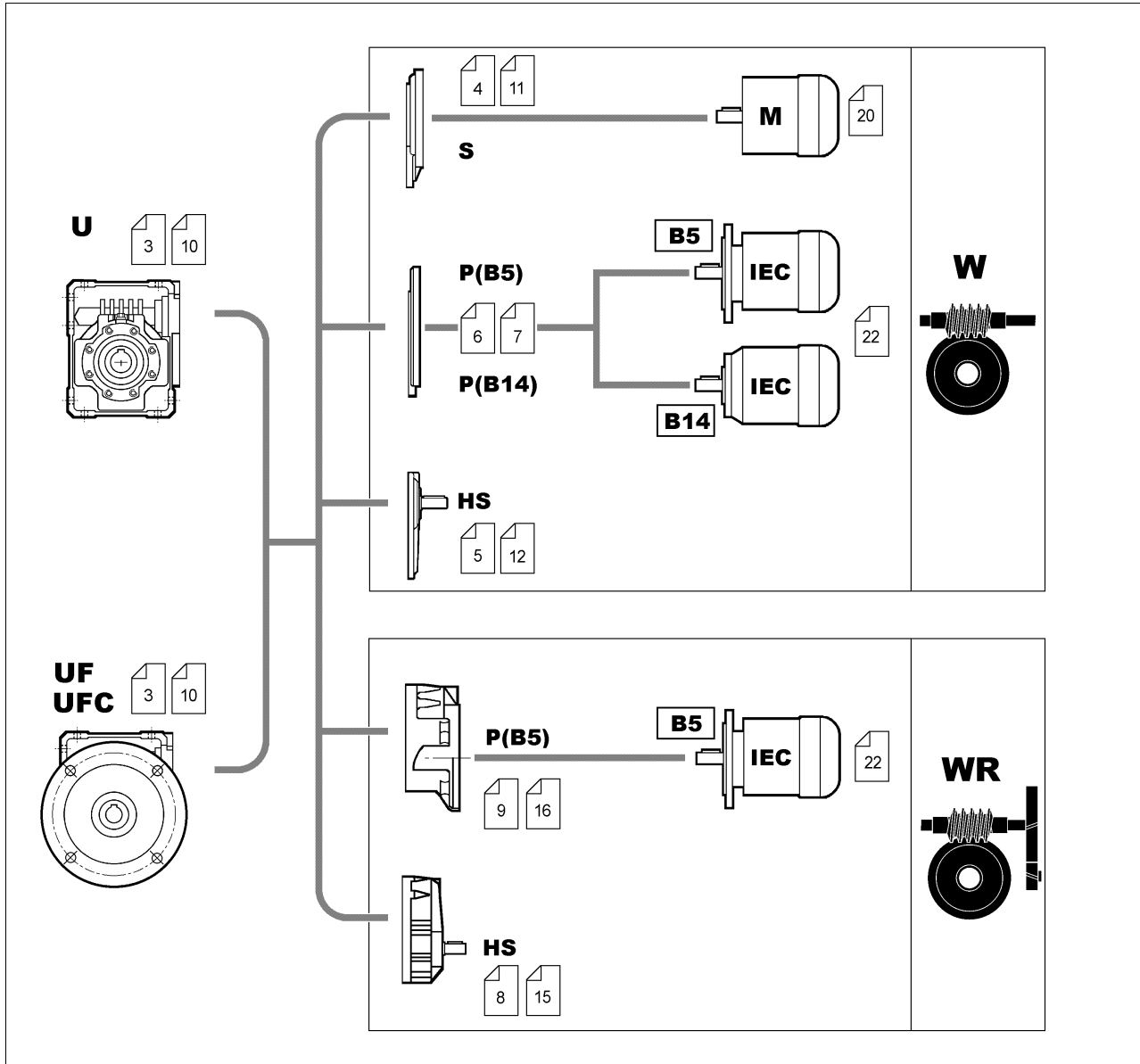
1 - SCHÉMA D'IMPLANTATION ET
SYMBOLES

1 - PRESENTACIÓN GENERAL Y
SIMBOLOGÍA



		Marche consigliate <i>Recommended make</i> vorgeschlagenen Marken <i>Producteurs conseillé</i> Aconsejado marchas
	Cuscinetto <i>Bearing</i> Lager <i>Roulement</i> Cojinete	SKF - FAG
	Anello di tenuta <i>Oil seal</i> Simmerring <i>Bague d'étanchéité</i> Anillo de estanqueidad	CORCOS - STEFA
	O-Ring <i>O-Ring seal</i> O-Ring <i>Bague O-Ring</i> Anillo O-Ring	—
	V-Ring <i>V-Ring seal</i> V-Ring <i>Bague V-Ring</i> Anillo V-Ring	—
	Tappo olio <i>Oil plug</i> Ölverschluß <i>Bouchon d'huile</i> Tapón de aceite	—



W 63 ... W 86

WR 63 ... WR 86

2 - MODULO BASE

2 - BASE MODULE

2 - BASISMODUL

2 - MODULE BASE

2 - MÓDULO BASE

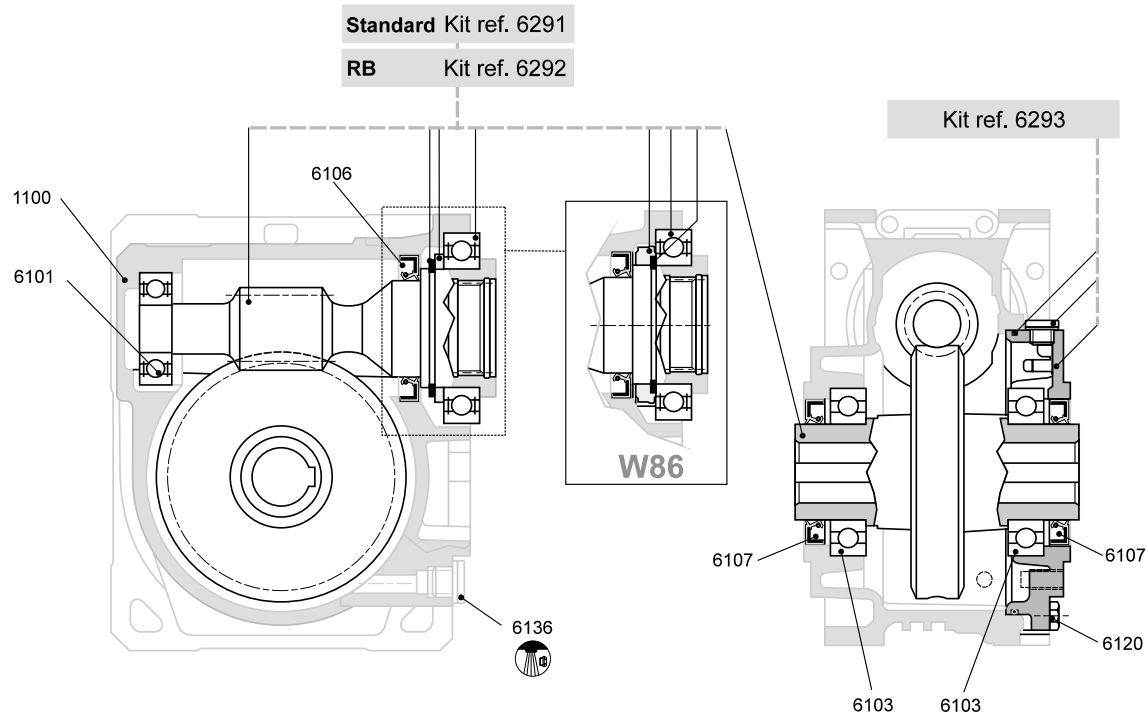

		W 63	W 75	W 86
	6101	6204 2RS	6205 2RS	6305 2RS
	6102	6204	6205	6206
	6103	6008	6010	6210
	6106	40/62/7 L (i=7-30) 35/62/7 L (i=45-100)	45/72/8 L	50/80/8 L (i=7-30) 45/80/10 L (i=45-100)
	6107	40/62/7 DL	50/72/8 DL	50/80/10 DL
	6108	20/35/7 DL	25/40/7 DL	30/47/7 DL
	6112	OR 2450	OR 3550	OR 4625
	6137	1/4" Gas	1/4" Gas	1/4" Gas

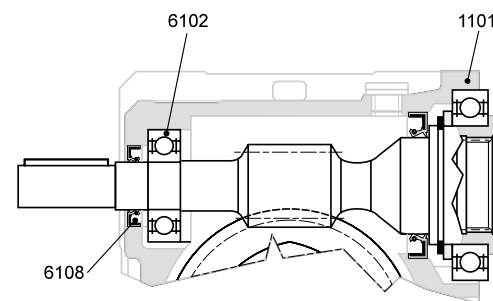

Opzione RB / RB Option



W 63

W 75

W 86

2.1.1 - Modulo entrata S

2.1.1 - S input module

2.1.1 - Antriebseinheit S

2.1.1 - Module entrée S

2.1.1 - Módulo de entrada S

	W 63	W 75	W 86
6360	OR 4131	OR 4150	OR 4150

	W 63	W 75	W 86
6364	V-40S	—	—

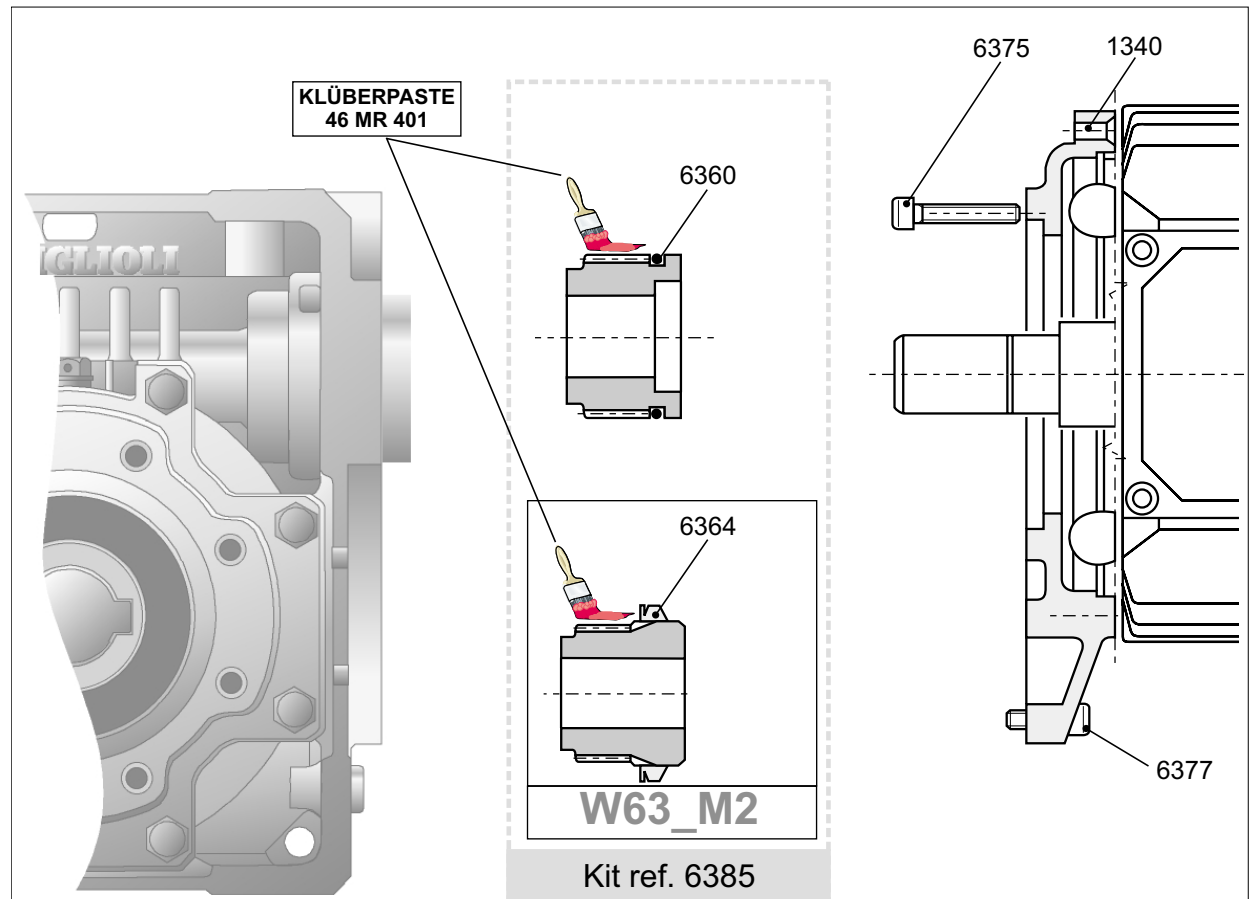



W 63

W 75

W 86

2.1.2 - Modulo entrata HS

2.1.2 - HS input module

2.1.2 - Antriebseinheit HS

2.1.2 - Module entrée HS

2.1.2 - Módulo de entrada HS

Standard Kit ref. 6291

RB Kit ref. 6292

Kit ref. 6355*

Kit ref. 6356

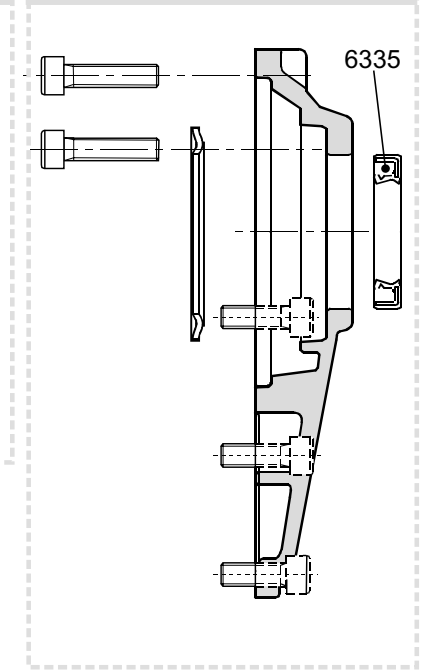
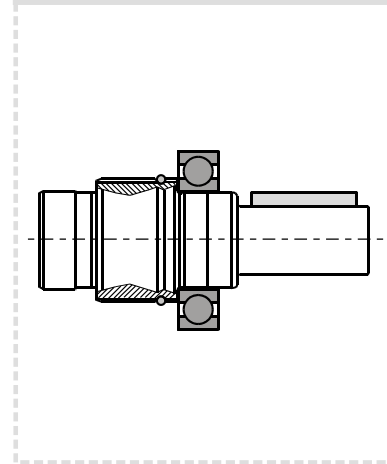
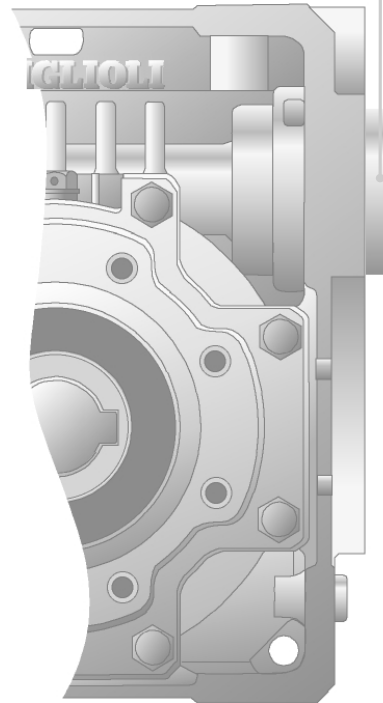

	W	W 75	W 86
6335	25x32x463 B10F	35x47x4.5 L	35x47x4.5 L



W 63

W 75

W 86

2.1.3 - Modulo entrata P(IEC) B5

2.1.3 - Input module P(IEC) B5

2.1.3 - Antriebseinheit P(IEC) B5

2.1.3 - Module entrée P(IEC) B5

2.1.3 - Módulo de entrada P(IEC) B5

 O-RING	W 63	W 75	W 86
6300	OR 4131	OR 4150	OR 4150

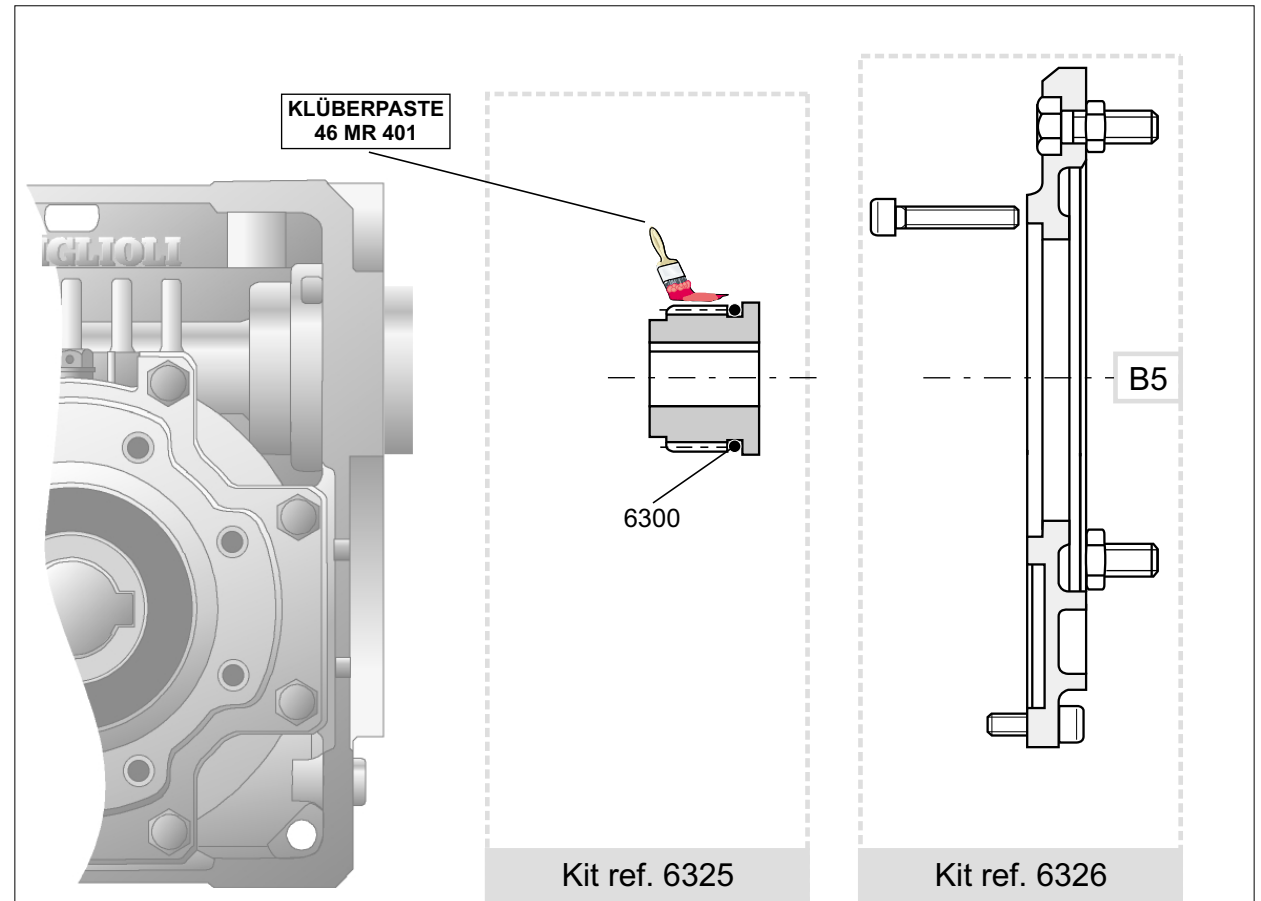



W 63

W 75

W 86

2.1.4 - Modulo entrata P(IEC) B14

2.1.4 - Input module P(IEC) B14

2.1.4 - Antriebseinheit P(IEC) B14

2.1.4 - Module entrée P(IEC) B14

2.1.4 - Módulo de entrada P(IEC) B14

 O-RING	W 63	W 75	W 86
6300	OR 4131	OR 4150	OR 4150

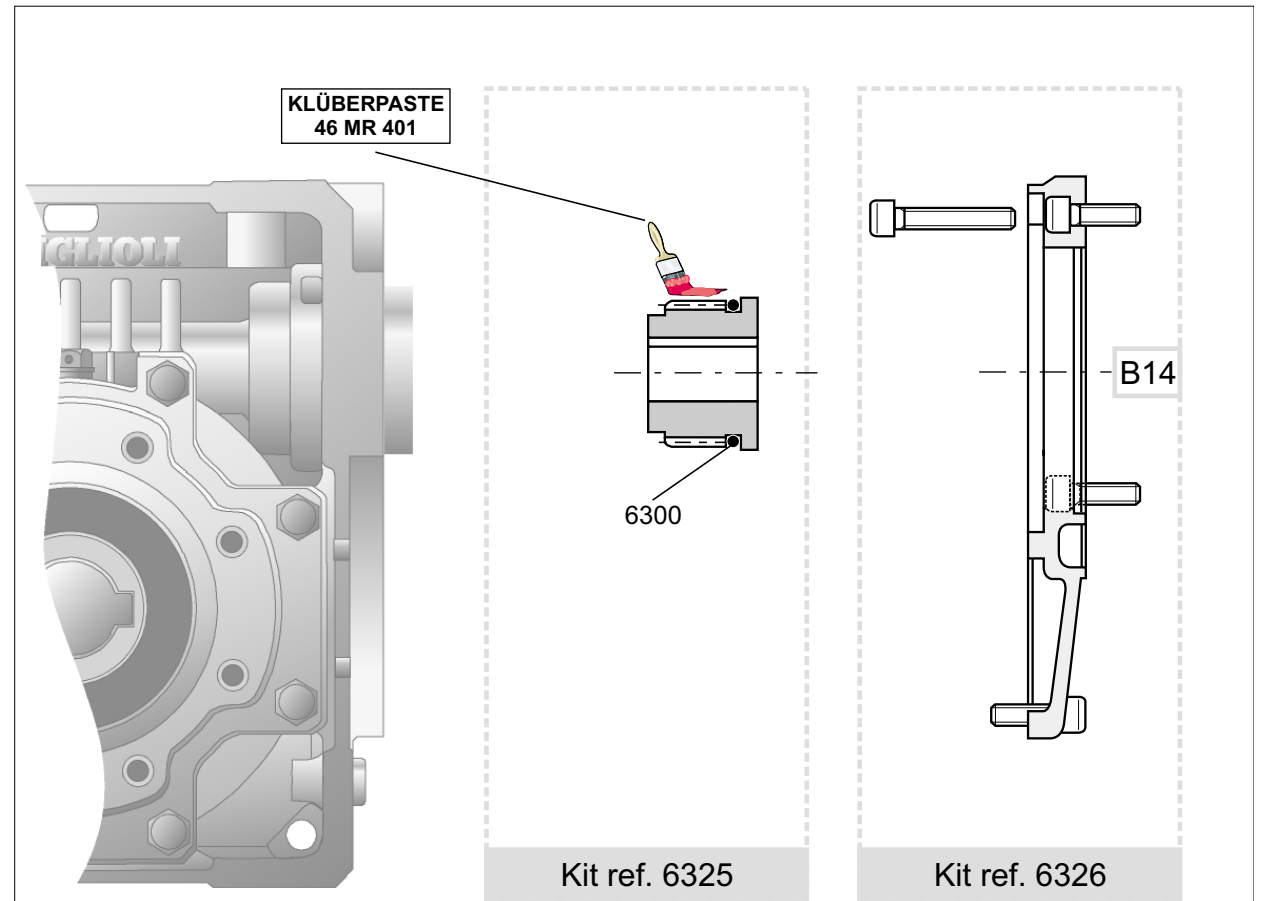



WR 63

WR 75

WR 86

2.2.1 - Modulo WR_HS

2.2.1 - Module WR_HS

2.2.1 - Antriebseinheit WR_HS

2.2.1 - Module WR_HS

2.2.1 - Módulo WR_HS

	WR 63	WR 75 - WR 86
6230	6203	6205
6231	6001	6203

	WR 63	WR 75 - WR 86
6242	17/40/7 DL	25/52/7 DL

	WR 63	WR 75 - WR 86
6256	1/4" Gas	1/4" Gas
6257	1/4" Gas	1/4" Gas

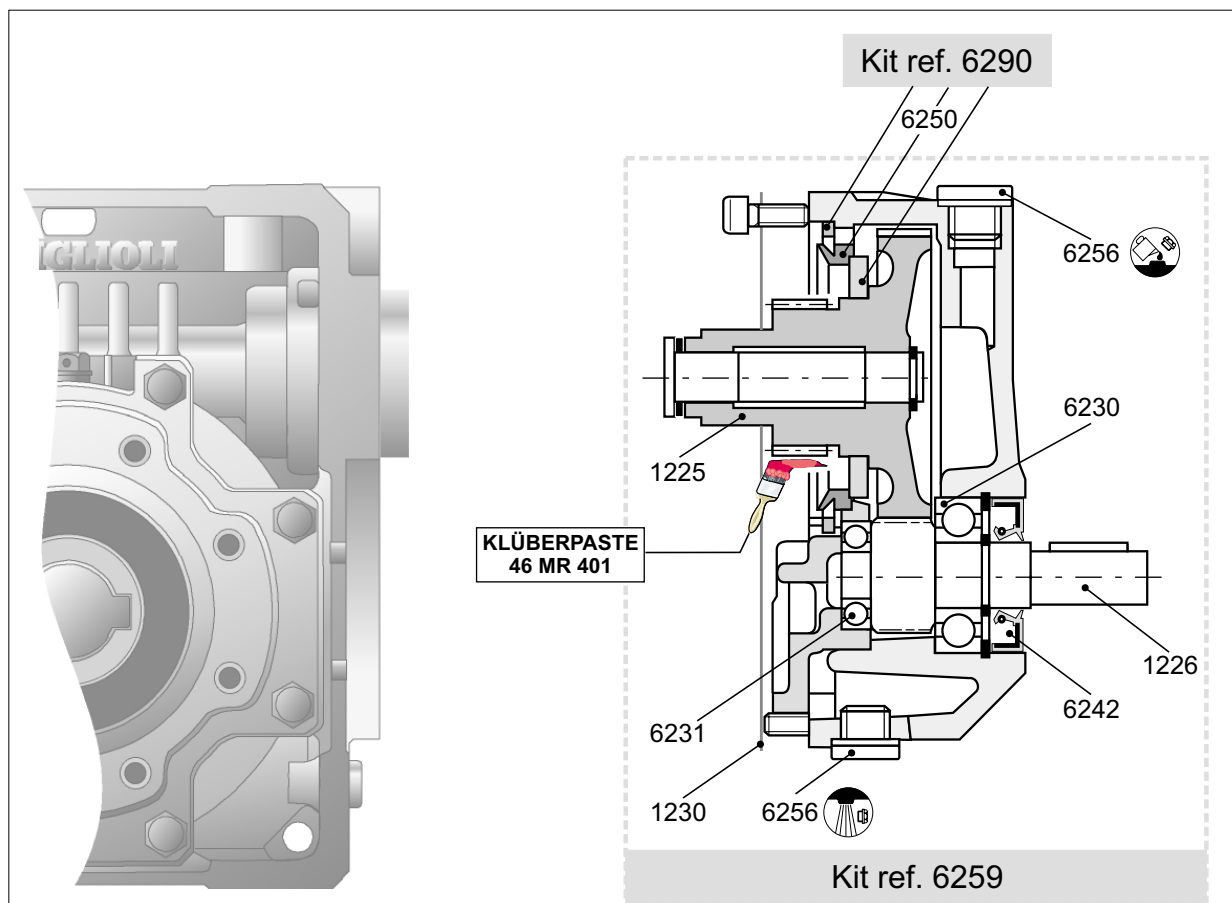



WR 63

WR 75

WR 86

2.2.2 - Modulo WR_P(IEC) B5

2.2.2 - Module WR_P(IEC) B5

2.2.2 - Antriebseinheit
WR_P(IEC) B5

2.2.2 - Module WR_P(IEC) B5

2.2.1 - Módulo WR_P(IEC) B5

	WR 63	WR 75 - WR 86
6200	16005	16005 (P63-P71) 6206 (P80) 61908 (P90)
6201	609	609 (P63-P71) 6000 (P80-P90)

	WR 63	WR 75 - WR 86
6212	25/47/7 L	25/47/7 L (P63-P71) 30/62/7 L (P80) 40/62/7 L (P90)

	WR 63	WR 75 - WR 86
6226	1/4" Gas	1/4" Gas
6227	1/4" Gas	1/4" Gas

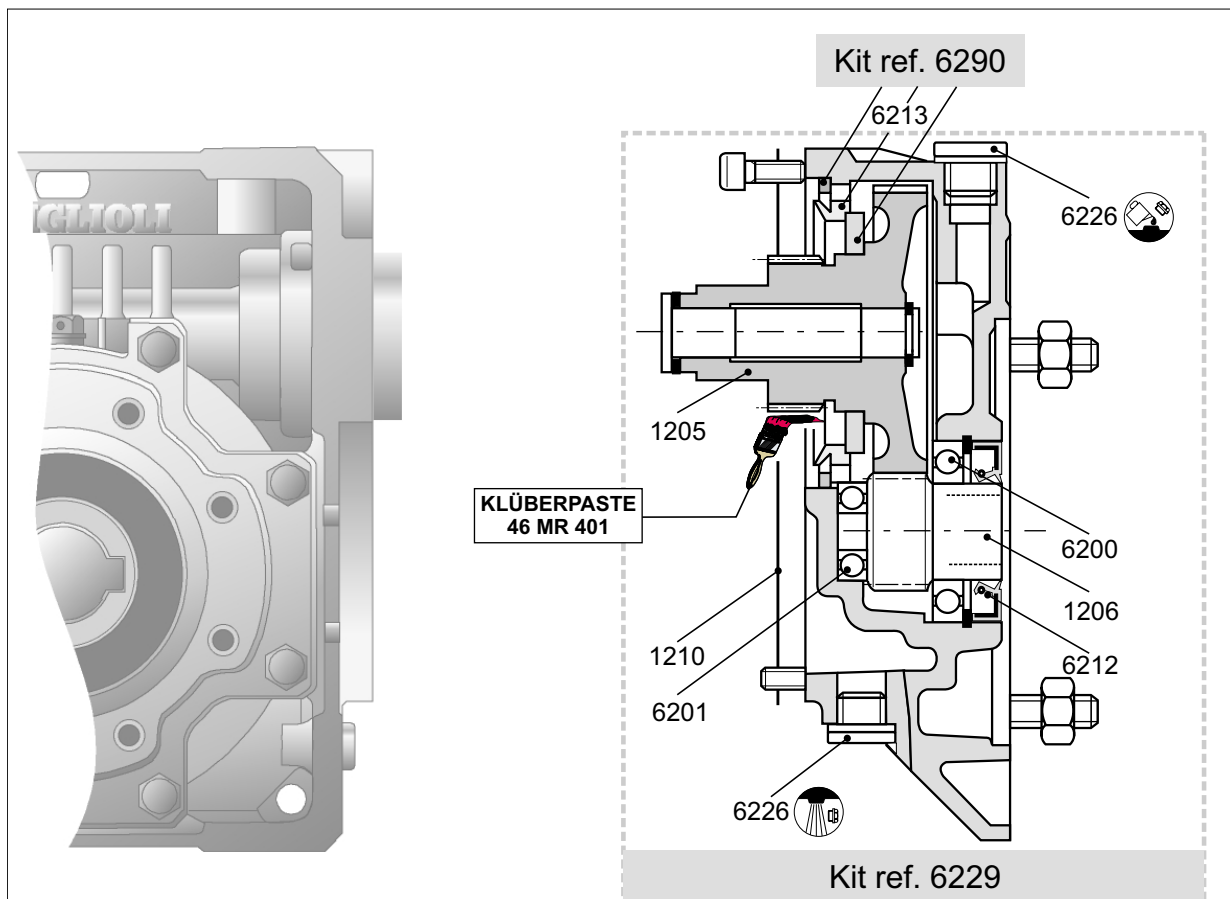



W 110

WR 110

3 - MODULO BASE

3 - BASE MODULE

3 - BASISMODUL

3 - MODULE BASE

3 - MÓDULO BASE



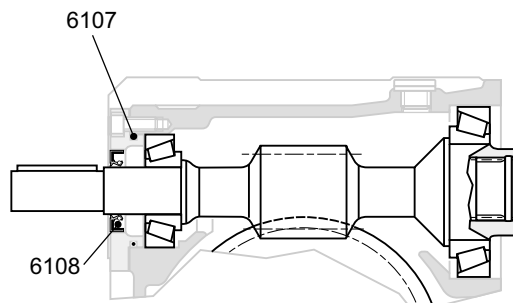
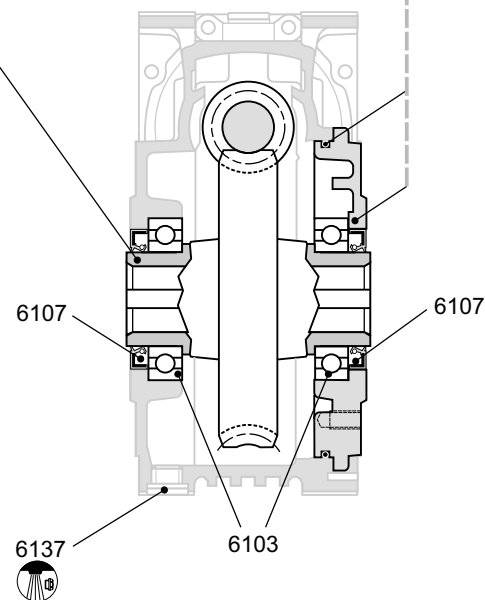
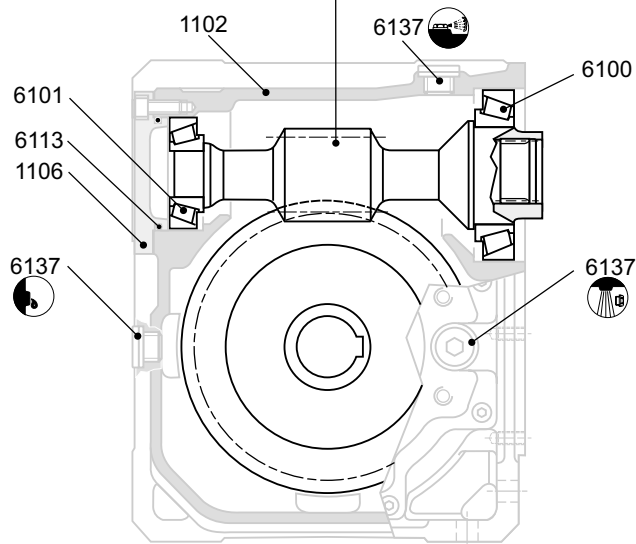

Standard Kit ref. 6294

RB Kit ref. 6292

Kit ref. 6356



Opzione RB / RB Option

		W 110
	6100	30212
	6101	31306
	6103	6212
	6107	60/90/8 DL
	6108	30/52/10 DL
	6113	OR 3262
	6137	1/2" Gas



W 110

3.1.1 - Modulo entrata S

3.1.1 - S input module

3.1.1 - Antriebseinheit S

3.1.1 - Module entrée S

3.1.1 - Módulo de entrada S

	W 110
6365	55/80/8 L
	W 110
6360	OR 4150
6361	OR 2425

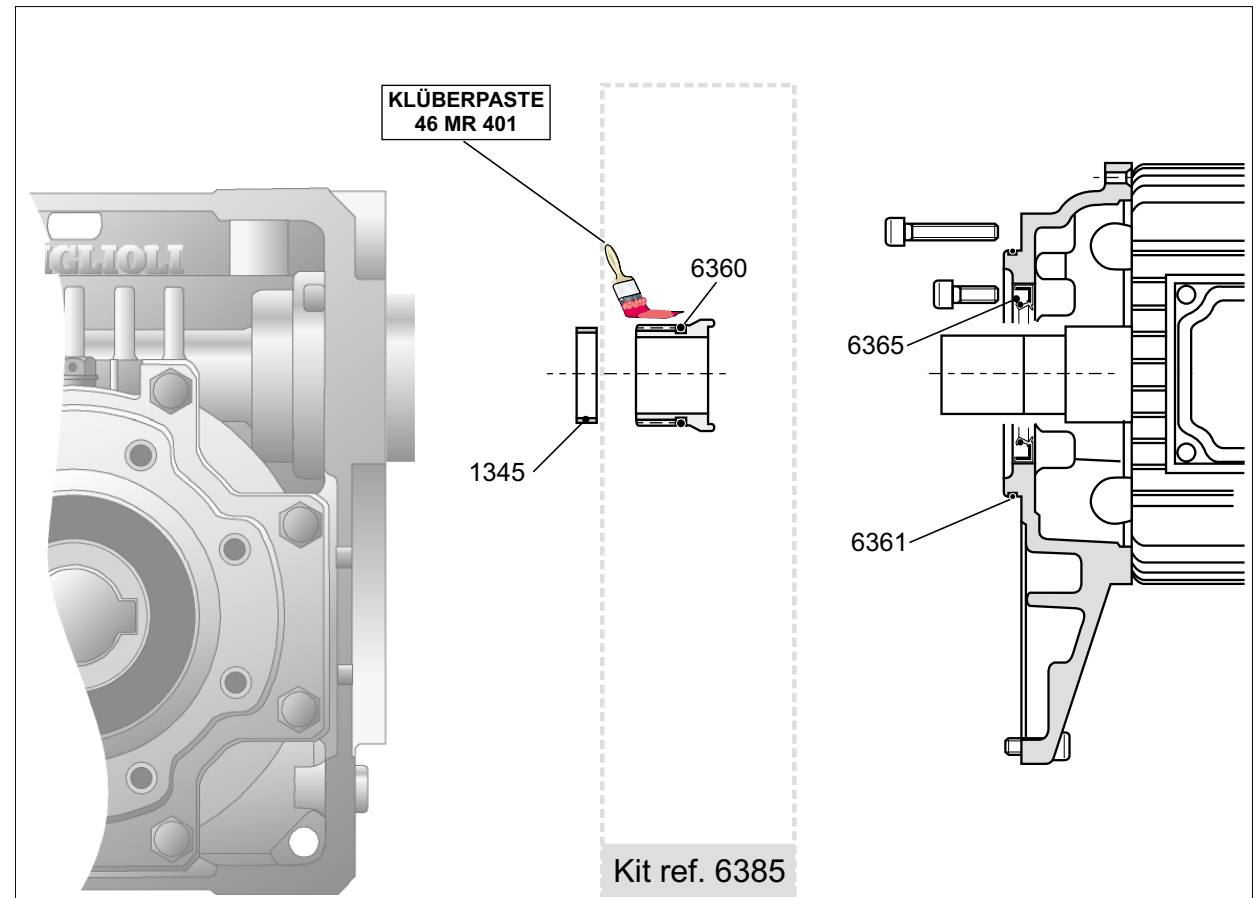



W 110

3.1.2 - Modulo entrata HS

3.1.2 - HS input module

3.1.2 - Antriebseinheit HS

3.1.2 - Module entrée HS

3.1.2 - Módulo de entrada HS

Standard Kit ref. 6294

RB Kit ref. 6292

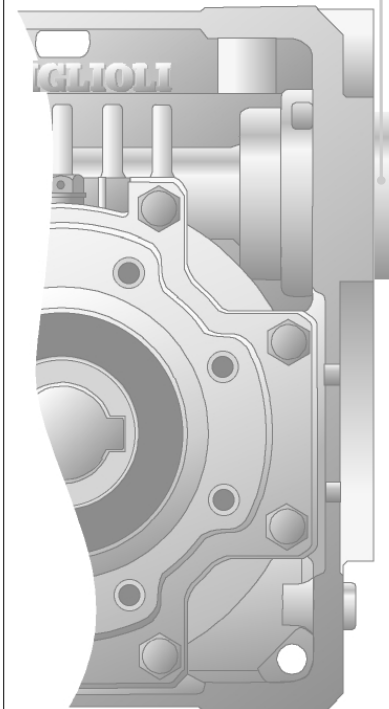

Kit ref. 6355*

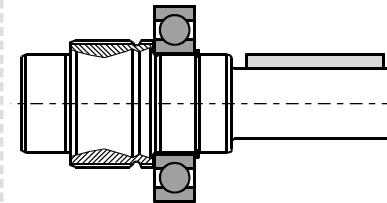

Kit ref. 6356

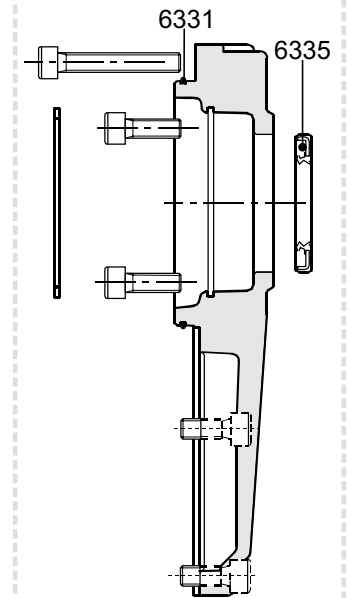

	W 110
6335	35 x 62 x 7 DL

	W 110
6331	OR 2400



W 110

3.1.3 - Modulo entrata
P(IEC) B5

3.1.3 - Input module
P(IEC) B5

3.1.3 - Antriebseinheit
P(IEC) B5

3.1.3 - Module entrée
P(IEC) B5

3.1.3 - Módulo de entrada
P(IEC) B5

	W 110
6305	55/80/8 L
	W 110
6300	OR 4150
6301	OR 2425

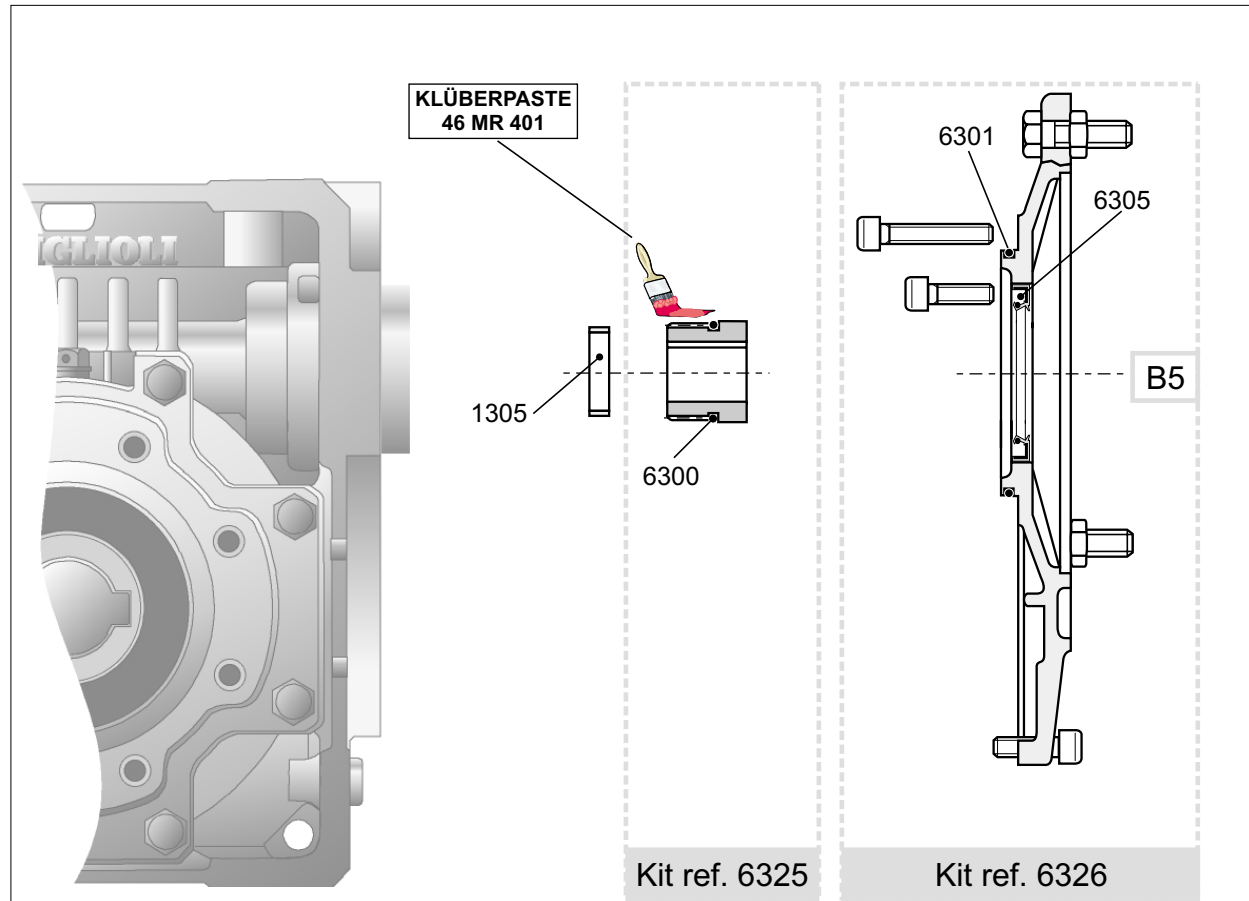



W 110

3.1.4 - Modulo entrata P(IEC) B14

3.1.4 - Input module P(IEC) B14

3.1.4 - Antriebseinheit P(IEC) B14

3.1.4 - Module entrée P(IEC) B14

3.1.4 - Módulo de entrada P(IEC) B14

	W 110
6305	55/80/8 L
	W 110
6300	OR 4150
6301	OR 2425

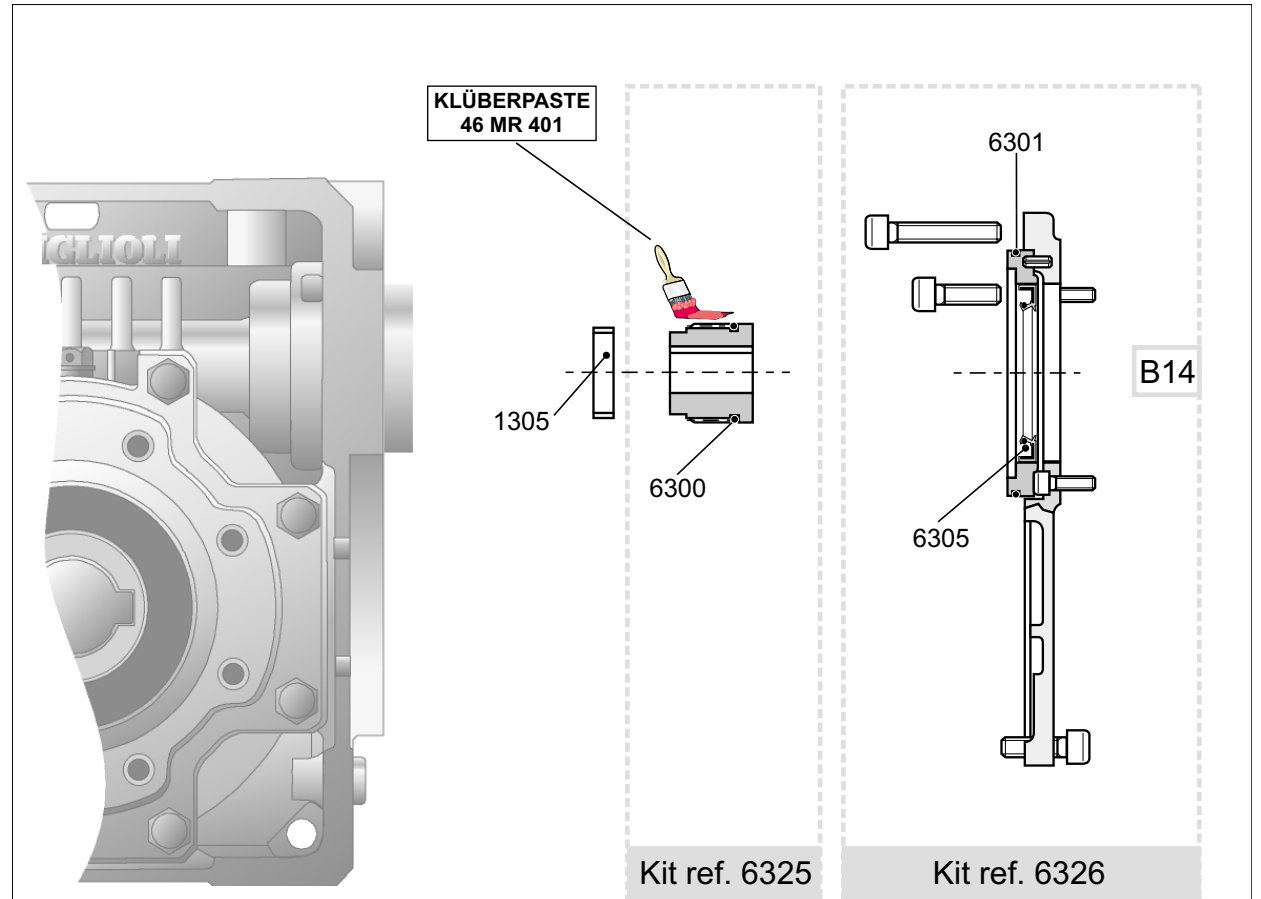



WR 110

3.2.1 - Modulo WR_HS

3.2.1 - Module WR_HS

3.2.1 - Antriebseinheit WR_HS

3.2.1 - Module entrée WR_HS

3.2.1 - Módulo de entrada WR_HS

	WR 110
6230	6008
6231	6205

	WR 110
6242	40/62/7 DL
6243	55/80/8 L

	WR 110
6256	1/4" Gas
6257	1/4" Gas

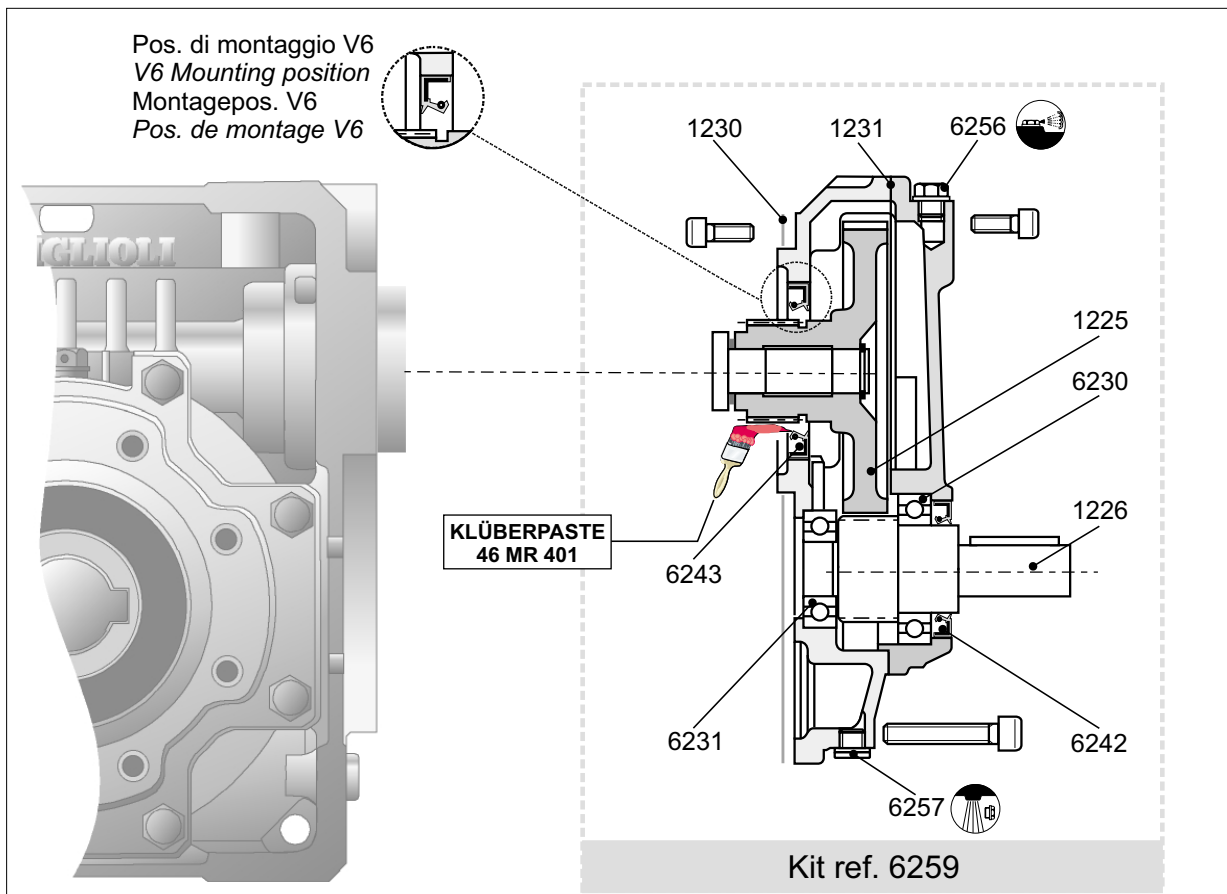



WR 110

3.2.2 - Modulo WR_P(IEC) B5

3.2.2 - Module WR_P(IEC) B5

3.2.2 - Antriebseinheit
WR_P(IEC) B5

3.2.2 - Module entrée
WR_P(IEC) B5

3.2.2 - Módulo de entrada
WR_P(IEC) B5

	WR 110
6200	16005 (P71) 6008 (P80_P112)
6201	609 (P71) 6205 (P80_P112)

	WR 110
6210	55/80/8 L
6212	25/47/7 L (P71) 40/62/7 L (P80_P112)

	WR 110
6226	1/4" Gas
6227	1/4" Gas

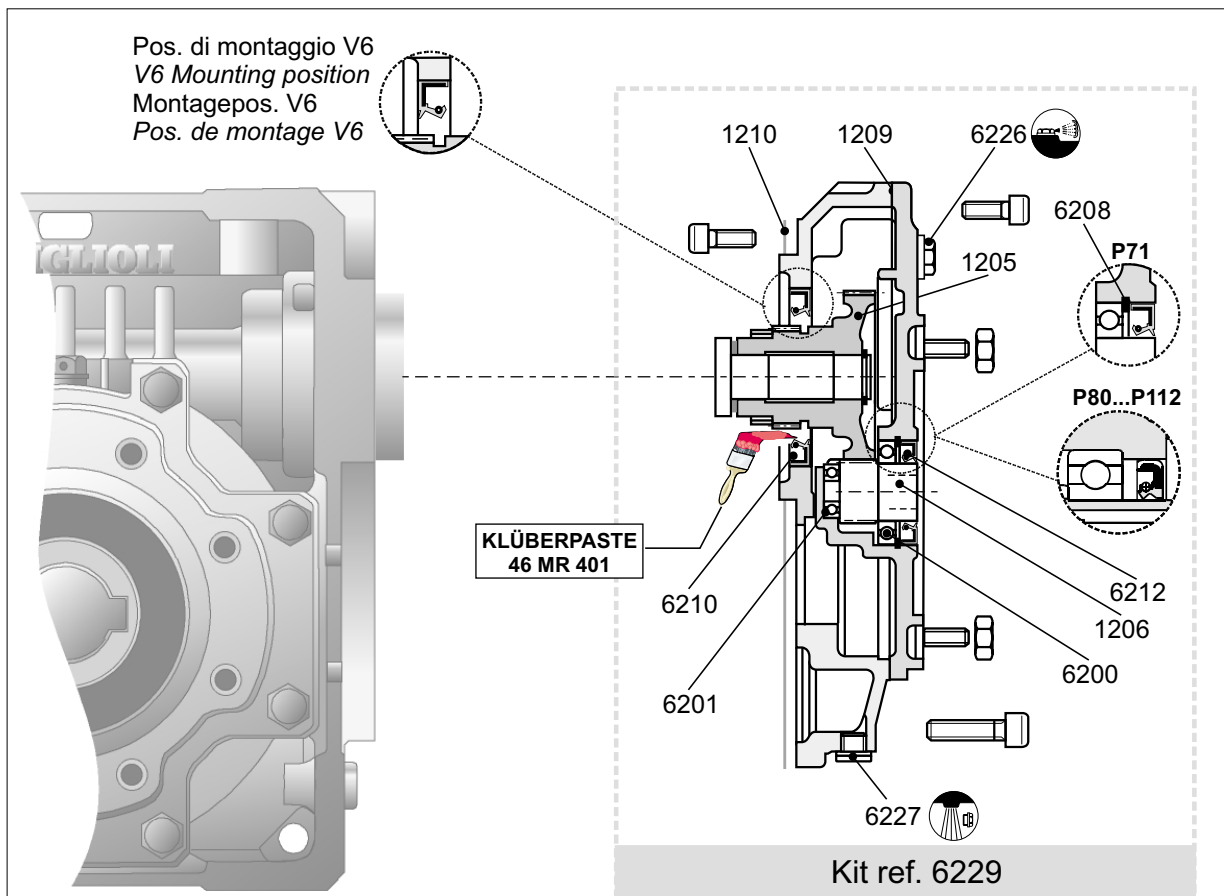



W 63 ... W 86

WR 63 ... WR 86

4 - ACCESSORI

4 - ACCESSORIES

4 - ZUBEHÖR

4 - ACCESSOIRES

4 - ACCESORIOS

(S39)

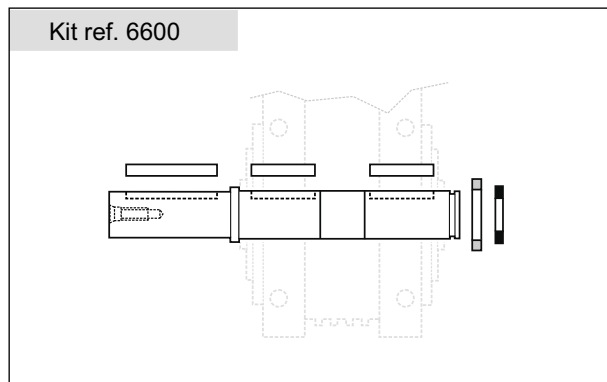

Kit albero lento semplice / *Plug-in single shaft*
Kit - einfache Abtriebswelle / *Kit arbre de sortie simple*
Kit del eje lento sencillo

(S40)

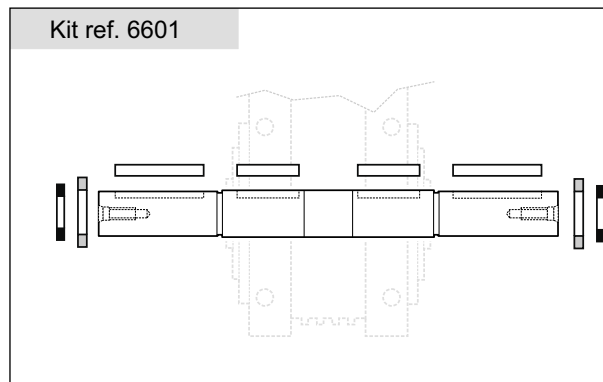

Kit albero lento doppio / *Plug-in double shaft*
Kit - doppelte Abtriebswelle / *Kit arbre de sortie double*
Kit del eje lento doble

(S41)

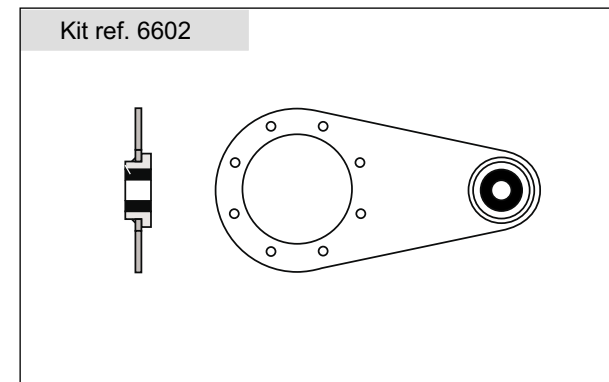

Kit braccio di reazione / *Torque arm*
Kit - Momentenabstützung / *Kit bras de réaction*
Kit del brazo de reacción

(S42)

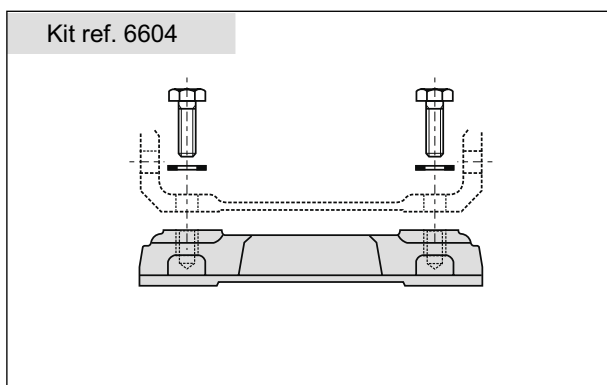

Kit piedi KA / *VF/A interchangeability Kit*
Kit - Füße KA / *Kit pattes LA / VF/A*
Kit de los pies KA

Kit piedi KV / *VF/V interchangeability Kit*
Kit - Füße KV / *Kit pattes KV/ VF/V*
Kit de los pies KA

(S43)

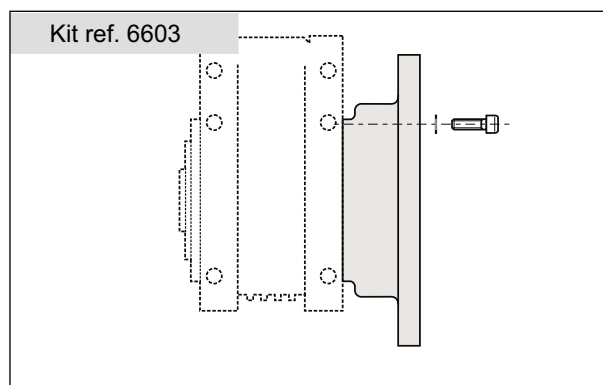

Kit flangia / *Bolt-on flange*
Kit - Flansch / *Kit bride*
Kit de la brida

(S44)

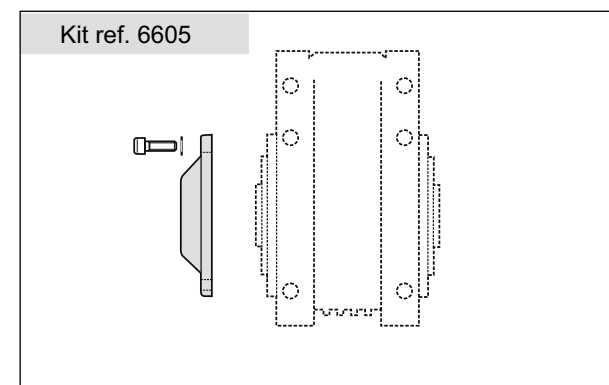

Kit cappello di protezione / *Safety cover Kit*
Kit - Schutzkappe / *Kit capuchon protecteur*
Kit del capuchón de protección

**W 63**

Limitatore di coppia

Torque limiter

Rutschkupplung

Limiteur de couple

Limitadores de par

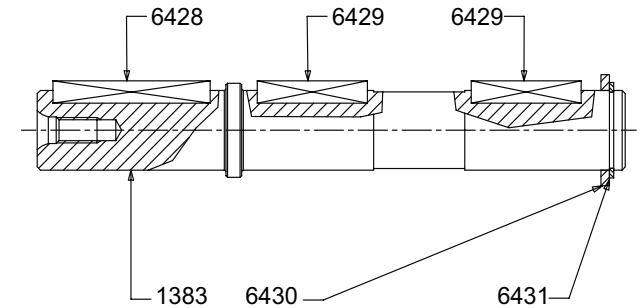
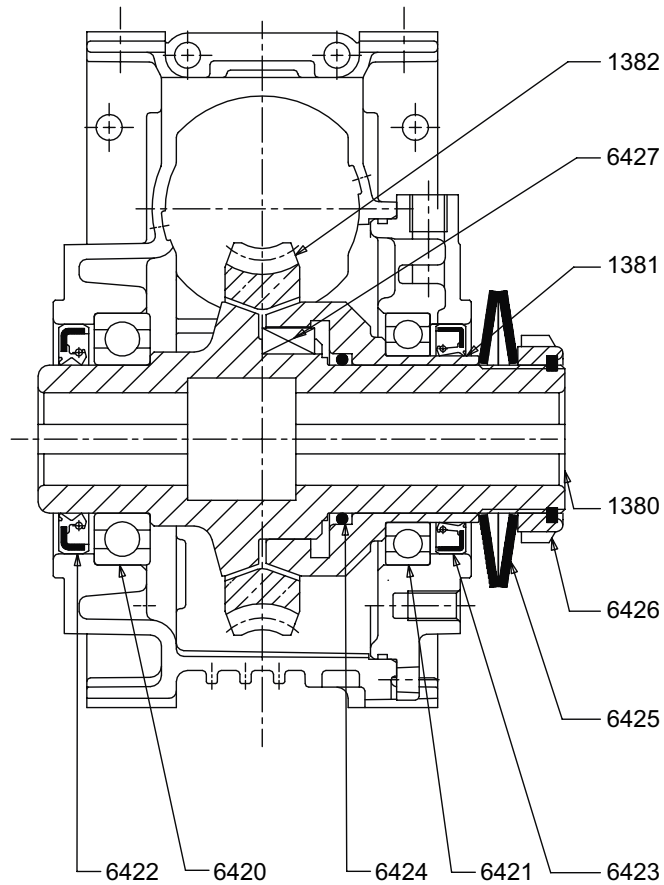

W 63 L...		
	6420	6008 "FLT"
	6421	61909
	6422	40x62x7 "DL"
	6422	40x62x7 "DL"
	VITON®	
	6423	45x62x8 "DL"
	6423	45x62x8 "DL"
VITON®		
	6424	OR144
	6425	C70x41x2
	6426	M40x1.5
	6427	8x7x14 "C"
	6428	8x7x50 "A"
	6429	8x7x35 "A"
	6430	25x35x2 R
	6431	De 25

	Denominazione	Description	Benennung	Dénomination	Denominación
1380	Mozzo per limitatore	Torque limiter hub	Vollwelle für Rutschkupplung	Moyeu pour limiteur	Buje para limitador
1381	Boccola per limitatore	Sleeve	Buchse für Rutschkupplung	Douille pour limiteur	Casquillo para limitador
1382	Corona	Worm wheel	Schneckenrad	Roue	Corona
1383	Albero lento sporgente	Plug-in output shaft	Ausgangswelle	Arbre lent solid	Eje lento saliente

**W 75****W 86****W 110****Limitatore di coppia****Torque limiter****Rutschkupplung****Limiteur de couple****Limitador de par**

		W 63 L...	W 75 L...	W 86 L...	W 110 L...
	6420	6008 "FLT"	6010 "FLT"	6210 "FLT"	6212
	6421	61909	61911	61913	6014
	6422	40x62x7 "DL"	50x72x8 "DL"	50x80x10 "DL"	60x90x8 "DL"
	6422	40x62x7 "DL"	50x72x8 "DL"	50x80x8 "DL"	60x90x8 "DL"
	6423	45x62x8 "DL"	55x72x7 "DL"	65x80x7 "DL"	70x90x10 "DL"
	6422	45x62x8 "DL"	55x72x7 "DL"	65x80x7 "DL"	70x90x8 "DL"
	6424	OR144	OR2162	OR2212	OR2224
	6425	C70x41x2	C90x46x2.5	C112x57x3	C125-61-5
	6426	M40x1.5	M45x1.5	M55x1.5	M60x1.5
	6427	8x7x14 "C"	0x8x20 "C"	14x9x20 "C"	22X9X22 "C"
	6428	8x7x50 "A"	8x7x50 "A"	10x8x50 "A"	12x8x60 "A"
	6429	8x7x35 "A"	8x7x40 "A"	10x8x40 "A"	12x8x45 "A"
	6430	25x35x2 R	30x42X2 R	35x45x2.5 R	42x52x5.5 R
	6431	De 25	De30	De 35	De 42

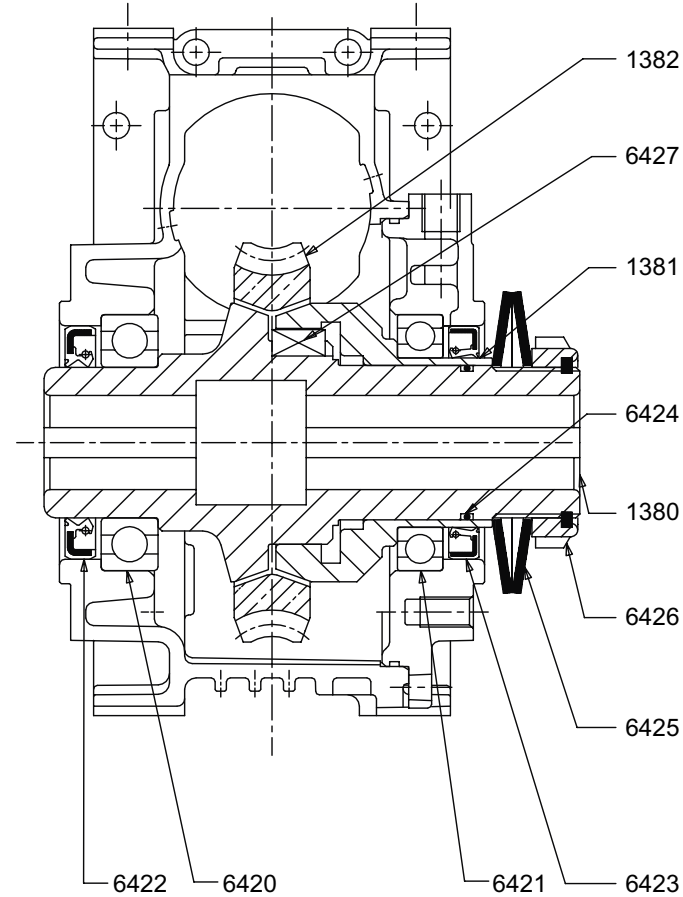
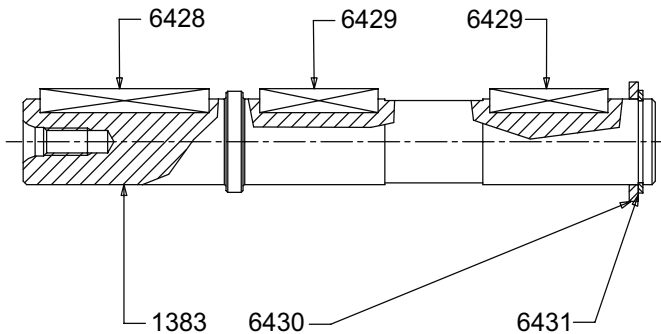

	Denominazione	Description	Benennung	Dénomination	Denominación
1380	Mozzo per limitatore	<i>Torque limiter hub</i>	Vollwelle für Rutschkupplung	<i>Moyeu pour limiteur</i>	Buje para limitador
1381	Boccola per limitatore	<i>Sleeve</i>	Buchse für Rutschkupplung	<i>Douille pour limiteur</i>	Casquillo para limitador
1382	Corona	<i>Worm wheel</i>	Schneckenrad	<i>Roue</i>	Corona
1383	Albero lento sporgente	<i>Plug-in output shaft</i>	Ausgangswelle	<i>Arbre lent solid</i>	Eje lento saliente

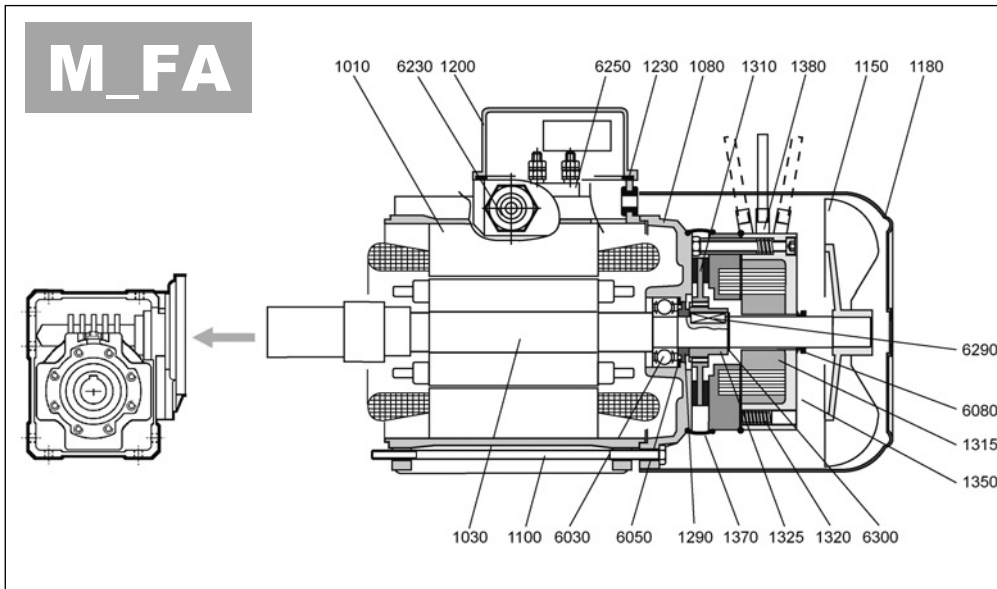
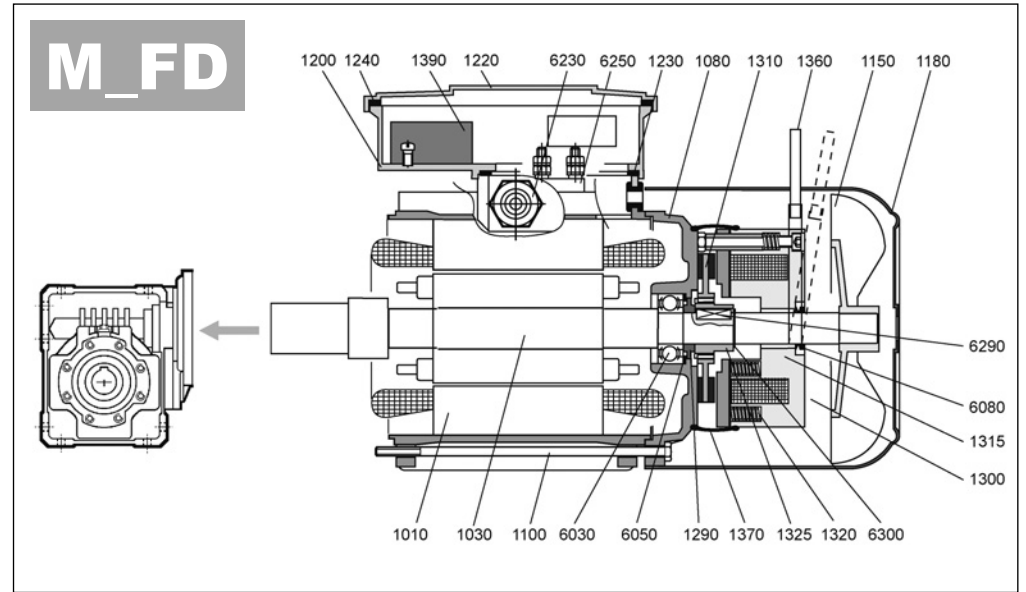
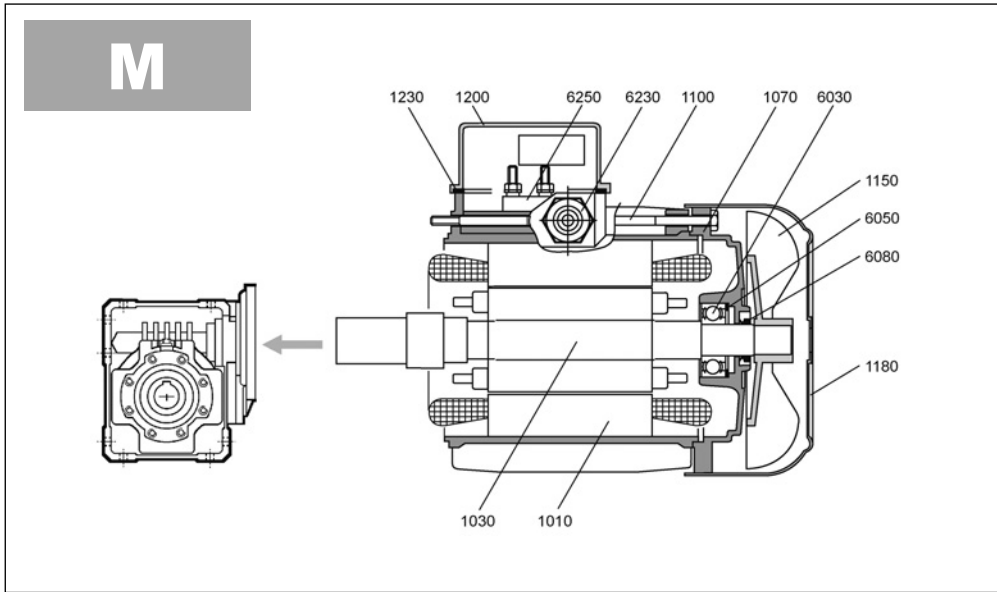

M	ref.	Denominazione	Description	Benennung	Dénomination	Denominación
M M_FD M_FA	1010	Statore	<i>Stator</i>	Stator	<i>Stator</i>	Estátor
	1030	Rotore	<i>Rotor</i>	Läufer	<i>Rotor</i>	Rotor
	1100	Tiranti	<i>Tie-rods</i>	Zugbolzen	<i>Entretoises</i>	Varillas
	1150	Ventola	<i>Fan</i>	Lüfterrad	<i>Ventilateur</i>	Ventilador
	1180	Copriventola	<i>Fan cowl</i>	Lüfterraddeckel	<i>Cache-ventilateur</i>	Cubreventilador
	1200	Scatola coprimorsettiera	<i>Conduit box</i>	Klemmkastendeckel	<i>Boîte cache-bornes</i>	Carcasa de la caja de bornes
	1230	Guarnizione scat. coprimors.	<i>Conduit box gasket</i>	Klemmkastendeckel dichtung	<i>Joint de la boîte à bornes</i>	Junta de la carcasa de la caja de bornes
	6030	Cuscinetto	<i>Bearing</i>	Lager	<i>Roulement</i>	Cojinete
	6050	Anello di compensazione	<i>Compensation ring</i>	Kompensationsring	<i>Bague de compensation</i>	Anillo de compensación
	6080	Anello V-RING	<i>V-ring</i>	V-Ring	<i>Bague V-ring</i>	Anillo V-ring
	6230	Pressacavo	<i>Cable gland</i>	Kabelhalter	<i>Presse-étoupe</i>	Prensacable
6250	Morsettiera	<i>Terminal board</i>	Klemmkasten	<i>Plaque à bornes</i>	Caja de bornes	
M	1070	Scudo	<i>Rear shield</i>	Schild	<i>Bouclier</i>	Protección
M_FD M_FA	1080	Scudo per mot. autofrenante	<i>Shield for brake motor</i>	Schild für Bremsmotor	<i>Bouclier pour moteur frein</i>	Protección para motor autofrenante
	1290	Distanziale	<i>Spacer ring</i>	Distanzstück	<i>Entretoise</i>	Distanciadador
	1360	Kit leva di sblocco	<i>Brake release kit</i>	Kit Handlüfterhebel	<i>Kit levier déblocage</i>	Kit de la palanca de desbloqueo
	1370	Kit guarnizioni freno	<i>Water/dust guard</i>	Kit Bremsdichtungen	<i>Kit bagues frein</i>	Kit de las guarniciones del freno
	6290	Linguetta (mozzo freno)	<i>Key (brake hub)</i>	Paßfeder (Bremsennabe)	<i>Clavette (moyeu frein)</i>	Chaveta (cubo del freno)
	6300	Anello seeger	<i>Circlip</i>	Seegerring	<i>Circlip</i>	Anillo Seeger
M_FD	1220	Coperchio scat.coprimorsett.	<i>Conduit box lid</i>	Klemmkastendeckel	<i>Couvercle boîte à bornes</i>	Tapa de la carcasa de la caja de bornes
	1240	Guarniz. coperchio coprim.	<i>Conduit box gasket</i>	Klemmkastendeckel dichtung	<i>Joint du couvercle de la boîte à bornes</i>	Junta de la tapa de la caja de bornes
	1300	Freno c.c. tipo FD	<i>d.c. brake type FD</i>	G.S.-Bremstyp FD	<i>Frein c.c type FD</i>	Freno cc tipo FD
	1390	Raddrizzatore	<i>ac/dc rectifier</i>	Gleichrichter	<i>Redresseur</i>	Rectificador
M_FA	1350	Freno c.a. tipo FA	<i>a.c. brake type FA</i>	D.S.-Bremstyp FA	<i>Frein c.a. type FA</i>	Freno ca tipo FA

BN

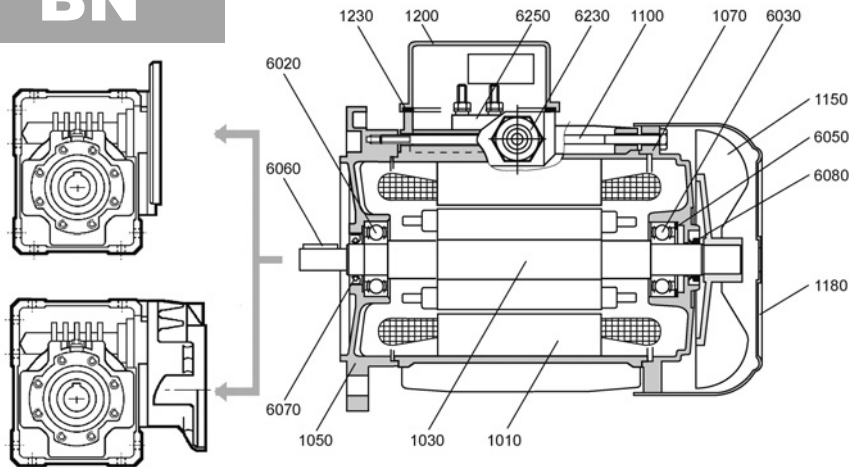

BN_FD

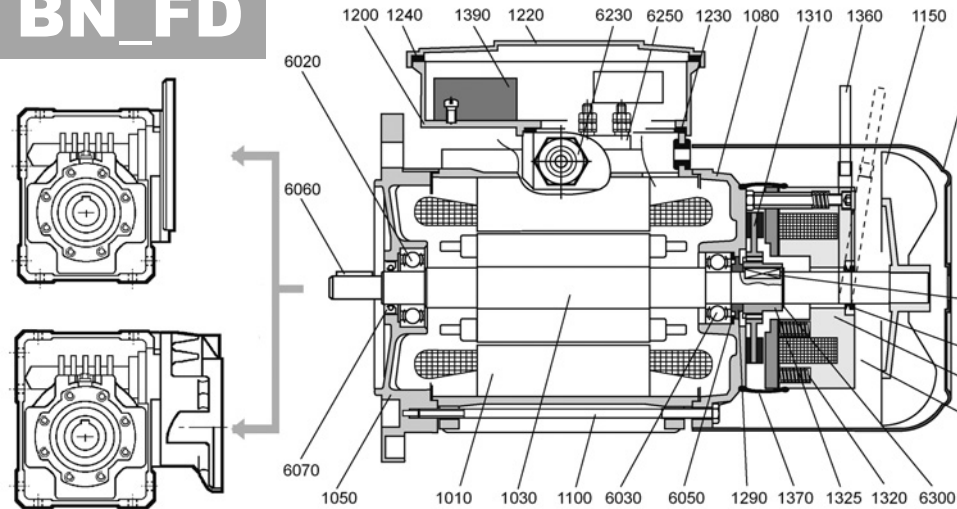

BN_FA

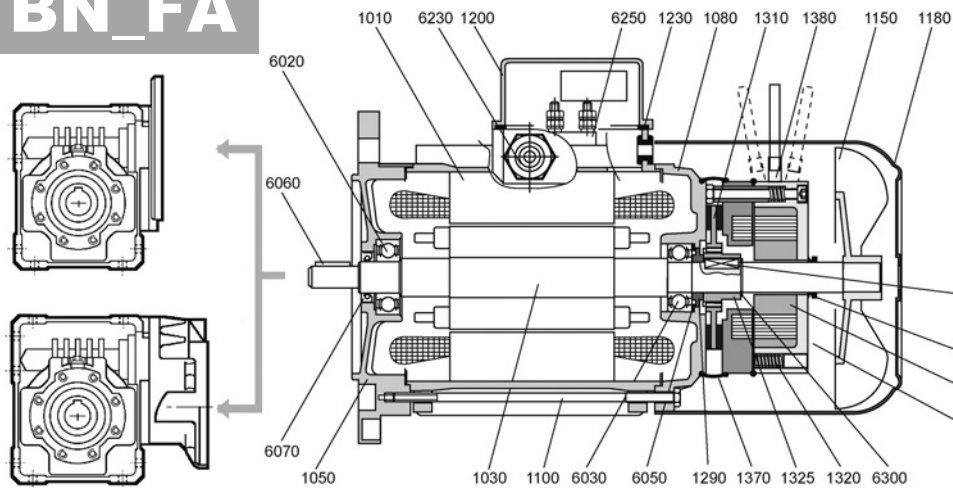

BN	ref.	Denominazione	Description	Benennung	Dénomination	Denominación
BN BN_FD BN_FA	1010	Statore	<i>Stator</i>	Stator	<i>Stator</i>	Estátor
	1030	Rotore	<i>Rotor</i>	Läufer	<i>Rotor</i>	Rotor
	1050	Flangia (B5/B14)	<i>Flange (B5/B14)</i>	Flansch (B5/B14)	<i>Bride (B5/B14)</i>	Brida (B5/B14)
	1100	Tiranti	<i>Tie-rods</i>	Zugbolzen	<i>Entretoises</i>	Varillas
	1150	Ventola	<i>Fan</i>	Lüfterrad	<i>Ventilateur</i>	Ventilador
	1180	Copriventola	<i>Fan cowl</i>	Lüfterraddeckel	<i>Cache-ventilateur</i>	Cubreventilador
	1200	Scatola coprimorsettiera	<i>Conduit box lid</i>	Klemmkastendeckel	<i>Boîte cache-bornes</i>	Carcasa de la caja de bornes
	1230	Guarnizione scat. coprimors.	<i>Conduit box gasket</i>	Klemmkastendeckel dichtung	<i>Joint de la boîte à bornes</i>	Junta de la carcasa de la caja de bornes
	6020	Cuscinetto	<i>Bearing</i>	Lager	<i>Roulement</i>	Cojinete
	6030	Cuscinetto	<i>Bearing</i>	Lager	<i>Roulement</i>	Cojinete
	6050	Anello di compensazione	<i>Compensation ring</i>	Kompensationsring	<i>Bague de compensation</i>	Anillo de compensación
	6060	Linguetta	<i>Key</i>	Paßfeder	<i>Clavette</i>	Chaveta
	6070	Anello di tenuta	<i>Oil seal</i>	Dichtring	<i>Bague d'étanchéité</i>	Anillo de estanqueidad
	6080	Anello V-RING	<i>V-ring</i>	V-Ring	<i>Bague V-ring</i>	Anillo V-ring
	6230	Pressacavo	<i>Cable gland</i>	Kabelhalter	<i>Presse-étoupe</i>	Prensacable
6250	Morsettiera	<i>Conduit box</i>	Klemmkasten	<i>Plaque à bornes</i>	Caja de bornes	
BN	1070	Scudo	<i>Rear shield</i>	Schild	<i>Bouclier</i>	Protección
BN_FD BN_FA	1080	Scudo per mot. autofrenante	<i>Shield for brake motor</i>	Schild für Bremsmotor	<i>Bouclier pour moteur frein</i>	Protección para motor autofrenante
	1290	Distanziale	<i>Spacer ring</i>	Distanzstück	<i>Entretoise</i>	Distanciador
	1360	Kit leva di sblocco	<i>Brake release kit</i>	Kit Handlüfterhebel	<i>Kit levier déblocage</i>	Kit de la palanca de desbloqueo
	1370	Kit guarnizioni freno	<i>Kit brake seals</i>	Kit Bremsdichtungen	<i>Kit bagues frein</i>	Kit de las guarniciones del freno
	6290	Linguetta (mozzo freno)	<i>Key (brake hub)</i>	Paßfeder (Bremsennabe)	<i>Clavette (moyeu frein)</i>	Chaveta (cubo del freno)
6300	Anello elastico	<i>Circlip</i>	Seegerring	<i>Circlip</i>	Anillo elástico	
BN_FD	1220	Coperchio scat.coprimorsett.	<i>Conduit box lid</i>	Klemmkastendeckel	<i>Couvercle boîte à bornes</i>	Tapa de la carcasa de la caja de bornes
	1240	Guarniz. coperchio coprim.	<i>Conduit box gasket</i>	Klemmkastendeckel dichtung	<i>Joint du couvercle de la boîte à bornes</i>	Junta de la tapa de la caja de bornes
	1300	Freno c.c. tipo FD	<i>d.c. brake type FD</i>	G.S.-Bremstyp FD	<i>Frein c.c type FD</i>	Freno cc tipo FD
	1390	Raddrizzatore	<i>ac/dc rectifier</i>	Gleichrichter	<i>Redresseur</i>	Rectificador
BN_FA	1350	Freno c.a. tipo FA	<i>a.c. brake type FA</i>	D.S.-Bremstyp FA	<i>Frein c.a. type FA</i>	Freno ca tipo FA

Opzioni motori elettrici:

Electric motors options:

Optionen - Elektromotoren:

Options moteurs électriques:

Opciones de los motores eléctricos:

Antiritorno

Back stop

Rücklaufsperre

Anti-retour

Antirretorno

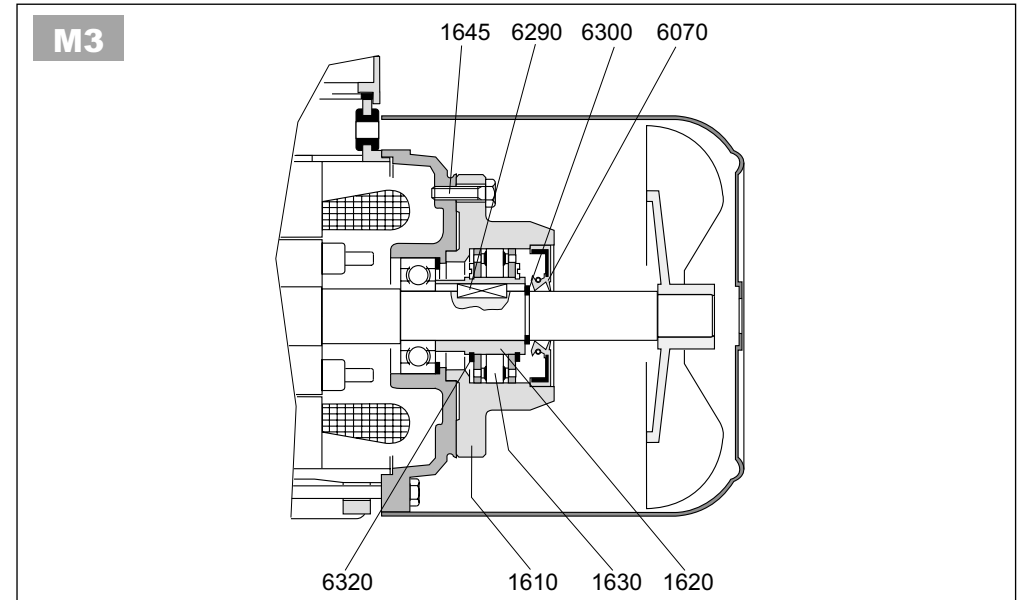
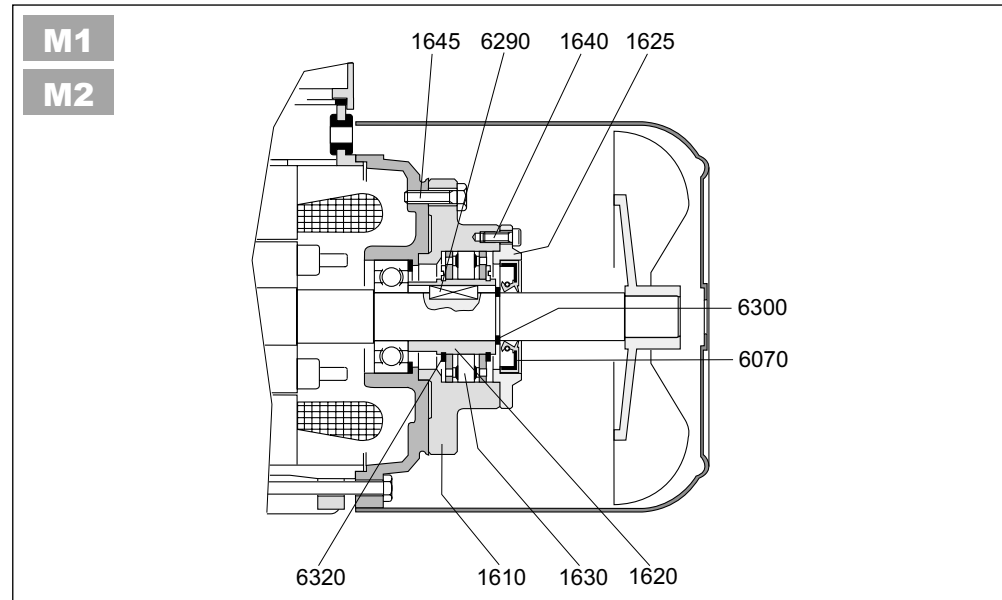

	ref.	Denominazione	Description	Benennung	Dénomination	Denominación
M1 - M2 - M3	1610	Boccola esterna	<i>External bushing</i>	Außenbuchse	<i>Douille externe</i>	Casquillo exterior
	1620	Boccola interna	<i>Internal bushing</i>	Innenbuchse	<i>Douille interne</i>	Casquillo interior
	1630	Ruota libera	<i>Freewheel</i>	Freilauf	<i>Roue libre</i>	Rueda interior
	1645	Vite di fissaggio	<i>Bolt</i>	Befestigungsschraube	<i>Vis de fixation</i>	Tornillo de fijación
	6070	Anello di tenuta	<i>seal ring</i>	Dichtungsring	<i>Joint d'étanchéité</i>	Anillo de estanqueidad
	6290	Linguetta	<i>Key</i>	Paßfeder	<i>Clavette</i>	Chaveta
	6300	Anello elastico	<i>Circlip</i>	Seegerring	<i>Circlip</i>	Anillo elástico
	6320	Anello elastico	<i>Circlip</i>	Seegerring	<i>Circlip</i>	Anillo elástico
M1 - M2	1625	Cappello	<i>Cap</i>	Deckel	<i>Capuchon</i>	Capuchón
	1640	Vite di fissaggio	<i>Screw</i>	Befestigungsschraube	<i>Vis de fixation</i>	Tornillo de fijación

**Servoventilatore / Separate supply forced ventilation
Servoventilator / Servo-ventilateur / Servoventilador**

**Volano / Flywheel
Schwungrad / Volant / Volante**

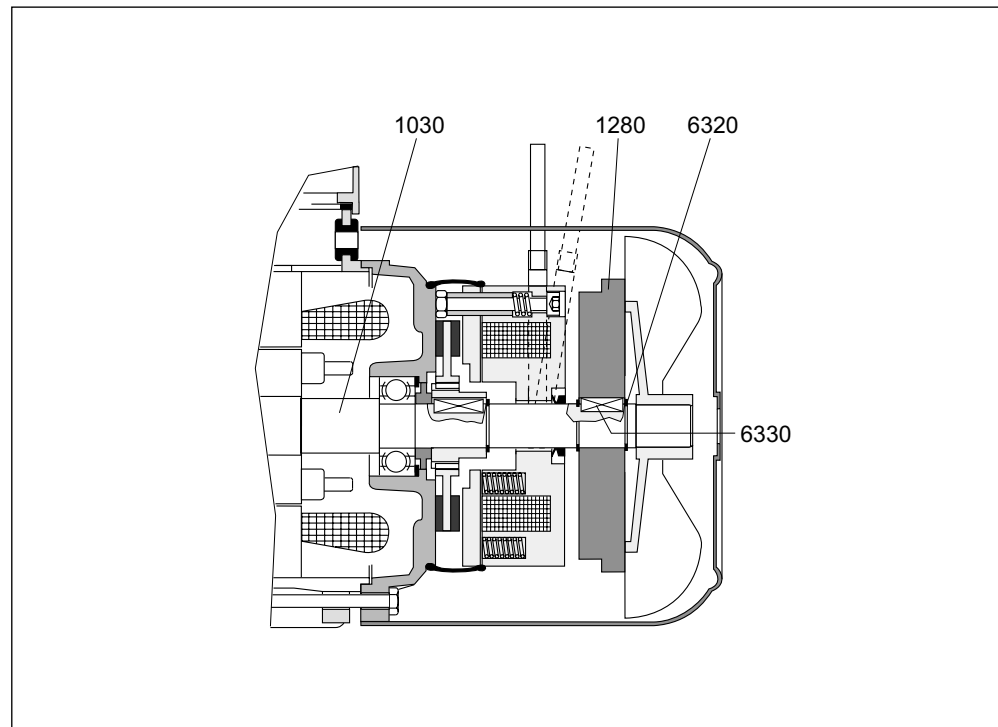
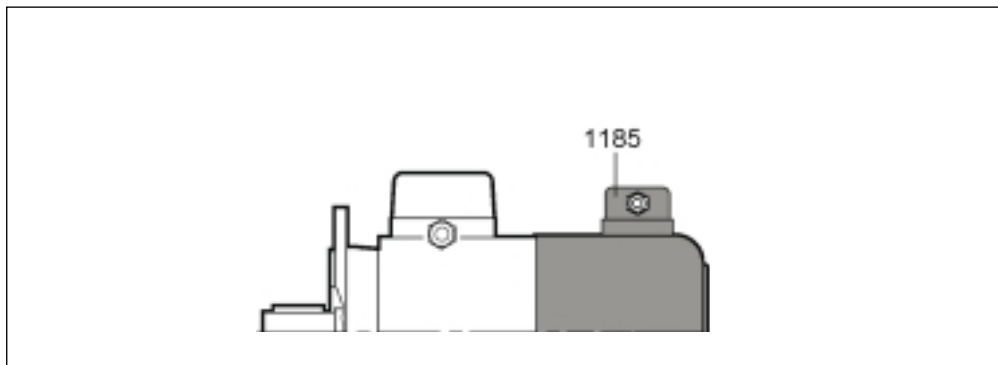

		V - Hz	In [A] 50/60 Hz
BN 71	M1	1x 230V - 50/60 Hz	0.14
BN 80	M2		0.14
BN 90			0.25
BN 100	M3		0.25
BN 112	M4S	3x 230/400 V - 50/60 Hz	0.26/0.15
BN 132	M4L		0.38/0.22

	ref.	Denominazione	Description	Benennung	Dénomination	Denominación
Servoventilatore / Forced cooling / Servoventilator / Servo-ventilateur / Servoventilador						
M - BN	1185	Servoventilatore	Forced cooling	Servoventilator	Servo-ventilateur	Servoventilador
Volano / Flywheel / Schwungrad / Volant / Volante						
BN_FA BN_FD	1030	Albero motore	Motor shaft	Motorwelle	Arbre moteur	Cigüeñal
	1280	Volano	Flywheel	Schwungrad	Volant	Volante
	6320	Anello elastico	Circlip	Seegerring	Circlip	Anillo elástico
	6330	Linguetta	Key	Paßfeder	Clavette	Chaveta

R2

Questa pubblicazione annulla e sostituisce ogni precedente edizione o revisione. Ci riserviamo il diritto di apportare modifiche senza preavviso. È vietata la produzione anche parziale senza autorizzazione.

This publication supersedes and replaces any previous edition and revision. We reserve the right to implement modifications without notice. This catalogue cannot be reproduced, even partially, without prior consent.

Diese Veröffentlichung annulliert und ersetzt jeder hergehende Edition oder Revision. BONFIGLIOLI behält sich das Recht vor, Änderungen ohne vorherige Informationen durchzuführen.

Cette publication annule et remplace toutes les autres précédentes. Nous nous réservons le droit d'apporter toutes modifications à nos produits. La reproduction et la publication partielle ou totale de ce catalogue est interdite sans notre autorisation.

Esta publicación anula y sustituye todas las ediciones o revisiones anteriores. Queda reservado el derecho de aportar modificaciones sin previo aviso. Se prohíbe la reproducción incluso parcial sin autorización expresa.



www.bonfiglioli.com

