

Doppeltwirkende Vorschubölbremse Double-Acting Speed Controls

Régulateurs de Vitesse Double Sens · Regolatori di Velocità a Doppio Effetto
Controladores de Velocidad de Doble Efecto



D

Präzise Einstellbarkeit in Zug- und Druckrichtung Stufenlose Einstellung über den gesamten Dämpfungsbereich

Dämpfung	Doppeltwirkend
Oberflächenschutz	Gehäuse: Stahl verzinkt
Lange Lebensdauer	Kolbenstange hartverchromt
Temperaturbereich	-20°C - +80°C
RoHS konform	Richtlinie 2002/95/EG

GB

Precise adjustment in Push- and Pull direction Continuous adjustment over the entire stroke

Deceleration	Double-acting
Surface protection	Housing: zinc plated steel
Extended life time	Piston rod: hard-chrome plated
Temperature	-20°C - +80°C
RoHS compliant	Directive 2002/95/E

F

Réglage précis dans les deux sens de la course Réglage continu sur toute la course

Amortissement	Double effet
Protection de la surface	Corps: acier zingué
Longévité	Tige de piston: chromée dur
Températures	-20°C - +80°C
RoHS compliantes	Directive 2002/95/EC

I

Regolazione accurata nei due sensi della corsa Regolazione continua lungo l'intera corsa

Smorzamento	Doppio effetto
Superficie di protezione	Corpo: acciaio zincato
Lunga durata	Stelo del pistone: acciaio cromato
Temperaturbereich	-20°C - +80°C
RoHS compliant	Direttiva 2002/95/EC

E

Ajuste de precisión en ambas direcciones de la carrera Ajuste continuo en toda la carrera

Amortiguación	De doble efecto
Protección de Superficie	Carcasa: acero zincado
Larga vida útil	Vástago del émbolo de cromado duro
Temperaturas	-20°C - +80°C
RoHS y que cumplan	Directiva 2002/95/CE

E1



E2

größere Einstellschraube
larger adjustment screw

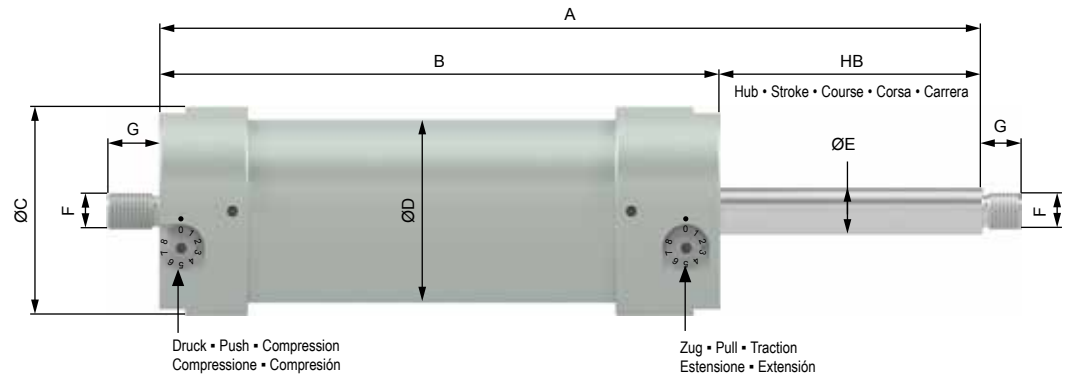
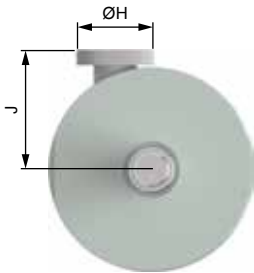

Befestigung / Mounting
Fixation / Fissaggio

Soporte
G0



Befestigung / Mounting
Fixation / Fissaggio

Soporte
K0

Festanschlag 1 mm vor den Hubenden vorsehen / 1 mm end stop required in both stroke directions
Butée de fin de course de 1 mm nécessaire dans les deux sens de course / Necessità di un finecorsa da 1 mm in entrambe le direzioni di corsa
Se requiere un tope final de 1 mm en ambas direcciones de carrera

LEISTUNGEN • PERFORMANCE • CARATTERISTICHE TECNICHE • CARACTERÍSTICAS TÉCNICAS

	Hub - Stroke Course Corsa Carrera	Zug - Pull Traction Estensione Extensión	Druck - Push Pression Compresione Compresión	A	B	ØC	ØD	ØE	F	G	ØH	J	Gewicht - Weight Poids - Peso Peso
	mm	N max.	N max.	mm	mm	mm	mm	mm	mm	mm	mm	mm	kg
WM-VD 50-050	50	11.000	11.000	196	146	60	50	14	M10	12	22	37,5	2,2
WM-VD 50-100	100	11.000	11.000	296	196	60	50	14	M10	12	22	37,5	2,6
WM-VD 50-150	150	11.000	11.000	396	246	60	50	14	M10	12	22	37,5	3,1
WM-VD 50-200	200	11.000	11.000	496	296	60	50	14	M10	12	22	37,5	3,5
WM-VD 50-250	250	11.000	11.000	596	346	60	50	14	M10	12	22	37,5	4,0
WM-VD 50-300	300	11.000	11.000	696	396	60	50	14	M10	12	22	37,5	4,4
WM-VD 70-100	100	18.000	18.000	314	214	80	70	18	M14x1,5	20	30	48,0	4,9
WM-VD 70-150	150	18.000	18.000	414	264	80	70	18	M14x1,5	20	30	48,0	5,2
WM-VD 70-200	200	18.000	18.000	514	314	80	70	18	M14x1,5	20	30	48,0	5,8
WM-VD 70-300	300	18.000	18.000	714	414	80	70	18	M14x1,5	20	30	48,0	7,0
WM-VD 70-400	400	18.000	15.000	914	514	80	70	18	M14x1,5	20	30	48,0	8,2
WM-VD 70-500	500	18.000	12.000	1114	614	80	70	18	M14x1,5	20	30	48,0	9,4

Bestellbeispiel • Ordering Information • Exemple de commande • Esempio d'ordinazione • Ejemplo de pedido

WM-VD 70-100-E1-K1G3-C

WM	Weforma
VD	Vorschubölbremse, doppelwirkend / Speed control, double-acting / Régulateurs de vitesse, double effet Regolatori di velocità, a doppio effetto / Controlador de velocidad de doble efecto
70	Baugröße / Size / Dimension / Dimensione / Dimensión
100	Hub / Stroke / Course / Corsa / Carrera
E1 / E2	E1 = Einstellschraube standard, E2 = größere Einstellschraube / E1 = Adjusting screw standard, E2 = Larger adjustment screw E1 = Vis de réglage standard, E2 = Vis de réglage plus grande / E1 = Vita di regolazione standard, E2 = Vita di regolazione più grande E1 = Tornillo de ajuste estándar, E2 = Tornillo de ajuste más grande
K1	Kolbenstange - Gelenkauge / Piston rod - Male rod clevis / Tige de piston - Tête de chape / Stelo del pistone - Attacco a cerniera maschio / Vástago del émbolo - Charnela macho
G3	Gehäuse - Gabelkopf / Housing - Female rod clevis / Corps - Embout à rotule (femelle) / Ingombri - Forcella femmina / Carcasa - Charnela hembra
C	Dämpfung: A=Druck, B=Zug, C=Druck und Zug / Type of deceleration: A=push, B=pull, C=push and pull Type d'amortissement: A=compression, B=traction, C=compression/traction / Tipo di smorzamento: A=compressione, B=estensione, C=compressione e estensione / Tipo de amortiguación: A = compresión, B = extensión, C = compresión/extensión

WM-VD 85 / 110

E1

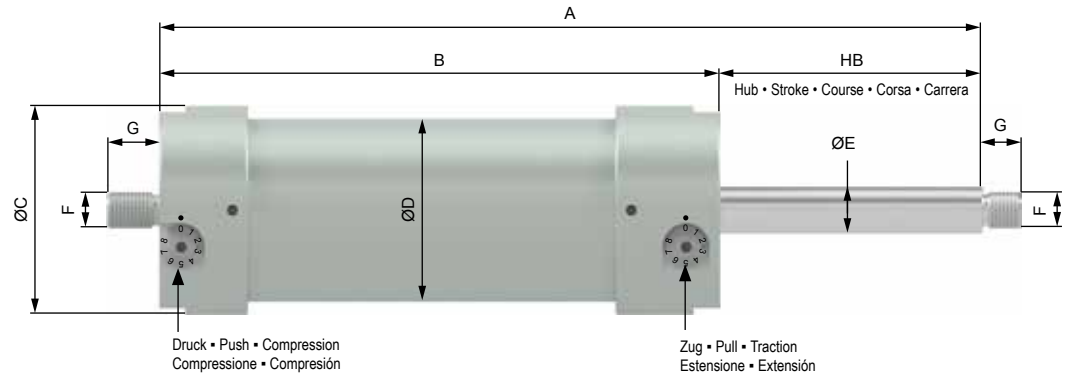

E2

größere Einstellschraube optional
larger adjustment screw optional

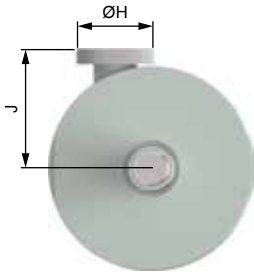

Befestigung / Mounting

Fixation / Fissaggio

Soporte

G0



Befestigung / Mounting

Fixation / Fissaggio

Soporte

K0

Festanschlag 1 mm vor den Hubenden vorsehen / 1 mm end stop required in both stroke directions

Butée de fin de course de 1 mm nécessaire dans les deux sens de course / Necessità di un finecorsa da 1 mm in entrambe le direzioni di corsa
Se requiere un tope final de 1 mm en ambas direcciones de carrera

LEISTUNGEN - PERFORMANCE - CARATTERISTICHE TECNICHE - CARACTERÍSTICAS TÉCNICAS

	Hub - Stroke Course Corsa Carrera	Zug - Pull Traction Estensione Extensión	Druck - Push Pressure Compressione Compresión	A	B	ØC	ØD	ØE	F	G	ØH	J	Gewicht - Weight Poids - Peso Peso
	mm	N max.	N max.	mm	mm	mm	mm	mm	mm	mm	mm	mm	kg
WM-VD 85-100	100	50000	50000	361	261	95	85	28	M24x2	35	30	54,4	9,2
WM-VD 85-150	150	50000	40000	461	311	95	85	28	M24x2	35	30	54,4	10,4
WM-VD 85-200	200	50000	30000	561	361	95	85	28	M24x2	35	30	54,4	11,5
WM-VD 85-250	250	50000	20000	661	411	95	85	28	M24x2	35	30	54,4	12,6
WM-VD 85-300	300	50000	15000	761	461	95	85	28	M24x2	35	30	54,4	13,7
WM-VD 85-400	400	50000	10000	961	561	95	85	28	M24x2	35	30	54,4	15,7
WM-VD 85-500	500	50000	9000	1161	661	95	85	28	M24x2	35	30	54,4	18,2
WM-VD 85-600	600	50000	7000	1361	761	95	85	28	M24x2	35	30	54,4	20,5
WM-VD 85-700	700	50000	4000	1561	861	95	85	28	M24x2	35	30	54,4	22,7
WM-VD 110-100	100	90000	90000	410	310	120	110	32	M30x2	40	50	67,0	19,5
WM-VD 110-150	150	90000	80000	510	360	120	110	32	M30x2	40	50	67,0	21,3
WM-VD 110-200	200	90000	75000	610	410	120	110	32	M30x2	40	50	67,0	23,2
WM-VD 110-250	250	90000	70000	710	460	120	110	32	M30x2	40	50	67,0	25,1
WM-VD 110-300	300	90000	50000	810	510	120	110	32	M30x2	40	50	67,0	27,0
WM-VD 110-400	400	90000	40000	1010	610	120	110	32	M30x2	40	50	67,0	30,8
WM-VD 110-500	500	90000	30000	1210	710	120	110	32	M30x2	40	50	67,0	34,5
WM-VD 110-600	600	90000	20000	1410	810	120	110	32	M30x2	40	50	67,0	38,3
WM-VD 110-700	700	90000	15000	1610	910	120	110	32	M30x2	40	50	67,0	42,0

- 1** Gelenkauge • Male rod clevis
Tête de chape (male)
Attacco a cerniera maschio
Charnela macho

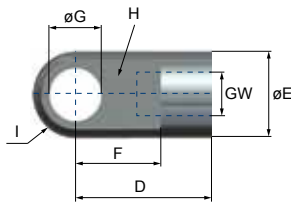

- 2** Winkelgelenk • Angle joint
Joint à angle • Snodo angolare
Charnela articulada (DIN 71802)

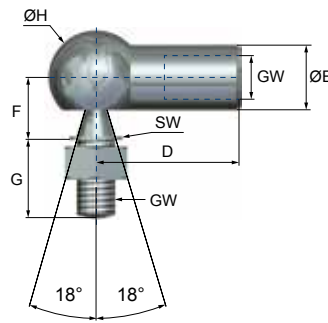

	Kraft- Force Forza- Fuerza
WM-VD 32 / 36	1.230 N
WM-VD 50	1.900 N
WM-VD 70	3.200 N

- 3** Gabelkopf • Female rod clevis
Embout à rotule (femelle)
Forcella femmina
Charnela hembra (DIN 71752)

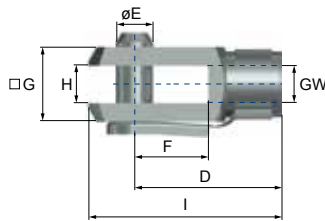

WM-VD 32 / 36	M8
WM-VD 50	M10
WM-VD 70	M14x1,5
WM-VD 80 / 85	M24x2

- 3** Gabelkopf • Female rod clevis
Embout à rotule (femelle)
Forcella femmina
Charnela hembra (DIN 71752)

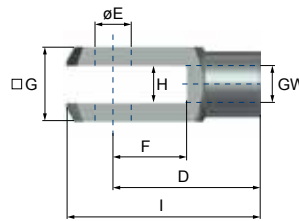

WM-VD 110	M30x2
-----------	-------

- 4** Gelenkkopf • Spherical end bearing
Embout à rotule • Forcella snodata
Charnela macho articulada
(DIN 648, Maßreihe / Series K,
Maßreihe E auf Anfrage / Series E on enquiry)

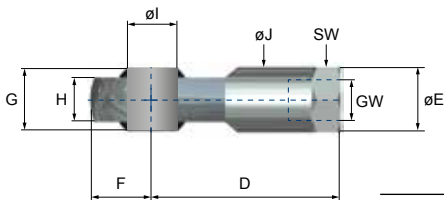

	Kraft- Force Forza- Fuerza
WM-VD 32 / 36	7.000 N
WM-VD 50	10.400 N
WM-VD 70	22.400 N
WM-VD 85	45.400 N
WM-VD 110	55.000 N

- 5** Schwenkflansch • Clevis flange • Flasque articulé
Flangia oscillante • Brida giratoria

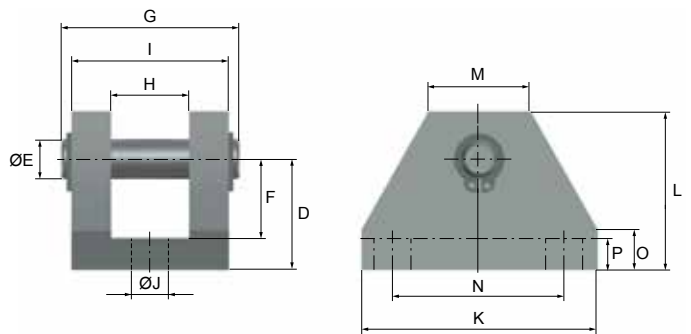

nur in Kombination mit Gelenkkopf (4) verwenden • only use in combination with spherical end bearing (4)
à utiliser uniquement avec la Embout à rotule (4) • Impiegare solo in combinazione con forcella snodata (4)
Utilizar exclusivamente en combinación con charnela macho articulada (4)

ABMESSUNGEN • DIMENSIONS • DIMENSIONI • DIMENSIONES

	GW* / GW1	D	ØE	F	G	H	I	SW	4	GW*	D	ØE	F	G	H	I	J	SW	K	L	M	N	O	P		
																									mm	mm
1	WM-VD 32 / 36	M8	19	14	12	8,1	10	7	-	4	WM-VD 32 / 36	M8	36	16	12	12	9	8	12,5	13	-	-	-	-	-	
	WM-VD 50	M10	27	18	12	8,1	10	9	-		WM-VD 50	M10	43	19	14	14	10,5	10	15	17	-	-	-	-	-	
	WM-VD 70	M14x1,5	40	25	21	14,1	14	12,5	-		WM-VD 70	M14x1,5	57	26	18	19	13	14	20	22	-	-	-	-	-	
	WM-VD 80 / 85	M24x2	60	40	35	25	25	20	-		WM-VD 80 / 85	M24x2	94	42	30	31	22	25	33,5	36	-	-	-	-	-	
	WM-VD 110	M30x2	80	55	45	30	37	27,5	-		WM-VD 110	M30x2	110	55	35,5	37	25	30	40	41	-	-	-	-	-	
2	WM-VD 32 / 36	M8	30	13	13	16	20	-	11	5	WM-VD 50	M10	28	10	20	50	20	40	8,5	-	60	40	26	46	10	8
	WM-VD 50	M10	35	16	16	19	24	-	13		WM-VD 70	M14x1,5	28	14	20	44	20	40	8,5	-	60	40	26	46	10	8
	WM-VD 70	M14x1,5	45	22	20	28	30	-	16		WM-VD 80 / 85	M24x2	45	25	33	70	32	65	13	-	90	65	40	70	20	12
3	WM-VD 32 / 36	M8	32	8	16	16	8	42	-																	
	WM-VD 50	M10	40	10	20	20	10	52	-																	
	WM-VD 70	M14x1,5	56	14	27	27	14	72	-																	
	WM-VD 80 / 85	M24x2	100	25	50	50	25	132	-																	
	WM-VD 110	M30x2	120	30	60	60	30	160	-																	