

Doppeltwirkende Vorschubölbremse Double-Acting Speed Controls

Régulateurs de Vitesse Double Sens · Regolatori di Velocità a Doppio Effetto
Controladores de Velocidad de Doble Efecto



D

Präzise Einstellbarkeit in Zug- und Druckrichtung Stufenlose Einstellung über den gesamten Dämpfungsbereich

Dämpfung	Doppeltwirkend
Oberflächenschutz	Gehäuse: Aluminium eloxiert
Lange Lebensdauer	Kolbenstange hartverchromt
Temperaturbereich	-20°C - +80°C
RoHS konform	Richtlinie 2002/95/EG

GB

Precise adjustment in Push- and Pull direction Continuous adjustment over the entire stroke

Deceleration	Double-acting
Surface protection	Housing: anodised aluminium
Extended life time	Piston rod: hard-chrome plated
Temperature	-20°C - +80°C
RoHS compliant	Directive 2002/95/E

F

Réglage précis dans les deux sens de la course Réglage continu sur toute la course

Amortissement	Double effet
Protection de la surface	Corps: aluminium anodisé
Longévité	Tige de piston: chromée dur
Températures	-20°C - +80°C
RoHS compliantes	Directive 2002/95/EC

I

Regolazione accurata nei due sensi della corsa Regolazione continua lungo l'intera corsa

Smorzamento	Doppio effetto
Superficie di protezione	Corpo: Alluminio anodizzato
Lunga durata	Stelo del pistone: acciaio cromato
Temperaturbereich	-20°C - +80°C
RoHS compliant	Direttiva 2002/95/EC

E

Ajuste de precisión en ambas direcciones de la carrera Ajuste continuo en toda la carrera

Amortiguación	De doble efecto
Protección de Superficie	Carcasa: aluminio anodizado
Larga vida útil	Vástago del émbolo de cromado duro
Temperaturas	-20°C - +80°C
RoHS y que cumplan	Directiva 2002/95/CE

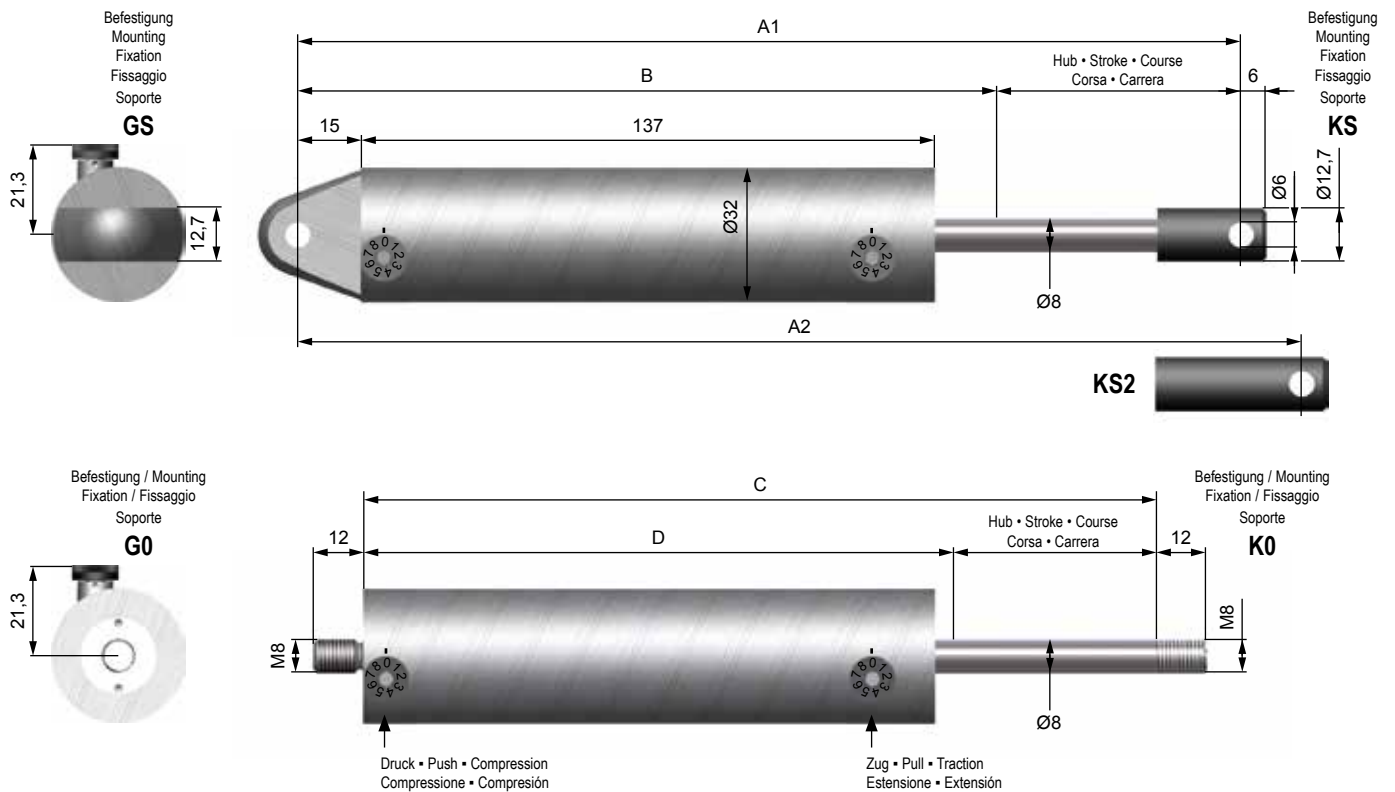

Zubehör Seite 189 • Accessories Pages 189 • Accessoires Page 189 • Accessori Pagina 189 • Accesorios Página 189

LEISTUNGEN • PERFORMANCE • CARATTERISTICHE TECNICHE • CARACTERÍSTICAS TÉCNICAS

	Hub Stroke Course Corsa Carrera	Zug Pull Traction Estensione Extensión	Druck Push Pression Compressione Compresión	Zug - Druck Pull - Push Traction - Pression Estensione - Compressione Extensión - Compresión	Vorschubgeschwindigkeit Speed rates Vitesses de régulation Velocità regolata Velocidad de avance	A1	A2	B	C	D	Gewicht Weight Poids Peso Peso
	mm	N max.	N max.	N min.	m/min	mm	mm	mm	mm	mm	g
WM-VD 32 - 050	50	2000	2000	40	0,015 - 40	225	250	175	190	140	370
WM-VD 32 - 075	75	2000	2000	40	0,015 - 40	275	300	200	240	165	420
WM-VD 32 - 100	100	2000	1700	40	0,015 - 40	325	350	225	290	190	470
WM-VD 32 - 150	150	2000	1400	40	0,015 - 40	425	450	275	390	240	570
WM-VD 32 - 200	200	2000	1000	40	0,015 - 40	525	550	325	490	290	670
WM-VD 32 - 250	250	2000	600	40	0,015 - 40	625	650	375	590	340	770

Bestellbeispiel • Ordering Information • Exemple de commande • Esempio d'ordinazione • Ejemplo de pedido

WM-VD 32-100-K2G4-C

WM	Weforma
VD	Vorschubölbremse, doppeltwirkend / Speed control, double-acting / Régulateurs de vitesse, double effet Regolatori di velocità, a doppio effetto / Controlador de velocidad de doble efecto
32	Baugröße / Size / Dimension / Dimensione / Dimensión
100	Hub / Stroke / Course / Corsa / Carrera
K2	Kolbenstange - Winkelgelenk / Piston rod - Angle joint / Tige de piston - Joint à angle Stelo del pistone - Snodo angolare / Vástago del émbolo - charnela articulada
G4	Gehäuse - Gelenkkopf / Housing - Spherical end bearing / Corps - Embout à rotule Ingombri - Forcella snodata / Carcasa - charnela macho articulada
C	Dämpfung: A=Druck, B=Zug, C=Druck und Zug / Type of deceleration: A=push, B=pull, C=push and pull Type d'amortissement: A=compression, B=traction, C=compression/traction Tipo di smorzamento: A=compressione, B=estensione, C=compressione e estensione Tipo de amortiguación: A = compresión, B = extensión, C = compresión/extensión