

SENSOR FUNCTIONS	
S1	Tool holder is hooked up correctly
S2	Collet is open
S3	Speed sensor 2 high/rev
S5	Piston in upper position

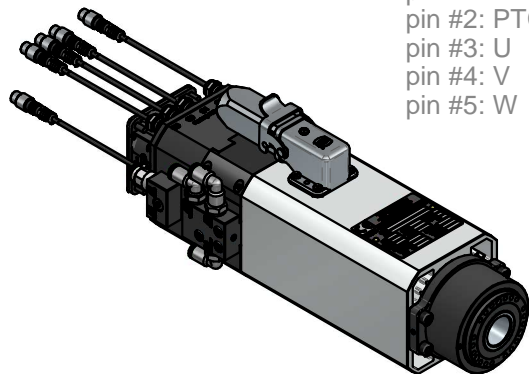

PLUG CONNECTION
 pin #1: PTC
 pin #2: PTC
 pin #3: U
 pin #4: V
 pin #5: W

Power [kW]	1.1	Duty Cycle	S6-60%	Base speed [rpm]	18000	Base freq. [Hz]	300	Base voltage Δ [V]	220	Base voltage Y [V]		Protection	IP54	Ins. Cl.	F
Min speed [rpm]	6000	Max speed [rpm]	24000	Max freq. [Hz]	400	Absorb. Δ [A]	4.3	Absorb. Y [A]		Part number on nameplate	COMTC410001				
Balancing according to ISO 1940 - G2.5 @ 24000 rpm	Balancing type			tool type		tool type		Peso / weight		5.92 kg					

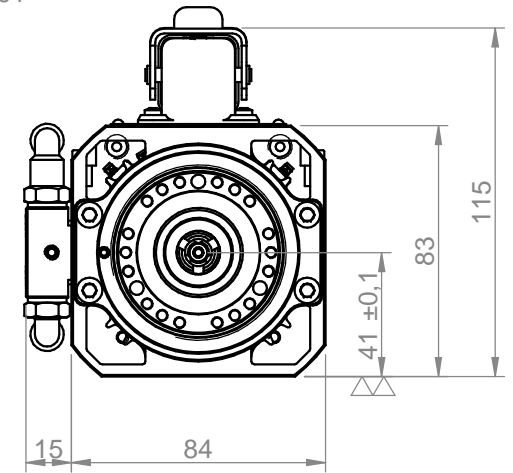
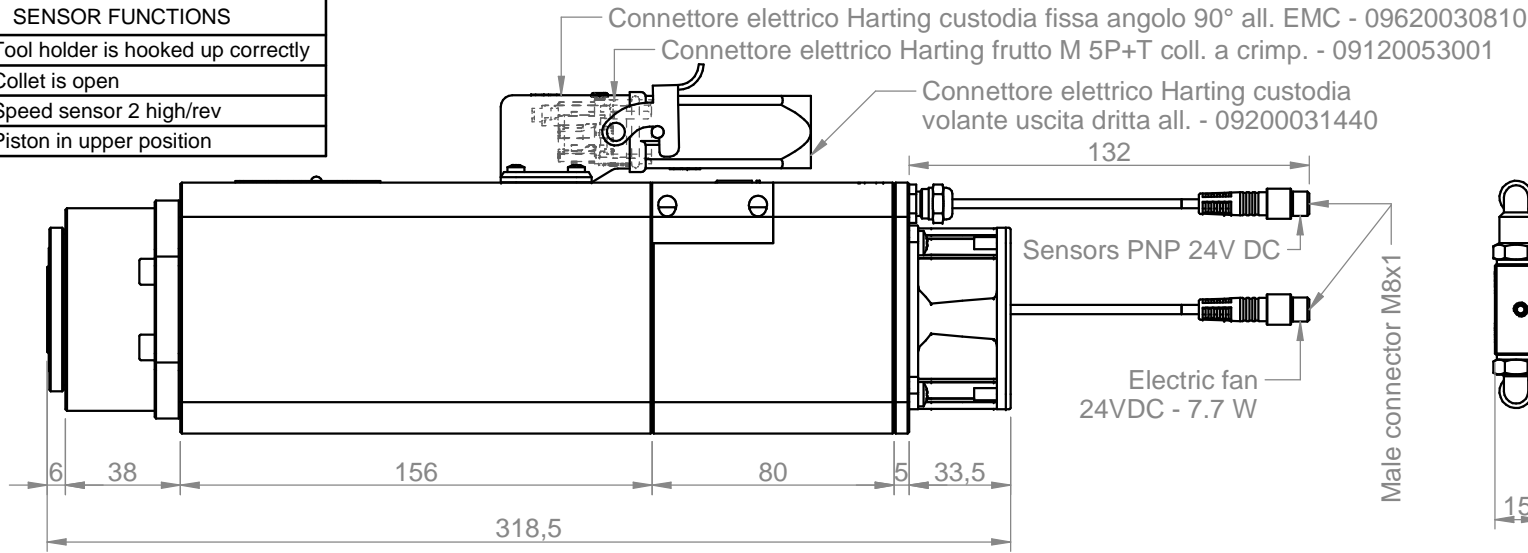

Teknomotor S.r.l.
 Via Argenege 31, I-32038 Quero Vas (BL)
 www.teknomotor.com

Tolleranze non quotate: UNI EN 22768 fH
 Smussi non quotati: 0.5mm

$\nabla = 0.8 \nabla$ $\nabla = 3.2 \nabla$ $\nabla = 12.5 \nabla$ $\sim = \nabla$

rev. n°	description	date	signature
00	Emissione	10/05/2017	D. Bottarel

Title		ATC41-A-DB-ISO20-SN	
Customer		Catalogo	
Drawing code		COMTC410001	

drawn - date	approved - date	checked - date	sostituisce il
D. Bottarel - 10/05/2017	S. Perli - 10/05/2017	S. Perli - 10/05/2017	sostituito dal

foglio / sheet	scala			A4
1 / 1	n.d.			