



Bonfiglioli
Tecnoingranaggi

LCK series

Precision right-angle gearboxes



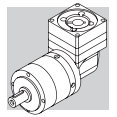

LC



$3 \leq i \leq 100$

$18 \text{ Nm} \leq M_{n2} \leq 300 \text{ Nm}$

LCK

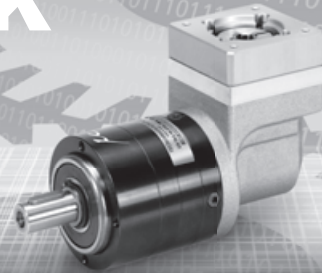

$6 \leq i \leq 100$

$10 \text{ Nm} \leq M_{n2} \leq 300 \text{ Nm}$

MP

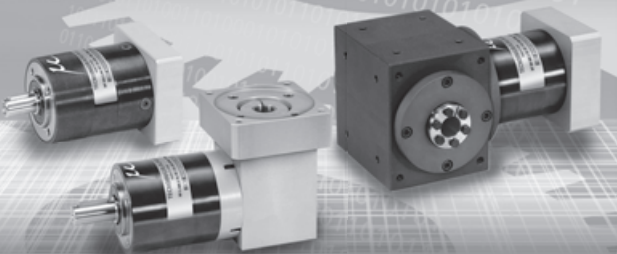

$3 \leq i \leq 1000$

$12 \text{ Nm} \leq M_{n2} \leq 1000 \text{ Nm}$

TR

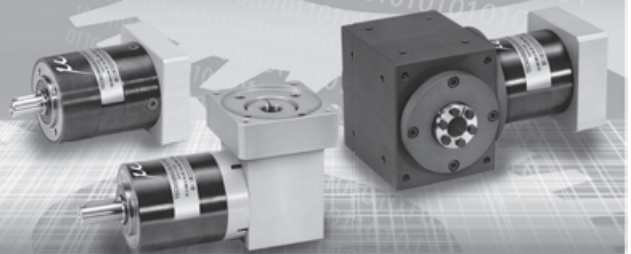

$3 \leq i \leq 1000$

$12 \text{ Nm} \leq M_{n2} \leq 1000 \text{ Nm}$

SL

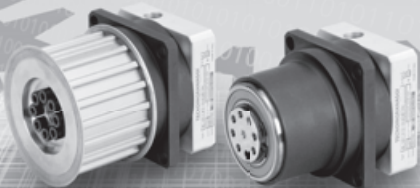

$3 \leq i \leq 10$

$18 \text{ Nm} \leq M_{n2} \leq 110 \text{ Nm}$

KR

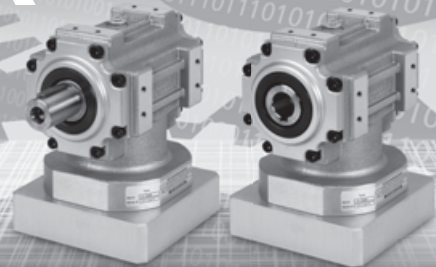

$i = 1, 2, 5$

$3 \text{ Nm} \leq M_{n2} \leq 120 \text{ Nm}$

TQ

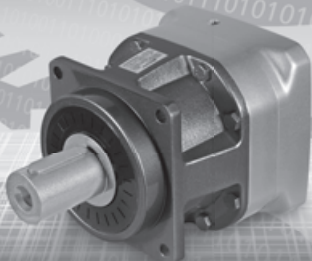

$3 \leq i \leq 100$

$30 \text{ Nm} \leq M_{n2} \leq 800 \text{ Nm}$

TQK

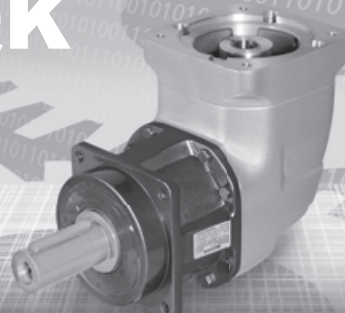

$6 \leq i \leq 200$

$30 \text{ Nm} \leq M_{n2} \leq 800 \text{ Nm}$

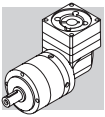

SYMBOLS, UNITS AND DEFINITIONS

Values depending on the **APPLICATION**

term	u.m.	definition
A₂	[N]	Thrust force on output shaft
R₂	[N]	Radial force on output shaft
ED	[min]	Loading time
ED%	[%]	Loading time %
L_{10h}	[h]	Bearings' basic rating life
M₁ PEAK	[Nm]	Maximum input torque (usually motor)
M_{2(1) ... M_{2(n)}}	[Nm]	Output torque at each of the time periods t ₁ ... t _n
M₂ EQU	[Nm]	Equivalent output torque
M₂ MAX	[Nm]	Maximum output torque in case of emergency
M_{T2} MAX	[Nm]	Maximum tilting moment on output shaft
n₂	[min ⁻¹]	Output speed
n_{2(1) ... n_{2(n)}}	[min ⁻¹]	Output speed based on the time periods t ₁ ... t _n
n₂ EQU	[min ⁻¹]	Equivalent output speed
n₂ MAX	[min ⁻¹]	Maximum output speed
T	[C°]	Ambient temperature
t₁ ... t_n	[s]	Time periods of motion
t_Σ	[s]	Cycle duration including pause
Z	[1/h]	Cycle number per hour

Values depending on the **GEAR DRIVE SELECTION**

term	u.m.	definition
A₂ max	[N]	Admissible thrust force
A_{2'} max	[N]	Thrust force acting simultaneously with the rated radial force
R₂ max	[N]	Admissible radial force at midpoint of output shaft
C_B	[Nm]	Constant for bearing's lifetime calculation
C_t	$\left[\frac{\text{Nm}}{\text{arcmin}} \right]$	Torsional stiffness
f_n	—	Speed factor
f_z	—	Cycle factor
f_T	—	Temperature correction factor
i	—	Gearbox ratio
J_G	[kgcm ²]	Mass moment of inertia of the gearhead
K_n	—	Speed constant
L_Z	[mm]	Factor for bearing's lifetime calculation
M_{T2} max	[Nm]	Permissible tilting moment
M_{n 2}	[Nm]	Rated output torque
M_{a 2}	[Nm]	Maximum acceleration output torque
M_{p 2}	[Nm]	Emergency stop output torque
n₁ max	[min ⁻¹]	Maximum momentary input speed. The speed the unit can be driven at occasionally and in non-repetitive conditions. For cycle duty type S5, it cannot be applied continuously for more than 30 seconds
p	—	Bearing lifetime exponent
η	[%]	Gear efficiency
φ_S	[arcmin]	Standard backlash is calculated in static conditions and with the application of a torque equal to 2% of the gear unit rated torque
φ_R	[arcmin]	Reduced backlash is calculated in static conditions and with the application of a torque equal to 2% of the gear unit rated torque

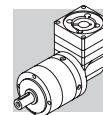

SUMMARY



1 General information	4
1.1 Selecting the gear unit	4
1.2 Service life of bearings	6
2 Features of LCK series	8
3 Ordering code	9
4 Dimensions and technical specifications	10
LCK 050	10
LCK 070	12
LCK 090	14
LCK 120	16
LCK 155	18

Revisions

Refer to page 20 for the catalogue revision index.

Visit www.tecnoingranaggi.it to search for catalogues with up-to-date revisions.

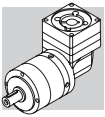

1 GENERAL INFORMATION

1.1 SELECTING THE GEAR UNIT

(a)	Ratio	i	—	$i = \frac{n_1}{n_2}$														
(b)	Equivalent output torque	$M_{2\text{ EQU}}$	[Nm]	$M_{2\text{ EQU}} = \sqrt[3]{\frac{n_{2(1)} \cdot t_1 \cdot M_{2(1)} ^3 + \dots + n_{2(n)} \cdot t_n \cdot M_{2(n)} ^3}{n_{2(1)} \cdot t_1 + \dots + n_{2(n)} \cdot t_n}}$														
(c)	Equivalent output speed	$n_{2\text{ EQU}}$	[min ⁻¹]	$n_{2\text{ EQU}} = \frac{n_{2(1)} \cdot t_1 + n_{2(2)} \cdot t_2 + \dots + n_{2(n)} \cdot t_n}{t_\Sigma}$														
(d)	Speed factor	f_n	—	<p>If $\frac{K_n}{n_{2\text{ EQU}} \cdot i} \geq 1 \Rightarrow f_n = 1$</p> <p>If $\frac{K_n}{n_{2\text{ EQU}} \cdot i} < 1 \Rightarrow f_n = \text{Obtain from diagram}$</p>														
(e)	Loading time %	ED%	[%]	$ED\% = \frac{t_1 + t_2 + \dots + t_n}{t_\Sigma} \cdot 100$														
	Loading time	ED	[min]	$ED = t_1 + t_2 + \dots + t_n$														
(f)	Cycle number	Z	[1/h]	$Z = \frac{3600}{t_\Sigma}$														
(g)	Cycle factor	f_z	—	<table border="1"> <thead> <tr> <th>Z</th> <th>f_z</th> </tr> </thead> <tbody> <tr> <td>$Z \leq 1000$</td> <td>1.00</td> </tr> <tr> <td>$1000 < Z \leq 1500$</td> <td>1.25</td> </tr> <tr> <td>$1500 < Z \leq 2500$</td> <td>1.50</td> </tr> <tr> <td>$2500 < Z \leq 4000$</td> <td>1.75</td> </tr> <tr> <td>$4000 < Z \leq 6000$</td> <td>2.00</td> </tr> <tr> <td>$Z > 6000$</td> <td>contact us</td> </tr> </tbody> </table>	Z	f_z	$Z \leq 1000$	1.00	$1000 < Z \leq 1500$	1.25	$1500 < Z \leq 2500$	1.50	$2500 < Z \leq 4000$	1.75	$4000 < Z \leq 6000$	2.00	$Z > 6000$	contact us
Z	f_z																	
$Z \leq 1000$	1.00																	
$1000 < Z \leq 1500$	1.25																	
$1500 < Z \leq 2500$	1.50																	
$2500 < Z \leq 4000$	1.75																	
$4000 < Z \leq 6000$	2.00																	
$Z > 6000$	contact us																	
(h)	Temperature factor	f_T	—	<p>If $T \leq 30^\circ\text{C} \Rightarrow f_T = 1$</p> <p>If $T > 30^\circ\text{C} \Rightarrow f_T = 1 + \frac{T - 30}{100}$</p>														
(i)	Maximum input torque	$M_{1\text{ PEAK}}$	[Nm]	<p>a) maximum possible application torque</p> <p>b) limited motor torque by inverter</p> <p>c) maximum motor torque</p>														

K_n - speed constant					
i	LCK 050	LCK 070	LCK 090	LCK 120	LCK 155
6	2400	2400	2400	2000	1600
8	2400	2400	2400	2000	1600
10	2400	2400	2400	2000	1600
14	2400	2400	2400	2000	1600
20		2400	2400	2000	1600
24	2400	2400	2400	2000	1600
30	2400	2400	2400	2000	1600
50	2400	2400	2400	2000	1600
70	2400	2400	2400	2000	1600
80		2400	2400	2000	1600
90	2400				
100		2400	2400	2000	1600

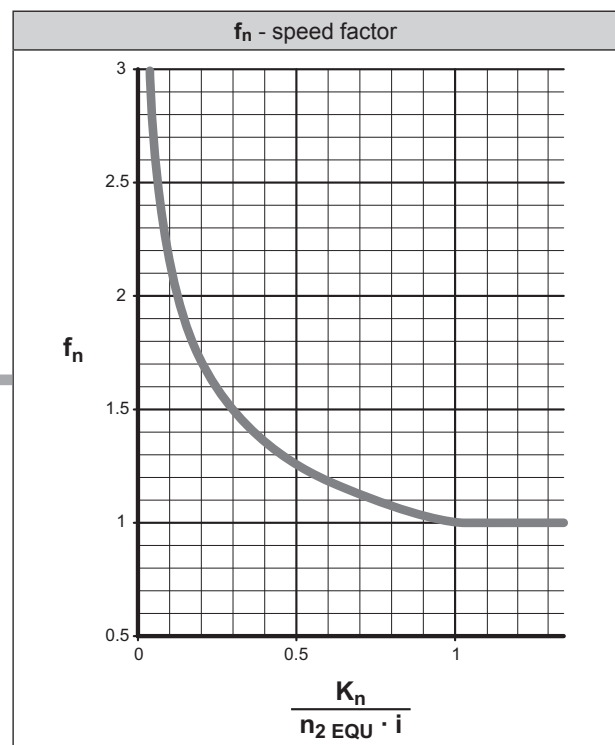

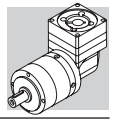

Load diagram

— M_2 : Output torque

Speed diagram

— n_2 : Output speed

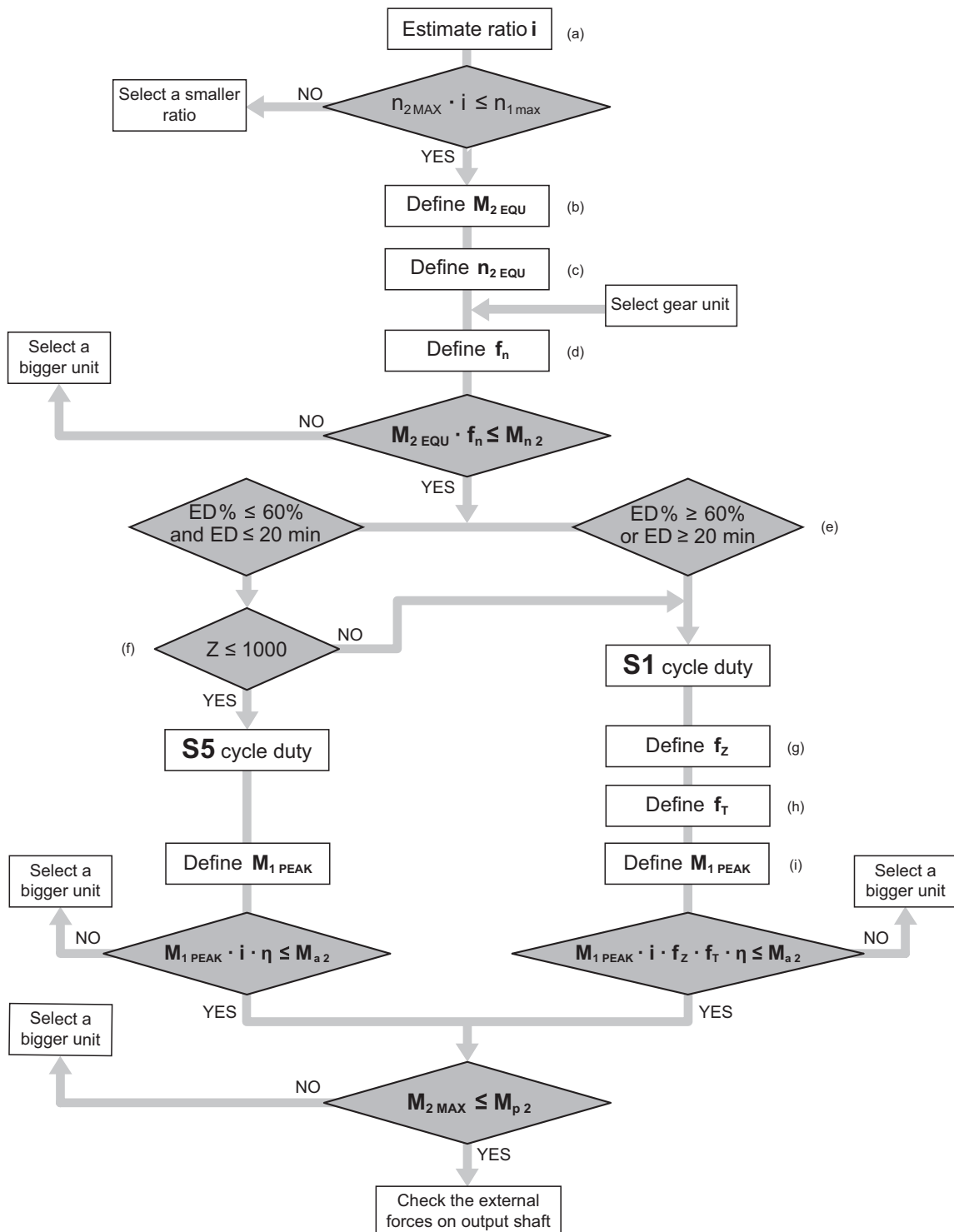
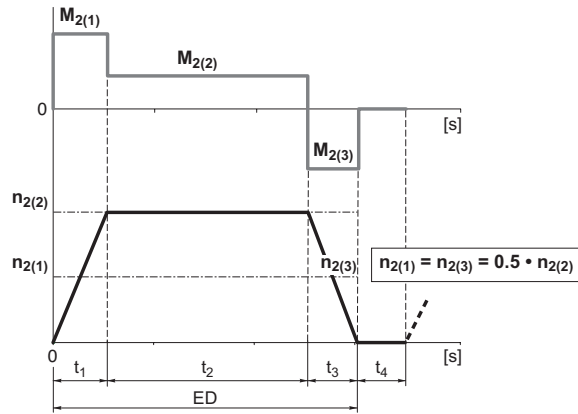

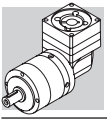

1.2 SERVICE LIFE OF BEARINGS

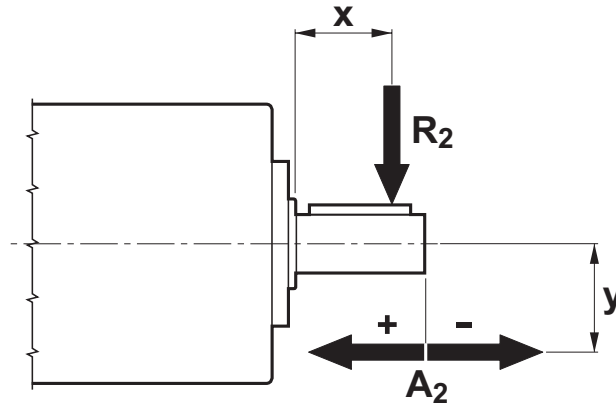

(a)	Maximum radial force applying on output shaft	$R_{2 \text{ MAX}}$	[N]	Please consider the specific conditions (e.g. belt drives under acceleration torque)
	Maximum axial force applying on output shaft	$A_{2 \text{ MAX}}$	[N]	
(b)	Maximum tilting moment	$M_{T2 \text{ MAX}}$	[Nm]	$M_{T2 \text{ MAX}} = \frac{R_{2 \text{ MAX}} \cdot (x + L_z) \pm A_{2 \text{ MAX}} \cdot y}{1000}$
(c)	Equivalent forces	$R_{2 \text{ EQU}}$	[N]	$R_{2 \text{ EQU}} = \sqrt[3]{\frac{n_{2(1)} \cdot t_1 \cdot R_{2(1)} ^3 + \dots + n_{2(n)} \cdot t_n \cdot R_{2(n)} ^3}{n_{2(1)} \cdot t_1 + \dots + n_{2(n)} \cdot t_n}}$
		$A_{2 \text{ EQU}}$	[N]	$A_{2 \text{ EQU}} = \sqrt[3]{\frac{n_{2(1)} \cdot t_1 \cdot A_{2(1)} ^3 + \dots + n_{2(n)} \cdot t_n \cdot A_{2(n)} ^3}{n_{2(1)} \cdot t_1 + \dots + n_{2(n)} \cdot t_n}}$
(d)	Equivalent tilting moment	$M_{T2 \text{ EQU}}$	[Nm]	$M_{T2 \text{ EQU}} = \frac{R_{2 \text{ EQU}} \cdot (x + L_z) + A_{2 \text{ EQU}} \cdot y}{1000}$
(e)	Equivalent output speed	$n_{2 \text{ EQU}}$	[min ⁻¹]	$n_{2 \text{ EQU}} = \frac{n_{2(1)} \cdot t_1 + n_{2(2)} \cdot t_2 + \dots + n_{2(n)} \cdot t_n}{t_1 + t_2 + \dots + t_n}$
(f)	Bearings' basic rating life	L_{10h}	[h]	$L_{10h} = \frac{16666}{n_{2 \text{ EQU}}} \cdot \left(\frac{C_B}{M_{T2 \text{ EQU}}} \right)^p$

		LCK 050	LCK 070	LCK 090	LCK 120	LCK 155
Lz	[mm]	22	28	30	39	46
M_{T2 max}	[Nm]	15	54	105	238	522
C_B	[Nm]	106	280	298	813	1588
p	—	3	3	3	3	3

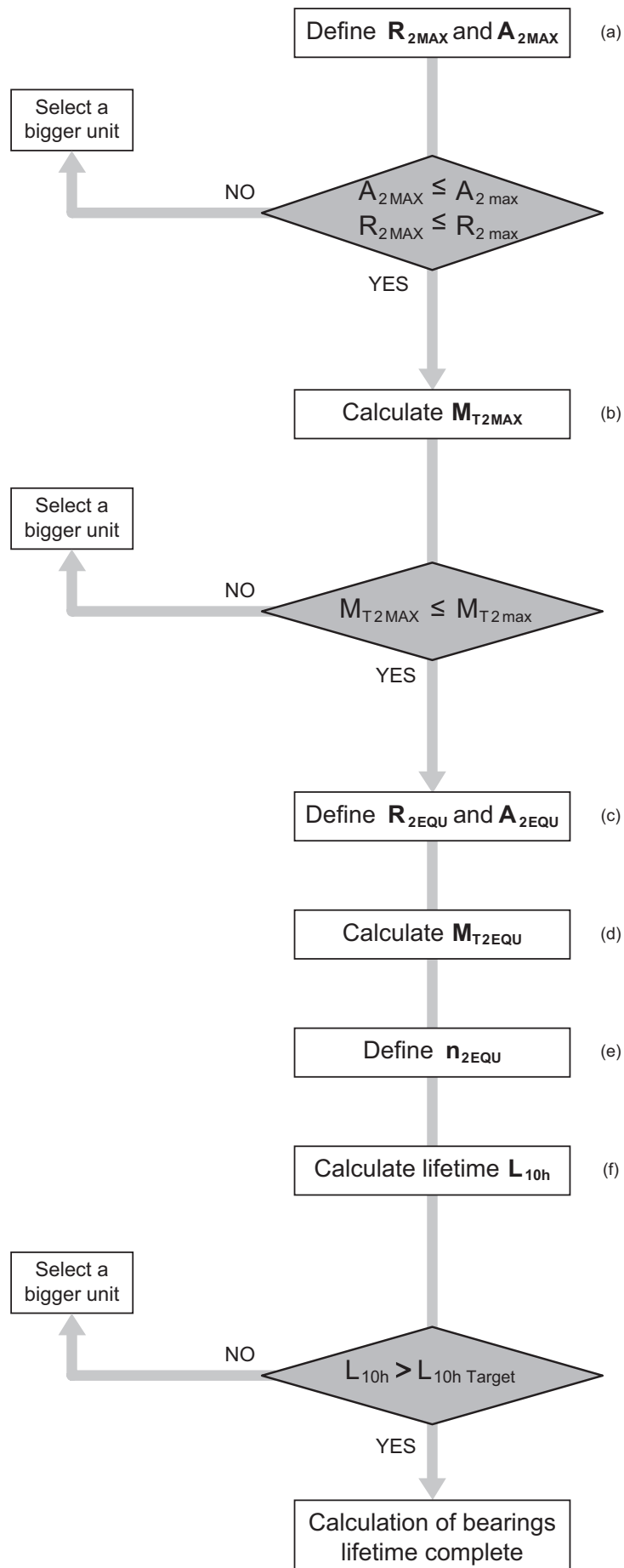
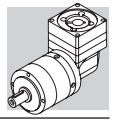

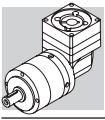

2 FEATURES OF LCK SERIES

Gear units of series LCK replicate in the right angle layout the brilliant features that are already typical of the in-line products of the LC series, with the additional benefit of a facilitated installation in tight spaces.

- Available in one only backlash option, corresponding to following values:
 double reduction gearheads: $\varphi_S = 6'$
 triple reduction gearheads: $\varphi_S = 8'$
- Degree of protection IP64
- Oil seals from Viton® compound as standard
- Max. noise level $L_P \leq 70 \text{ dB(A)} @ n_1 = 3000 \text{ min}^{-1}$
- Wide range of adapter flanges matching the most popular brands of motors
- Units are factory filled with synthetic grease to NLGI consistency class 00, suitable for installation in any mounting position and at ambient temperature within the range $0^\circ\text{C} \dots 40^\circ\text{C}$.
 In the absence of contamination the lubricant does not require periodical changes.

[i]	Distribution of nominal torque M_{n2} [Nm]											
	6	8	10	14	20	24	30	50	70	80	90	100
LCK 050	10	12	12	12	-	12	12	12	12	-	12	-
LCK 070	18	25	25	25	18	25	25	25	25	25	-	25
LCK 090	37	43	43	43	37	43	43	43	43	43	-	43
LCK 120	95	110	110	110	95	110	110	110	110	110	-	110
LCK 155	250	300	300	300	230	300	300	300	300	300	-	300

■ triple reduction gearheads

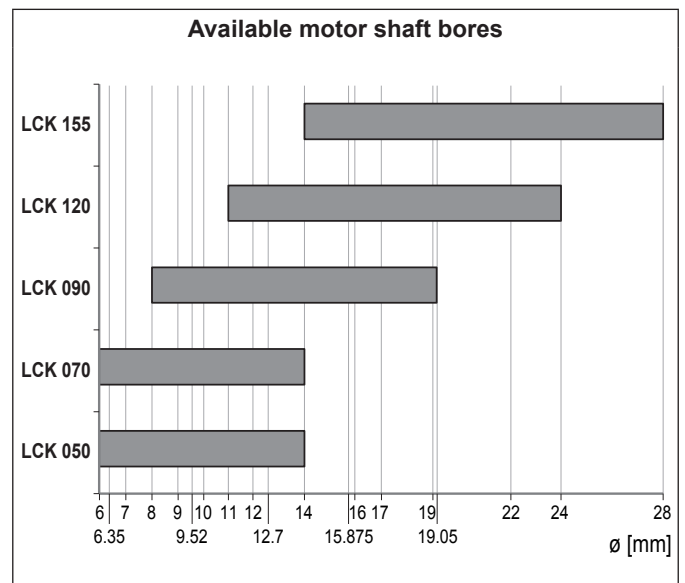
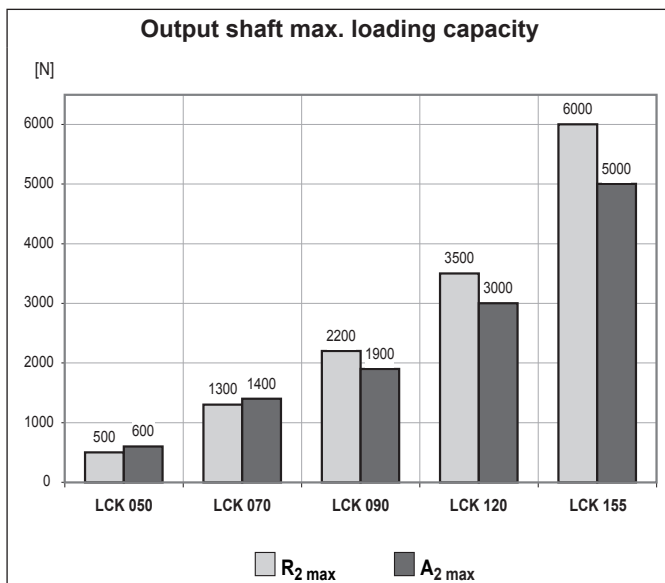

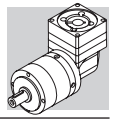

3 ORDERING CODE

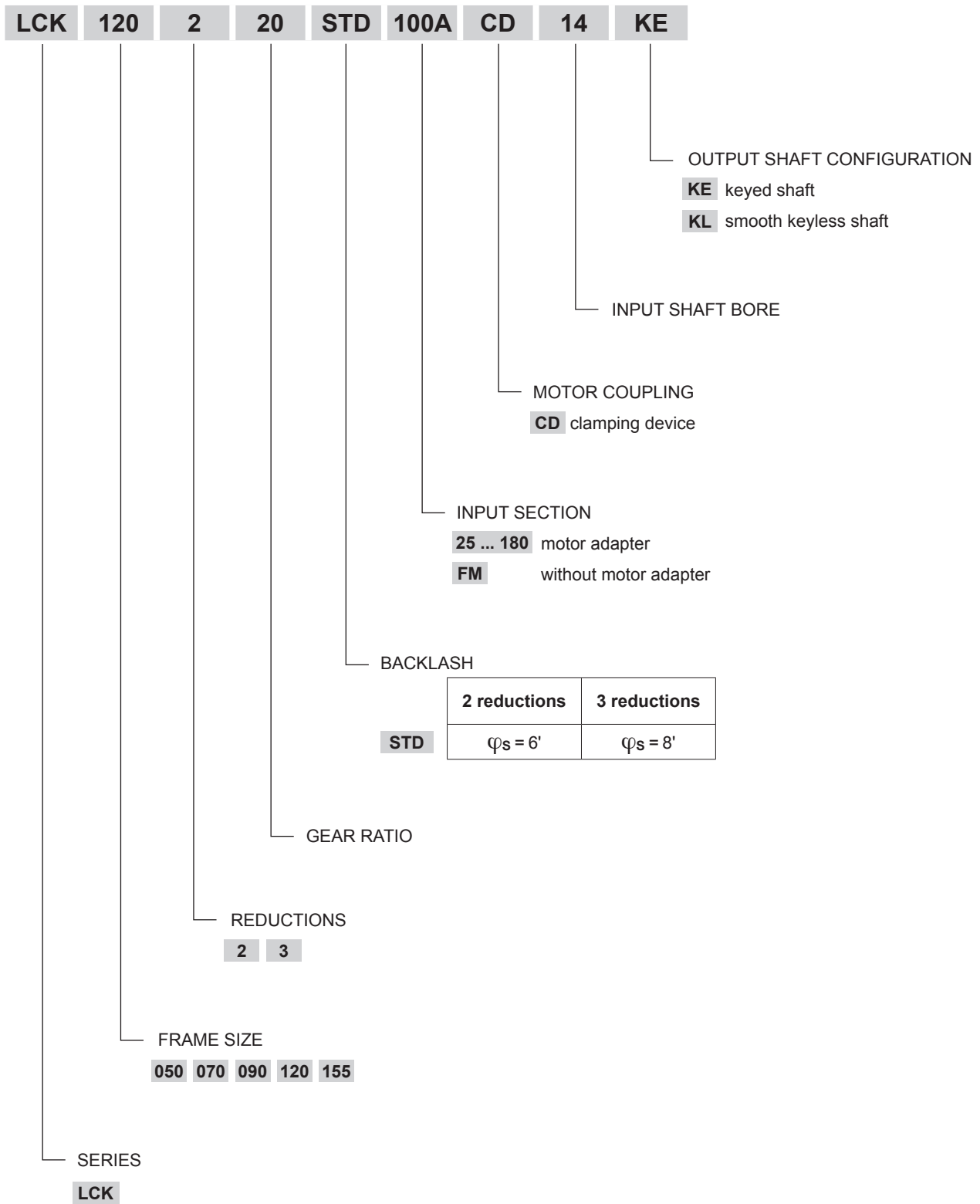

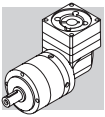

LCK 050

4 DIMENSIONS AND TECHNICAL SPECIFICATIONS

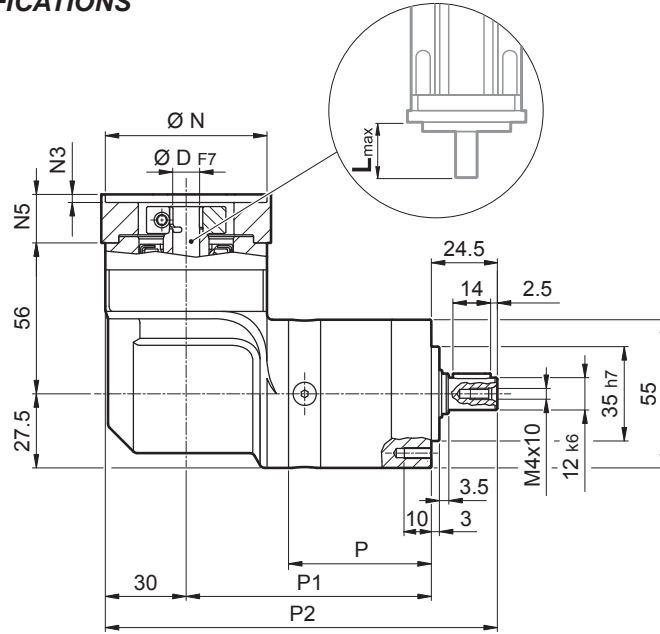
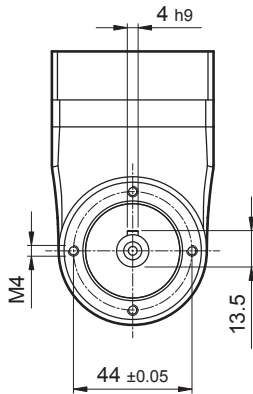

	P	P1	P2	Kg
LCK 050 2	53	91	145.5	1.6
LCK 050 3	66.8	104.8	159.3	1.8

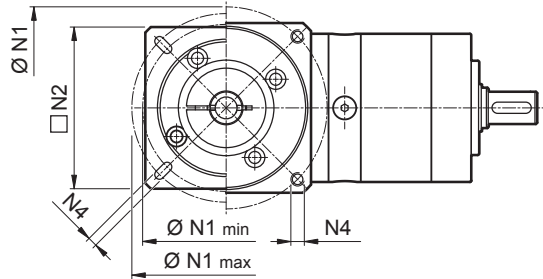

											N	N1		N2	N3	N4	N5	L _{max}
	6	6.35	7	8	9	9.52	-	-	-	-		min	max					
25AH	6	6.35	7	8	9	9.52	-	-	-	-	25	39	56					
26AH	6	6.35	7	8	9	9.52	-	-	-	-	26	39	56					
28AH	6	6.35	7	8	9	9.52	-	-	-	-	28	39	56					
30AH	6	6.35	7	8	9	9.52	-	-	-	-	30	39	56					
32AH	6	6.35	7	8	9	9.52	-	-	-	-	32	39	56	65	3.5	4.5	25	25
34AH	6	6.35	7	8	9	9.52	-	-	-	-	34	40	56					
36AH	6	6.35	7	8	9	9.52	-	-	-	-	36	42	56					
39AH	6	6.35	7	8	9	9.52	-	-	-	-	39	45	56					
40AH	6	6.35	7	8	9	9.52	-	-	-	-	40	46	56					
38B	6	6.35	7	8	9	9.52	10	11	12	12.7	-	38.1	66.6	60	3	M4x10	18	25
40B	6	6.35	7	8	9	9.52	10	11	12	12.7	-	40	63	60	3	M4x10	18	25
50A	6	6.35	7	8	9	9.52	10	11	12	12.7	-	50	60	60	3	M4x10	18	25
50B	6	6.35	7	8	9	9.52	10	11	12	12.7	14	50	65	60	3	M5x12	23	30
50BH	6	6.35	7	8	9	9.52	10	11	12	12.7	14	50	65	65	3	5.5	25	32
50C	6	6.35	7	8	9	9.52	10	11	12	12.7	14	50	70	60	3	M4x10	23	30
55MH	6	6.35	7	8	9	9.52	10	11	12	12.7	-	55	80	65	2	5.5	16	23
60A	6	6.35	7	8	9	9.52	10	11	12	12.7	-	60	75	63	3	M5x12	18	25
60A1	6	6.35	7	8	9	9.52	10	11	12	12.7	14	60	75	63	3	M5x12	23	30
60B	6	6.35	7	8	9	9.52	10	11	12	12.7	14	60	85	75	3	M5x12	23	30
60C	6	6.35	7	8	9	9.52	10	11	12	12.7	14	60	90	75	3	M5x12	23	30
70A	6	6.35	7	8	9	9.52	10	11	12	12.7	14	70	85	75	3	M6x15	23	30
70B	6	6.35	7	8	9	9.52	10	11	12	12.7	14	70	90	75	3	M5x12	23	30
73A	6	6.35	7	8	9	9.52	10	11	12	12.7	14	73	98.4	85	3	M5x12	25	32
80A	6	6.35	7	8	9	9.52	10	11	12	12.7	14	80	100	85	3	M6x15	23	30

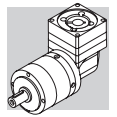

FM

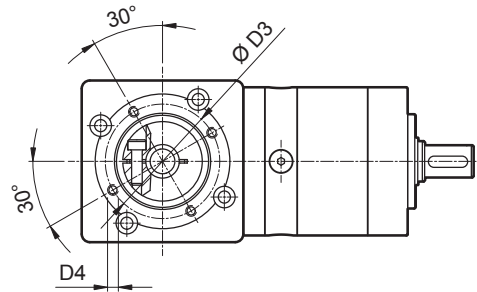
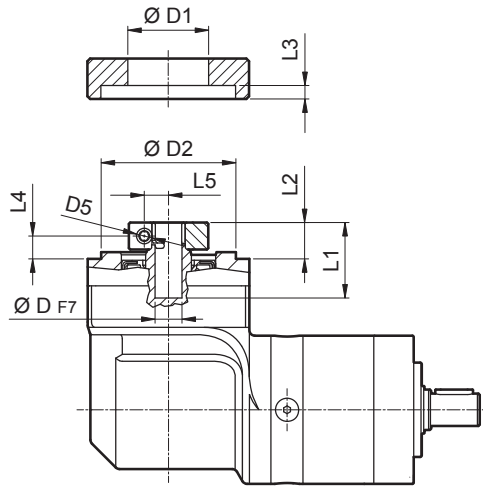
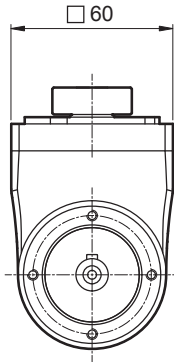

D	D			D1	D2	D3	D4	D5	L1	L2	L3	L4	L5
	6.35	7	10										
6	6.35	7	10	32.5	50	42.5	M4x8	M4	28	13.5	3	8.5	8
8	9	9.52	10	32.5	50	42.5	M4x8	M4	28	13.5	3	8.5	9
11	12	12.7		35.5	50	42.5	M4x8	M4	23	13.5	3	8.5	11
14				35.5	50	42.5	M4x8	M4	25	15.5	3	8.9	11.5

i	M _{n 2} [Nm]	M _{a 2} [Nm]	M _{p 2} [Nm]	n _{1 max} [min ⁻¹]	φ _s [arcmin]	C _t [$\frac{Nm}{arcmin}$]	R _{2 max} [N]	A _{2 max} [N]	η %	J _G [kgcm ²]	
										D	
LCK 050 2_6	10	16	28	5000	6'	0.9	500	600	94	0.23	0.25
LCK 050 2_8	12	20	30	5000	6'	0.9	500	600	94	0.23	0.24
LCK 050 2_10	12	20	30	5000	6'	0.9	500	600	94	0.23	0.24
LCK 050 2_14	12	20	30	5000	6'	0.9	500	600	94	0.23	0.24
LCK 050 3_24	12	20	30	5000	8'	0.7	500	600	91	0.23	0.25
LCK 050 3_30	12	20	30	5000	8'	0.7	500	600	91	0.23	0.25
LCK 050 3_50	12	20	30	5000	8'	0.7	500	600	91	0.23	0.24
LCK 050 3_70	12	20	30	5000	8'	0.7	500	600	91	0.23	0.24
LCK 050 3_90	12	20	30	5000	8'	0.7	500	600	91	0.22	0.24

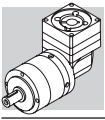

LCK 070

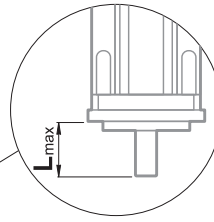
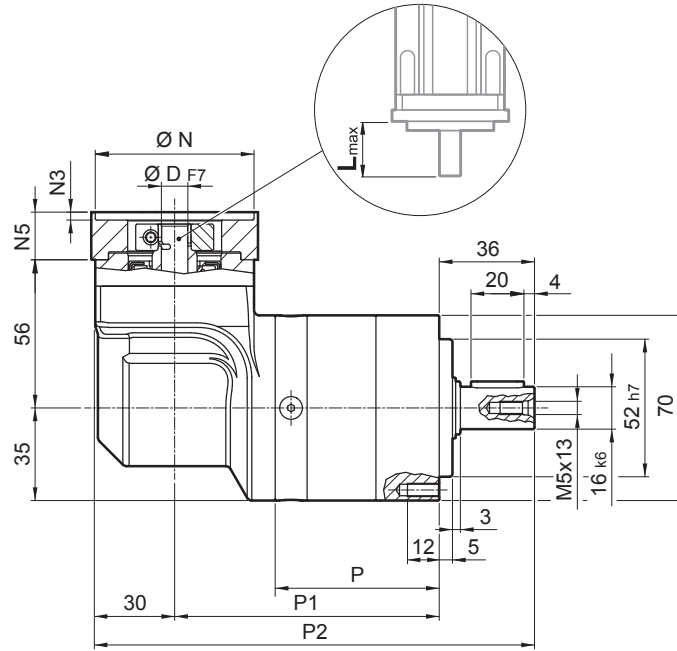
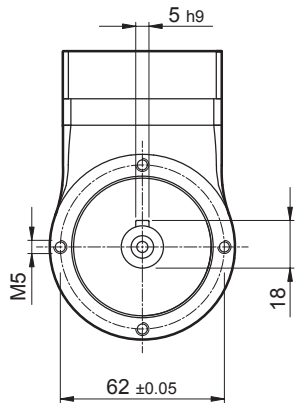

	P	P1	P2	Kg
LCK 070 2	62	100	166	2.7
LCK 070 3	78.7	116.7	182.7	3.0

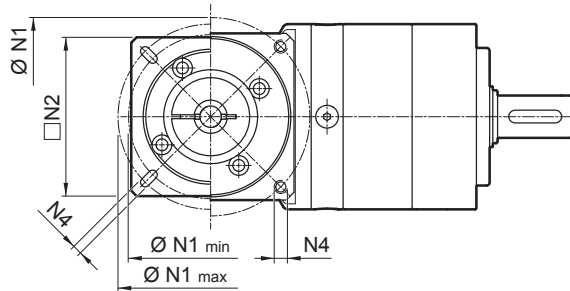

											N	N1		N2	N3	N4	N5	L _{max}
	D											min	max					
25AH	6	6.35	7	8	9	9.52	-	-	-	-	25	39	56					
26AH	6	6.35	7	8	9	9.52	-	-	-	-	26	39	56					
28AH	6	6.35	7	8	9	9.52	-	-	-	-	28	39	56					
30AH	6	6.35	7	8	9	9.52	-	-	-	-	30	39	56					
32AH	6	6.35	7	8	9	9.52	-	-	-	-	32	39	56	65	3.5	4.5	25	25
34AH	6	6.35	7	8	9	9.52	-	-	-	-	34	40	56					
36AH	6	6.35	7	8	9	9.52	-	-	-	-	36	42	56					
39AH	6	6.35	7	8	9	9.52	-	-	-	-	39	45	56					
40AH	6	6.35	7	8	9	9.52	-	-	-	-	40	46	56					
38B	6	6.35	7	8	9	9.52	10	11	12	12.7	-	38.1	66.6	60	3	M4x10	18	25
40B	6	6.35	7	8	9	9.52	10	11	12	12.7	-	40	63	60	3	M4x10	18	25
50A	6	6.35	7	8	9	9.52	10	11	12	12.7	-	50	60	60	3	M4x10	18	25
50B	6	6.35	7	8	9	9.52	10	11	12	12.7	14	50	65	60	3	M5x12	23	30
50BH	6	6.35	7	8	9	9.52	10	11	12	12.7	14	50	65	65	3	5.5	25	32
50C	6	6.35	7	8	9	9.52	10	11	12	12.7	14	50	70	60	3	M4x10	23	30
55MH	6	6.35	7	8	9	9.52	10	11	12	12.7	-	55	80	65	2	5.5	16	23
60A	6	6.35	7	8	9	9.52	10	11	12	12.7	-	60	75	63	3	M5x12	18	25
60A1	6	6.35	7	8	9	9.52	10	11	12	12.7	14	60	75	63	3	M5x12	23	30
60B	6	6.35	7	8	9	9.52	10	11	12	12.7	14	60	85	75	3	M5x12	23	30
60C	6	6.35	7	8	9	9.52	10	11	12	12.7	14	60	90	75	3	M5x12	23	30
70A	6	6.35	7	8	9	9.52	10	11	12	12.7	14	70	85	75	3	M6x15	23	30
70B	6	6.35	7	8	9	9.52	10	11	12	12.7	14	70	90	75	3	M5x12	23	30
73A	6	6.35	7	8	9	9.52	10	11	12	12.7	14	73	98.4	85	3	M5x12	25	32
80A	6	6.35	7	8	9	9.52	10	11	12	12.7	14	80	100	85	3	M6x15	23	30

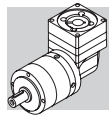

FM

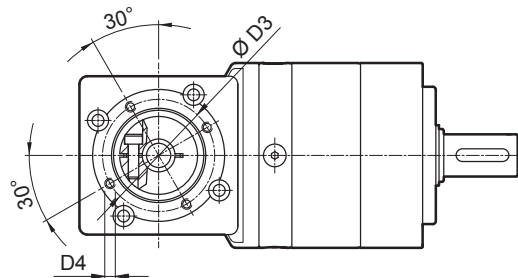
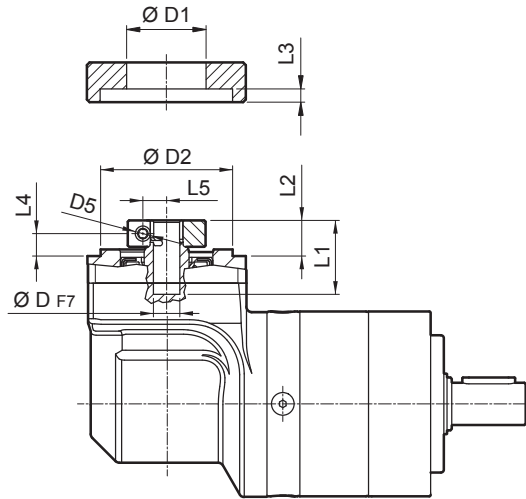
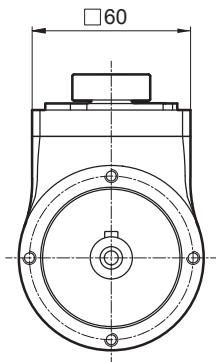

D	D			D1	D2	D3	D4	D5	L1	L2	L3	L4	L5
	6.35	7	10										
6	6.35	7	10	32.5	50	42.5	M4x8	M4	28	13.5	3	8.5	8
8	9	9.52	10	32.5	50	42.5	M4x8	M4	28	13.5	3	8.5	9
11	12	12.7		35.5	50	42.5	M4x8	M4	23	13.5	3	8.5	11
14				35.5	50	42.5	M4x8	M4	25	15.5	3	8.9	11.5

i	M _{n 2} [Nm]	M _{a 2} [Nm]	M _{p 2} [Nm]	n _{1 max} [min ⁻¹]	φ _s [arcmin]	C _t [$\frac{Nm}{arcmin}$]	R _{2 max} [N]	A _{2 max} [N]	η %	J _G [kgcm ²]	
										D	
LCK 070 2_6	18	30	45	5000	6'	2.8	1300	1400	94	0.25	0.26
LCK 070 2_8	25	35	60	5000	6'	2.8	1300	1400	94	0.24	0.25
LCK 070 2_10	25	35	70	5000	6'	2.8	1300	1400	94	0.23	0.25
LCK 070 2_14	25	35	70	5000	6'	2.8	1300	1400	94	0.23	0.24
LCK 070 2_20	18	30	60	5000	6'	2.8	1300	1400	94	0.23	0.24
LCK 070 3_24	25	35	70	5000	8'	2.5	1300	1400	91	0.24	0.26
LCK 070 3_30	25	35	70	5000	8'	2.5	1300	1400	91	0.24	0.26
LCK 070 3_50	25	35	70	5000	8'	2.5	1300	1400	91	0.23	0.24
LCK 070 3_70	25	35	70	5000	8'	2.5	1300	1400	91	0.23	0.24
LCK 070 3_80	25	35	70	5000	8'	2.5	1300	1400	91	0.23	0.24
LCK 070 3_100	25	35	70	5000	8'	2.5	1300	1400	91	0.23	0.24

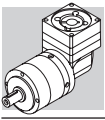

LCK 090

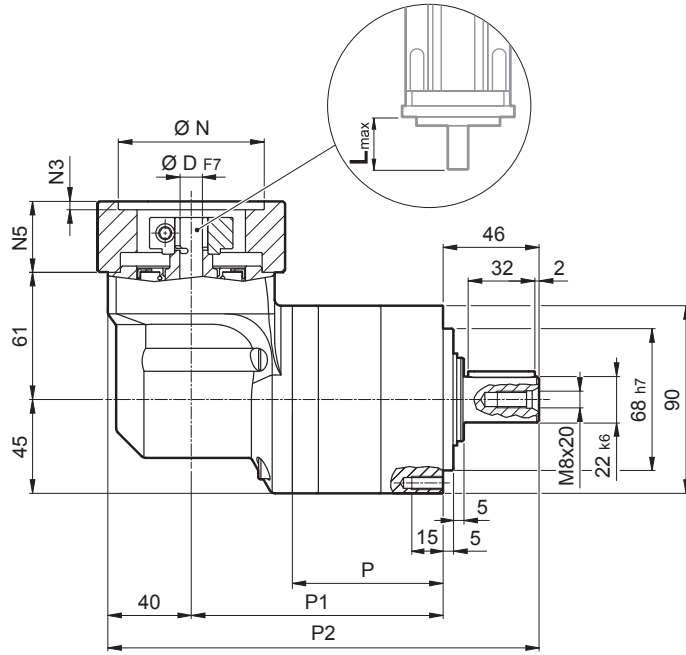
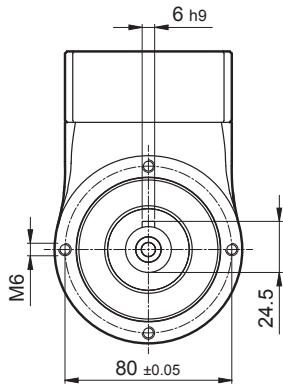

	P	P1	P2	Kg
LCK 090 2	72.3	120.8	206.8	5.2
LCK 090 3	98.8	147.3	233.3	6.3

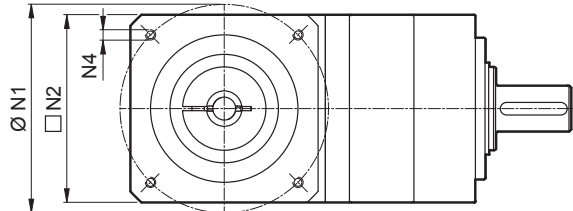

												N	N1	N2	N3	N4	N5	L _{max}	
40B1	8	9	9.52	11	12	12.7	14	-	-	-	-	-	40	63	80	4	M4x10	34	40
45A	8	9	9.52	11	12	12.7	-	-	-	-	-	-	45	63	80	4	M4x10	34	40
50B1	8	9	9.52	11	12	12.7	14	-	-	-	-	-	50	65	80	4	M5x16	34	40
50BH1	8	9	9.52	11	12	12.7	14	-	-	-	-	-	50	65	80	4	5.5	34	40
50C1	8	9	9.52	11	12	12.7	14	-	-	-	-	-	50	70	80	4	M4x10	34	40
50D	8	9	9.52	11	12	12.7	14	-	-	-	-	-	50	95	80	4	M6x10	34	40
55A	8	9	9.52	11	12	12.7	14	15.875	16	17	19	19.05	55.5	125.7	105	4	M6x16	34	40
60A2	8	9	9.52	11	12	12.7	14	-	-	-	-	-	60	75	80	4	M5x16	34	40
60AH2	8	9	9.52	11	12	12.7	14	-	-	-	-	-	60	75	90	4	5.5	34	40
60B1	8	9	9.52	11	12	12.7	14	15.875	16	-	-	-	60	85	80	4	M5x16	34	40
60C1	8	9	9.52	11	12	12.7	14	15.875	16	-	-	-	60	90	80	4	M5x16	34	40
70A1	8	9	9.52	11	12	12.7	14	15.875	16	17	19	19.05	70	85	80	4	M6x20	34	40
70AH1	8	9	9.52	11	12	12.7	14	15.875	16	17	19	19.05	70	85	90	4	6.5	34	40
70B1	8	9	9.52	11	12	12.7	14	15.875	16	17	19	19.05	70	90	80	4	M5x16	34	40
73A1	8	9	9.52	11	12	12.7	14	-	-	-	-	-	73	98.4	85	4	M5x16	34	40
80A1	8	9	9.52	11	12	12.7	14	15.875	16	17	19	19.05	80	100	90	4	M6x16	34	40
95A	8	9	9.52	11	12	12.7	14	15.875	16	17	19	19.05	95	115	100	4	M8x20	34	40
95B	8	9	9.52	11	12	12.7	14	15.875	16	17	19	19.05	95	130	115	4	M8x20	34	40
110A	8	9	9.52	11	12	12.7	14	15.875	16	17	19	19.05	110	130	115	4	M8x20	34	40
110B	8	9	9.52	11	12	12.7	14	15.875	16	17	19	19.05	110	145	120	6.5	M8x20	44	50
110B1	8	9	9.52	11	12	12.7	14	15.875	16	17	19	19.05	110	145	120	6.5	M8x20	54	60

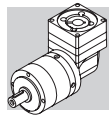

FM

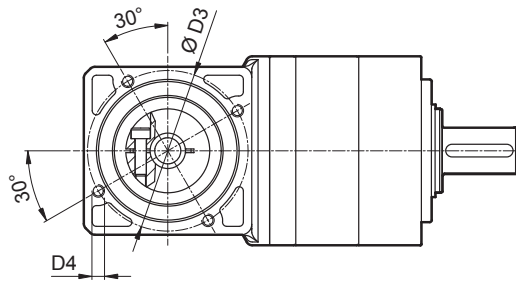
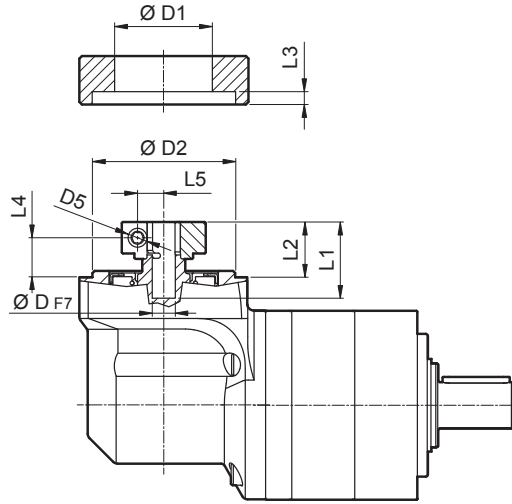
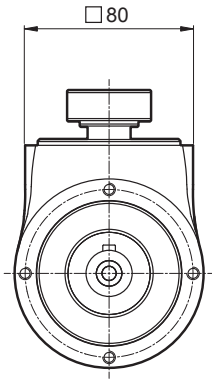

				D1	D2	D3	D4	D5	L1	L2	L3	L4	L5
8	9	9.52		38	68	76.5	M6x10	M6	36.3	26.3	9.5	18.8	10.5
11	12	12.7		43	68	76.5	M6x10	M6	36.3	26.3	9.5	18.8	12.5
14	15.875	16	17	48	68	76.5	M6x10	M6	36.3	26.3	9.5	18.8	14.5
19	19.05			51	68	76.5	M6x10	M6	36.3	26.3	9.5	18.8	16.5

	i	M _{n 2}	M _{a 2}	M _{p 2}	n _{1 max}	φ _s	C _t	R _{2 max}	A _{2 max}	η	J _G [kgcm ²]		
		[Nm]	[Nm]	[Nm]	[min ⁻¹]	[arcmin]	$\frac{Nm}{arcmin}$	[N]	[N]	%		8 ... 12.7	14 ... 19.05
LCK 090 2_6		37	63	90	5000	6'	6.1	2200	1900	94		0.85	1.03
LCK 090 2_8		43	80	120	5000	6'	6.1	2200	1900	94		0.79	0.98
LCK 090 2_10		43	80	150	5000	6'	6.1	2200	1900	94		0.77	0.96
LCK 090 2_14		43	80	160	5000	6'	6.1	2200	1900	94		0.75	0.94
LCK 090 2_20		37	70	150	5000	6'	6.1	2200	1900	94		0.74	0.93
LCK 090 3_24		43	80	160	5000	8'	5.9	2200	1900	91		0.81	1.00
LCK 090 3_30		43	80	160	5000	8'	5.9	2200	1900	91		0.81	1.00
LCK 090 3_50		43	80	160	5000	8'	5.9	2200	1900	91		0.76	0.94
LCK 090 3_70		43	80	160	5000	8'	5.9	2200	1900	91		0.74	0.93
LCK 090 3_80		43	80	160	5000	8'	5.9	2200	1900	91		0.74	0.93
LCK 090 3_100		43	80	160	5000	8'	5.9	2200	1900	91		0.74	0.93

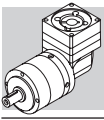

LCK 120

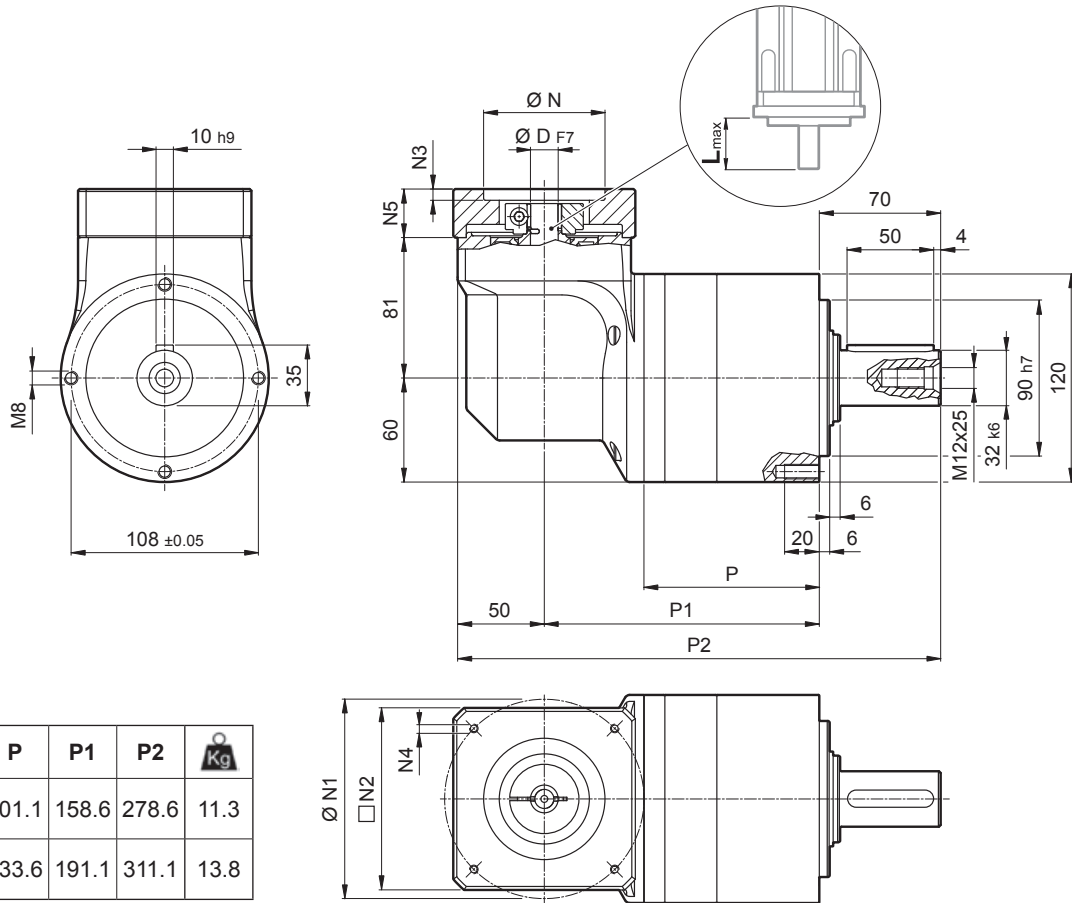

	P	P1	P2	Kg
LCK 120 2	101.1	158.6	278.6	11.3
LCK 120 3	133.6	191.1	311.1	13.8

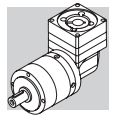

											N	N1	N2	N3	N4	N5	L _{max}
50D	11	12	12.7	14	15	15.875	16	19	-	-	50	95	100	5	M6x14	28	40
55A	11	12	12.7	14	15	15.875	16	19	-	-	55.5	125.7	105	5	M6x16	28	40
60A2	11	12	12.7	14	15	15.875	16	19	-	-	60	75	100	5	M5x14	28	40
60AH2	11	12	12.7	14	15	15.875	16	19	-	-	60	75	100	5	6.5	33	40
60B1	11	12	12.7	14	15	15.875	16	19	-	-	60	85	100	6.5	M5x14	28	40
70A1	11	12	12.7	14	15	15.875	16	19	-	-	70	85	100	5	M6x14	28	40
70AH1	11	12	12.7	14	15	15.875	16	19	-	-	70	85	100	5	6	33	40
70B1	11	12	12.7	14	15	15.875	16	19	-	-	70	90	100	5	M5x12	28	40
80A1	11	12	12.7	14	15	15.875	16	19	-	-	80	100	100	5	M6x16	28	40
80AH1	11	12	12.7	14	15	15.875	16	19	-	-	80	100	100	5	6.5	28	40
95A	11	12	12.7	14	15	15.875	16	19	-	-	95	115	100	5	M8x18	28	40
95A1	11	12	12.7	14	15	15.875	16	19	22	24	95	115	100	5	M8x18	38	50
95B	11	12	12.7	14	15	15.875	16	19	-	-	95	130	115	5	M8x18	28	40
110A	11	12	12.7	14	15	15.875	16	19	-	-	110	130	115	5	M8x18	28	40
110A1	11	12	12.7	14	15	15.875	16	19	22	24	110	130	115	6.5	M8x20	38	50
110B	11	12	12.7	14	15	15.875	16	19	22	24	110	145	120	6.5	M8x20	38	50
110B1	11	12	12.7	14	15	15.875	16	19	22	24	110	145	120	6.5	M8x20	48	60
130A	11	12	12.7	14	15	15.875	16	19	22	24	130	165	140	6.5	M10x20	38	50
130A1	11	12	12.7	14	15	15.875	16	19	22	24	130	165	140	6.5	M10x25	48	60

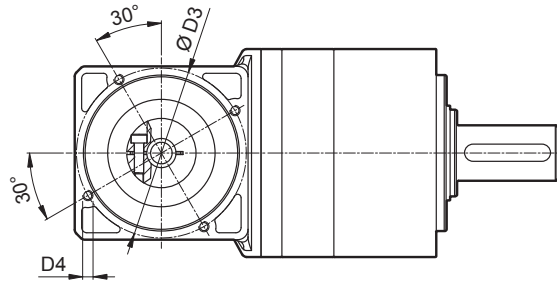
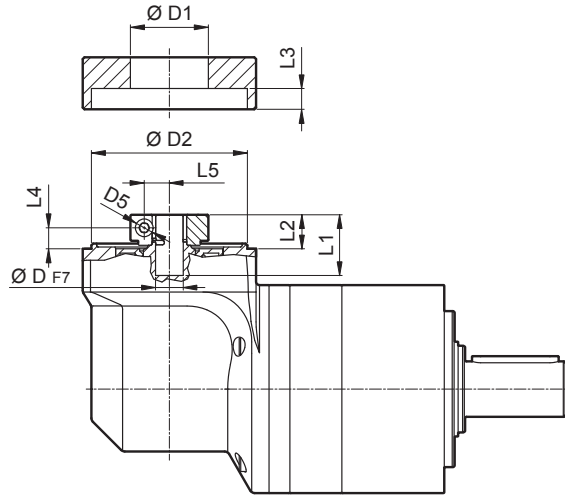
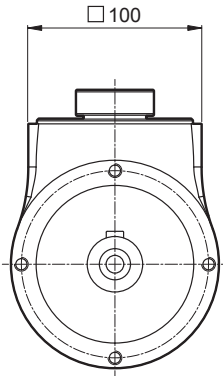

FM

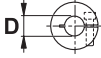

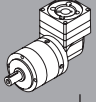

				D1	D2	D3	D4	D5	L1	L2	L3	L4	L5
11	12	12.7		43	90	98	M6x15	M6	35	19.5	7.6	12.1	12.5
14	15	15.875	16	48	90	98	M6x15	M6	35	19.5	7.6	12.1	14.5
19				51	90	98	M6x15	M6	35	19.5	7.6	12.1	16.5
22	24			56.5	90	98	M6x15	M6	37	21.5	7.6	12.1	19

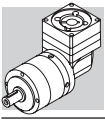
	i	M _{n 2} [Nm]	M _{a 2} [Nm]	M _{p 2} [Nm]	n _{1 max} [min ⁻¹]	ψ _s [arcmin]	C _t [$\frac{Nm}{arcmin}$]	R _{2 max} [N]	A _{2 max} [N]	η %	J _G [kgcm ²]		
												11 ... 12.7	14 ... 19
LCK 120 2_6		95	156	225	4500	6'	19.9	3500	3000	94	1.74	1.82	2.01
LCK 120 2_8		110	190	300	4500	6'	19.9	3500	3000	94	1.52	1.60	1.79
LCK 120 2_10		110	190	360	4500	6'	19.9	3500	3000	94	1.44	1.52	1.71
LCK 120 2_14		110	190	360	4500	6'	19.9	3500	3000	94	1.37	1.45	1.63
LCK 120 2_20		95	160	300	4500	6'	19.9	3500	3000	94	1.32	1.40	1.59
LCK 120 3_24		110	190	360	4500	8'	20.4	3500	3000	91	1.64	1.72	1.90
LCK 120 3_30		110	190	360	4500	8'	20.4	3500	3000	91	1.63	1.71	1.89
LCK 120 3_50		110	190	360	4500	8'	20.4	3500	3000	91	1.40	1.48	1.67
LCK 120 3_70		110	190	360	4500	8'	20.4	3500	3000	91	1.34	1.42	1.61
LCK 120 3_80		110	190	360	4500	8'	20.4	3500	3000	91	1.31	1.39	1.58
LCK 120 3_100		110	190	360	4500	8'	20.4	3500	3000	91	1.31	1.39	1.58

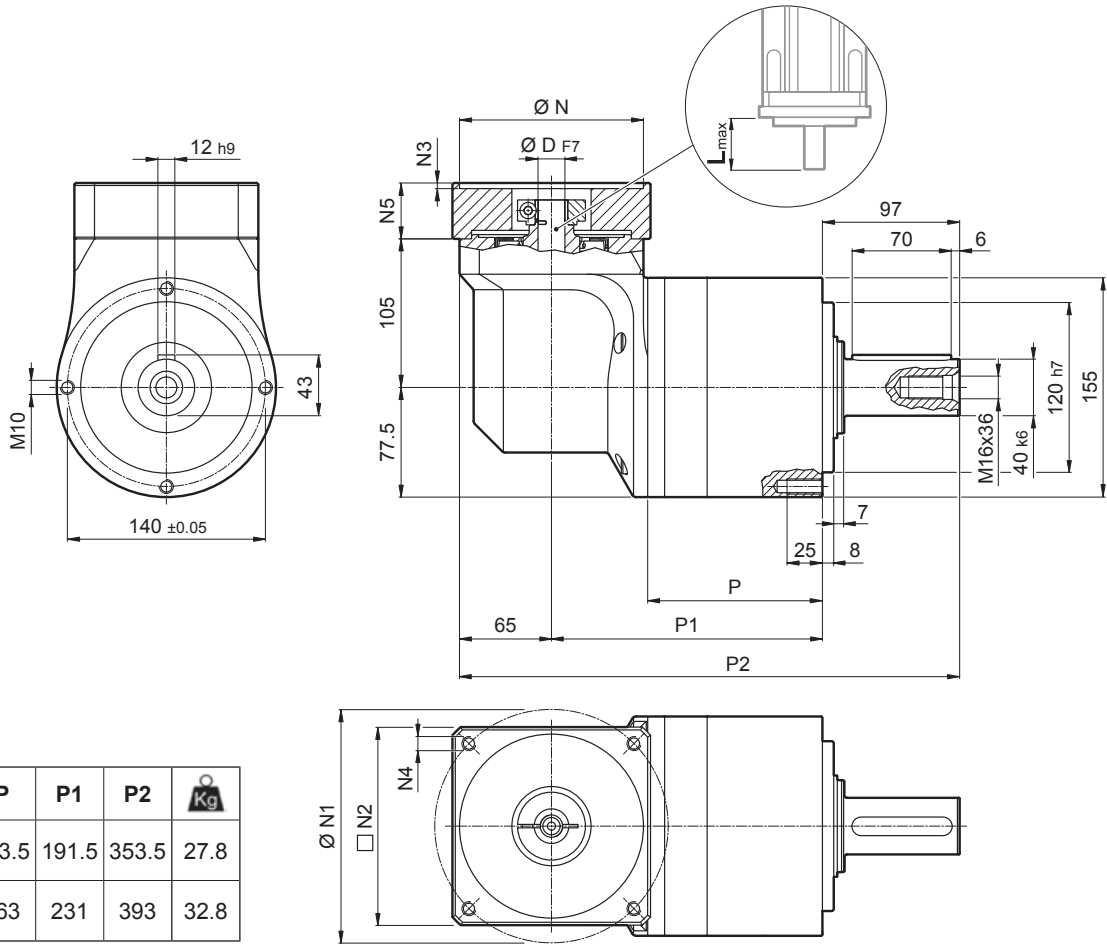

LCK 155

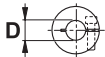

	P	P1	P2	
LCK 155 2	123.5	191.5	353.5	27.8
LCK 155 3	163	231	393	32.8

								N	N1	N2	N3	N4	N5	L _{max}
55A1	14	15.875	16	19	-	-	-	55.5	125.7	130	4	M6x15	39.5	50
80A2	14	15.875	16	19	-	-	-	80	100	130	4	M6x15	39.5	50
95A1	14	15.875	16	19	22	24	-	95	115	130	4	M8x20	39.5	50
110A1	14	15.875	16	19	22	24	-	110	130	130	4	M8x20	39.5	50
110B1	14	15.875	16	19	22	24	-	110	145	130	6.5	M8x20	49.5	60
114A	14	15.875	16	19	22	24	28	114.3	200	170	5.5	M12x25	69.5	80
130A	14	15.875	16	19	22	24	-	130	165	140	4	M10x20	39.5	50
130A1	14	15.875	16	19	22	24	28	130	165	140	4	M10x20	49.5	60
180A	14	15.875	16	19	22	24	28	180	215	190	5.5	M14x25	49.5	60
180A1	14	15.875	16	19	22	24	28	180	215	190	5.5	M14x25	69.5	80

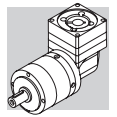

FM

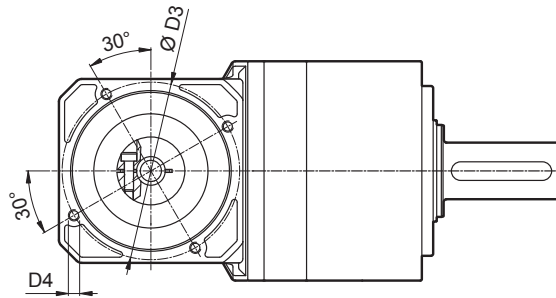
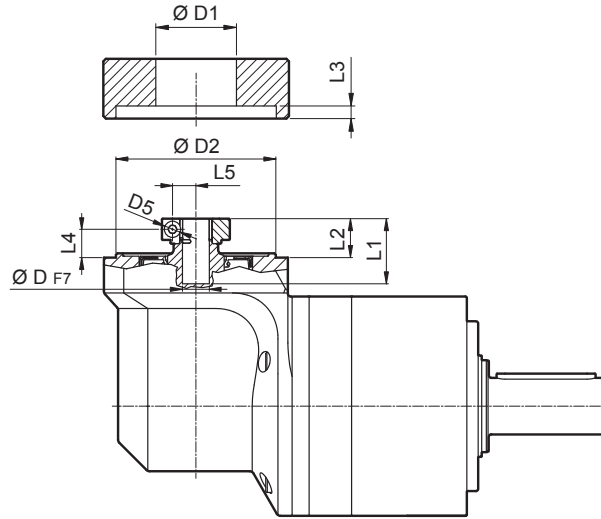
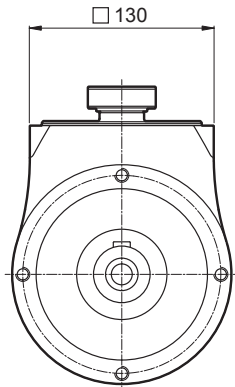

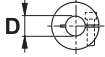
			D1	D2	D3	D4	D5	L1	L2	L3	L4	L5
14	15.875	16	48	113	125.5	M8x15	M6	46	27.5	6	20	14.5
19			51	113	125.5	M8x15	M6	46	27.5	6	20	16.5
22	24		56.5	113	125.5	M8x15	M6	47.5	29	6	20	19
28			67	113	125.5	M8x15	M8	47.5	29	6	20	22.5

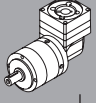
	i	M _{n 2}	M _{a 2}	M _{p 2}	n _{1 max}	ψ _s	C _t	R _{2 max}	A _{2 max}	η	J _G [kgcm ²]		
		[Nm]	[Nm]	[Nm]	[min ⁻¹]	[arcmin]	$\frac{Nm}{arcmin}$	[N]	[N]		14 ... 19	22 ; 24	28
LCK 155 2_6		250	360	510	4500	6'	40.7	6000	5000	94	7.94	8.13	8.53
LCK 155 2_8		300	450	680	4500	6'	40.7	6000	5000	94	7.11	7.30	7.70
LCK 155 2_10		300	450	850	4500	6'	40.7	6000	5000	94	6.78	6.96	7.36
LCK 155 2_14		300	450	900	4500	6'	40.7	6000	5000	94	6.48	6.67	7.07
LCK 155 2_20		230	350	750	4500	6'	40.7	6000	5000	94	6.31	6.49	6.90
LCK 155 3_24		300	450	900	4500	8'	37.4	6000	5000	91	7.18	7.37	7.77
LCK 155 3_30		300	450	900	4500	8'	37.4	6000	5000	91	7.14	7.33	7.73
LCK 155 3_50		300	450	900	4500	8'	37.4	6000	5000	91	6.49	6.68	7.08
LCK 155 3_70		300	450	900	4500	8'	37.4	6000	5000	91	6.33	6.52	6.92
LCK 155 3_80		300	450	700	4500	8'	37.4	6000	5000	91	6.25	6.43	6.83
LCK 155 3_100		300	450	900	4500	8'	37.4	6000	5000	91	6.24	6.43	6.83

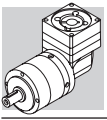

INDEX OF REVISIONS (R)

R1	
	Description
4	Sect 1.1 "Selecting the gear unit" - new selection procedure
9	Sect 3 "Ordering code" - ordering code for keyed output shaft (KE) newly added
10 ... 19	Sect. 4 "Dimensions and technical specifications" - tolerance (h9) for the key of the output shaft newly added - updated weight of gear units - values for torsional stiffness (C_t) newly added - updated dimensions

110120

This publication supersedes and replaces any previous edition and revision. We reserve the right to implement modifications without notice.
This catalogue cannot be reproduced, even partially, without prior consent.



Bonfiglioli has been designing and developing innovative and reliable power transmission and control solutions for industry, mobile machinery and renewable energy applications since 1956.