

TORQUE LIMITER

SERIES 320



AUTOGARD SERIES 320 TORQUE LIMITER

Quality and Autogard are synonymous with overload protection. The company's reputation for high quality products is derived from over 35 years of design innovation and production. Autogard products are manufactured to meet ISO 9001 using the latest machine tools and high quality materials.

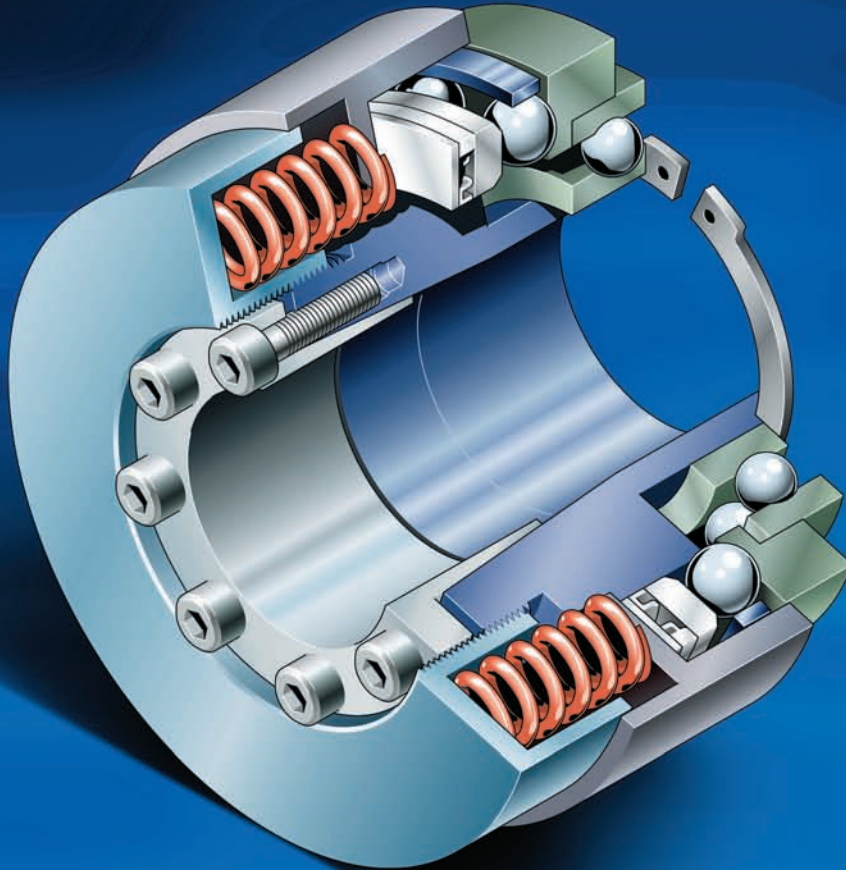

The Series 320 Torque Limiter Clutch has been designed to meet the emerging need for an economical, compact and reliable safety clutch. The optimised design provides a robust, backlash free clutch which will protect equipment from the damaging effects caused by overloading a drive train.

In the event of an overload, the drive balls are designed to roll out of their respective seats producing an axial movement in the cover plate. A proximity sensor or limit switch can be used to detect this movement, sending a signal to master control or a PLC.

Re-engagement is automatic once the overload is removed. The Series 320 can be provided in a timed (synchronised) or un-timed (rapid reset) versions.

The Autogard Series 320 is designed to meet the most exacting needs of modern machinery.

Features and Benefits

- Accurate torque limitation prevents costly downtime caused by overloads.
- The compact Design reduces weight and inertia on the equipment.
- The standard design can accommodate larger torque ranges than many other models currently available.
- Series 320 is offered in a larger number of styles ensuring the right solution is available for all applications.
- Backlash free operation.
- Automatic re-engagement.
- One revolution synchronous re-engagement.
- Springs can be inspected and changed without removing the clutch from the drive train.
- Coil springs allow one standard design to accommodate the full torque range as opposed to regressive disc springs which can only accommodate a narrow torque band.

AUTOGARD SERIES 320 TORQUE LIMITER

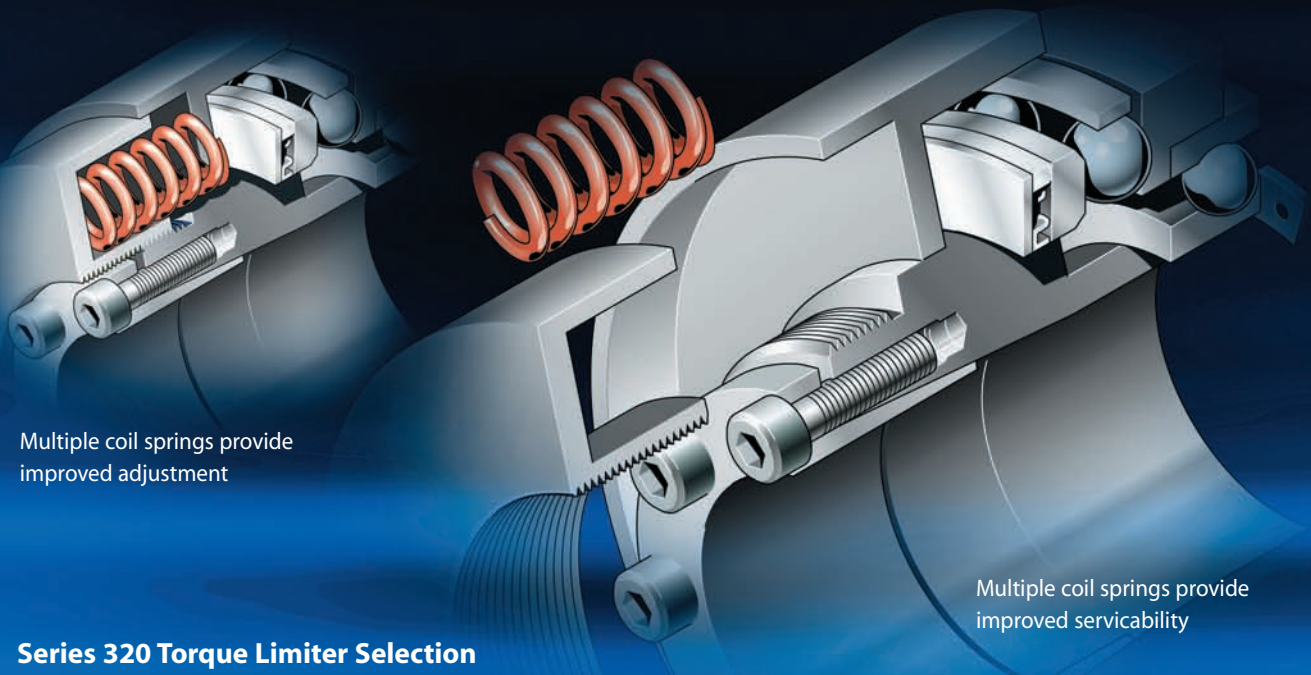

Multiple coil springs provide improved adjustment

Multiple coil springs provide improved servicability

Series 320 Torque Limiter Selection

Method

Data required for Torque Limiter Selection.

- Kilowatt and rpm of the driver.
- Shaft details of the driving and driven equipment.

(1) Calculate the maximum Torque (Nm):

$$\text{Torque} = (Kw \times 9550) / \text{rpm}$$

Select the Torque Limiter, which has a higher torque rating.

Consideration should be given to start torque or other special circumstances depending on the position chosen in the drive system. The accuracy of the Autogard Series 320 will ensure that disengagement will only take place when the pre-set torque is exceeded.

(2) Check the Limiting Conditions:

- Check the hub bore capacity is suitable
- Check the Torque Limiter dimensions such as Overall Length and Outside Diameters.

(3) Select and specify appropriate drive medium or coupling.

All Autogard Series 320 units may be supplied from the factory at a pre-set torque and with required Drive Medium assembled to the unit.

Example

Driver: Geared Motor (5 Kw at 120 rpm)

Driven equipment: Packaging Machine

Start-up Torque = 2 x Running Torque

System must be direct driven

Motor shaft: 55 mm Compressor shaft: 50 mm

$$\text{Torque (Nm)} = (5 Kw \times 9550) / 120$$

Maximum Nominal Torque = 398 Nm

Maximum Start-up Torque = 398 x 2 = 796 Nm

Series 320 Selection based on Start-up rating: 320-4

Coupling style 5, 6, 7 or 8 is acceptable for direct drives

Select a 320-4 / 8 : (Type 8)

Coupling Bore Capacity: 75 mm maximum

Keyed Hub Bore Capacity: 58 mm

The 320-4 / 8 is acceptable in this application

Ordering the 320 Series Torque Limiter

When ordering please provide the following designation:

Model – Size / Type / Feature / S_ Bore / S_ Bore

Feature: SR – Synchronous Reset (Standard)
RR – Rapid Reset (Optional)

Example: 320 – 2 / 8 / SR / S1-45 / S2-40

Refers to a Series 320 size 2 Torque Limiter designed for Synchronous Reset.

Bore S2 = 40 mm and Bore S3 = 45 mm

Also specify

- Torque setting or torque range required
- Pulley or sprocket details where required

AUTOGARD SERIES 320 STANDARD HUB

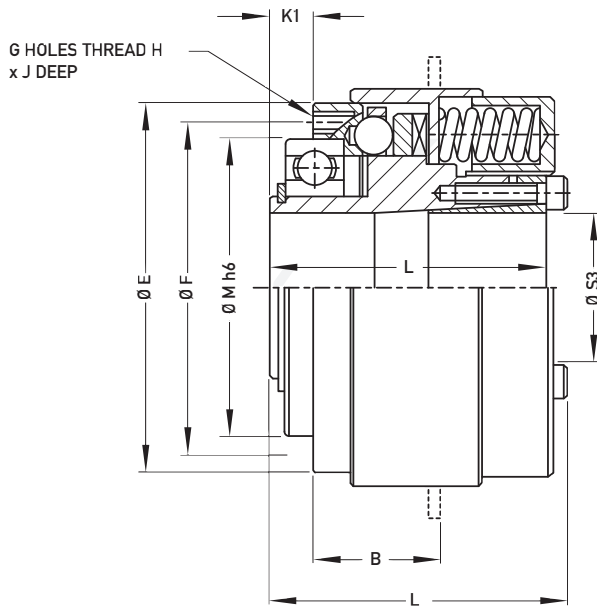

Type 1

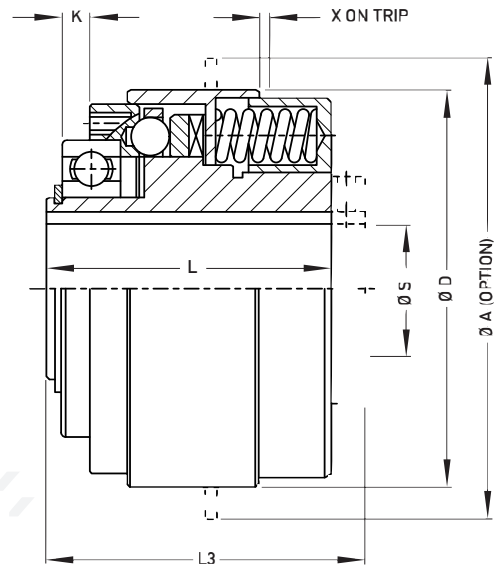

Type 2

Technical Data - Type 1 and Type 2

Size		01	0	1	2	3	4
Torque - Nm	Minimum	5	10	20	40	80	150
	Maximum	50	100	200	400	700	1500
Weight - Kg		1.00	1.91	2.89	4.47	7.41	12.95
Mass Moment of Inertia	Hub Side	0.0004	0.0009	0.0019	0.0044	0.0094	0.0257
	Flange Side	0.0001	0.0005	0.0010	0.0020	0.0040	0.0109

Dimensional Data (mm) - Type 1 and Type 2

Size		01	0	1	2	3	4
Bore (S3) - Clamped Collar	Minimum	10	15	22	32	35	42
	Maximum	20	28	35	45	55	65
Bore (S1) - Keyed Hub	Maximum	20	23	32	40	50	58
A		80	100	116	140	160	190
B		21	28	33	38	42	49
D		68	84	100	120	132	166
E		63.6	78.7	93.6	111	127	157
F		56	71	85	100	116	144
G		8	8	8	8	8	8
H		M4	M5	M6	M6	M8	M10
J		6	8	10	12.7	12.7	18
K		5	7	7	8	8	8
K1		8	11	12	12	16	16
L		47	60	71	84	95	110
L1		50	65	77	90	101	118
L3		52	68	80	95	105	122
M		47	62	75	90	100	115
X		1.2	1.6	1.7	2.2	2.4	2.8

- 1) The Drive Medium must be bored to suit dimension "M". Clutches may be ordered complete with Drive Medium (V-Belt Pulleys, Timing Pulleys etc.)
- 2) Weights and Inertia values are for unbored units.

AUTOGARD SERIES 320

LONG PROJECTING HUB

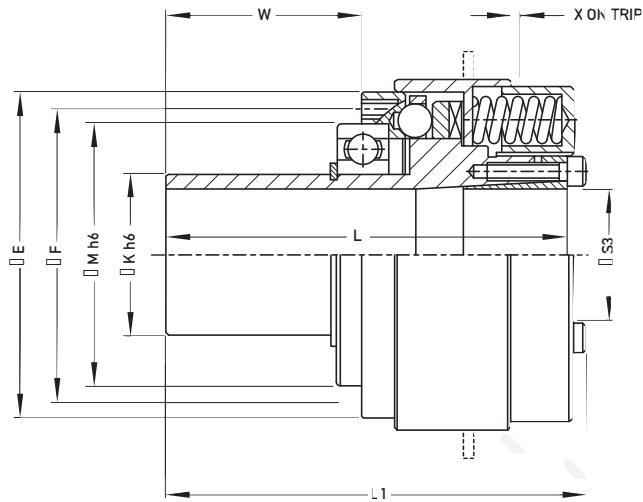

Type 3

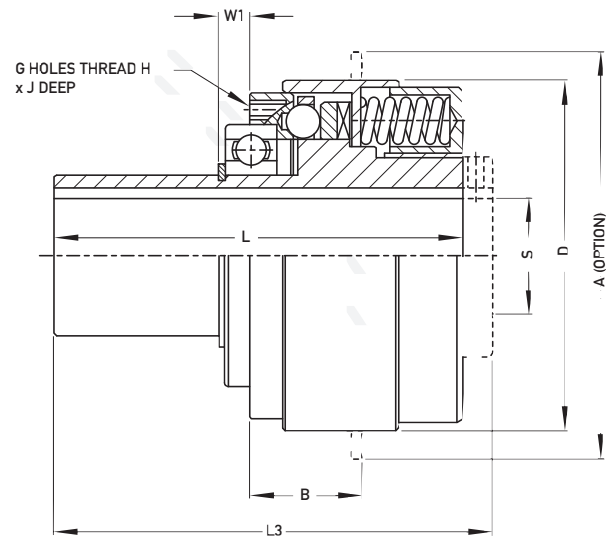

Type 4

Technical Data - Type 3 and Type 4

Size		01	0	1	2	3	4
Torque - Nm	Minimum	5	10	20	40	80	150
	Maximum	50	100	200	400	700	1500
Weight - Kg		1.16	2.28	3.5	5.64	9.05	15.83
Mass Moment of Inertia	Hub Side	0.0004	0.0010	0.0020	0.0048	0.0103	0.0277
	Flange Side	0.0002	0.0006	0.0012	0.0025	0.0048	0.0129

Dimensional Data (mm) - Type 3 and Type 4

Size		01	0	1	2	3	4
Bore (S3) - Clamped Collar	Minimum	10	15	22	32	35	42
	Maximum	20	28	35	45	55	65
Bore (S1) - Keyed Hub	Maximum	20	23	32	40	50	58
A		80	100	116	140	160	190
B		21	22	33	38	42	49
D		68	84	100	120	132	166
E		63.6	78.7	93.6	111	127	157
F		56	71	85	100	116	144
G		8	8	8	8	8	8
H		M4	M5	M6	M6	M8	M10
J		6	8	10	12.7	12.7	18
K		30	40	45	55	65	75
L		72	93	115	139	152	185
L1		75	97	120	145	158	193
L3		77	101	123	150	162	197
M		47	62	75	90	100	115
W		33	43	55	67	73	91
W1		6.5	8.5	8.8	10.6	10.5	10.5
X		1.2	1.6	1.7	2.2	2.4	2.8

- 1) The Drive Medium should be designed to fit dimension "K" and supported with suitable bearing. Clutches may be ordered complete with Drive Medium (V-Belt Pulleys, Timing Pulleys etc.)
- 2) Weights and Inertia values are for unbored units.

AUTOGARD SERIES 320

TORSIONALLY RIGID AUTOFLEX COUPLING

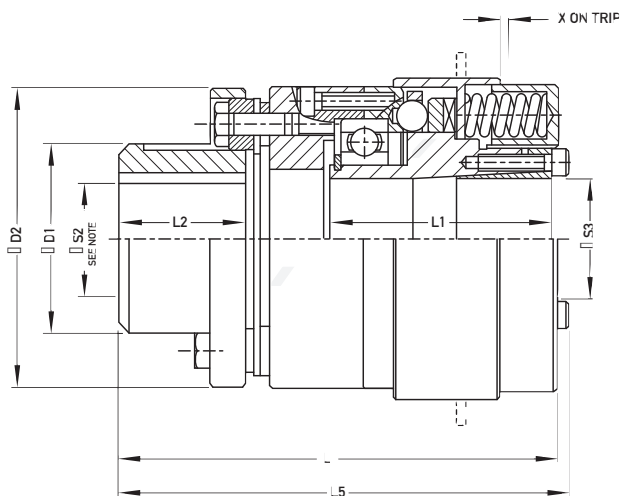

Type 5

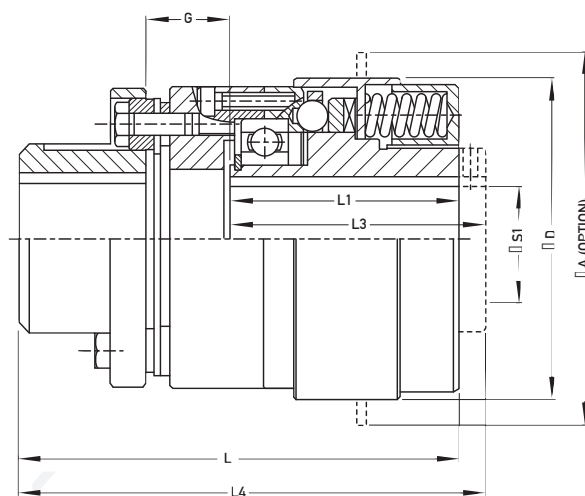

Type 6

Technical Data - Type 5 and Type 6

Size		01	0	1	2	3	4
Torque - Nm	Minimum	5	10	20	40	80	150
	Maximum	50	100	200	400	700	1500
Weight - Kg		2.24	3.04	4.75	8.05	13.22	25.39
Mass Moment of Inertia	Hub Side	0.0013	0.0017	0.0038	0.0097	0.0213	0.0662
	Flange Side	0.0011	0.0013	0.0030	0.0073	0.0159	0.0514
Maximum Axial Misalignment (mm)		0.66	0.66	0.76	0.97	1.12	1.47
Maximum Angular Misalignment (degrees)		0.5	0.5	0.5	0.5	0.5	0.5

Dimensional Data (mm) - Type 5 and Type 6

Size		01	0	1	2	3	4
Bore (S3) - Clamped Collar	Minimum	10	15	22	32	35	42
	Maximum	20	28	35	45	55	65
Bore (S2) - Keyed Hub	Maximum	30	30	40	50	70	90
Bore (S1) - Keyed Hub	Maximum	20	23	32	40	50	58
A		80	100	116	140	160	190
D		68	84	100	120	132	166
D1		44	44	53	71	91	123
D2		80	80	89	110	133	170
G		19	24	23	31	27	30
L		99	118	132	162	180	214
L1		47	61	72	85	95	110
L2		32.5	32.5	36.5	46.0	57.5	73.5
L3		52	68	80	95	105	122
L4		104	125	140	172	190	226
L5		102	122	136	166	185	222
X		1.2	1.6	1.7	2.2	2.4	2.8

1) Clamp Bushes and Ringfeder™ Collars may be supplied upon request - Consult your Autogard Sales Engineer.
 2) Weights and Inertia values are for unbored units.

AUTOGARD SERIES 320 SAMIFLEX ELASTIC COUPLING

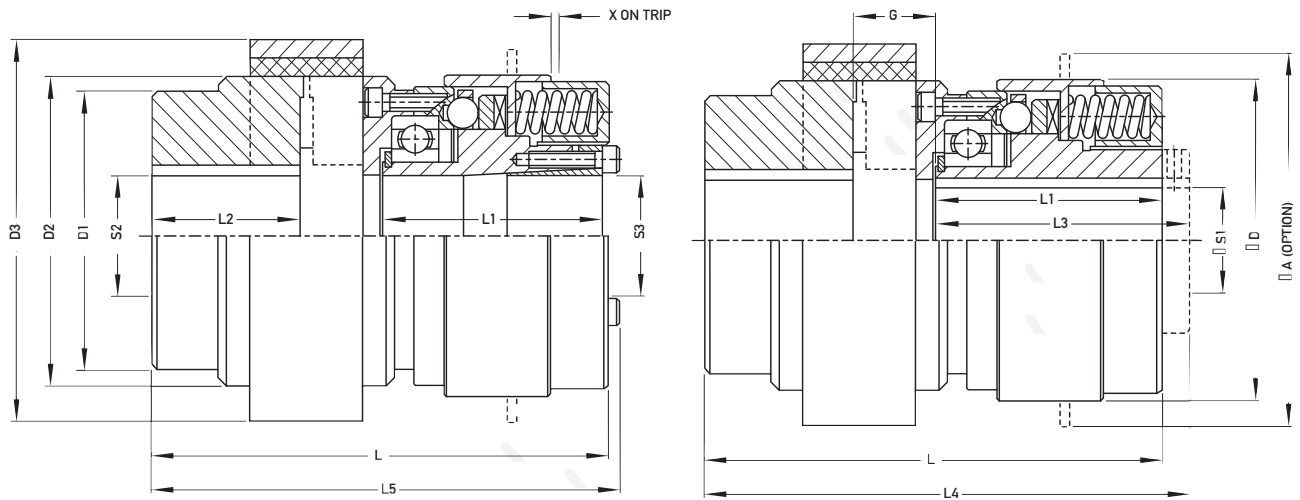

Type 7

Type 8

Technical Data - Type 7 and Type 8

Size		01	0	1	2	3	4
Torque - Nm	Minimum	5	10	20	40	80	150
	Maximum	50	100	200	400	700	1500
Weight - Kg		1.91	3.99	7.13	8.64	15.55	24.51
Mass Moment of Inertia	Hub Side	0.0012	0.0048	0.0172	0.0196	0.0678	0.1179
	Flange Side	0.0010	0.0044	0.0164	0.0172	0.0624	0.1031
Maximum Axial Misalignment (mm)		+0.5	+0.5	+0.7	+0.7	+0.8	+1.0
Maximum Radial Misalignment (mm)		0.10	0.10	0.15	0.15	0.20	0.20
Maximum Angular Misalignment (degrees)		2	2	2	2	1.3	1.3

Dimensional Data (mm) - Type 7 and Type 8

Size		01	0	1	2	3	4
Bore (S3) - Clamped Collar	Minimum	10	15	22	32	35	42
	Maximum	20	28	35	45	55	65
Bore (S2) - Coupling Hub	Minimum	15	18	20	20	25	26
	Maximum	38	42	42	42	70	75
Bore (S1) - Keyed Hub	Maximum	20	23	32	40	50	58
A		80	100	116	140	160	190
D		68	84	100	120	132	166
D1		65	80	85	85	110	125
D2		65	86	116	116	150	170
D3		83	111	144	144	182	202
G		15	21	29	31	36	34
L		97	127	156	171	194	214
L1		47	61	72	85	95	110
L2		35	46	56	56	63	70
L3		52	68	80	95	105	122
L4		102	134	164	181	204	226
L5		100	133	162	176	200	222
X		1.2	1.6	1.7	2.2	2.4	2.8

1) Clamp Bushes and Ringfeder™ Collars may be supplied upon request - Consult your Autogard Sales Engineer.
2) Weights and Inertia values are for unbored units.

OTHER AUTOGARD PRODUCTS



Autoflex Couplings



SamiFlex Elastic Couplings

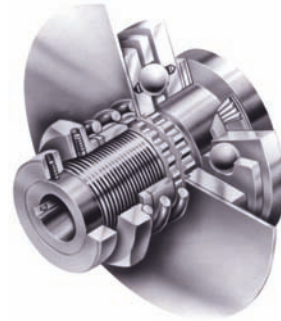

Autogard Series 200 Torque Limiters

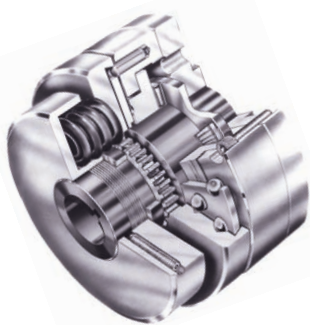

Autogard Series 400 Torque Limiters

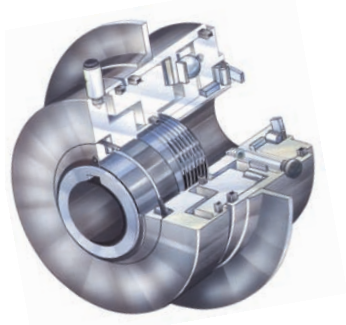

Autogard Series 600 Torque Limiters



Monitorq

Monitorq - Torque Sensors



Head Office
British Autogard Limited
Cirencester
Glos GL7 1YT
United Kingdom

Tel +44 (0) 1285 640333
Fax +44 (0) 1285 659476

Email sales@autogard.co.uk
Web www.autogard.com

American Autogard Corp.
Rockford, Illinois
Tel +1 815 229 3190
Fax +1 815 229 4615
sales.us@autogard.com

Autogard Italy
Milano, Italy
Tel +39 02 92 592083
Fax +39 02 39 305616
info@autogard.it

Autogard Asia Pacific P/L
Melbourne, Australia
Tel +61 (0) 3 9532 0901
Fax +61 (0) 3 9532 1032
sales@autogard.com.au

Your Local Distributor

