

# GUIDE LINEARI DI PRECISIONE

## PRECISION LINEAR GUIDEWAYS

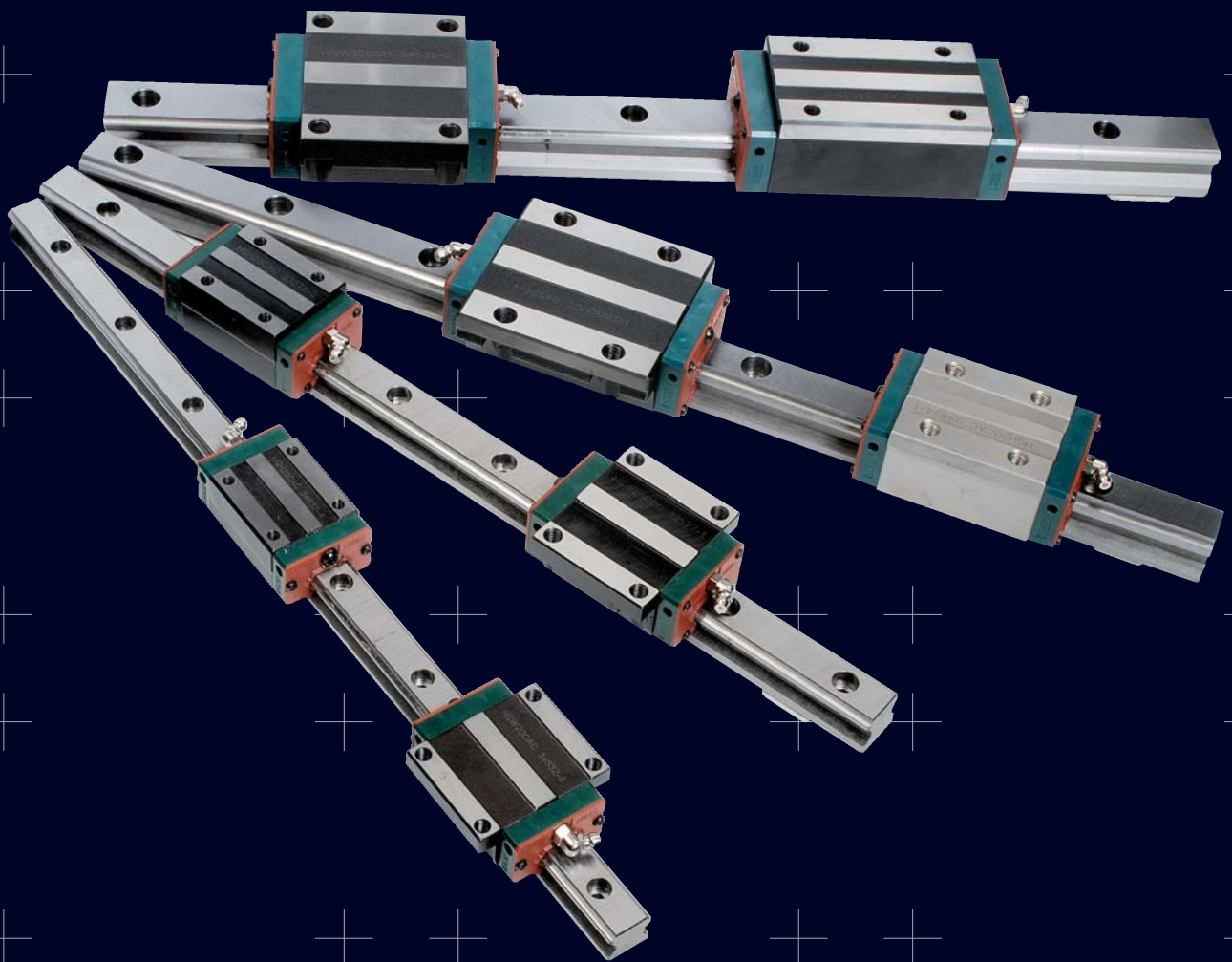

**JETEC**  
*COMPONENTI CONTROLLI SISTEMI DI MOTO*



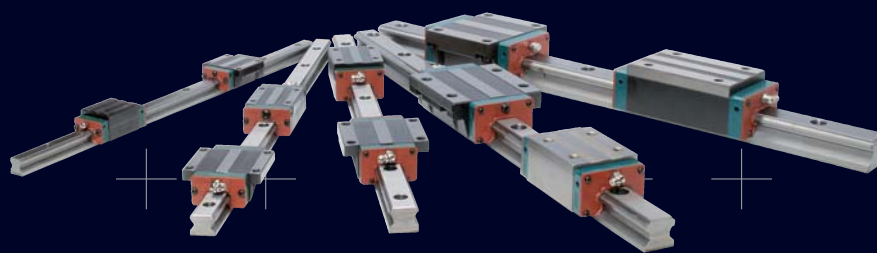

# GUIDE LINEARI DI PRECISIONE

## PRECISION LINEAR GUIDEWAYS

### INDICE / INDEX

Preface	1
<b>1. General Information</b>	<b>1</b>
1-1 Advantages and Features of Linear Guideways	1
1-2 The principles of Selecting Linear Guideways	2
1-3 Basic Load Ratings of Linear Guideways	3
1-4 Service Life of Linear Guideways	4
1-5 Applied Loads	5
1-6 Friction	9
1-7 Lubrication	10
1-8 Jointed Rail	10
1-9 Mounting Configurations	11
1-10 Mounting Procedures	12
<b>2. HIWIN Linear Guideway Product Series</b>	<b>17</b>
2-1 HG Series - Heavy Load Ball Type Linear Guideway	18
2-2 EG Series - Low Profile Ball Type Linear Guideway	36
2-3 MG Series - Miniature Linear Guideway	52
2-4 RG Series - High Rigidity Roller Type Linear Guideway	61
2-5 E2 Type - Self lubrication Kit for Linear Guideways	76
2-6 PG Type - Positioning Guideway	80
2-7 SE Type - Metallic End Cap Linear Guideway	87
2-8 Q1 Type - Quiet Linear Guideway, with synchMotion™ Technology	88
<b>3. HIWIN Linear Guideway Inquiry Form</b>	<b>96</b>

N.B.: Il Gruppo SETEC si riserva il diritto di apportare al presente catalogo tutte le modifiche che si renderanno necessarie senza preavviso e non si assume nessuna responsabilità per errata interpretazione dello stesso.  
 SETEC Group reserves the right to carry out, without notice, any modification on this catalogue that might be considered necessary and will not have any responsibility for misunderstanding of the contents.

# Preface

A linear guideway allows a type of linear motion that utilizes rolling elements such as balls or rollers. By using recirculating rolling elements between the rail and the block, a linear guideway can achieve high precision linear motion. Compared to a traditional slide, the coefficient of friction for a linear guideway is only 1/50th. Because of the restraint effect between the rails and the blocks, linear guideways can take up loads in both the up/down and the left/right directions. With these features, linear guideways can greatly enhance moving accuracy, especially, when accompanied with precision ball screws.

## 1. General Information

### 1-1 Advantages and Features of Linear Guideways

#### (1) High positional accuracy

When a load is driven by a linear motion guideway, the frictional contact between the load and the bed is rolling contact. The coefficient of friction is only 1/50th of traditional contact, and the difference between the dynamic and the static coefficient of friction is small. Therefore, there would be no slippage while the load is moving.

#### (2) Long life with high motion accuracy

With a traditional slide, errors in accuracy are caused by the counter flow of the oil film. Insufficient lubrication causes wear between the contact surfaces, which become increasingly inaccurate. In contrast, rolling contact has little wear; therefore, machines can achieve a long life with highly accurate motion.

#### (3) High speed motion is possible with a low driving force

Because linear guideways have little friction resistance, only a small driving force is needed to move a load. This results in greater power savings, especially in the moving parts of a system. This is especially true for the reciprocating parts.

#### (4) Equal loading capacity in all directions

With this special design, these linear guideways can take loads in either the vertical or horizontal directions. Conventional linear slides can only take small loads in the direction parallel to the contact surface. They are also more likely to become inaccurate when they are subjected to these loads.

#### (5) Easy installation

Installing a linear guideway is fairly easy. Grinding or milling the machine surface, following a recommended installation procedure, and tightening the bolts to their specified torque can achieve highly accurate linear motion.

#### (6) Easy lubrication

With a traditional sliding system, insufficient lubrication causes wear on the contact surfaces. Also, it can be quite difficult to supply sufficient lubrication to the contact surfaces because finding an appropriate lubrication point is not very easy. With a linear motion guideway, grease can be easily supplied through the grease nipple on the linear guideway block. It is also possible to utilize a centralized oil lubrication system by piping the lubrication oil to the piping joint.

#### (7) Interchangeability

Compared with traditional boxways or v-groove slides, linear guideways can be easily replaced should any damage occur. For high precision grades consider ordering a matched, non-interchangeable, assembly of a block and rail.

# Linear Guideways

## General Information

### 1-2 Selecting Linear Guideways

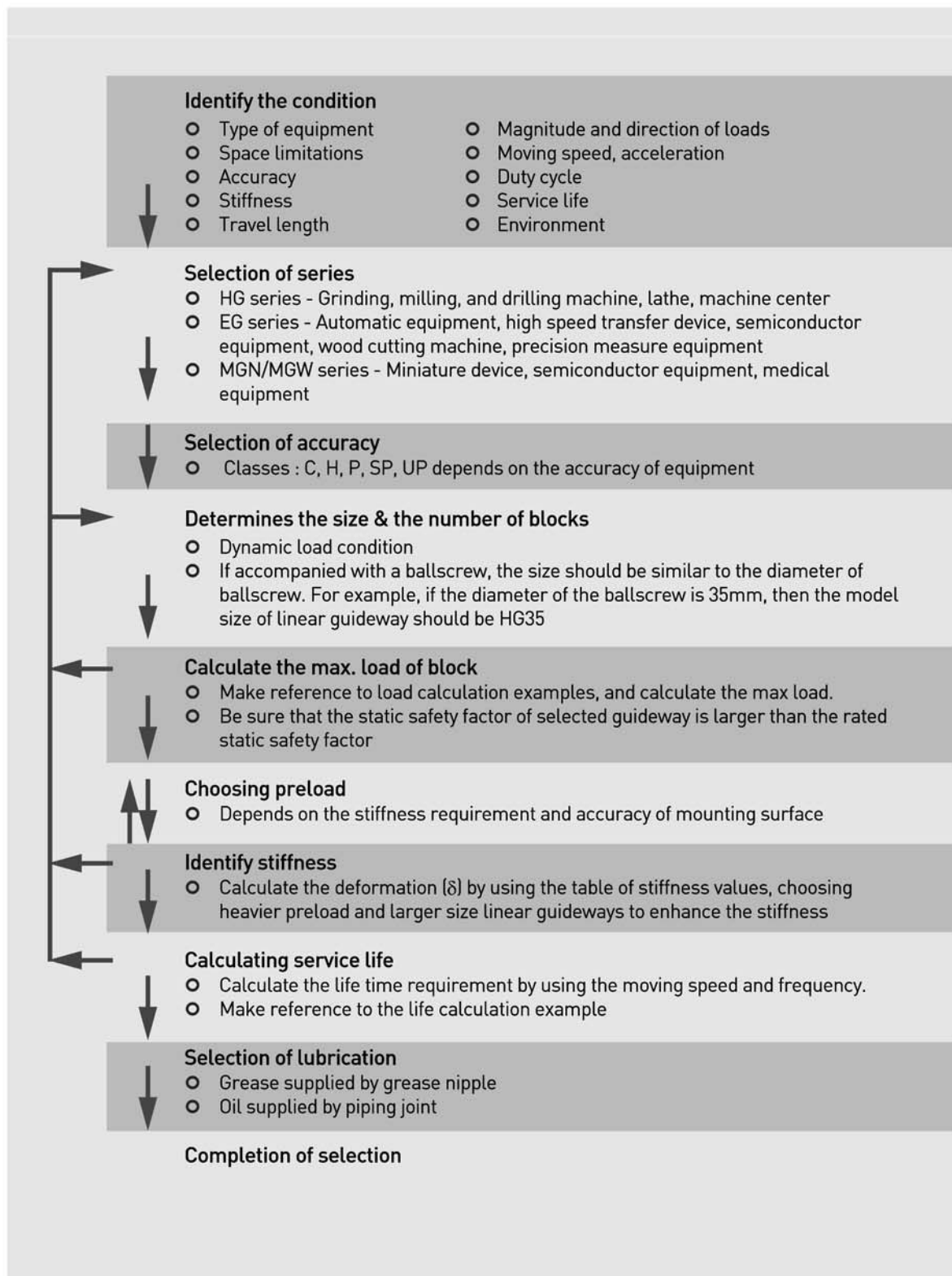

# 1-3 Basic Load Ratings of Linear Guideways

## 1-3-1 Basic Static Load

### (1) Static load rating (C<sub>0</sub>)

Localized permanent deformation will be caused between the raceway surface and the rolling elements when a linear guideway is subjected to an excessively large load or an impact load while either at rest or in motion. If the amount of this permanent deformation exceeds a certain limit, it becomes an obstacle to the smooth operation of the linear guideway. Generally, the definition of the basic static load rating is a static load of constant magnitude and direction resulting in a total permanent deformation of 0.0001 times the diameter of the rolling element and the raceway at the contact point subjected to the largest stress. The value is described in the dimension tables for each linear guideway. A designer can select a suitable linear guideway by referring to these tables. The maximum static load applied to a linear guideway must not exceed the basic static load rating.

### (2) Static permissible moment (M<sub>0</sub>)

The static permissible moment refers to a moment in a given direction and magnitude when the largest stress of the rolling elements in an applied system equals the stress induced by the Static Load Rating. The static permissible moment in linear motion systems is defined for three directions: M<sub>R</sub>, M<sub>P</sub> and M<sub>Y</sub>.

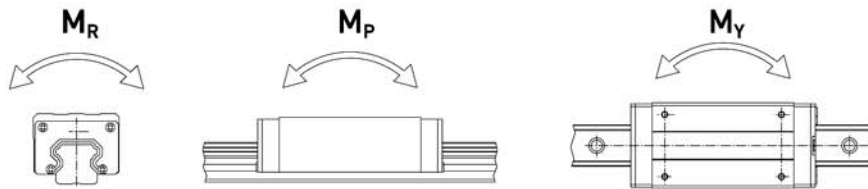

### (3) Static safety factor

This condition applies when the guideway system is static or under low speed motion. The static safety factor, which depends on environmental and operating conditions, must be taken into consideration. A larger safety factor is especially important for guideways subject to impact loads (See Table 1.1). The static load can be obtained by using Eq. 1.

**Table 1.1 Static Safety Factor**

Load Condition	f <sub>SL</sub> , f <sub>SM</sub> (Min.)
Normal Load	1.0-3.0
With impacts/vibrations	3.0-5.0

$$f_{SL} = \frac{C_0}{P} \text{ or } f_{SM} = \frac{M_0}{M} \dots\dots\dots \text{Eq.1.1}$$

- f<sub>SL</sub> : Static safety factor for simple load
- f<sub>SM</sub> : Static safety factor for moment
- C<sub>0</sub> : Static load rating (kN)
- M<sub>0</sub> : Static permissible moment (kN•mm)
- P : Calculated working load (kN)
- M : Calculated applying moment (kN•mm)

## 1-3-2 Basic Dynamic Load

### (1) Dynamic load rating (C)

The basic dynamic load rating is the load that does not change in direction or magnitude and results in a nominal life of 50km of operation for a linear guideway. The values for the basic dynamic load rating of each guideway are shown in dimension tables. They can be used to predict the service life for a selected linear guideway.

# Linear Guideways

## General Information

### 1-4 Service Life of Linear Guideways

#### 1-4-1 Service Life

When the raceway and the rolling elements of a linear guideway are continuously subjected to repeated stresses, the raceway surface shows fatigue. Flaking will eventually occur. This is called fatigue flaking. The life of a linear guideway is defined as the total distance traveled until fatigue flaking appears on the surface of the raceway or rolling elements.

#### 1-4-2 Nominal Life (L)

The service life varies greatly even when the linear motion guideways are manufactured in the same way or operated under the same motion conditions. For this reason, nominal life is used as the criteria for predicting the service life of a linear motion guideway. The nominal life is the total distance that 90% of a group of identical linear motion guideways, operated under identical conditions, can travel without flaking. When the basic dynamic rated load is applied to a linear motion guideway, the nominal life is 50km.

#### 1-4-3 Calculation of Nominal Life

The acting load will affect the nominal life of a linear guideway. Based on the selected basic dynamic rated load and the actual load, the nominal life can be calculated by using Eq. 1.2.

$$L = \left(\frac{C}{P}\right)^3 \cdot 50\text{km} = \left(\frac{C}{P}\right)^3 \cdot 31\text{mile} \quad \dots\dots\dots \text{Eq.1.2}$$

- L : Nominal life
- C : Basic dynamic load rating
- P : Actual load

If the environmental factors are taken into consideration, the nominal life is influenced greatly by the motion conditions, the hardness of the raceway, and the temperature of the linear guideway. The relationship between these factors is expressed in Eq. 1.3.

$$L = \left(\frac{f_h \cdot f_t \cdot C}{f_w \cdot P_c}\right)^3 \cdot 50\text{km} = \left(\frac{f_h \cdot f_t \cdot C}{f_w \cdot P_c}\right)^3 \cdot 31\text{mile} \quad \dots\dots\dots \text{Eq.1.3}$$

- L : Nominal life
- $f_h$  : Hardness factor
- C : Basic dynamic load rating
- $f_t$  : Temperature factor
- $P_c$  : Calculated load
- $f_w$  : Load factor

#### 1-4-4 Factors of Normal Life

##### (1) Hardness factor ( $f_h$ )

In general, the raceway surface in contact with the rolling elements must have the hardness of HRC 58~62 to an appropriate depth. When the specified hardness is not obtained, the permissible load is reduced and the nominal life is decreased. In this situation, the basic dynamic load rating and the basic static load rating must be multiplied by the hardness factor for calculation.

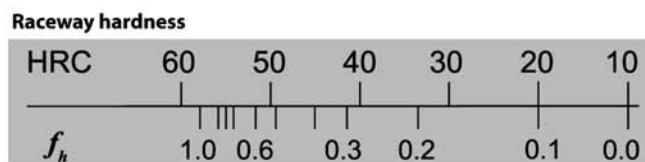

## (2) Temperature factor ( $f_t$ )

When the temperature of a linear guideway exceeds 100°C, the permissible load is reduced and the nominal life is decreased. Therefore, the basic dynamic load rating and the basic static load rating must be multiplied by the temperature factor.

### Temperature



## (3) Load factor ( $f_w$ )

The loads acting on a linear guideway include the weight of slide, the inertia load at the times of start and stop, and the moment loads caused by overhanging. These load factors are especially difficult to estimate because of mechanical vibrations and impacts. Therefore, the load on a linear guideway should be divided by the empirical factor.

**Table 1.2 Load factor**

### HG/EG Series

Loading Condition	Service Speed	$f_w$
No impacts & vibration	$V \leq 15$ m/min	1 ~ 1.2
Small impacts	$15$ m/min $< V \leq 60$ m/min	1.2 ~ 1.5
Normal load	$60$ m/min $< V \leq 120$ m/min	1.5 ~ 2.0
With impacts & vibration	$V > 120$ m/min	2.0 ~ 3.5

### MG Series

Loading Condition	Service Speed	$f_w$
No impacts & vibration	$V \leq 15$ m/min	1 ~ 1.5
Normal load	$15$ m/min $< V \leq 60$ m/min	1.5 ~ 2.0
With impacts & vibration	$V > 60$ m/min	2.0 ~ 3.5

## 1-4-5 Calculation of Service Life ( $L_h$ )

Transform the nominal life into the service life time by using speed and frequency.

$$L_h = \frac{L \cdot 10^3}{V_e \cdot 60} = \left( \frac{C}{P} \right)^3 \cdot \frac{50 \cdot 10^3}{V_e \cdot 60} \text{ hr} \quad \dots\dots\dots \text{Eq.1.4}$$

- $L_h$  : Service life (hr)
- $L$  : Nominal life (km)
- $V_e$  : Speed (m/min)
- $C/P$  : Load factor

## 1-5 Applied Loads

### 1-5-1 Calculation of Load

Several factors affect the calculation of loads acting on a linear guideway (such as the position of the object's center of gravity, the thrust position, and the inertial forces at the time of start and stop). To obtain the correct load value, each load condition should be carefully considered.

# Linear Guideways

## General Information

### (1) Load on one block

Table 1.3 Calculation example of loads on block

Patterns	Loads layout	Load on the block and displacement of point U
		$P_1 = \frac{W}{4} + \frac{F}{4} + \frac{F \cdot a}{2c} + \frac{F \cdot b}{2d}$ $P_2 = \frac{W}{4} + \frac{F}{4} + \frac{F \cdot a}{2c} - \frac{F \cdot b}{2d}$ $P_3 = \frac{W}{4} + \frac{F}{4} - \frac{F \cdot a}{2c} + \frac{F \cdot b}{2d}$ $P_4 = \frac{W}{4} + \frac{F}{4} - \frac{F \cdot a}{2c} - \frac{F \cdot b}{2d}$ $\delta x = -Zu \cdot \frac{P_1 - P_2}{d \cdot K}, \quad \delta y = -Zu \cdot \frac{P_1 - P_3}{c \cdot K}$ $\delta z = -\frac{F}{4 \cdot K} + Xu \cdot \frac{P_1 - P_2}{d \cdot K} - Yu \cdot \frac{P_1 - P_3}{c \cdot K}$
		$P_1 = \frac{W}{4} + \frac{F}{4} + \frac{F \cdot a}{2c} + \frac{F \cdot b}{2d}$ $P_2 = \frac{W}{4} + \frac{F}{4} + \frac{F \cdot a}{2c} - \frac{F \cdot b}{2d}$ $P_3 = \frac{W}{4} + \frac{F}{4} - \frac{F \cdot a}{2c} + \frac{F \cdot b}{2d}$ $P_4 = \frac{W}{4} + \frac{F}{4} - \frac{F \cdot a}{2c} - \frac{F \cdot b}{2d}$ $\delta x = -Zu \cdot \frac{P_1 - P_2}{d \cdot K}, \quad \delta y = -Zu \cdot \frac{P_1 - P_3}{c \cdot K}$ $\delta z = -\frac{F}{4 \cdot K} + Xu \cdot \frac{P_1 - P_2}{d \cdot K} - Yu \cdot \frac{P_1 - P_3}{c \cdot K}$
		$P_1 = P_3 = \frac{W}{4} - \frac{F \cdot l}{2d}$ $P_2 = P_4 = \frac{W}{4} + \frac{F \cdot l}{2d}$ $\delta x = -Zu \cdot \frac{P_1 + P_2}{d \cdot K}$ $\delta y = 0$ $\delta z = -Xu \cdot \frac{P_1 + P_2}{d \cdot K}$
		$P_1 - P_4 = -\frac{W \cdot h}{2d} + \frac{F \cdot l}{2d}$ $\delta x = -Zu \cdot \frac{P_1 + P_2}{d \cdot K}$ $\delta y = 0$ $\delta z = -Xu \cdot \frac{P_1 + P_2}{d \cdot K}$
		$P_1 - P_4 = -\frac{W \cdot h}{2c} + \frac{F \cdot l}{2c}$ $P_{11} = P_{13} = \frac{W}{4} + \frac{F}{4} + \frac{F \cdot k}{2d}$ $P_{12} = P_{14} = \frac{W}{4} + \frac{F}{4} - \frac{F \cdot k}{2d}$ $\delta x = -Yu \cdot \frac{P_{11} - P_{12}}{d \cdot K}$ $\delta y = -\frac{F}{4 \cdot K} + Xu \cdot \frac{P_{11} - P_{12}}{d \cdot K} - Zu \cdot \frac{P_1 + P_3}{c \cdot K}$ $\delta z = -Yu \cdot \frac{P_1 + P_3}{c \cdot K}$



## [2] Loads with inertia forces

Table 1.4 Calculation Examples for Loads with Inertia Forces

Considering the acceleration and deceleration	Load on one block
<p> <math>F</math> : External force [N]  <math>W</math> : Weight of object [N]  <math>g</math> : Gravitational acceleration [9.8m/sec<sup>2</sup>]         </p>	<ul style="list-style-type: none"> <li>○ Constant velocity  <math>P_1 \sim P_4 = \frac{W}{4}</math> </li> <li>○ Acceleration  <math>P_1 = P_3 = \frac{W}{4} + \frac{1}{2} \cdot \frac{W}{g} \cdot \frac{V_c}{t_1} \cdot \frac{l}{d}</math>  <math>P_2 = P_4 = \frac{W}{4} - \frac{1}{2} \cdot \frac{W}{g} \cdot \frac{V_c}{t_1} \cdot \frac{l}{d}</math> </li> <li>○ Deceleration  <math>P_1 = P_3 = \frac{W}{4} - \frac{1}{2} \cdot \frac{W}{g} \cdot \frac{V_c}{t_3} \cdot \frac{l}{d}</math>  <math>P_2 = P_4 = \frac{W}{4} + \frac{1}{2} \cdot \frac{W}{g} \cdot \frac{V_c}{t_3} \cdot \frac{l}{d}</math> </li> </ul>

### 1-5-2 Calculation of The Mean Load for Variable Loading

When the load on a linear guideway fluctuates greatly, the variable load condition must be considered in the life calculation. The definition of the mean load is the load equal to the bearing fatigue load under the variable loading conditions. It can be calculated by using table 1.5.

Table 1.5 Calculation Examples for Mean Load ( $P_m$ )

Operation Condition	Mean load
Step load 	$P_m = \sqrt[3]{1/L(P_1^3 \cdot L_1 + P_2^3 \cdot L_2 + \dots + P_n^3 \cdot L_n)}$ <p> <math>P_m</math> : Mean load  <math>P_n</math> : Stepping  <math>L</math> : Total running distance  <math>L_n</math> : Running distance under load <math>P_n</math> </p>
Linear variation 	$P_m = 1/3 (P_{min} + 2 \cdot P_{max})$ <p> <math>P_m</math> : Mean load  <math>P_{min}</math> : Min. Load  <math>P_{max}</math> : Max. Load         </p>
Sinusoidal loading 	$P_m = 0.65 \cdot P_{max}$ <p> <math>P_m</math> : Mean load  <math>P_{max}</math> : Max. Load         </p>

# Linear Guideways

## General Information

### 1-5-3 Calculation for Bidirectional Equivalent Loads

HIWIN linear guideways can accept loads in several directions simultaneously. To calculate the service life of the guideway when the loads appear in multiple directions, calculate the equivalent load ( $P_e$ ) by using the equations below.

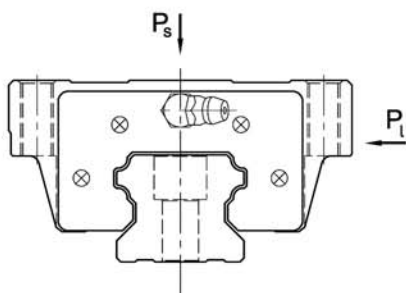

HG/EG Series

$$P_e = P_s + P_l \quad \dots\dots\dots \text{Eq.1.5}$$

MG Series

$$\text{when } P_s > P_l \quad P_e = P_s + 0.5 \cdot P_l \quad \dots\dots\dots \text{Eq.1.6}$$

$$\text{when } P_l > P_s \quad P_e = P_l + 0.5 \cdot P_s \quad \dots\dots\dots \text{Eq.1.7}$$

### 1-5-4 Calculation Example for Service Life

A suitable linear guideway should be selected based on the acting load. The service life is calculated from the ratio of the working load and the basic dynamic load rating.

**Table 1.6 Calculation Example for Service Life**

Type of Linear Guideway	Dimension of device	Operating condition
Type: HGH 30 CA	d : 600 mm	Weight (W) : 4 kN
C : 38.74 kN	c : 400 mm	Acting force (F) : 1 kN
C <sub>0</sub> : 83.06 kN	h : 200 mm	Temperature: normal temperature
Preload: ZA	l : 250 mm	Load status: normal load

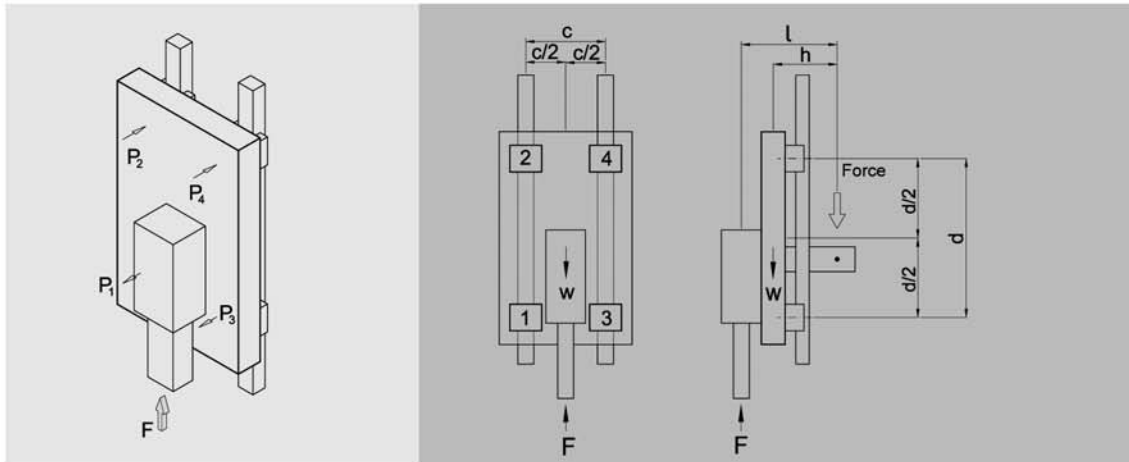

- Calculation of acting loads

$$P_1 \sim P_4 = \frac{W \times h}{2d} - \frac{F \times l}{2d} = \frac{4 \times 200}{2 \times 600} - \frac{1 \times 250}{2 \times 600} = 0.458 \text{ (kN)}$$

$$P_{\max} = 0.458 \text{ (kN)}$$

- P<sub>c</sub> is equal to the sum of P<sub>max</sub> and preload

$$P_c = P_{\max} + P_z = 0.458 + (38.74 \times 0.07) = 3.17 \text{ (kN)}$$

- Calculation for life L

$$L = \left( \frac{f_h \times f_t \times C}{f_w \times P_c} \right)^3 \times 50 = \left( \frac{1 \times 1 \times 38.74}{2 \times 3.17} \right)^3 \times 50 = 11,400 \text{ (km)}$$

## 1-6 Friction

As mentioned in the preface, a linear guideway allows a type of rolling motion, which is achieved by using balls. The coefficient of friction for a linear guideway can be as little as 1/50th of a traditional slide. Generally, the coefficient of friction of linear guideway is about 0.004.

When a load is 10% or less than the basic static load rate, the most of the resistance comes from the grease viscosity and frictional resistance between balls. In contrast, if the load is more than the basic static load rating, the resistance will mainly come from the load.

$$F = \mu \cdot W + S \quad \dots \dots \dots \text{Eq.1.8}$$

- F: Friction (kN)
- S: Friction resistance (kN)
- μ: Coefficient of friction
- W: Normal loads (kN)

# Linear Guideways

## General Information

### 1-7 Lubrication

#### 1-7-1 Grease

Each linear guideway is lubricated with lithium soap based grease before shipment. After the linear guideway is installed, we recommend that the guideway be re-lubricated every 100 km. It is possible to carry out the lubrication through the grease nipple. Generally, grease is applied for speeds that do not exceed 60 m/min faster speeds will require high-viscosity oil as a lubricant.

$$T = \frac{100 \cdot 1000}{V_e \cdot 60} \text{ hr} \quad \dots\dots\dots \text{Eq.1.9}$$

T : Feeding frequency of oil (hour)  
 V<sub>e</sub> : speed (m/min)

#### 1-7-2 Oil

The recommended viscosity of oil is about 32~150cSt. The standard grease nipple may be replaced by an oil piping joint for oil lubrication. Since oil evaporates quicker than grease, the recommended oil feed rate is approximate 0.3cm<sup>3</sup>/hr.

### 1-8 Jointed Rail

Jointed rail should be installed by following the arrow sign and ordinal number which is marked on the surface of each rail.

For matched pair, jointed rails, the jointed positions should be staggered. This will avoid accuracy problems due to discrepancies between the 2 rails (see figure).

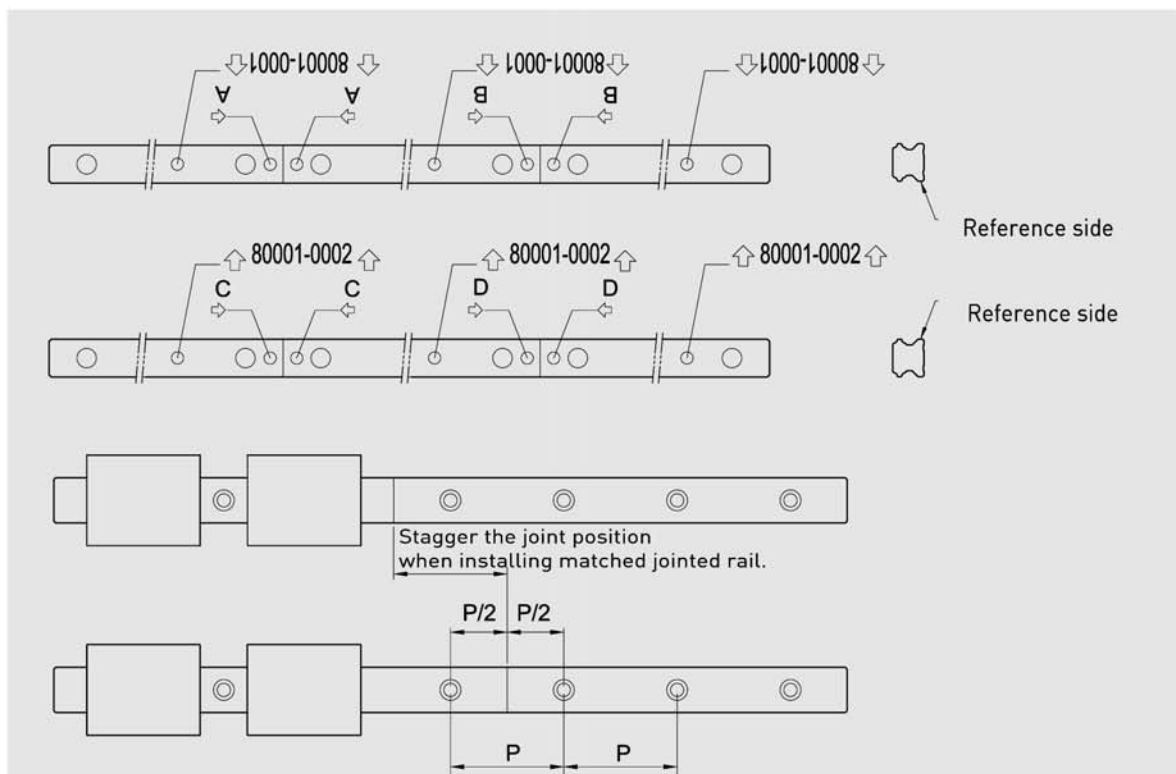

## 1-9 Mounting Configurations

Linear guideways have equal load ratings in the radial, reverse radial and lateral directions. The application depends on the machine requirements and load directions. Typical layouts for linear guideways are shown below:

Use of one rail and mounting reference side

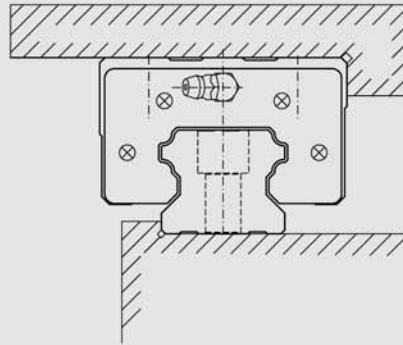

use of two rails(block movement)

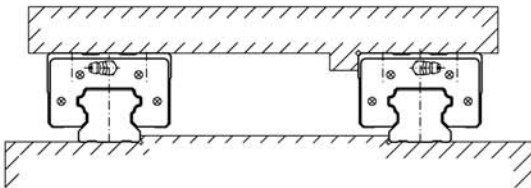

use of two rails(block fixed)

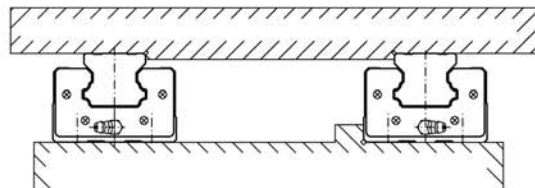

use of two external rails

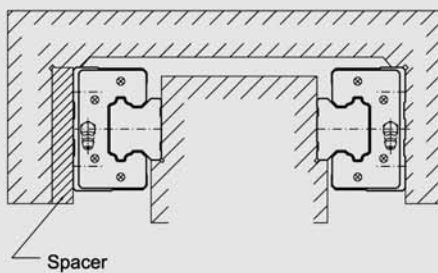

use of two internal rails

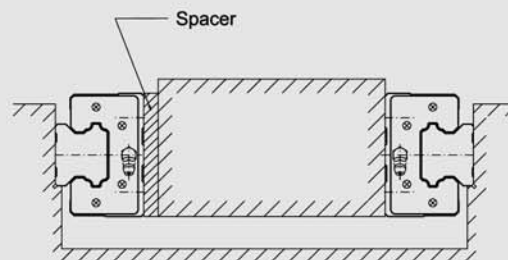

total surface fixed installation

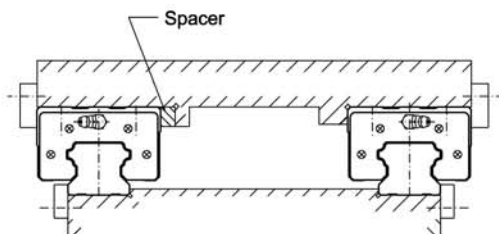

HGW type block with mounting holes in different directions.

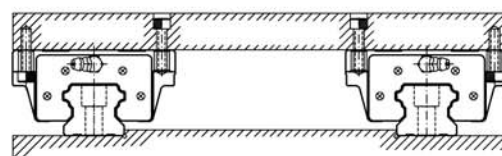

# Linear Guideways

## General Information

### 1-10 Mounting Procedures

Three installation methods are recommended based on the required running accuracy and the degree of impacts and vibrations.

#### 1-10-1 Master and Subsidiary Guide

For non-interchangeable type Linear Guideways, there are some differences between the master guide and subsidiary guide. The accuracy of the master guide's datum plane is better than the subsidiary's and it can be a reference side for installation. There is a mark "MA" printed on the rail, as shown in the figure below.

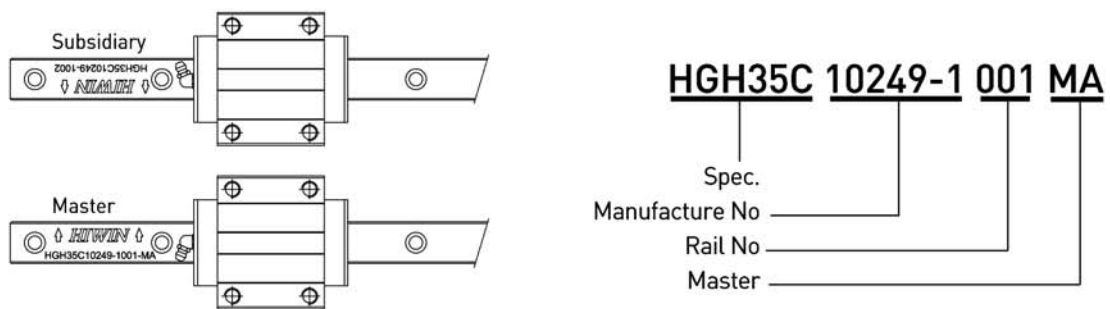

#### 1-10-2 Installation to Achieve High Accuracy and Rigidity

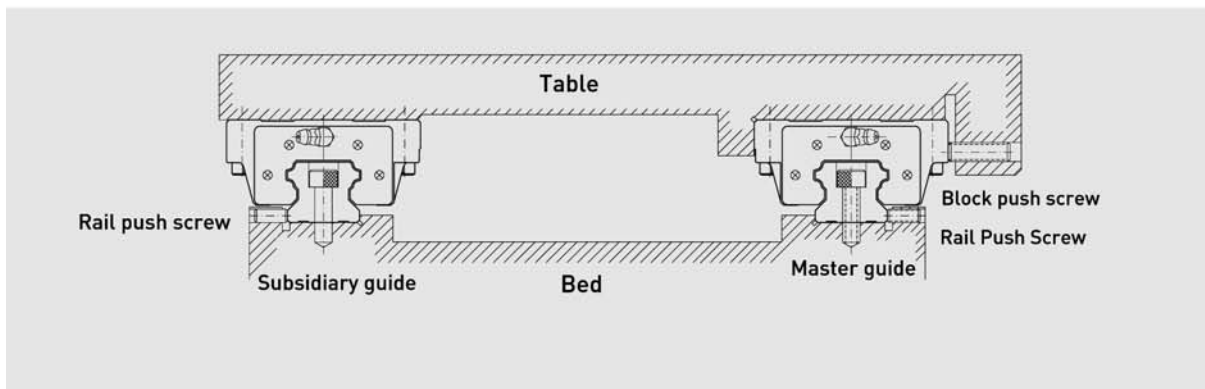

## (1) Mounting methods

It is possible that the rails and the blocks will be displaced when the machine is subjected to vibrations and impacts. To eliminate these difficulties and achieve high running accuracy, the following four methods are recommended for fixing.

Mounting with a push plate

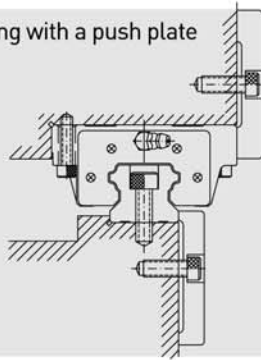

Mounting with push screws

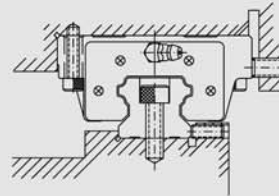

Mounting with taper gib

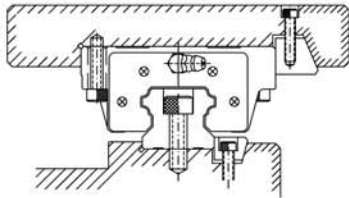

Mounting with needle roller

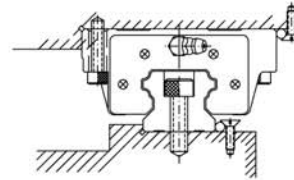

## (2) Procedure of rail installation

- 1 Before starting, remove all dirt from the mounting surface of the machine.

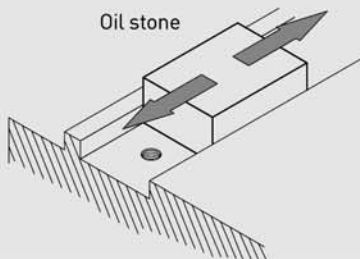

- 2 Place the linear guideway gently on the bed. Bring the guideway into close contact with the datum plane of the bed.

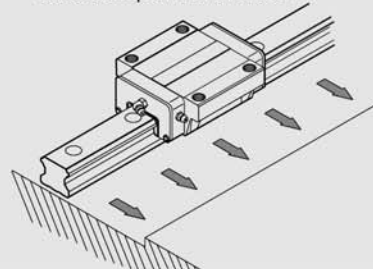

- 3 Check for correct thread engagement when inserting a bolt into the mounting hole while the rail is being placed on the mounting surface of the bed.

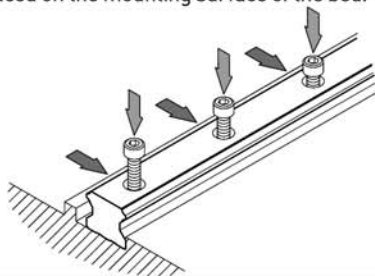

- 4 Tighten the push screws sequentially to ensure close contact between the rail and the side datum plane.

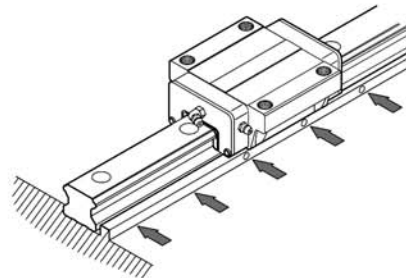

- 5 Tighten the mounting bolts with a torque wrench to the specified torque.

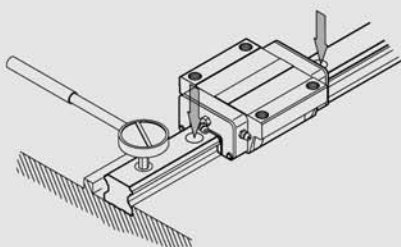

- 6 Install the remaining linear guideway in the same way.

# Linear Guideways

## General Information

### (3) Procedure of block installation

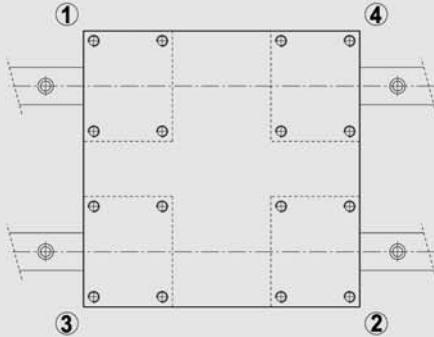

- Place the table gently on the blocks. Next, tighten the block mounting bolts temporarily.
- Push the blocks against the datum plane of the table and position the table by tightening the push screws.
- The table can be fixed uniformly by tightening the mounting bolts on master guide side and subsidiary side in 1 to 4 sequences.

### 1-10-3 Installation of the Master Guide without Push Screws

To ensure parallelism between the subsidiary guide and the master guide without push screws, the following rail installation methods are recommended. The block installation is the same as mentioned previously.

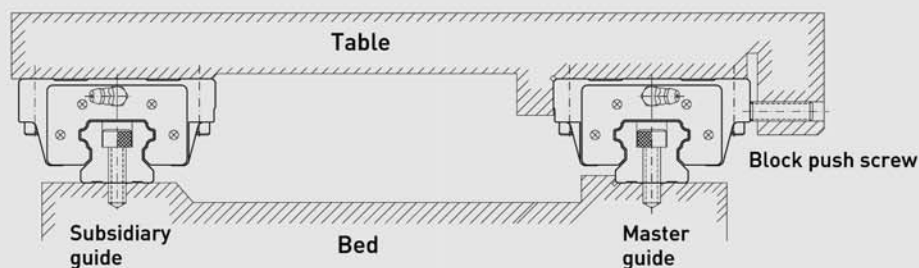

#### (1) Installation of the rail on the subsidiary guide side

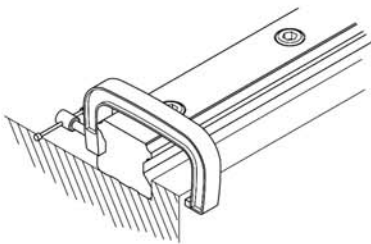

- **Using a vice**  
Place the rail into the mounting plane of the bed. Tighten the mounting bolts temporarily; then use a vice to push the rail against the side datum plane of the bed. Tighten the mounting bolts in sequence to the specified torque.



## (2) Installation of the rail on the subsidiary guide side

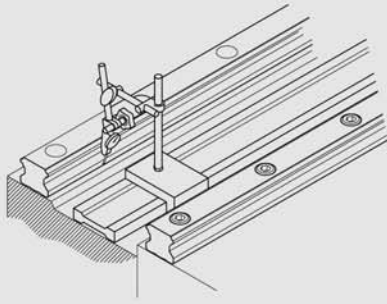

### ○ Method with use of a straight edge

Set a straight edge between the rails parallel to the side datum plane of the rail on the master guide side by using a dial gauge. Use the dial gauge to obtain the straight alignment of the rail on the subsidiary guide side. When the rail on the subsidiary guide side is parallel to the master side, tighten the mounting bolts in sequence from one end of the rail to the other.

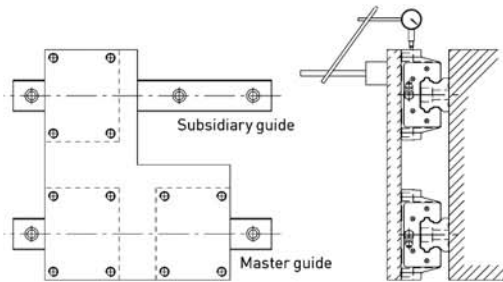

### ○ Method with use of a table

Fix two blocks on the master guide side to the table. Temporarily fix the rail and one block on the subsidiary guide side to the bed and the table. Fix a dial gauge stand on the table surface and bring it into contact with the side of the block on the subsidiary guide side. Move the table from one end of the rail to the other. While aligning the rail on the subsidiary side parallel to the rail on the master guide side, tighten the bolts in sequence.

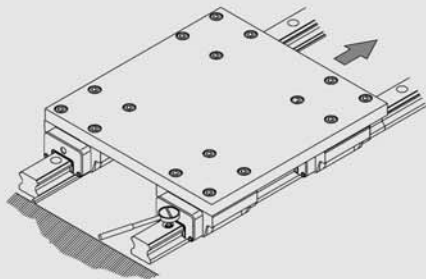

### ○ Method following the master guide side

When a rail on the master guide side is correctly tightened, fix both blocks on the master guide side and one of the two blocks on the subsidiary guide side completely to the table.

When moving the table from one end of the rail, tighten the mounting bolts on the subsidiary guide side completely.

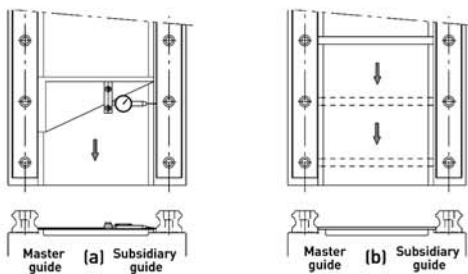

### ○ Method with use of a jig

Use a special jig to ensure the rail position on the subsidiary guide side. Tighten the mounting bolts to the specified torque in sequence.

# Linear Guideways

## General Information

### 1-10-4 When There Is No Side Surface of The Bed On The Master Guide Side

To ensure parallelism between the subsidiary guide and the master guide when there is no side surface, the following rail installation method is recommended. The installation of the blocks is the same as mentioned previously.

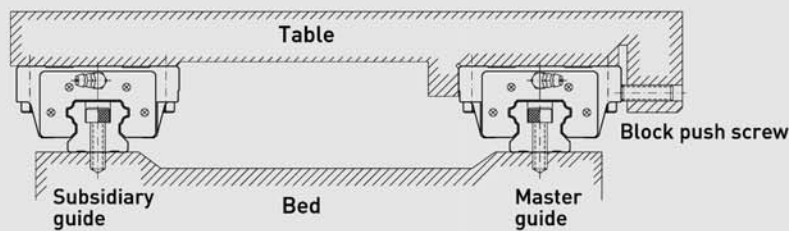

#### (1) Installation of the rail on the master guide side

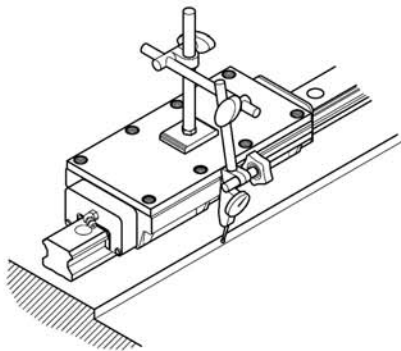

- **Using a provisional datum plane**  
Two blocks are fixed in close contact by the measuring plate. A datum plane provided on the bed is used for straight alignment of the rail from one end to the other. Move the blocks and tighten the mounting bolts to the specified torque in sequence.

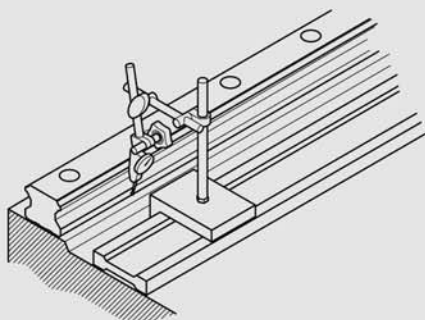

- **Method with use of a straight edge**  
Use a dial gauge and a straight edge to confirm the straightness of the side datum plane of the rail from one end to the other. Make sure the mounting bolts are tightened securely in sequence.

#### (2) Installation of the rail on the subsidiary guide side

The method of installation for the rail on the subsidiary guide side is the same as the case without push screws.

## 2. HIWIN Linear Guideway Product Series

Hiwin has developed numerous products to satisfy various needs of customers. HG series is a heavy load ball-type guideway for machine tools which requires high accuracy and rigidity; the EG series is a low-profile guideway for the automation industry which requires high speed and smooth motion; and the MG Series is a miniature type for semiconductor equipment and other miniature equipment.

### (1) Types & series

**Table 2.1 Types & Series**

Series	Assembly Height	Load	Square	Flange		
			Tap hole	Tap hole	Drilled hole	Combination
HG	High	Heavy Load	HGH-CA	-	-	-
		Super Heavy Load	HGH-HA	-	-	-
	Low	Heavy Load	-	HGW-CA	HGW-CB	HGW-CC
		Super Heavy Load	-	HGW-HA	HGW-HB	HGW-HC
EG	Low	Medium Load	EGH-SA	EGW-SA	EGW-SB	-
		Heavy Load	EGH-CA	EGW-CA	EGW-CB	-
MGN	-	Standard	MGN-C	-	-	-
		Long	MGN-H	-	-	-
MGW	-	Standard	MGW-C	-	-	-
		Long	MGW-H	-	-	-

### (2) Accuracy classes

**Table 2.2 Accuracy Classes**

Series	Assembly Type					Interchangeable Type		
	Normal	High	Precision	Super Precision	Ultra Precision	Normal	High	Precision
	(C)	(H)	(P)	(SP)	(UP)	(C)	(H)	(P)
HG	●	●	●	●	●	●	●	●
EG	●	●	●	●	●	●	●	●
MGN	●	●	●	-	-	●	●	●
MGW	●	●	●	-	-	-	-	-

### (3) Classification of preload

**Table 2.3 Preload**

Series	Non-interchangeable Type			Interchangeable Type	
	Light preload (Z0)	Medium Preload (ZA)	Heavy Preload (ZB)	Light Preload (Z0)	Medium Preload (ZA)
HG	●	●	●	●	●
EG	●	●	●	●	●

Series	Non-interchangeable Type			Interchangeable Type		
	Light Clearance (ZF)	Very Light Preload (Z0)	Light Preload (Z1)	Light Clearance (ZF)	Very Light Preload (Z0)	Light Preload (Z1)
MGN	●	●	●	●	●	●
MGW	●	●	●	-	-	-

# Linear Guideways

## HG Series

### 2-1 HG Series - Heavy Load Ball Type Linear Guideway

HG series linear guideways are designed with load capacity and rigidity higher than other similar products with circular-arc groove and structure optimization. It features equal load ratings in the radial, reverse radial and lateral directions, and self-aligning to absorb installation-error. Thus, HIWIN HG series linear guideways can achieve a long life with high speed, high accuracy and smooth linear motion.

#### 2-1-1 Features of HG Series

##### (1) Self-aligning capability

By design, the circular-arc groove has contact points at 45 degrees. HG series can absorb most installation errors due to surface irregularities and provide smooth linear motion through the elastic deformation of rolling elements and the shift of contact points. Self-aligning capability, high accuracy and smooth operation can be obtained with an easy installation.

##### (2) Interchangeability

Because of precision dimensional control, the dimensional tolerance of HG series can be kept in a reasonable range, which means that any blocks and any rails in a specific series can be used together while maintaining dimensional tolerance. And a retainer is added to prevent the balls from falling out when the blocks are removed from the rail.

##### (3) High rigidity in all four directions

Because of the four-row design, the HG series linear guideway has equal load ratings in the radial, reverse radial and lateral directions. Furthermore, the circular-arc groove provides a wide-contact width between the balls and the groove raceway allowing large permissible loads and high rigidity.

#### 2-1-2 Construction of HG Series

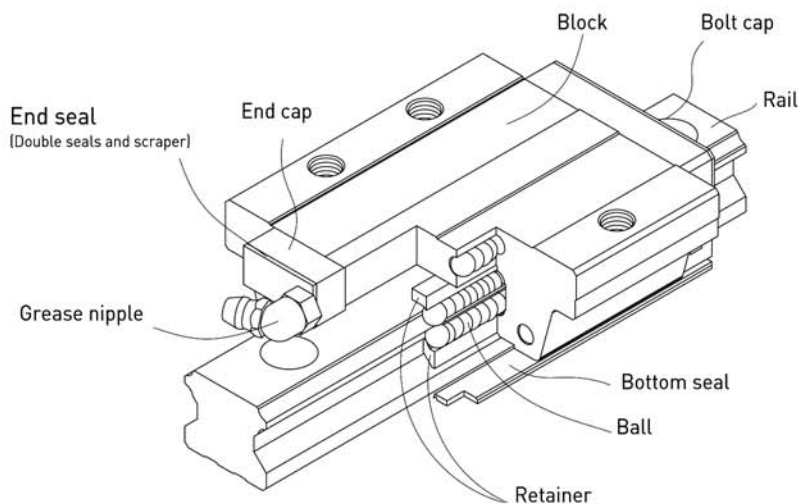

- Rolling circulation system: Block, Rail, End Cap and Retainer
- Lubrication system: Grease Nipple and Piping Joint
- Dust protection system: End seal, Bottom Seal, Bolt Cap, Double Seals and Scraper

#### 2-1-3 Model Number of HG Series

HG series guideways can be classified into non-interchangeable and interchangeable types. The sizes are identical. The only difference between the two types is that the interchangeable type of blocks and rails can be freely exchanged, and their accuracy can reach up to P class. The model number of HG series contains the size, type, accuracy class, preload class, etc..

(1) Non-interchangeable type

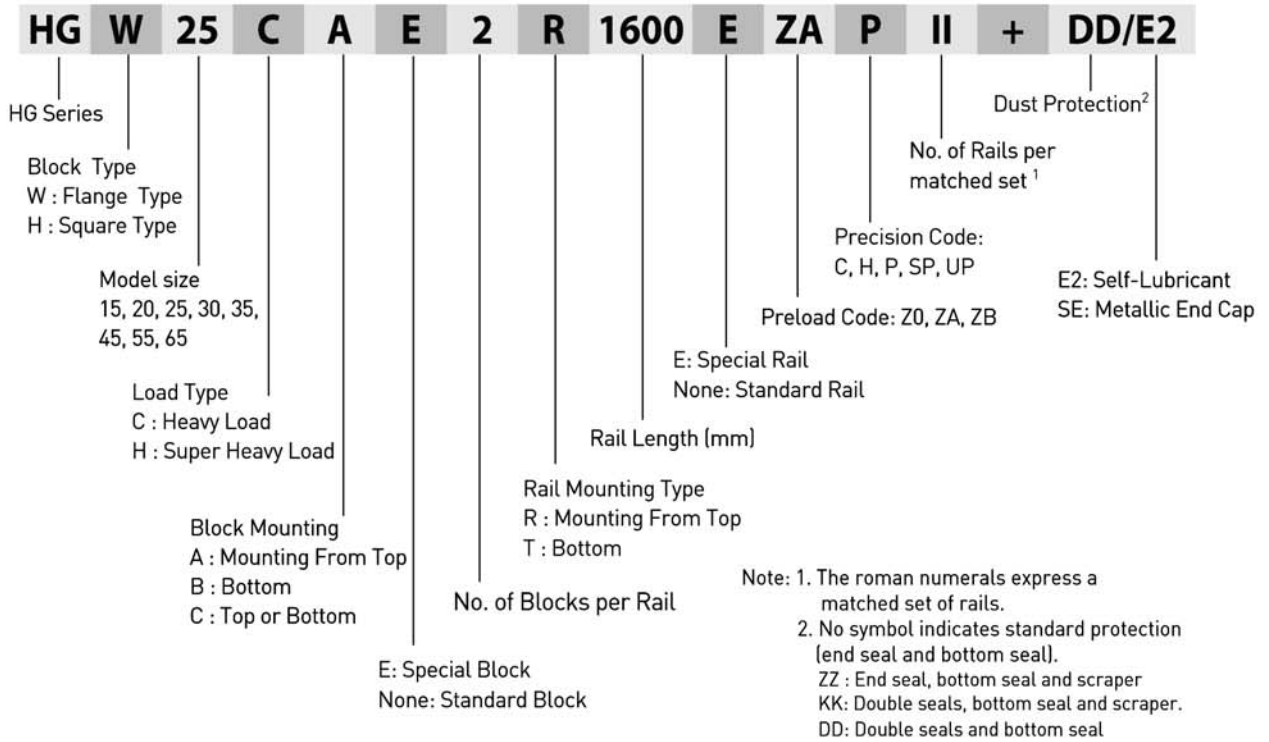

(2) Interchangeable type

○ Model Number of HG Block

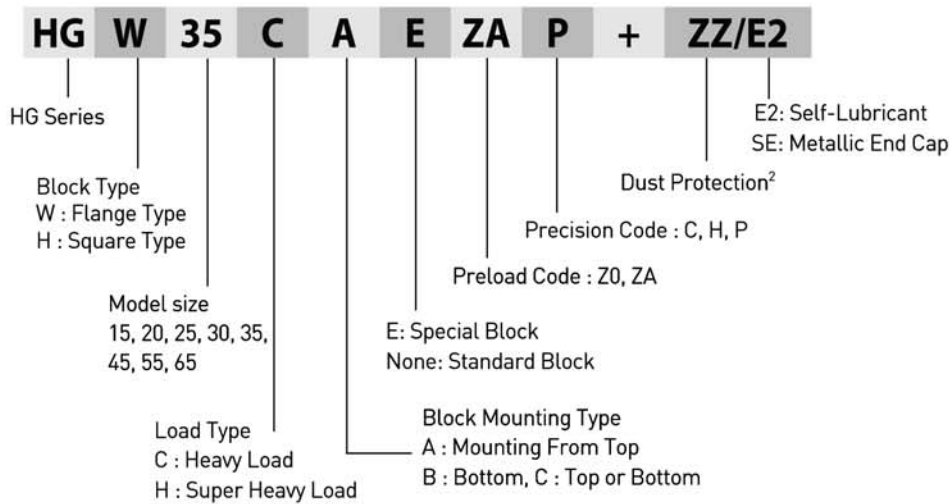

○ Model Number of HG Rail

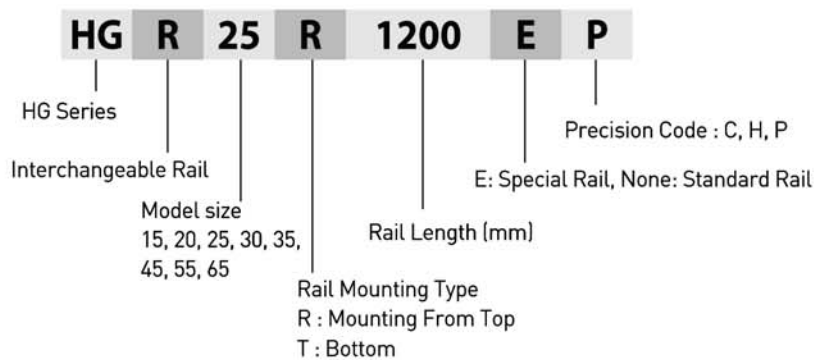

# Linear Guideways

## HG Series

### 2-1-4 Types

#### (1) Block types

HIWIN offers two types of linear guideway which are flange and square types. Because of the low assembly height and larger mounting surface, the flange type is suitable for heavy moment load application.

**Table 2.4 Block Types**

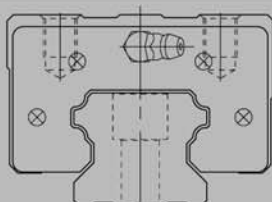
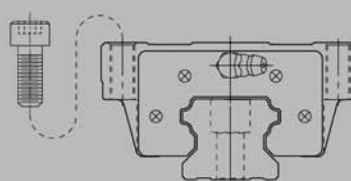
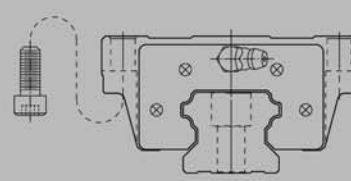
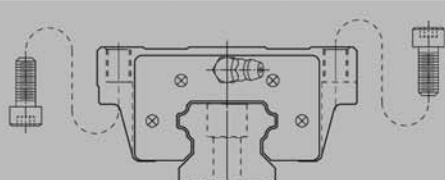
Type	Model	Shape	Height (mm)	Rail Length (mm)	Main Application
Square	HGH-CA		28	100	<ul style="list-style-type: none"> <li>○ Machine Centers</li> <li>○ NC Lathes</li> <li>○ Grinding Machines</li> <li>○ Precision Machining Machines</li> <li>○ Heavy Cutting Machines</li> <li>○ Automation Devices</li> <li>○ Transportation Equipment</li> <li>○ Measuring Equipment</li> <li>○ Devices Requiring High Positional Accuracy</li> </ul>
	HGH-HA		↓	↓	
Flange	HGW-CA		24	100	
	HGW-HA		↓	↓	
	HGW-CB		24	100	
	HGW-HB		↓	↓	
	HGW-CC		24	100	
	HGW-HC		↓	↓	
		90	4000		

#### (2) Rail types

Besides the standard top mounting type, HIWIN also offers the bottom mounting type of rails to customers.

**Table 2.5 Rail Types**

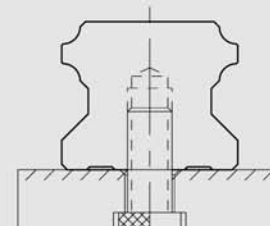
Mounting from Top	Mounting from bottom
	

## 2-1-5 Accuracy Classes

The accuracy of HG series can be classified into normal (C), high (H), precision (P), super precision (SP), ultra precision (UP), five classes. Please choose the class by referring the accuracy of applied equipment.

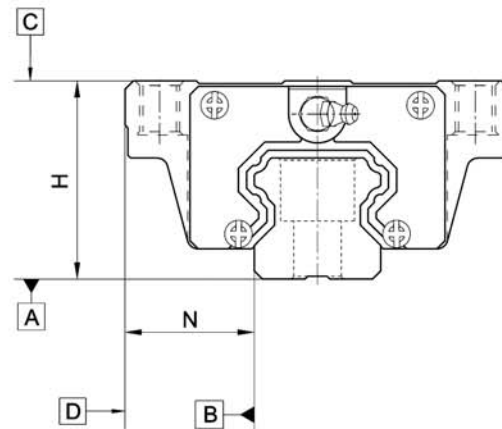

### (1) Accuracy of non-interchangeable

Table 2.6 Accuracy Standards

Unit: mm

Item	HG - 15, 20				
	Normal (C)	High (H)	Precision (P)	Super Precision (SP)	Ultra Precision (UP)
Dimensional tolerance of height H	± 0.1	± 0.03	0 - 0.03	0 - 0.015	0 - 0.008
Dimensional tolerance of width N	± 0.1	± 0.03	0 - 0.03	0 - 0.015	0 - 0.008
Variation of height H	0.02	0.01	0.006	0.004	0.003
Variation of width N	0.02	0.01	0.006	0.004	0.003
Running parallelism of block surface C to surface A	See Table 2.14				
Running parallelism of block surface D to surface B	See Table 2.14				

Table 2.7 Accuracy Standards

Unit: mm

Item	HG - 25, 30, 35				
	Normal (C)	High (H)	Precision (P)	Super Precision (SP)	Ultra Precision (UP)
Dimensional tolerance of height H	± 0.1	± 0.04	0 - 0.04	0 - 0.02	0 - 0.01
Dimensional tolerance of width N	± 0.1	± 0.04	0 - 0.04	0 - 0.02	0 - 0.01
Variation of height H	0.02	0.015	0.007	0.005	0.003
Variation of width N	0.03	0.015	0.007	0.005	0.003
Running parallelism of block surface C to surface A	See Table 2.14				
Running parallelism of block surface D to surface B	See Table 2.14				

# Linear Guideways

## HG Series

Table 2.8 Accuracy Standards

Unit: mm

Item	HG - 45, 55				
	Normal (C)	High (H)	Precision (P)	Super Precision (SP)	Ultra Precision (UP)
Dimensional tolerance of height H	± 0.1	± 0.05	0 - 0.05	0 - 0.03	0 - 0.02
Dimensional tolerance of width N	± 0.1	± 0.05	0 - 0.05	0 - 0.03	0 - 0.02
Variation of height H	0.03	0.015	0.007	0.005	0.003
Variation of width N	0.03	0.02	0.01	0.007	0.005
Running parallelism of block surface C to surface A	See Table 2.14				
Running parallelism of block surface D to surface B	See Table 2.14				

Table 2.9 Accuracy Standards

Unit: mm

Item	HG - 65				
	Normal (C)	High (H)	Precision (P)	Super Precision (SP)	Ultra Precision (UP)
Dimensional tolerance of height H	± 0.1	± 0.07	0 - 0.07	0 - 0.05	0 - 0.03
Dimensional tolerance of width N	± 0.1	± 0.07	0 - 0.07	0 - 0.05	0 - 0.03
Variation of height H	0.03	0.02	0.01	0.007	0.005
Variation of width N	0.03	0.025	0.015	0.01	0.007
Running parallelism of block surface C to surface A	See Table 2.14				
Running parallelism of block surface D to surface B	See Table 2.14				

### (2) Accuracy of interchangeable

Table 2.10 Accuracy Standards

Unit: mm

Item	HG - 15, 20		
	Normal (C)	High (H)	Precision (P)
Dimensional tolerance of height H	± 0.1	± 0.03	± 0.015
Dimensional tolerance of width N	± 0.1	± 0.03	± 0.015
Variation of height H	0.02	0.01	0.006
Variation of width N	0.02	0.01	0.006
Running parallelism of block surface C to surface A	See Table 2.14		
Running parallelism of block surface D to surface B	See Table 2.14		

Table 2.11 Accuracy Standards

Unit: mm

Item	HG - 25, 30, 35		
	Normal (C)	High (H)	Precision (P)
Dimensional tolerance of height H	± 0.1	± 0.04	± 0.02
Dimensional tolerance of width N	± 0.1	± 0.04	± 0.02
Variation of height H	0.02	0.015	0.007
Variation of width N	0.03	0.015	0.007
Running parallelism of block surface C to surface A	See Table 2.14		
Running parallelism of block surface D to surface B	See Table 2.14		



**Table 2.12 Accuracy Standards**

Unit: mm

Item	HG - 45, 55		
	Normal (C)	High (H)	Precision (P)
Dimensional tolerance of height H	± 0.1	± 0.05	± 0.025
Dimensional tolerance of width N	± 0.1	± 0.05	± 0.025
Variation of height H	0.03	0.015	0.007
Variation of width N	0.03	0.02	0.01
Running parallelism of block surface C to surface A	See Table 2.14		
Running parallelism of block surface D to surface B	See Table 2.14		

**Table 2.13 Accuracy Standards**

Unit: mm

Item	HG - 65		
	Normal (C)	High (H)	Precision (P)
Dimensional tolerance of height H	± 0.1	± 0.07	± 0.035
Dimensional tolerance of width N	± 0.1	± 0.07	± 0.035
Variation of height H	0.03	0.02	0.01
Variation of width N	0.03	0.025	0.015
Running parallelism of block surface C to surface A	See Table 2.14		
Running parallelism of block surface D to surface B	See Table 2.14		

### (3) Accuracy of running parallelism

**Table 2.14 Accuracy of Running Parallelism**

Rail Length (mm)	Accuracy (µm)				
	C	H	P	SP	UP
~ 100	12	7	3	2	2
100 ~ 200	14	9	4	2	2
200 ~ 300	15	10	5	3	2
300 ~ 500	17	12	6	3	2
500 ~ 700	20	13	7	4	2
700 ~ 900	22	15	8	5	3
900 ~ 1,100	24	16	9	6	3
1,100 ~ 1,500	26	18	11	7	4
1,500 ~ 1,900	28	20	13	8	4
1,900 ~ 2,500	31	22	15	10	5
2,500 ~ 3,100	33	25	18	11	6
3,100 ~ 3,600	36	27	20	14	7
3,600 ~ 4,000	37	28	21	15	7

# Linear Guideways

## HG Series

### 2-1-6 Preload

#### (1) Definition

A preload can be applied to each guideway. Oversized balls are used. Generally, a linear motion guideway has a negative clearance between groove and balls in order to improve stiffness and maintain high precision. The figure shows the load is multiplied by the preload, the rigidity is doubled and the deflection is reduced by one half. The preload not larger than ZA would be recommended for the model size under HG20 to avoid an over-preload affecting the guideway's life.

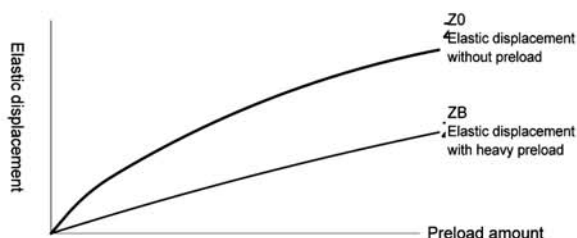

#### (2) Preload classes

HIWIN offers three classes of standard preload for various applications and conditions.

**Table 2.15 Preload Classes**

Class	Code	Preload	Condition	Examples of Application
Light Preload	Z0	0~0.02C	Certain load direction, low impact, low precision required	Transportation devices, auto-packing machines, X-Y axis for general industrial machines, welding machines, welders
Medium Preload	ZA	0.05~0.07C	High precision required	Machining centers, Z axis for general industrial machines, EDM, NC lathes, Precision X-Y tables, measuring equipment
Heavy Preload	ZB	0.10C~0.12C	High rigidity required, with vibration and impact	Machining centers, grinding machines, NC lathes, horizontal and vertical milling machines, Z axis of machine tools, Heavy cutting machines

Note : 1. The C in preload column means basic dynamic load rating.

2. Preload Classes of Interchangeable Guideway: Z0, ZA.

Preload Classes of Non-Interchangeable Guideway: Z0, ZA, ZB

## 2-1-7 Lubrication

### (1) Grease

#### ○ Grease nipple

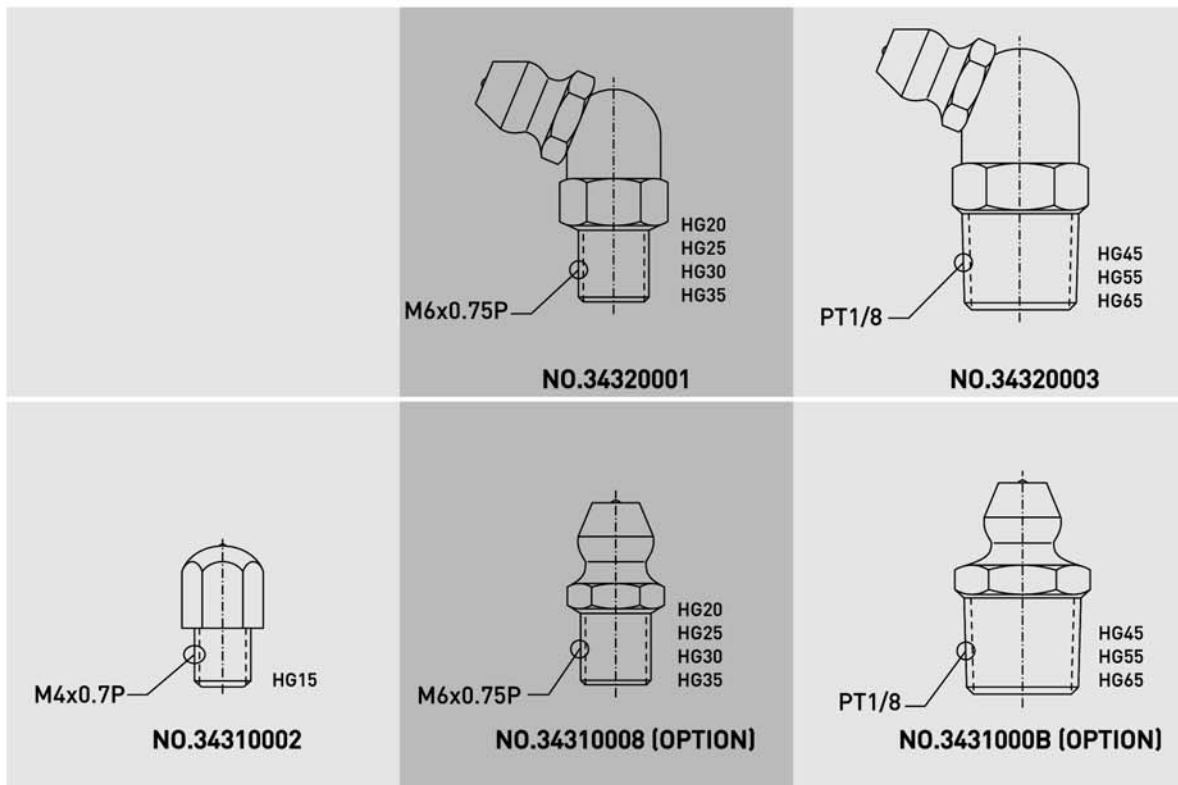

#### ○ Mounting location

The standard location of the grease fitting is at both ends of the block, but the nipple can be mounted at each side of block. For lateral installation, we recommend that the nipple be mounted at the non-reference side, otherwise please contact us. It is possible to perform lubrication by using the oil-piping joint.

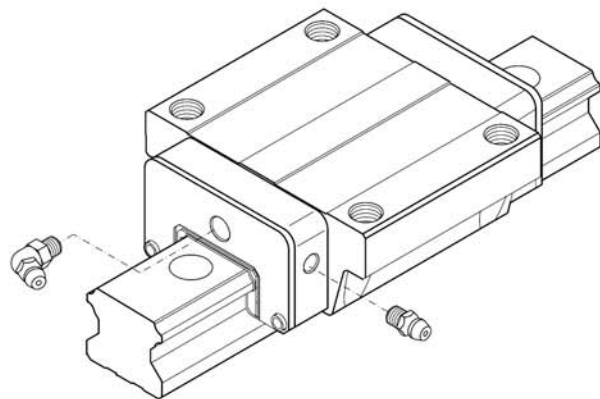

#### ○ The lubricant amount for a block filled with grease

Table 2.16 The lubricant Amount for a Block Filled with Grease

Size	Heavy load (cm <sup>3</sup> )	Super heavy load (cm <sup>3</sup> )	Size	Heavy load (cm <sup>3</sup> )	Super heavy load (cm <sup>3</sup> )
HG 15	1	-	HG 35	10	12
HG 20	2	3	HG 45	17	21
HG 25	5	6	HG 55	26	33
HG 30	7	8	HG 65	50	61

#### ○ Frequency of replenishment

Check the grease every 100 km, or every 3-6 months.

# Linear Guideways

## HG Series

### (2) Oil

The recommended viscosity of oil is about 30–150cSt. If customers need to use oil-type lubrication, please inform us, and the block will not be prelubricated with grease before shipment.

### ○ Types of oil piping joint

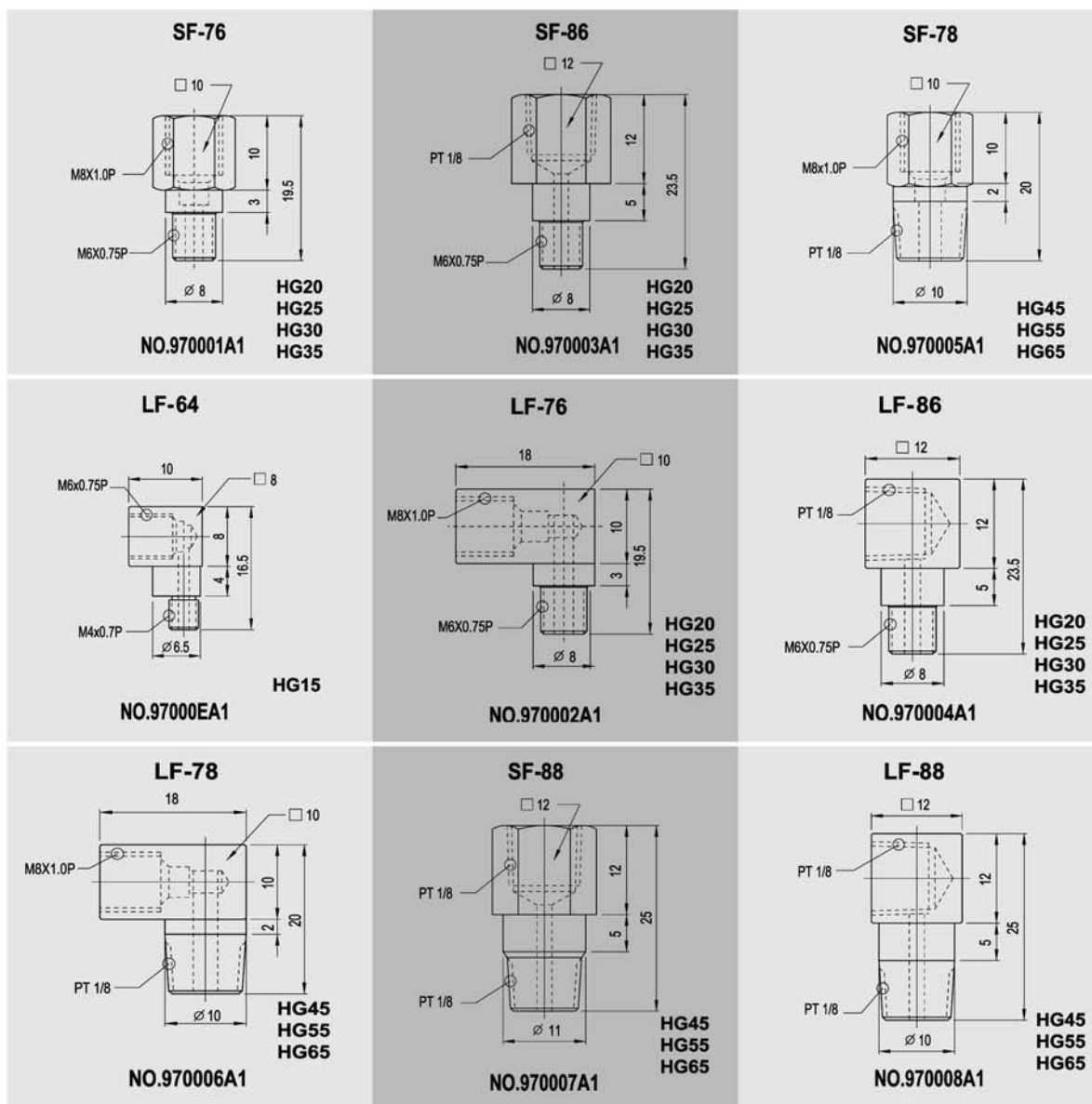

### ○ Oil refilling rate

Table 2.17

Size	Refilling rate (cm <sup>3</sup> /hr)	Size	Refilling rate (cm <sup>3</sup> /hr)
HG 15	0.2	HG 35	0.3
HG 20	0.2	HG 45	0.4
HG 25	0.3	HG 55	0.5
HG 30	0.3	HG 65	0.6

## 2-1-8 Dust Proof Accessories

### (1) Codes of accessories

If the following accessories are needed, please add the code followed by the model number.

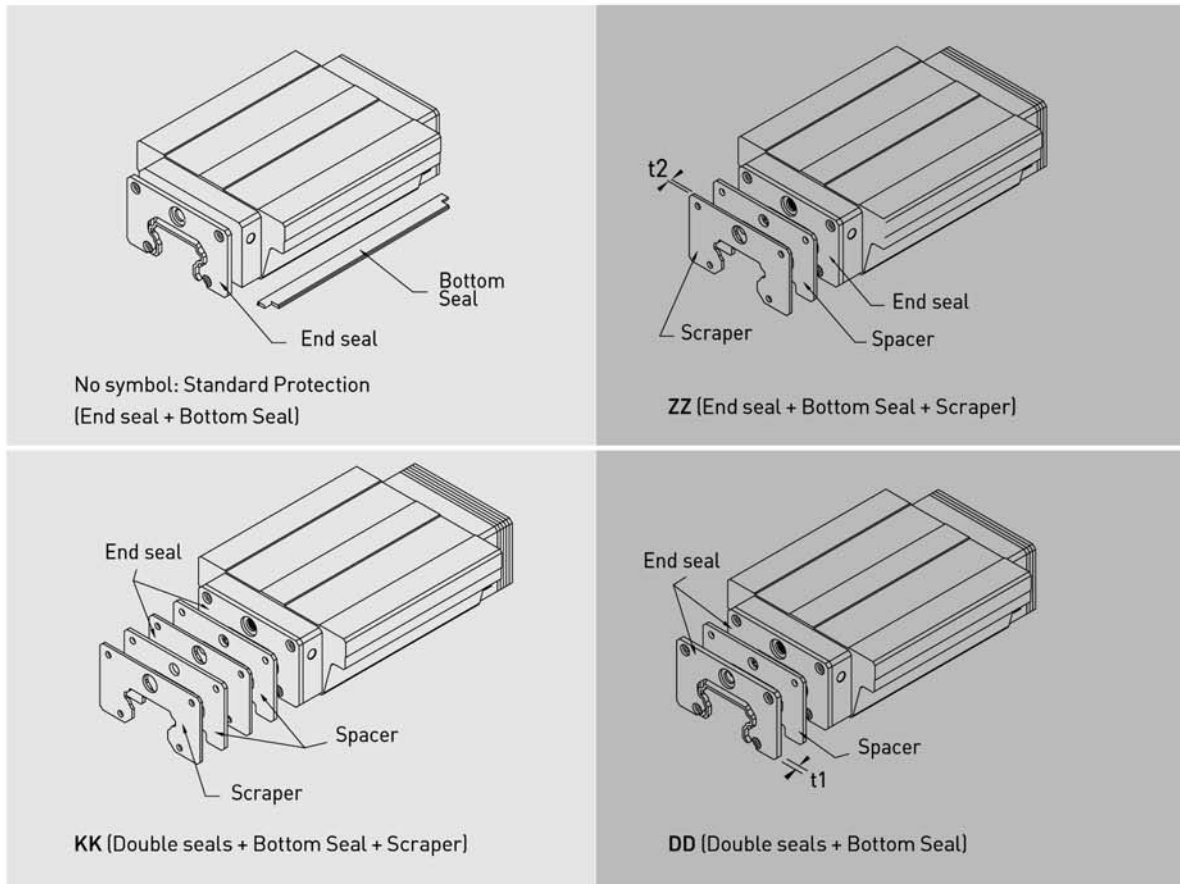

### (2) End seal and bottom seal

To prevent life reduction caused by iron chips or dust entering the block.

### (3) Double seals

Enhances the wiping effect, foreign matter can be completely wiped off.

**Table 2.18 Dimensions of end seal**

Size	Thickness (t1) (mm)	Size	Thickness (t1) (mm)
HG 15 ES	3	HG 35 ES	3.2
HG 20 ES	3	HG 45 ES	4.5
HG 25 ES	3	HG 55 ES	5
HG 30 ES	3.2	HG 65 ES	5

### (4) Scraper

The scraper removes high-temperature iron chips and larger foreign objects.

**Table 2.19 Dimensions of scraper**

Size	Thickness (t2) (mm)	Size	Thickness (t2) (mm)
HG 15 SC	1.5	HG 35 SC	1.5
HG 20 SC	1.5	HG 45 SC	1.5
HG 25 SC	1.5	HG 55 SC	1.7
HG 30 SC	1.5	HG 65 SC	1.7

# Linear Guideways

## HG Series

### (5) Bolt caps for rail mounting holes

Caps are used to cover the mounting holes to prevent chips or other foreign objects from collecting in the holes. The caps will be enclosed in each rail package.

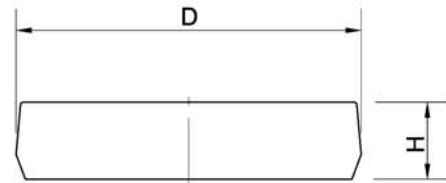

**Table 2.20 Dimensions of Bolt Caps for Rail Mounting Holes**

Rail size	Bolt size	Diameter(D) (mm)	Thickness(H) (mm)	Rail size	Bolt size	Diameter(D) (mm)	Thickness(H) (mm)
HGR15	M4	7.7	1.1	HGR35	M8	14.3	3.3
HGR20	M5	9.7	2.2	HGR45	M12	20.3	4.6
HGR25	M6	11.3	2.5	HGR55	M14	23.5	5.5
HGR30	M8	14.3	3.3	HGR65	M16	26.6	5.5

### 2-1-9 Friction

The maximum value of resistance per end seal are as shown in the table.

**Table 2.21 Seal Resistance**

Size	Resistance (kgf)	Size	Resistance (kgf)
HG15	0.12	HG35	0.31
HG20	0.16	HG45	0.39
HG25	0.2	HG55	0.47
HG30	0.27	HG65	0.59

### 2-1-10 The Accuracy Tolerance of Mounting Surface

#### (1) The accuracy tolerance of rail-mounting surface

Because of the Circular-arc contact design, the HG linear guideway can compensate for some surface-error on installation and still maintain smooth linear motion.

As long as the accuracy requirements for the mounting surface are followed, high accuracy and rigidity of linear motion of the guideway can be obtained without any difficulty. In order to satisfy the needs of fast installation and smooth movement, HIWIN offers the normal clearance type of preload to customers of its high absorption ability of the deviation in mounting surface accuracy.

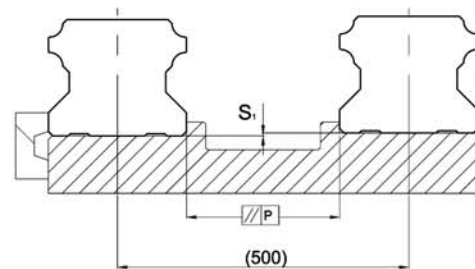

#### (2) The parallelism tolerance of reference surface (P)

**Table 2.22 Max. Parallelism Tolerance (P)**

unit:  $\mu\text{m}$

Size	Preload classes		
	Z0	ZA	ZB
HG15	25	18	-
HG20	25	20	18
HG25	30	22	20
HG30	40	30	27
HG35	50	35	30
HG45	60	40	35
HG55	70	50	45
HG65	80	60	55

### (3) The accuracy tolerance of reference surface height

Table 2.23 Max. Tolerance of Reference Surface Height (S<sub>1</sub>)

unit: μm

Size	Preload classes		
	Z0	ZA	ZB
HG15	130	85	-
HG20	130	85	50
HG25	130	85	70
HG30	170	110	90
HG35	210	150	120
HG45	250	170	140
HG55	300	210	170
HG65	350	250	200

## 2-1-11 Cautions for Installation

### (1) Shoulder heights and fillets

Improper shoulder heights and fillets of mounting surfaces will cause a deviation in accuracy and the interference with the chamfered part of the rail or block. As long as the recommended shoulder heights and fillets are followed, installation inaccuracies should be eliminated.

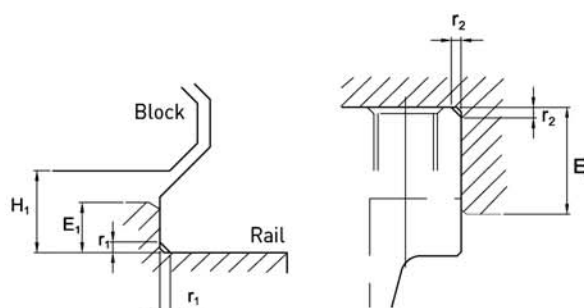

Table 2.24 Shoulder Heights and Fillets

Size	Max. radius of fillets	Max. radius of fillets	Shoulder height of the rail	Shoulder height of the block	Clearance under block
	r <sub>1</sub> (mm)	r <sub>2</sub> (mm)	E <sub>1</sub> (mm)	E <sub>2</sub> (mm)	H <sub>1</sub> (mm)
HG15	0.5	0.5	3	4	4.3
HG20	0.5	0.5	3.5	5	4.6
HG25	1.0	1	5	5	5.5
HG30	1.0	1	5	5	6
HG35	1.0	1	6	6	7.5
HG45	1.0	1	8	8	9.5
HG55	1.5	1.5	10	10	13
HG65	1.5	1.5	10	10	15

### (2) Tightening Torque of Bolts for Installation

Improper tightening of bolts will seriously influence the accuracy of Linear Guideway installation. The following tightening torques for different sizes of bolts are recommended.

Table 2.25 Mounting Torque

Size	Bolt size	Torque N-cm (kgf-cm)	Size	Bolt size	Torque N-cm (kgf-cm)
HG 15	M4 x 0.7P x 16L	392(40)	HG 35	M8 x 1.25P x 25L	3,041(310)
HG 20	M5 x 0.8P x 16L	883(90)	HG 45	M12 x 1.75P x 35L	11,772(1,200)
HG 25	M6 x 1P x 20L	1373(140)	HG 55	M14 x 2P x 45L	15,696(1,600)
HG 30	M8 x 1.25P x 25L	3041(310)	HG 65	M16 x 2P x 50L	19,620(2,000)

# Linear Guideways

## HG Series

### 2-1-12 Standard and Maximum Lengths of Rail

HIWIN offers standard rail lengths for customer needs. For non-standard E-values, the recommended dimension should not be greater than 1/2 of the pitch (P) dimension. This will prevent an unstable rail end.

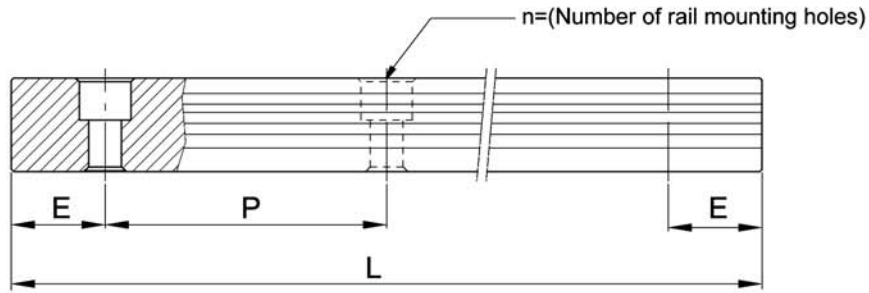

$$L = (n-1) \times P + 2 \times E \dots\dots\dots \text{Eq.2.1}$$

- L : Total length of rail (mm)
- n : Number of mounting holes
- P : Distance between any two holes (mm)
- E : Distance from the center of the last hole to the edge (mm)

**Table 2.26 Rail Standard Length and Max. Length**

unit: mm

Item	HG15	HG20	HG25	HG30	HG35	HG45	HG55	HG65
Standard Length L(n)	160(3)	220(4)	220(4)	280(4)	280(4)	570(6)	780(7)	1,270(9)
	220(4)	280(5)	280(5)	440(6)	440(6)	885(9)	1,020(9)	1,570(11)
	280(5)	340(6)	340(6)	600(8)	600(8)	1,200(12)	1,260(11)	2,020(14)
	340(6)	460(8)	460(8)	760(10)	760(10)	1,620(16)	1,500(13)	2,620(18)
	460(8)	640(11)	640(11)	1,000(13)	1,000(13)	2,040(20)	1,980(17)	
	640(11)	820(14)	820(14)	1,640(21)	1,640(21)	2,460(24)	2,580(22)	
	820(14)	1,000(17)	1,000(17)	2,040(26)	2,040(26)	2,985(29)	2,940(25)	
		1,240(21)	1,240(21)	2,520(32)	2,520(32)			
		1,600(27)	3,000(38)	3,000(38)				
Pitch (P)	60	60	60	80	80	105	120	150
Distance to End (E <sub>c</sub> )	20	20	20	20	20	22.5	30	35
Max. Standard Length	1,960(33)	4,000(67)	4,000(67)	3,960(50)	3,960(50)	3,930(38)	3,900(33)	3,970(27)
Max. Length	2,000	4,000	4,000	4,000	4,000	4,000	4,000	4,000

- Note :
1. Tolerance of E value for standard rail is 0.5--0.5 mm. Tolerance of E value for jointed rail is 0--0.3 mm.
  2. Maximum standard length means the max. rail length with standard E value on both sides.
  3. If different E value is needed, please contact HIWIN.



## 2-1-13 Dimensions for HIWIN HG Series

### (1) HGH-CA / HGH-HA

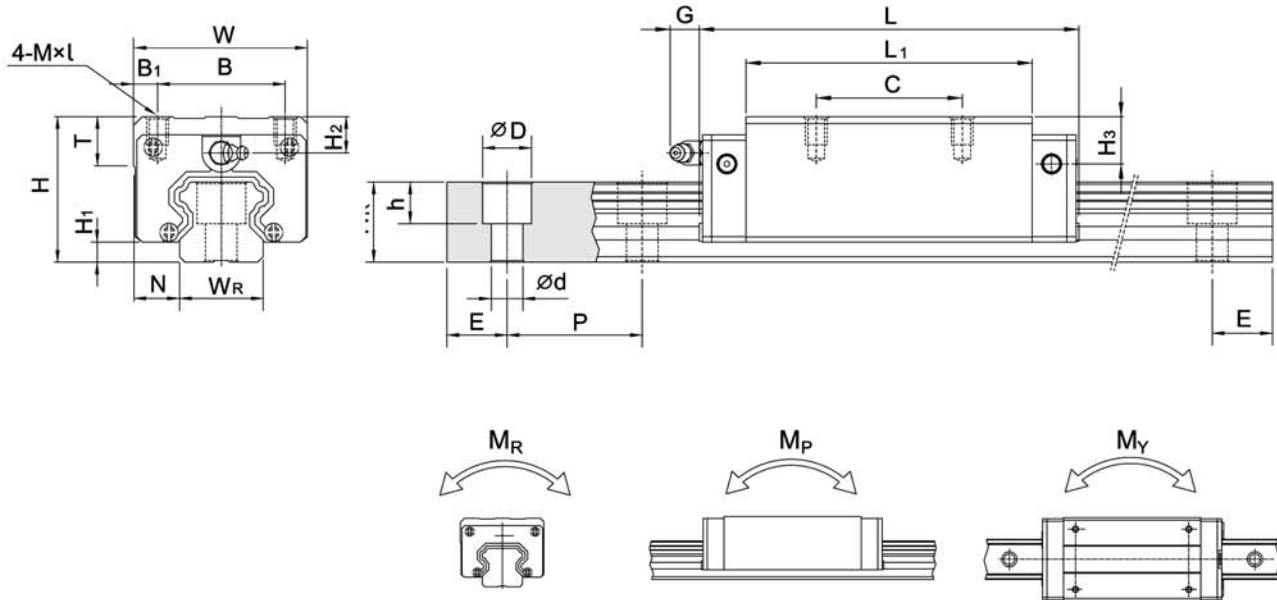

Model No.	Dimensions of Assembly (mm)			Dimensions of Block (mm)										Dimensions of Rail (mm)						Mounting Bolt for Rail (mm)	Basic Dynamic Load Rating C(kN)	Basic Static Load Rating C <sub>0</sub> (kN)	Static Rated Moment			Weight			
	H	H <sub>1</sub>	N	W	B	B <sub>1</sub>	C	L <sub>1</sub>	L	G	Mxl	T	H <sub>2</sub>	H <sub>3</sub>	W <sub>R</sub>	H <sub>R</sub>	D	h	d				P	E	M <sub>R</sub> (kN-m)	M <sub>P</sub> (kN-m)	M <sub>Y</sub> (kN-m)	Block (kg)	Rail (kg/m)
HGH 15CA	28	4.3	9.5	34	26	4	26	39.4	61.4	5.3	M4x5	6	8.5	9.5	15	15	7.5	5.3	4.5	60	20	M4x16	11.38	25.31	0.17	0.15	0.15	0.18	1.45
HGH 20CA	30	4.6	12	44	32	6	36	50.5	77.5	12	M5x6	8	6	7	20	17.5	9.5	8.5	6	60	20	M5x16	17.75	37.84	0.38	0.27	0.27	0.30	2.21
HGH 20HA							50	65.2	92.2														21.18	48.84	0.48	0.47	0.47	0.39	
HGH 25CA	40	5.5	12.5	48	35	6.5	35	58	84	12	M6x8	8	10	13	23	22	11	9	7	60	20	M6x20	26.48	56.19	0.64	0.51	0.51	0.51	3.21
HGH 25HA							50	78.6	104.6														32.75	76.00	0.87	0.88	0.88	0.69	
HGH 30CA	45	6	16	60	40	10	40	70	97.4	12	M8x10	8.5	9.5	13.8	28	26	14	12	9	80	20	M8x25	38.74	83.06	1.06	0.85	0.85	0.88	4.47
HGH 30HA							60	93	120.4														47.27	110.13	1.40	1.47	1.47	1.16	
HGH 35CA	55	7.5	18	70	50	10	50	80	112.4	12	M8x12	10.2	16	19.6	34	29	14	12	9	80	20	M8x25	49.52	102.87	1.73	1.20	1.20	1.45	6.30
HGH 35HA							72	105.8	138.2														60.21	136.31	2.29	2.08	2.08	1.92	
HGH 45CA	70	9.5	20.5	86	60	13	60	97	139.4	12.9	M10x17	16	18.5	30.5	45	38	20	17	14	105	22.5	M12x35	77.57	155.93	3.01	2.35	2.35	2.73	10.41
HGH 45HA							80	128.8	171.2														94.54	207.12	4.00	4.07	4.07	3.61	
HGH 55CA	80	13	23.5	100	75	12.5	75	117.7	166.7	12.9	M12x18	17.5	22	29	53	44	23	20	16	120	30	M14x45	114.44	227.81	5.66	4.06	4.06	4.17	15.08
HGH 55HA							95	155.8	204.8														139.35	301.26	7.49	7.01	7.01	5.49	
HGH 65CA	90	15	31.5	126	76	25	70	144.2	200.2	12.9	M16x20	25	15	15	63	53	26	22	18	150	35	M16x50	163.63	324.71	10.02	6.44	6.44	7.00	21.18
HGH 65HA							120	203.6	259.6														208.36	457.15	14.15	11.12	11.12	9.82	

Note : 1 kgf = 9.81 N

# Linear Guideways

## HG Series

### (2) HGW-CA / HGW-HA

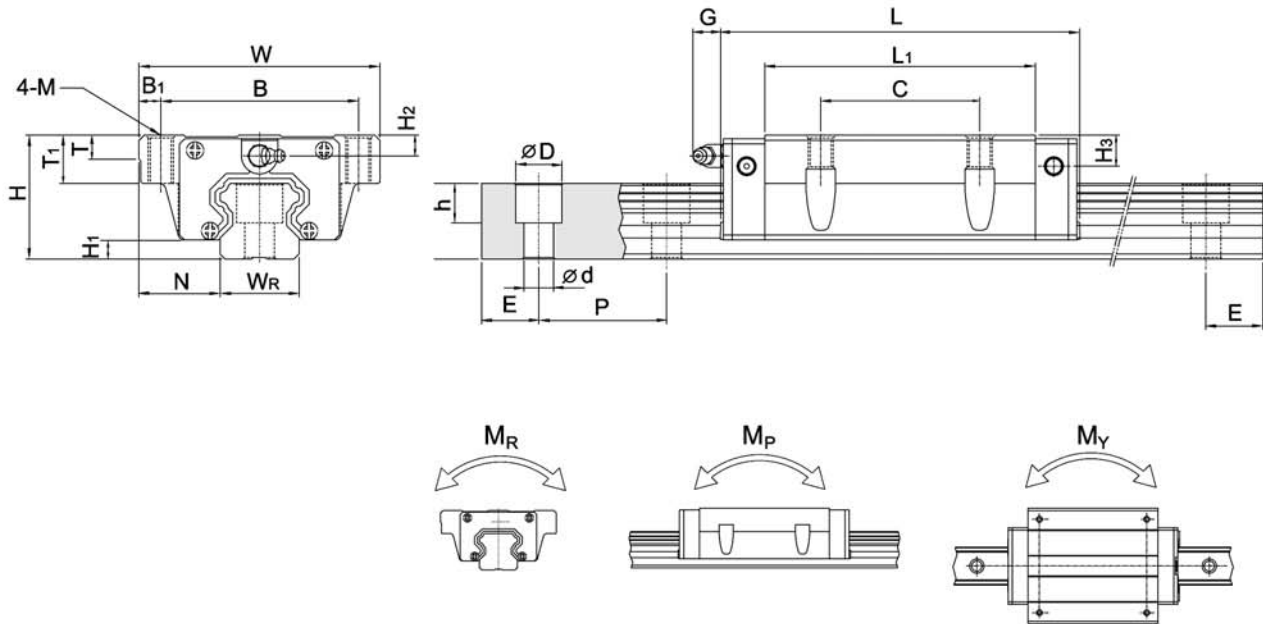

Model No.	Dimensions of Assembly (mm)		Dimensions of Block (mm)													Dimensions of Rail (mm)						Mounting Bolt for Rail (mm)	Basic Dynamic Load Rating C(kN)	Basic Static Load Rating Co (kN)	Static Rated Moment			Weight		
	H	H <sub>1</sub>	N	W	B	B <sub>1</sub>	C	L <sub>1</sub>	L	G	M	T	T <sub>1</sub>	H <sub>2</sub>	H <sub>3</sub>	W <sub>R</sub>	H <sub>R</sub>	D	h	d	P				E	M <sub>R</sub> (kN-m)	M <sub>P</sub> (kN-m)	M <sub>Y</sub> (kN-m)	Block (kg)	Rail (kg/m)
	HGW 15CA	24	4.3	16	47	38	4.5	30	39.4	61.4	5.3	M5	6	8.9	4.5	5.5	15	15	7.5	5.3	4.5	60	20	M4x16	11.38	25.31	0.17	0.15	0.15	0.17
HGW 20CA	30	4.6	21.5	63	53	5	40	50.5	77.5	12	M6	8	10	6	7	20	17.5	9.5	8.5	6	60	20	M5x16	17.75	37.84	0.38	0.27	0.27	0.40	2.21
HGW 20HA								65.2	92.2															21.18	48.84	0.48	0.47	0.47	0.52	
HGW 25CA	36	5.5	23.5	70	57	6.5	45	58	84	12	M8	8	14	6	9	23	22	11	9	7	60	20	M6x20	26.48	56.19	0.64	0.51	0.51	0.59	3.21
HGW 25HA								78.6	104.6															32.75	76.00	0.87	0.88	0.88	0.80	
HGW 30CA	42	6	31	90	72	9	52	70	97.4	12	M10	8.5	16	6.5	10.8	28	26	14	12	9	80	20	M8x25	38.74	83.06	1.06	0.85	0.85	1.09	4.47
HGW 30HA								93	120.4															47.27	110.13	1.40	1.47	1.47	1.44	
HGW 35CA	48	7.5	33	100	82	9	62	80	112.4	12	M10	10.1	18	9	12.6	34	29	14	12	9	80	20	M8x25	49.52	102.87	1.73	1.20	1.20	1.56	6.30
HGW 35HA								105.8	138.2															60.21	136.31	2.29	2.08	2.08	2.06	
HGW 45CA	60	9.5	37.5	120	100	10	80	97	139.4	12.9	M12	15.1	22	8.5	20.5	45	38	20	17	14	105	22.5	M12x35	77.57	155.93	3.01	2.35	2.35	2.79	10.41
HGW 45HA								128.8	171.2															94.54	207.12	4.00	4.07	4.07	3.69	
HGW 55CA	70	13	43.5	140	116	12	95	117.7	166.7	12.9	M14	17.5	26.5	12	19	53	44	23	20	16	120	30	M14x45	114.44	227.81	5.66	4.06	4.06	4.52	15.08
HGW 55HA								155.8	204.8															139.35	301.26	7.49	7.01	7.01	5.96	
HGW 65CA	90	15	53.5	170	142	14	110	144.2	200.2	12.9	M16	25	37.5	15	15	63	53	26	22	18	150	35	M16x50	163.63	324.71	10.02	6.44	6.44	9.17	21.18
HGW 65HA								203.6	259.6															208.36	457.15	14.15	11.12	11.12	12.89	

Note : 1 kgf = 9.81 N

### (3) HGW-CB / HGW-HB

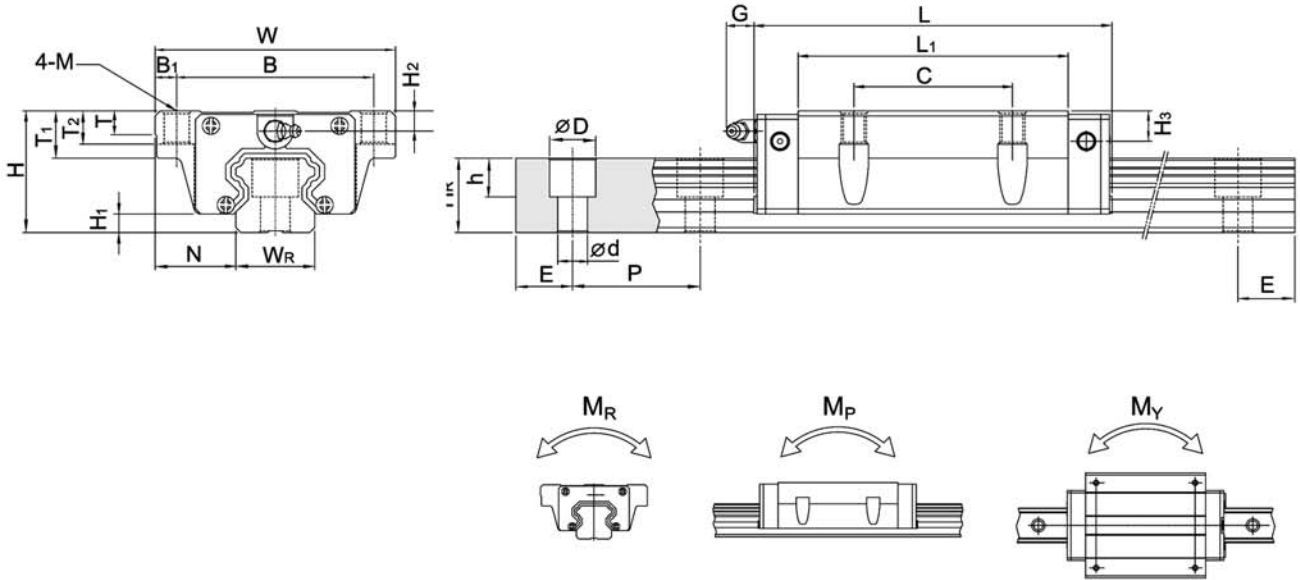

Model No.	Dimensions of Assembly (mm)			Dimensions of Block (mm)											Dimensions of Rail (mm)						Mounting Bolt for Rail (mm)	Basic Dynamic Load Rating C(kN)	Basic Static Load Rating C <sub>0</sub> (kN)	Static Rated Moment			Weight				
	H	H <sub>1</sub>	N	W	B	B <sub>1</sub>	C	L <sub>1</sub>	L	G	M	T	T <sub>1</sub>	T <sub>2</sub>	H <sub>2</sub>	H <sub>3</sub>	W <sub>R</sub>	H <sub>R</sub>	D	h				d	P	E	M <sub>R</sub>	M <sub>P</sub>	M <sub>Y</sub>	Block	Rail
	kg	mm	mm	mm	mm	mm	mm	mm	mm	mm	mm	mm	mm	mm	mm	mm	mm	mm	mm	mm				mm	mm	mm	mm	kN-m	kN-m	kN-m	kg
HGW 15CB	24	4.3	16	47	38	4.5	30	39.4	61.4	5.3	Ø4.5	6	8.9	6.95	4.5	5.5	15	15	7.5	5.3	4.5	60	20	M4x16	11.38	25.31	0.17	0.15	0.15	0.17	1.45
HGW 20CB	30	4.6	21.5	63	53	5	40	50.5	77.5	12	Ø6	8	10	9.5	6	7	20	17.5	9.5	8.5	6	60	20	M5x16	17.75	37.84	0.38	0.27	0.27	0.40	2.21
HGW 20HB								65.2	92.2																21.18	48.84	0.48	0.47	0.47	0.52	
HGW 25CB	36	5.5	23.5	70	57	6.5	45	58	84	12	Ø7	8	14	10	6	9	23	22	11	9	7	60	20	M6x20	26.48	56.19	0.64	0.51	0.51	0.59	3.21
HGW 25HB								78.6	104.6																32.75	76.00	0.87	0.88	0.88	0.80	
HGW 30CB	42	6	31	90	72	9	52	70	97.4	12	Ø9	8.5	16	10	6.5	10.8	28	26	14	12	9	80	20	M8x25	38.74	83.06	1.06	0.85	0.85	1.09	4.47
HGW 30HB								93	120.4																47.27	110.13	1.40	1.47	1.47	1.44	
HGW 35CB	48	7.5	33	100	82	9	62	80	112.4	12	Ø9	10.1	18	13	9	12.6	34	29	14	12	9	80	20	M8x25	49.52	102.87	1.73	1.20	1.20	1.56	6.30
HGW 35HB								105.8	138.2																60.21	136.31	2.29	2.08	2.08	2.06	
HGW 45CB	60	9.5	37.5	120	100	10	80	97	139.4	12.9	Ø11	15.1	22	15	8.5	20.5	45	38	20	17	14	105	22.5	M12x35	77.57	155.93	3.01	2.35	2.35	2.79	10.41
HGW 45HB								128.8	171.2																94.54	207.12	4.00	4.07	4.07	3.69	
HGW 55CB	70	13	43.5	140	116	12	95	117.7	166.7	12.9	Ø14	17.5	26.5	17	12	19	53	44	23	20	16	120	30	M14x45	114.44	227.81	5.66	4.06	4.06	4.52	15.08
HGW 55HB								155.8	204.8																139.35	301.26	7.49	7.01	7.01	5.96	
HGW 65CB	90	15	53.5	170	142	14	110	144.2	200.2	12.9	Ø16	25	37.5	23	15	15	63	53	26	22	18	150	35	M16x50	163.63	324.71	10.02	6.44	6.44	9.17	21.18
HGW 65HB								203.6	259.6																208.36	457.15	14.15	11.12	11.12	12.89	

Note : 1 kgf = 9.81 N

# Linear Guideways

## HG Series

### (4) HGW-CC / HGW-HC

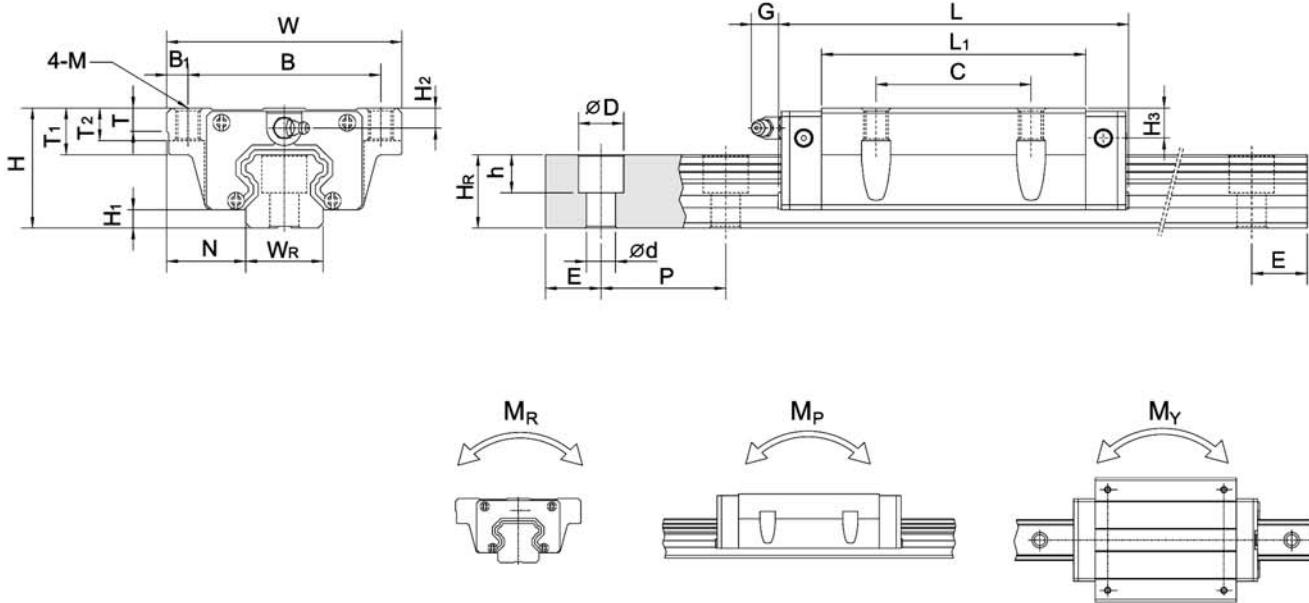

Model No.	Dimensions of Assembly (mm)		Dimensions of Block (mm)													Dimensions of Rail (mm)						Mounting Bolt for Rail (mm)	Basic Dynamic Load Rating C(kN)	Basic Static Load Rating C <sub>0</sub> (kN)	Static Rated Moment			Weight			
	H	H <sub>1</sub>	N	W	B	B <sub>1</sub>	C	L <sub>1</sub>	L	G	M	T	T <sub>1</sub>	T <sub>2</sub>	H <sub>2</sub>	H <sub>3</sub>	W <sub>R</sub>	H <sub>R</sub>	D	h	d				P	E	M <sub>R</sub> (kN-m)	M <sub>P</sub> (kN-m)	M <sub>Y</sub> (kN-m)	Block (kg)	Rail (kg/m)
HGW 15CC	24	4.3	16	47	38	4.5	30	39.4	61.4	5.3	M5	6	8.9	6.95	4.5	5.5	15	15	7.5	5.3	4.5	60	20	M4x16	11.38	25.31	0.17	0.15	0.15	0.17	1.45
HGW 20CC	30	4.6	21.5	63	53	5	40	50.5	77.5	12	M6	8	10	9.5	6	7	20	17.5	9.5	8.5	6	60	20	M5x16	17.75	37.84	0.38	0.27	0.27	0.40	2.21
HGW 20HC								65.2	92.2																21.18	48.84	0.48	0.47	0.47	0.52	
HGW 25CC	36	5.5	23.5	70	57	6.5	45	58	84	12	M8	8	14	10	6	9	23	22	11	9	7	60	20	M6x20	26.48	56.19	0.64	0.51	0.51	0.59	3.21
HGW 25HC								78.6	104.6																32.75	76.00	0.87	0.88	0.88	0.80	
HGW 30CC	42	6	31	90	72	9	52	70	97.4	12	M10	8.5	16	10	6.5	10.8	28	26	14	12	9	80	20	M8x25	38.74	83.06	1.06	0.85	0.85	1.09	4.47
HGW 30HC								93	120.4																47.27	110.13	1.40	1.47	1.47	1.44	
HGW 35CC	48	7.5	33	100	82	9	62	80	112.4	12	M10	10.1	18	13	9	12.6	34	29	14	12	9	80	20	M8x25	49.52	102.87	1.73	1.20	1.20	1.56	6.30
HGW 35HC								105.8	138.2																60.21	136.31	2.29	2.08	2.08	2.06	
HGW 45CC	60	9.5	37.5	120	100	10	80	97	139.4	12.9	M12	15.1	22	15	8.5	20.5	45	38	20	17	14	105	22.5	M12x35	77.57	155.93	3.01	2.35	2.35	2.79	10.41
HGW 45HC								128.8	171.2																94.54	207.12	4.00	4.07	4.07	3.69	
HGW 55CC	70	13	43.5	140	116	12	95	117.7	166.7	12.9	M14	17.5	26.5	17	12	19	53	44	23	20	16	120	30	M14x45	114.44	227.81	5.66	4.06	4.06	4.52	15.08
HGW 55HC								155.8	204.8																139.35	301.26	7.49	7.01	7.01	5.96	
HGW 65CC	90	15	53.5	170	142	14	110	144.2	200.2	12.9	M16	25	37.5	23	15	15	63	53	26	22	18	150	35	M16x50	163.63	324.71	10.02	6.44	6.44	9.17	21.18
HGW 65HC								203.6	259.6																208.36	457.15	14.15	11.12	11.12	12.89	

Note : 1 kgf = 9.81 N

## (5) Dimesions for HGR-T (Rail Mounting from Below)

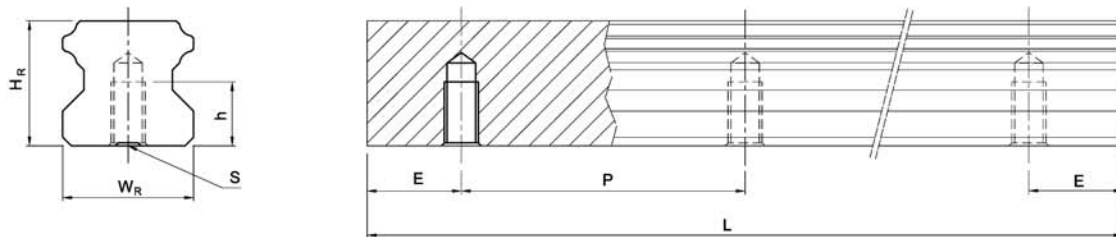

Model No.	Dimensions of Rail (mm)						Weight (kg/m)
	W <sub>R</sub>	H <sub>R</sub>	S	h	P	E	
HGR15T	15	15	M5 x 0.8P	8	60	20	1.48
HGR20T	20	17.5	M6 x 1P	10	60	20	2.29
HGR25T	23	22	M6 x 1P	12	60	20	3.35
HGR30T	28	26	M8 x 1.25P	15	80	20	4.67
HGR35T	34	29	M8x1.25P	17	80	20	6.51
HGR45T	45	38	M12 x 1.75P	24	105	22.5	10.87
HGR55T	53	44	M14 x 2P	24	120	30	15.67
HGR65T	63	53	M20 x 2.5P	30	150	35	21.73

# Linear Guideways

## EG Series

### 2-2 EG Series - Low Profile Ball Type Linear Guideway

#### 2-2-1 Features of the EG Series Linear Guideway

The design of the EG series offers a low profile, high load capacity, and high rigidity. It also features an equal load rating in all four directions and self-aligning capability to absorb installation-error, allowing for higher accuracies. Additionally, the lower assembly height and the shorter length make the EG series more suitable for high-speed, automation machines and applications where space is limited.

The retainer is designed to hold the balls in the block even when it is removed from the rail.

#### 2-2-2 Construction of EG Series

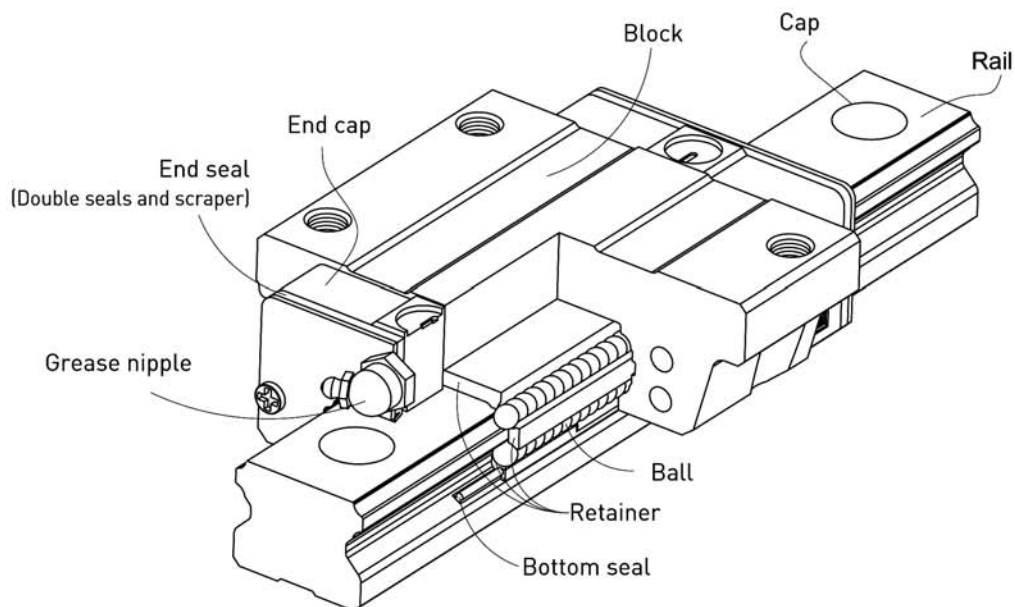

- Rolling circulation system: Block, rail, end cap and retainer
- Lubrication system: Grease nipple and piping Joint
- Dust protection system: End seal, bottom seal, cap and scraper

#### 2-2-3 Model Number of EG Series

EG series linear guideways are classified into non-interchangeable and interchangeable types. The sizes of these two types are the same as one another. The main difference is that the interchangeable type of blocks and rails can be freely exchanged and they can maintain P-class accuracy. Because of strict dimensional control, the interchangeable type linear guideways are a wise choice for customers when rails do not need to be matched for an axis. The model number of the EG series identifies the size, type, accuracy class, preload class, etc.

**(1) Non-interchangeable type**

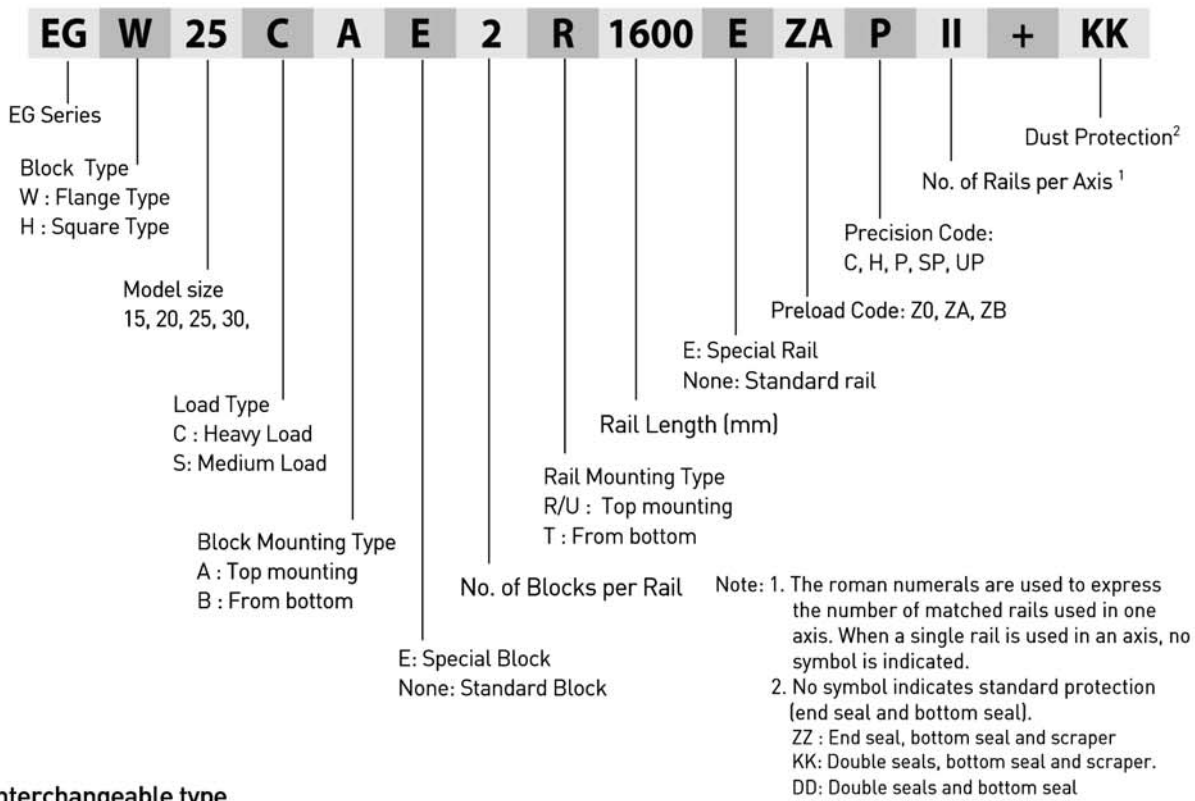

**(2) Interchangeable type**

○ Model Number of EG Block

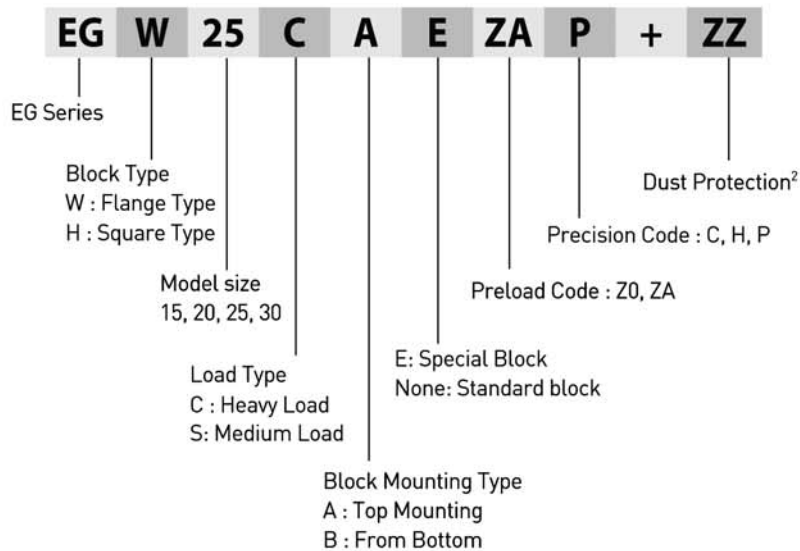

○ Model Number of EG Rail

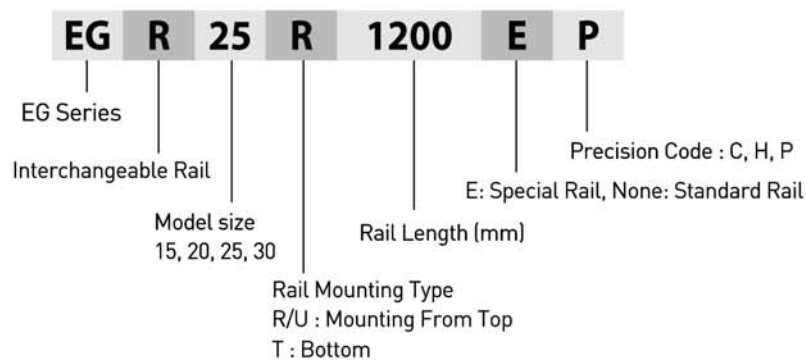

# Linear Guideways

## EG Series

### 2-2-4 Types

#### (1) Block types

HIWIN offers two types of linear guideways, flanged and square types.

**Table 2.27 Block Types**

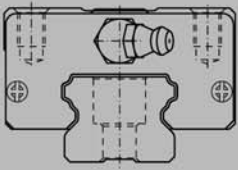
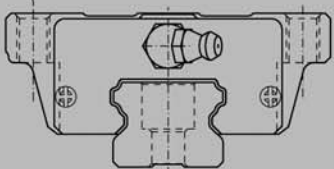
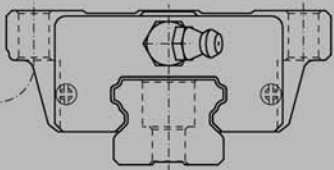
Type	Model	Shape	Height (mm)	Rail Length (mm)	Main Applications
Square	EGH-SA EGH-CA		24	100	<ul style="list-style-type: none"> <li>○ Automation devices</li> <li>○ High-speed transportation equipment</li> <li>○ Precision measuring equipment</li> <li>○ Semiconductor manufacturing equipment</li> <li>○ Woodworking machinery</li> </ul>
			↓	↓	
Flange	EGW-SA EGW-CA		42	4000	
			↓	↓	
			24	100	
			↓	↓	
	EGW-SB EGW-CB		42	4000	
			↓	↓	

#### (2) Rail types

Besides the standard top mounting type, HIWIN also offers bottom mounting type rails.

**Table 2.28 Rail Types**

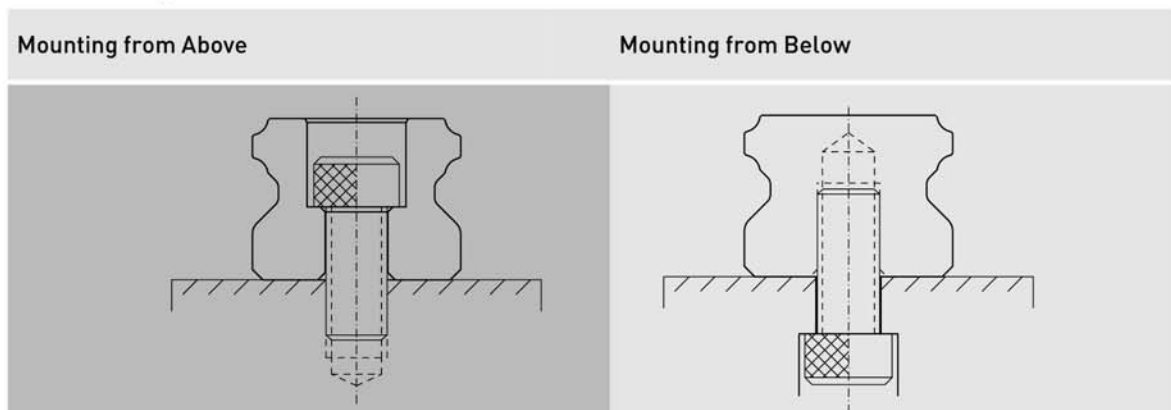



## 2-2-5 Accuracy

The accuracy of the EG series can be classified into 5 classes normal(C), high(H), precision(P), super precision(SP), and ultra precision(UP). Choose the class by referencing the accuracy of selected equipment.

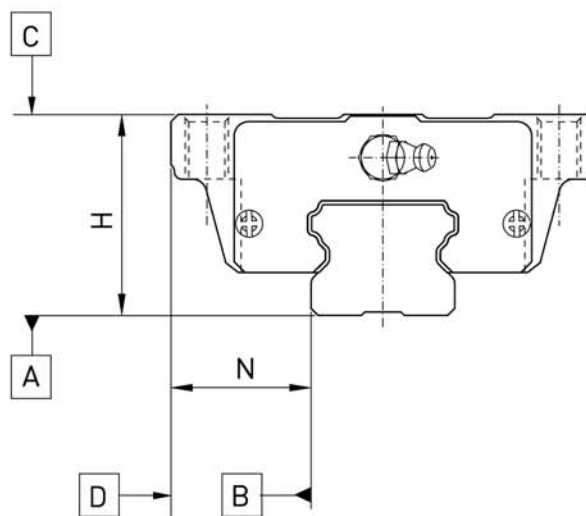

### (1) Accuracy of non-interchangeable guideways

Table 2.29 Accuracy Standards

Unit: mm

Item	EG - 15, 20				
	Normal (C)	High (H)	Precision (P)	Super Precision (SP)	Ultra Precision (UP)
Dimensional tolerance of height H	± 0.1	± 0.03	0 - 0.03	0 - 0.015	0 - 0.008
Dimensional tolerance of width N	± 0.1	± 0.03	0 - 0.03	0 - 0.015	0 - 0.008
Variation of height H	0.02	0.01	0.006	0.004	0.003
Variation of width N	0.02	0.01	0.006	0.004	0.003
Running parallelism of block surface C to surface A	See Table 2.33				
Running parallelism of block surface D to surface B	See Table 2.33				

Table 2.30 Accuracy Standards

Unit: mm

Item	EG - 25, 30				
	Normal (C)	High (H)	Precision (P)	Super Precision (SP)	Ultra Precision (UP)
Dimensional tolerance of height H	± 0.1	± 0.04	0 - 0.04	0 - 0.02	0 - 0.01
Dimensional tolerance of width N	± 0.1	± 0.04	0 - 0.04	0 - 0.02	0 - 0.01
Variation of height H	0.02	0.015	0.007	0.005	0.003
Variation of width N	0.03	0.015	0.007	0.005	0.003
Running parallelism of block surface C to surface A	See Table 2.33				
Running parallelism of block surface D to surface B	See Table 2.33				

# Linear Guideways

## EG Series

### (2) Accuracy of interchangeable

Table 2.31 Accuracy Standards

Unit: mm

Item	EG - 15, 20		
Accuracy Classes	Normal (C)	High (H)	Precision (P)
Dimensional tolerance of height H	± 0.1	± 0.03	± 0.015
Dimensional tolerance of width N	± 0.1	± 0.03	± 0.015
Variation of height H	0.02	0.01	0.006
Variation of width N	0.02	0.01	0.006
Running parallelism of block surface C to surface A	See Table 2.33		
Running parallelism of block surface D to surface B	See Table 2.33		

Table 2.32 Accuracy Standards

Unit: mm

Item	EG - 25, 30		
Accuracy Classes	Normal (C)	High (H)	Precision (P)
Dimensional tolerance of height H	± 0.1	± 0.04	± 0.02
Dimensional tolerance of width N	± 0.1	± 0.04	± 0.02
Variation of height H	0.02	0.015	0.007
Variation of width N	0.03	0.015	0.007
Running parallelism of block surface C to surface A	See Table 2.33		
Running parallelism of block surface D to surface B	See Table 2.33		

### (3) Accuracy of running parallelism

Table 2.33 Accuracy of Running Parallelism

Rail Length (mm)	Accuracy (µm)				
	C	H	P	SP	UP
~ 100	12	7	3	2	2
100 ~ 200	14	9	4	2	2
200 ~ 300	15	10	5	3	2
300 ~ 500	17	12	6	3	2
500 ~ 700	20	13	7	4	2
700 ~ 900	22	15	8	5	3
900 ~ 1,100	24	16	9	6	3
1,100 ~ 1,500	26	18	11	7	4
1,500 ~ 1,900	28	20	13	8	4
1,900 ~ 2,500	31	22	15	10	5
2,500 ~ 3,100	33	25	18	11	6
3,100 ~ 3,600	36	27	20	14	7
3,600 ~ 4,000	37	28	21	15	7

## 2-2-6 Preload

### (1) Definition

A preload can be applied to each guideway. Generally, a linear motion guideway has a negative clearance between the groove and balls in order to improve stiffness and maintain high precision. The figure shows that adding a preload can improve stiffness of the linear guideway. A preload not greater than ZA would be recommended for model sizes smaller than EG20. This will avoid an over-loaded condition that would affect guideway life.

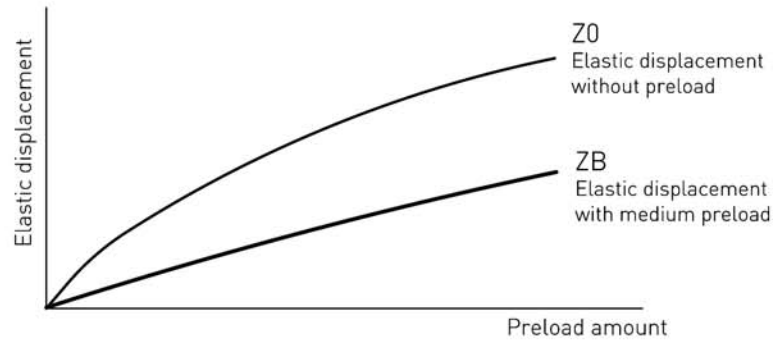

### (2) Preload classes

HIWIN offers three standard preloads for various applications and conditions.

**Table 2.34 Preload Classes**

Class	Code	Preload	Condition
Light Clearance	Z0	0~ 0.02C	Certain load direction, low impact, low precision required
Light Preload	ZA	0.03~0.05C	low load and high precision required
Medium Preload	ZB	0.06C~ 0.08C	High rigidity required, with vibration and impact

Class	Interchangeable Guideway	Non-Interchangeable Guideway
Preload classes	Z0, ZA	Z0, ZA, ZB

Note: The “C” in the preload column denotes basic dynamic load rating.

## 2-2-7 Lubrication

### (1) Grease

#### ○ Grease nipple

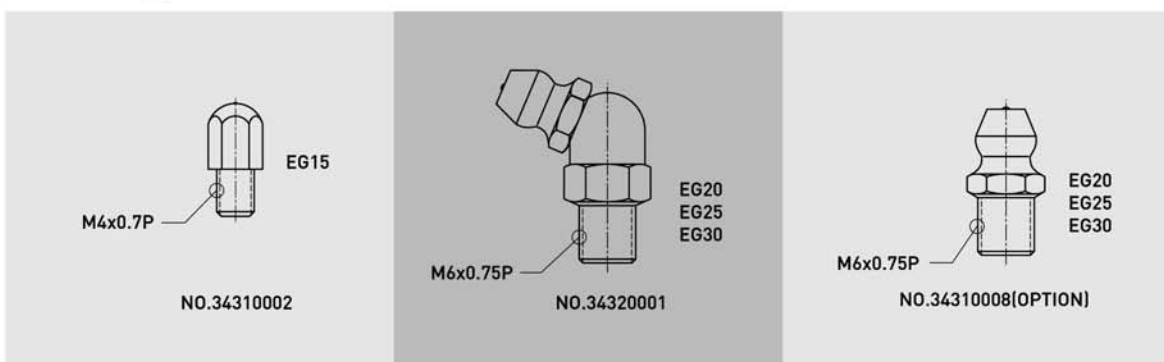

# Linear Guideways

## EG Series

### O Mounting location

The standard location of the grease fitting is at both ends of the block, the nipple may be mounted in the side or top of the block. For lateral installation, we recommend that the nipple be mounted to the non-reference side, otherwise please contact us. When lubricating from above, in the recess for the O-ring, a smaller, preformed recess can be found. Preheat the 0.8 mm diameter metal tip. Carefully open the small recess with the metal tip and pierce through it. Insert a round sealing ring into the recess. (The round sealing ring is not supplied with the block) Do not open the small recess with a drill bit this may introduce the danger of contamination. It is possible to carry out the lubrication by using the oil-piping joint.

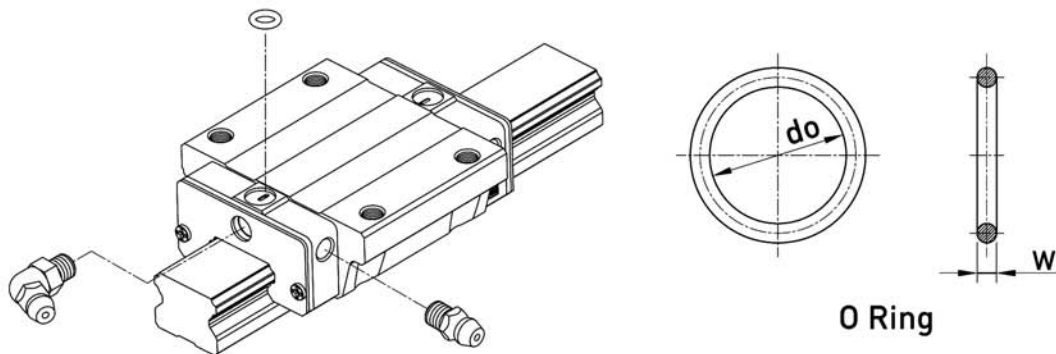
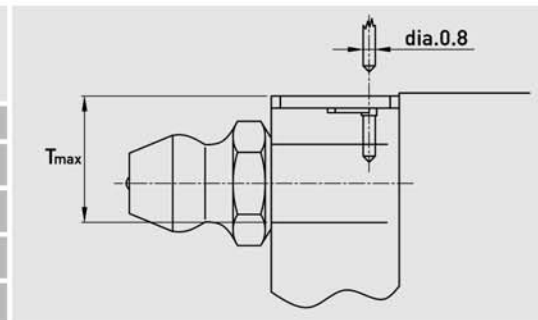

Table 2.35 O-Ring size and max. permissible depth for piercing

Size	O-Ring		Lube hole at top: max. permissible depth for piercing $T_{max}$
	do	W	
	(mm)	(mm)	(mm)
EG 15	$2.5 \pm 0.15$	$1.5 \pm 0.15$	6.9
EG 20	$4.5 \pm 0.15$	$1.5 \pm 0.15$	8.4
EG 25	$4.5 \pm 0.15$	$1.5 \pm 0.15$	10.4
EG 30	$4.5 \pm 0.15$	$1.5 \pm 0.15$	10.4



### O The oil amount for a block filled with grease

Table 2.36 The oil amount for a block filled with grease

Size	Medium Load [cm <sup>3</sup> ]	Heavy Load [cm <sup>3</sup> ]	Size	Medium Load [cm <sup>3</sup> ]	Heavy Load [cm <sup>3</sup> ]
EG 15	0.8	1.4	EG 25	2.8	4.6
EG 20	1.5	2.4	EG 30	3.7	6.3

### O Frequency of replenishment

Check the grease every 100 km, or every 3-6 months.

**(2) Oil**

The recommended viscosity of oil is about 32~150cSt. If you need to use oil-type lubrication, please inform us, then the block will not be prelubricated before shipment.

**○ Types of oil piping joint**

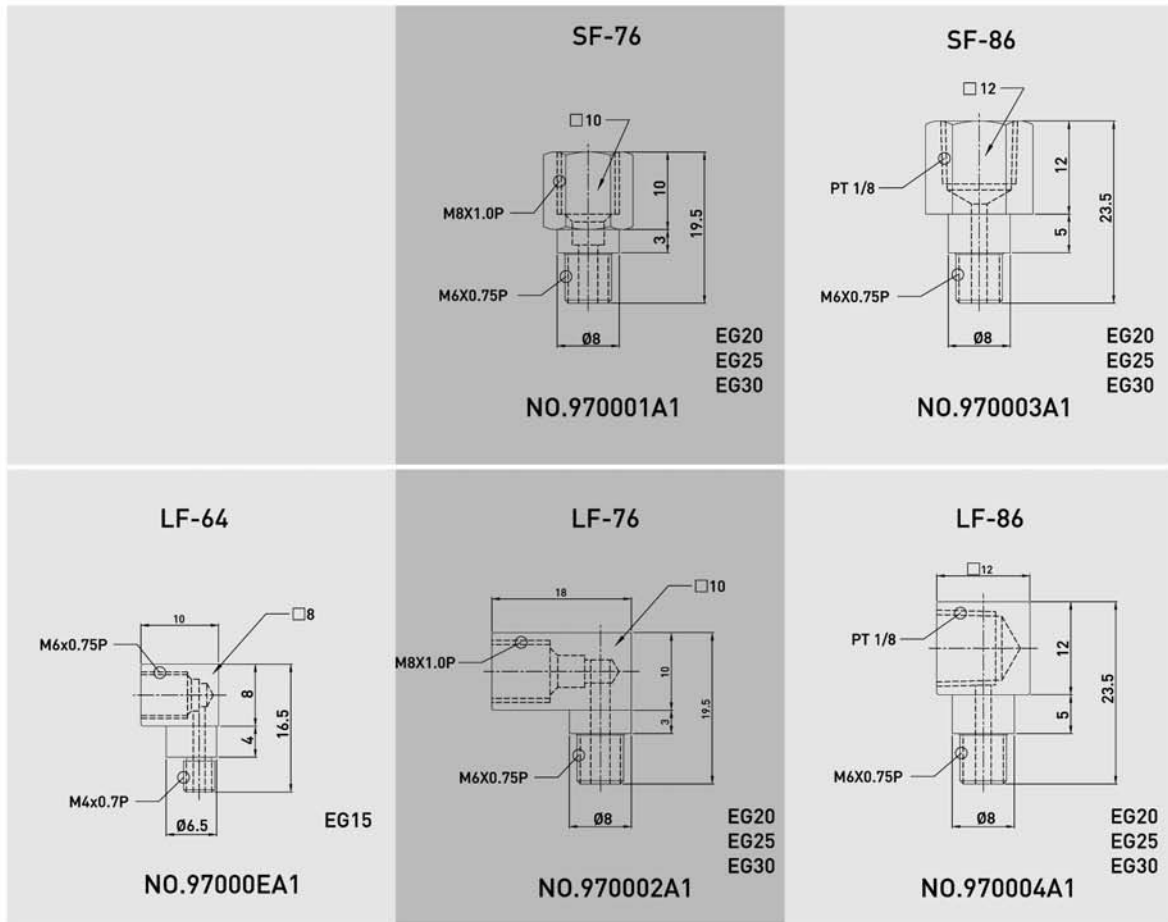

**○ Oil feeding rate**

**Table 2.37 oil feed rate**

Size	feed rate (cm <sup>3</sup> /hr)	Size	feed rate (cm <sup>3</sup> /hr)
EG 15	0.1	EG 25	0.167
EG 20	0.133	EG 30	0.2

# Linear Guideways

## EG Series

### 2-2-8 Dust Protection Equipment

#### (1) Codes of equipment

If the following equipment is needed, please indicate the code followed by the model number.

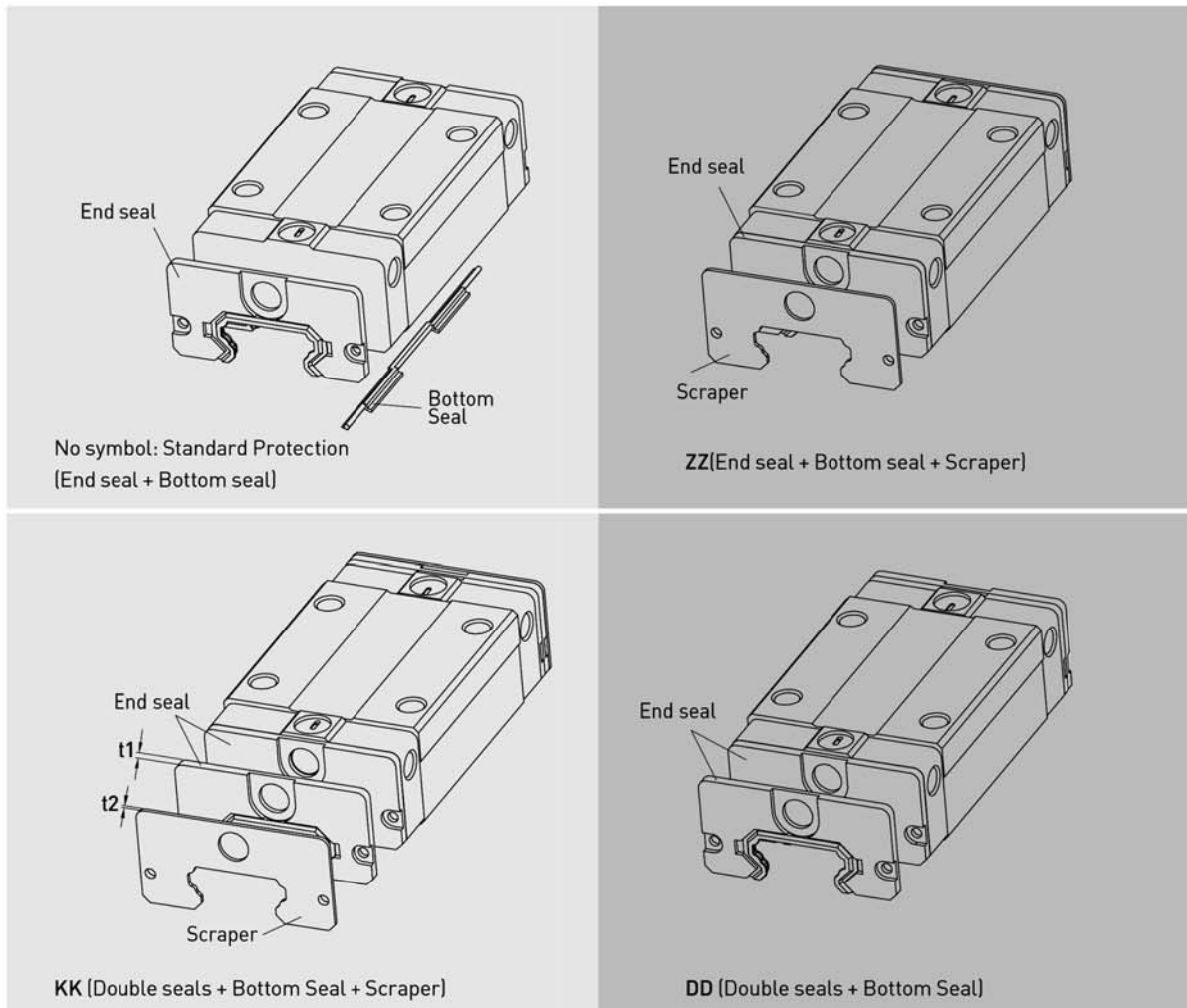

#### (2) End seal and bottom seal

Protects against contaminants entering the block. Reduces potential for groove damage resulting in a reduction of life ratings.

#### (3) Double seals

Removes foreign matter from the rail preventing contaminants from entering the block.

Table 2.38 Dimensions of end seal

Size	Thickness (t1) (mm)	Size	Thickness (t1) (mm)
EG 15	2	EG 25	2
EG 20	2	EG 30	2

#### (4) Scraper

Clears larger contaminants, such as weld spatter and metal cuttings, from the rail. Metal scraper protects end seals from excessive damage.

**Table 2.39 Dimensions of Scraper**

Size	Thickness (t2) (mm)	Size	Thickness (t2) (mm)
EG 15	0.8	EG 25	1
EG 20	0.8	EG 30	1

#### (5) Bolt caps for rail mounting holes

Rail mounting hole caps prevent foreign matter from accumulating in the mounting holes. Caps are included with the rail package.



**Table 2.40 Dimensions of Bolt Caps for Rail Mounting Holes**

Rail size	Bolt size	Diameter(D) (mm)	Thickness(H) (mm)	Rail size	Bolt size	Diameter(D) (mm)	Thickness(H) (mm)
EGR15R	M3	6.3	1.2	EGR30R	M6	11.3	2.5
EGR20R	M5	9.7	2.2	EGR15U	M4	7.7	1.1
EGR25R	M6	11.3	2.5	EGR30U	M8	14.3	3.3

### 2-2-9 Friction

The maximum value of resistance per end seal are as shown in the table.

**Table 2.41 Seal Resistance**

Size	Resistance (kgf)	Size	Resistance (kgf)
EG15	0.1	EG25	0.1
EG20	0.1	EG30	0.15

### 2-2-10 Mounting Surface Accuracy Tolerance

Because of the circular-arc contact design, the EG linear guideway can withstand surface-error installation and deliver smooth linear motion. When the mounting surface meets the accuracy requirements of the installation, the high accuracy and rigidity of the guideway will be obtained without any difficulty. For faster installation and smoother movement, HIWIN offers a preload with normal clearance because of its ability to absorb higher deviations in mounting surface inaccuracies.

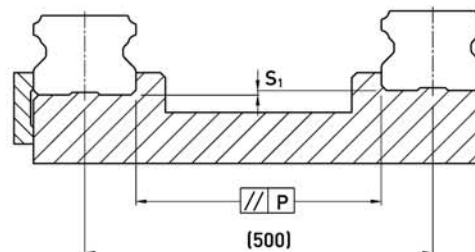

**Table 2.42 Max. Parallelism Tolerance (P)**

unit:  $\mu\text{m}$

Size	Preload classes		
	Z0	ZA	ZB
EG15	25	18	-
EG20	25	20	18
EG25	30	22	20
EG30	40	30	27

# Linear Guideways

## EG Series

Table 2.43 Max. Tolerance of Reference Surface Height (S<sub>1</sub>)

unit: μm

Size	Preload classes		
	Z0	ZA	ZB
EG15	130	85	-
EG20	130	85	50
EG25	130	85	70
EG30	170	110	90

### 2-2-11 Installation Precautions

#### (1) Shoulder heights and chamfers

Improper shoulder heights and chamfers of mounting surfaces will cause deviations in accuracy and rail or block interference with the chamfered part.

When recommended shoulder heights and chamfers are used, problems with installation accuracy should be eliminated.

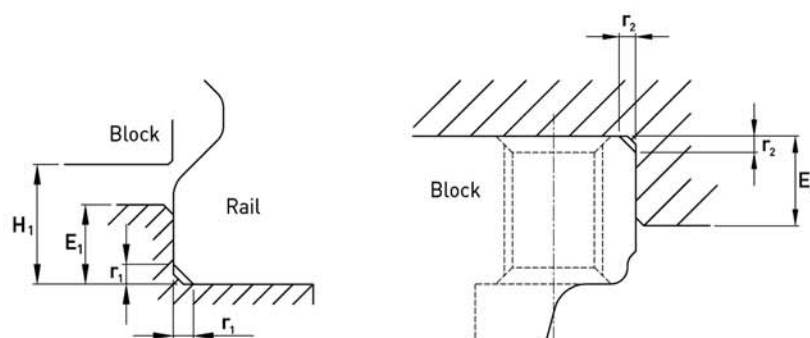

Table 2.44 Shoulder Heights and Chamfers

unit: mm

Size	Max. chamfers of the rail	Max. chamfers of the rail	Shoulder height of the rail	Shoulder height of the block	Clearance under block
	r <sub>1</sub> (mm)	r <sub>2</sub> (mm)	E <sub>1</sub> (mm)	E <sub>2</sub> (mm)	H <sub>1</sub> (mm)
EG15	0.5	0.5	2.7	5.0	4.5
EG20	0.5	0.5	5.0	7.0	6.0
EG25	1.0	1.0	5.0	7.5	7.0
EG30	1.0	1.0	7.0	7.0	10.0

#### (2) Tightening Torque of Bolts for Installation

Improperly tightened mounting bolts will seriously affect the accuracy of linear guide installations. Please see Table 2-43 for recommended tightening torque.

Table 2.45 Tightening Torque

Size	Bolt size	Torque N-cm (kgf-cm)	Size	Bolt size	Torque N-cm (kgf-cm)
EG 15	M3 x 0.5P x 16L	186(19)	EG 25	M6 x 1P x 20L	1,373(140)
EG 20	M5 x 0.8P x 16L	883(90)	EG 30	M6 x 1P x 25L	1,373(140)

Note: 1 kgf = 9.81 N



## 2-2-12 Standard and Maximum Lengths of Rail

HIWIN offers a number of standard rail lengths. Standard rail lengths feature end mounting hole placements set to predetermined values (E). For non-standard rail lengths, be sure to specify the E-value to be no greater than 1/2 the pitch (P) dimension. An E-value greater than this will result in unstable rail ends.

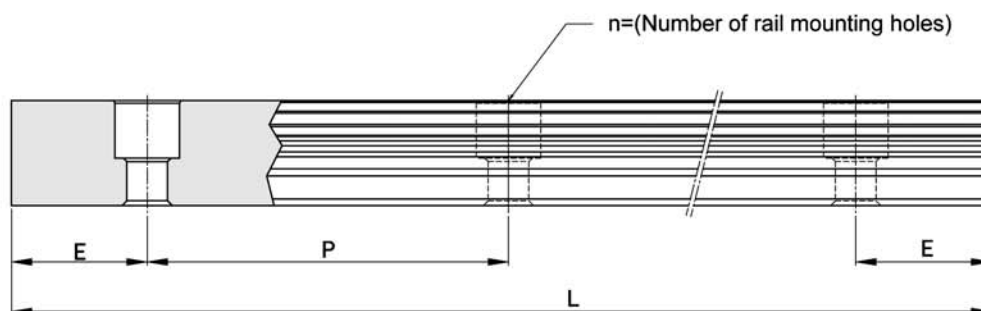

$$L = (n - 1) \times P + 2 \times E \quad \dots \dots \dots \text{Eq.2.2}$$

- L : Total length of rail (mm)
- n : Number of mounting holes
- P : Distance between any two holes (mm)
- E : Distance from the center of the last hole to the edge (mm)

**Table 2.46 Rail Standard Length and Max. Length**

unit: mm

Item	EGR15	EGR20	EGR25	EGR30
Standard Length L(n)	160(3)	220(4)	220(4)	280(4)
	220(4)	280(5)	280(5)	440(6)
	280(5)	340(6)	340(6)	600(8)
	340(6)	460(8)	460(8)	760(10)
	460(8)	640(11)	640(11)	1,000(13)
	640(11)	820(14)	820(14)	1,640(21)
	820(14)	1,000(17)	1,000(17)	2,040(26)
		1,240(21)	1,240(21)	2,520(32)
	1,600(27)	1,600(27)	3,000(38)	
Pitch (P)	60	60	60	80
Distance to End (E <sub>s</sub> )	20	20	20	20
Max. Standard Length	1960(33)	4,000(67)	4,000(67)	3,960(50)
Max. Length	2000	4,000	4,000	4,000

- Note :
1. Tolerance of E value for standard rail is 0.5--0.5 mm. Tolerance of E value for jointed rail is 0--0.3 mm.
  2. Maximum standard length means the max. rail length with standard E value on both sides.
  3. If different E value is needed, please contact HIWIN.

# Linear Guideways

## EG Series

### 2-2-13 Dimensions for HIWIN EG Series

#### (1) EGH-SA / EGH-CA

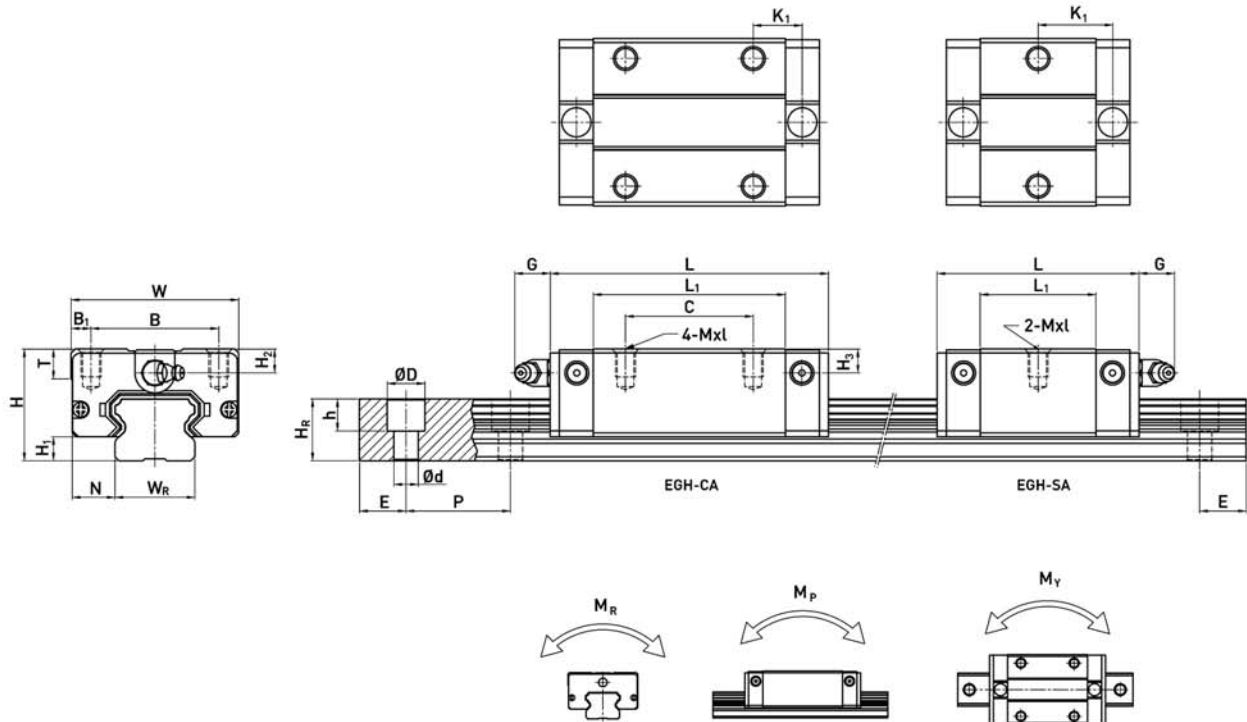

Model No.	Dimensions of Assembly (mm)			Dimensions of Block (mm)											Dimensions of Rail (mm)					Mounting Bolt for Rail (mm)	Basic Dynamic Load Rating C (kN)	Basic Static Load Rating Co (kN)	Static Rated Moment			Weight					
	H	H1	N	W	B	B1	C	L1	L	K1	G	Mxl	T	H2	H3	Wr	Hr	D	h				d	P	E	MR	MP	MY	Block	Rail	
	mm	mm	mm	mm	mm	mm	mm	mm	mm	mm	mm	mm	mm	mm	mm	mm	mm	mm	mm				mm	mm	mm	kN-m	kN-m	kN-m	kg	kg/m	
EGH15SA	24	4.5	9.5	34	26	4	-	23.1	40.1	14.8	-	M4x6	6	5.5	6	15	12.5	6	4.5	3.5	60	20	M3x16	5.35	9.40	0.08	0.04	0.04	0.09	1.25	
EGH15CA							26	39.8	56.8	10.15														7.83	16.19	0.13	0.10	0.10	0.15		
EGH20SA							-	29	50	18.75		M5x7	7.5	6	6	20	15.5	9.5	8.5	6	60	20	M5x16	7.23	12.74	0.13	0.06	0.06	0.15	2.08	
EGH20CA							32	48.1	69.1	12.3															10.31	21.13	0.22	0.16	0.16	0.24	
EGH25SA							-	35.5	59.1	21.9		M6x9	8	8	8	23	18	11	9	7	60	20	M6x20	11.40	19.50	0.23	0.12	0.12	0.25	2.67	
EGH25CA							35	59	82.6	16.15															16.27	32.40	0.38	0.32	0.32	0.41	
EGH30SA							-	41.5	69.5	26.75		M8x12	9	8	9	28	23	11	9	7	80	20	M6x25	16.42	28.10	0.40	0.21	0.21	0.45	4.35	
EGH30CA							40	70.1	98.1	21.05															23.70	47.46	0.68	0.55	0.55	0.76	

Note : 1 kgf = 9.81 N



# Linear Guideways

## EG Series

### (3) EGW-SB / EGW-CB

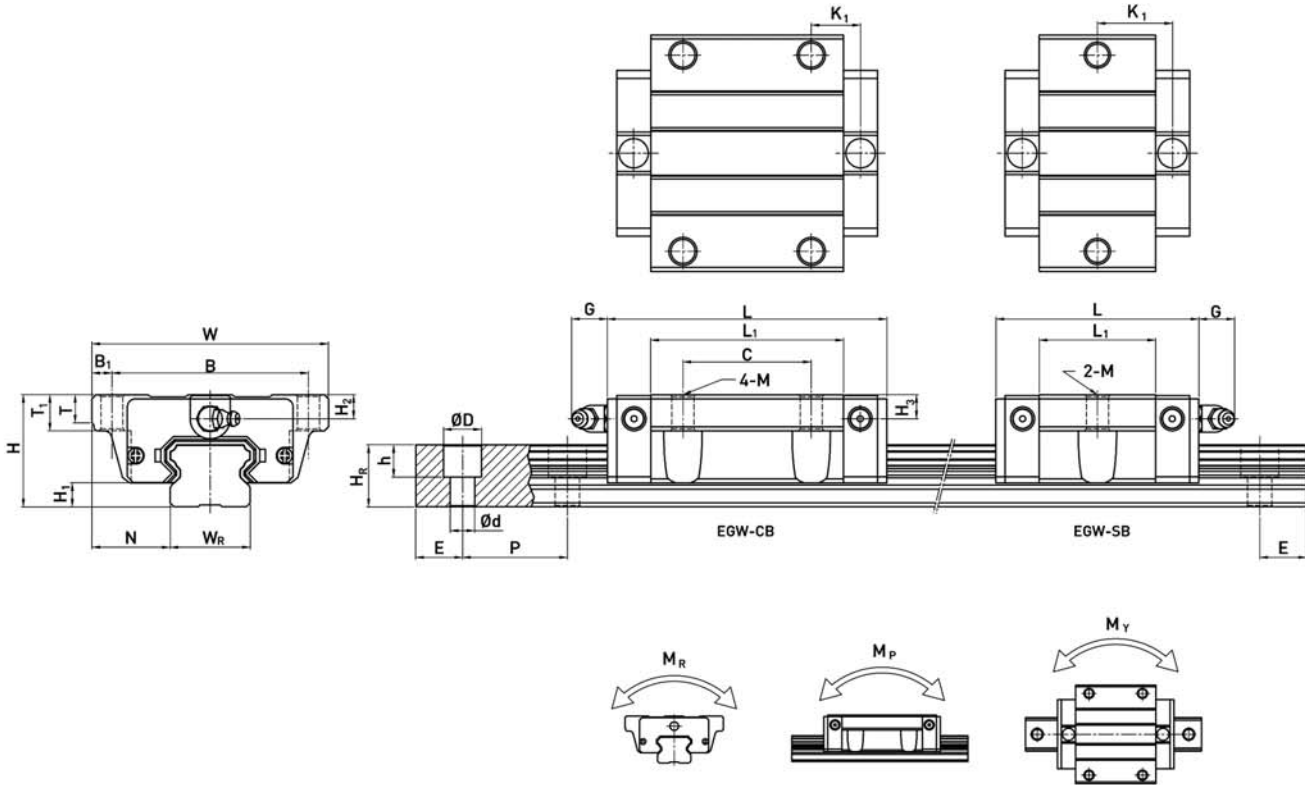

Model No.	Dimensions of Assembly (mm)			Dimensions of Block (mm)											Dimensions of Rail (mm)					Mounting Bolt for Rail (mm)	Basic Dynamic Load Rating C(kN)	Basic Static Load Rating C <sub>0</sub> (kN)	Static Rated Moment			Weight							
	H	H <sub>1</sub>	N	W	B	B <sub>1</sub>	C	L <sub>1</sub>	L	K <sub>1</sub>	G	M	T	T <sub>1</sub>	H <sub>2</sub>	H <sub>3</sub>	W <sub>R</sub>	H <sub>R</sub>	D				h	d	P	E	C <sub>0</sub> (kN)	C <sub>0</sub> (kN)	M <sub>R</sub> (kN-m)	M <sub>P</sub> (kN-m)	M <sub>Y</sub> (kN-m)	Block (kg)	Rail (kg/m)
EGW 15SB	24	4.5	18.5	52	41	5.5	-	23.1	40.1	14.8	5.7	φ4.5	5	7	5.5	6	15	12.5	6	4.5	3.5	60	20	M3x16	5.35	9.40	0.08	0.04	0.04	0.12	1.25		
EGW 15CB							26	39.8	56.8	10.15															7.83	16.19	0.13	0.10	0.10	0.21			
EGW 20SB	28	6	19.5	59	49	5	-	29	50	18.75	12	φ5.5	7	9	6	6	20	15.5	9.5	8.5	6	60	20	M5x16	7.23	12.74	0.13	0.06	0.06	0.19	2.08		
EGW 20CB							32	48.1	69.1	12.3															10.31	21.13	0.22	0.16	0.16	0.32			
EGW 25SB	33	7	25	73	60	6.5	-	35.5	59.1	21.9	12	φ7	7.5	10	8	8	23	18	11	9	7	60	20	M6x20	11.40	19.50	0.23	0.12	0.12	0.35	2.67		
EGW 25CB							35	59	82.6	16.15															16.27	32.40	0.38	0.32	0.32	0.59			
EGW 30SB	42	10	31	90	72	9	-	41.5	69.5	26.75	12	φ9	7	10	8	9	28	23	11	9	7	80	20	M6x25	16.42	28.10	0.40	0.21	0.21	0.62	4.35		
EGW 30CB							40	70.1	98.1	21.05															23.70	47.46	0.68	0.55	0.55	1.04			

Note : 1 kgf = 9.81 N

#### (4) Dimensions for EGR-U (large mounting hole, rail mounting from top)

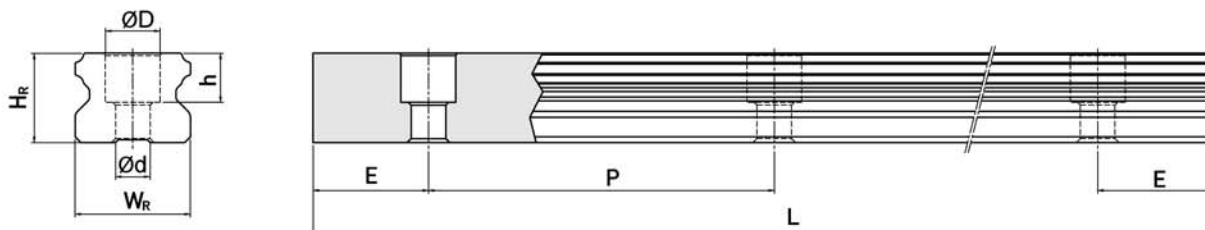

Model No.	Mounting Bolt for Rail(mm)	Dimensions of Rail (mm)							Weight (kg/m)
		W <sub>R</sub>	H <sub>R</sub>	D	h	d	P	E	
EGR15U	M4x16	15	12.5	7.5	5.3	4.5	60	20	1.23
EGR30U	M8x25	28	23	14	12	9	80	20	4.23

#### (5) Dimensions for EGR-T (rail mounting from bottom)

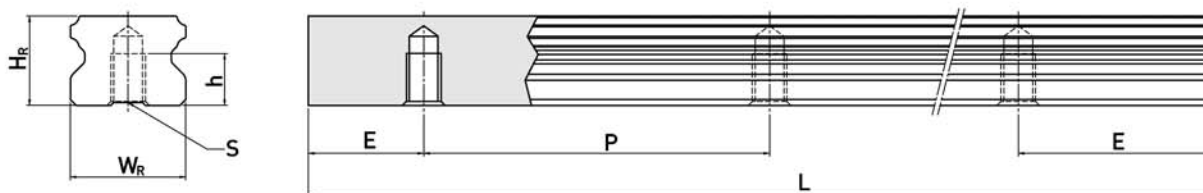

Model No.	Dimensions of Rail (mm)						Weight (kg/m)
	W <sub>R</sub>	H <sub>R</sub>	S	h	P	E	
EGR15T	15	12.5	M5 x 0.8P	7	60	20	1.26
EGR20T	20	15.5	M6 x 1P	9	60	20	2.15
EGR25T	23	18	M6 x 1P	10	60	20	2.79
EGR30T	28	23	M8 x 1.25P	14	80	20	4.42

# Linear Guideways

## MG Series

### 2-3 MG Series - Miniature Linear Guideway

#### 2-3-1 Features of MGN Series

1. Tiny and light weight, suitable for miniature equipment.
2. All materials in special grade of stainless steel for anti-corrosion size 9 and 12 are also available in alloy steel.
3. Gothic arch contact design can sustain the load from all directions and offer high rigidity and high accuracy.
4. Steel balls will be held by miniature retainer to avoid the balls from falling out even when the blocks are removed from the rail installation.
5. Interchangeable types are available in certain precision grades.

#### 2-3-2 Construction of MGN Series

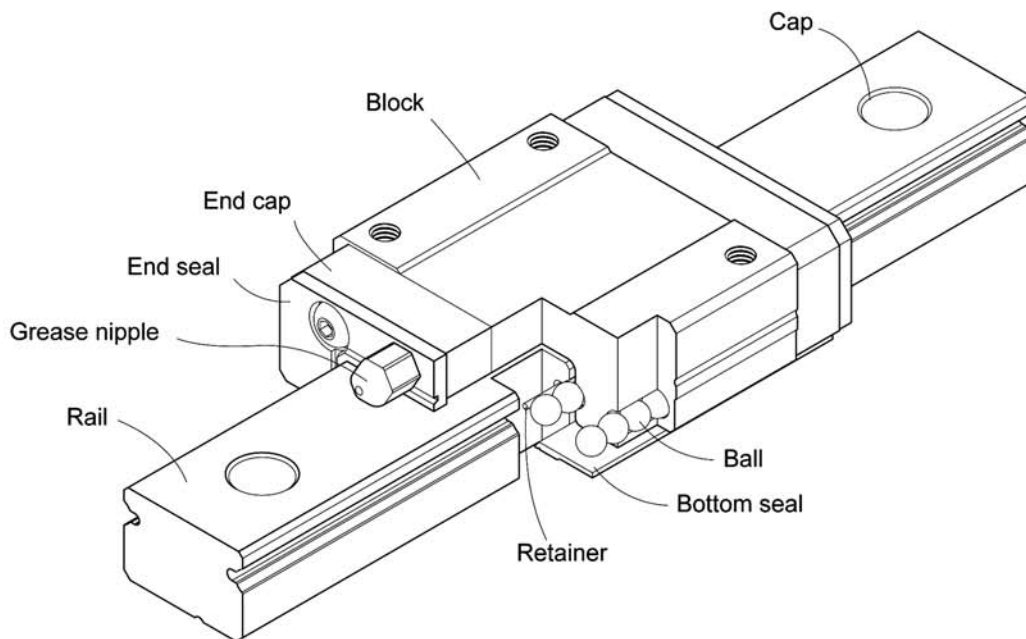

- Rolling circulation system: Block, rail, end cap and retainer
- Lubrication system: The grease nipple is available for MGN15, grease gun can be used for lubricating.
- Dust protection system: End seal, bottom seal (optional size 9,12,15), cap (size12,15)

### 2-3-3 Feature of MGW Series

The design feature of wide type miniature guideway-MGW:

1. The design of enlarged width has increased the capacity of moment load.
2. Gothic arch contact design has high rigidity characteristic in all directions.
3. Steel balls will be held by miniature retainer to avoid the balls from falling out even when the block are removed from the rail installation.
4. All metallic components are made of stainless steel for anti-corrosion purpose.

### 2-3-4 Configuration of MGW Series

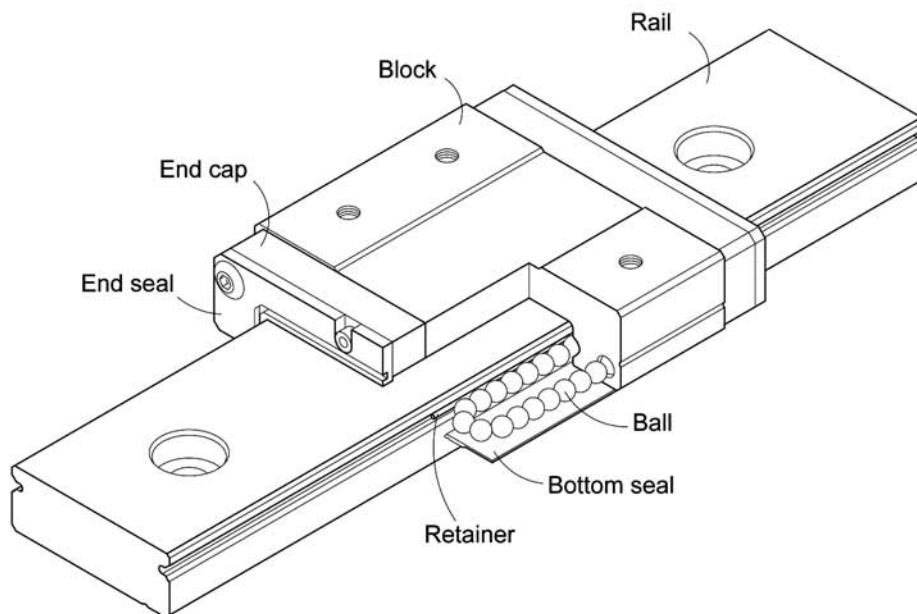

- Rolling circulation system: Block, rail, end cap and retainer
- Lubrication system: The grease nipple is available for MGW15, grease gun can be used for lubricating.
- Dust protection system: End seal, bottom seal (optional size 9,12,15), cap (size12,15)

### 2-3-5 Application

MGN/MGW series can be used in many fields, such as semiconductor equipment, PCB assembly equipment, medical equipment, robotics, measuring equipment, office automation equipment, and other miniature sliding machinery.

### 2-3-6 Model Number of MGN/MGW Series

MGN and MGW series linear guideway can be classified into non-interchangeable and interchangeable types. The sizes of two types are same. The interchangeable type is more convenient due to rails can be replaced. However, its precision is less than non-interchangeable type. Because of strict dimensional control, the interchangeable type linear guideway is a smart choice for customers when rails don't need to be paired for an axis. The model number contains the information of the size, type, accuracy class, preload class, and more.

# Linear Guideways

## MG Series

### (1) Non-interchangeable type

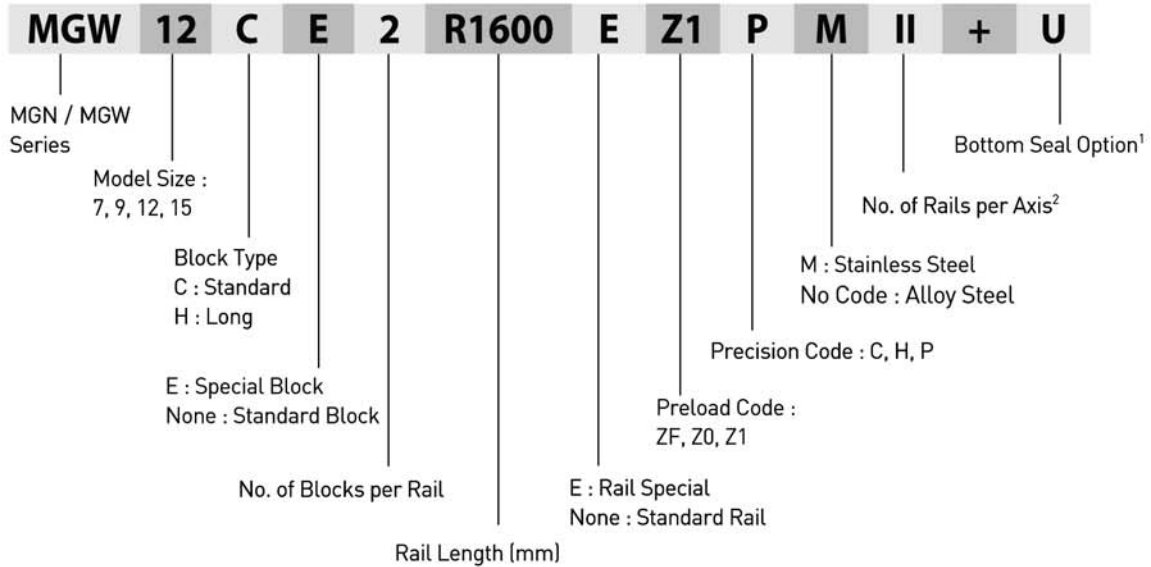

Note: 1. The bottom seal is available for MGN & MGW 9, 12, 15.  
 2. The roman numerals express the number of rails used in one axis. No symbol indicates single rail in an axis.

### (2) Interchangeable type

#### ○ Interchangeable Block

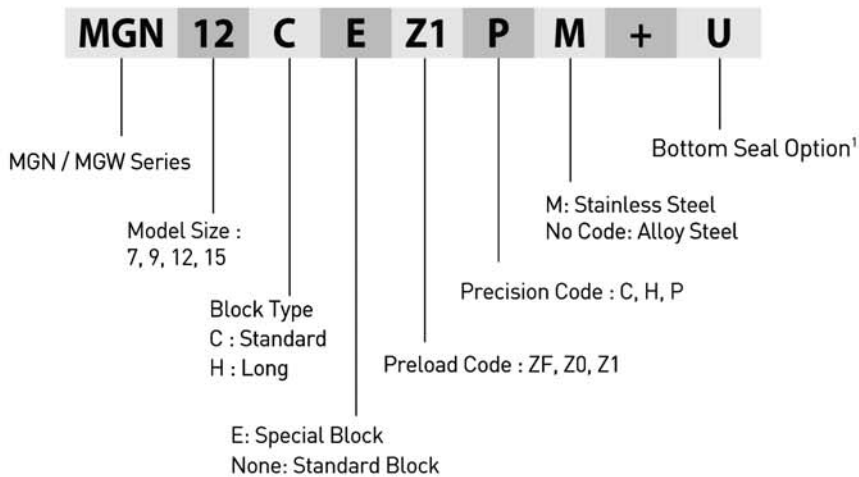

#### ○ Interchangeable Rail

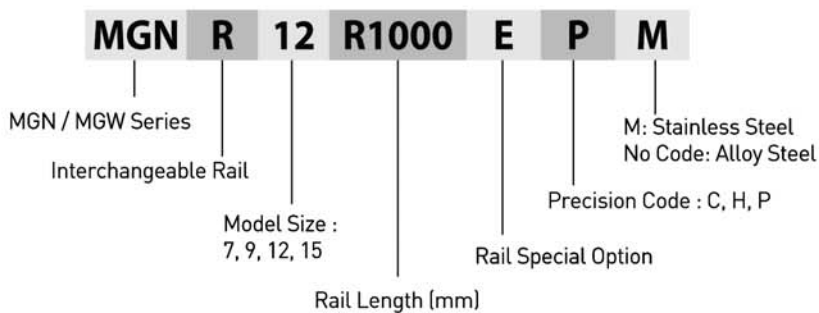



## 2-3-7 Accuracy Classes

The accuracy of MGN/MGW series can be classified into three classes: normal (C), high (H), precision (P), super precision (SP), ultra precision (UP). Customers can select the proper linear guideway by the required accuracy of the application.

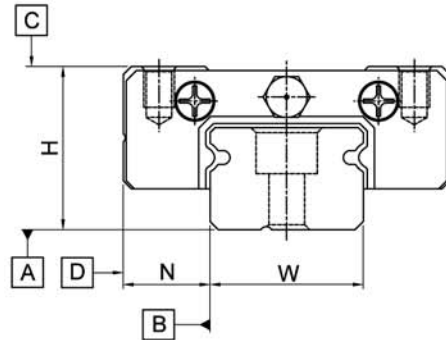

### (1) Non-interchangeable

The accuracy values are taken at the central part of each block.

**Table 2.47 Accuracy Standard of Non-interchangeable Type**

Unit: mm

Accuracy Classes	Normal (C)	High (H)	Precision (P)
Dimensional tolerance of height H	± 0.04	± 0.02	± 0.01
Dimensional tolerance of width N	± 0.04	± 0.025	± 0.015
Pair Variation of height H	0.03	0.015	0.007
Pair Variation of width N (Master Rail)	0.03	0.02	0.01
Running parallelism of block surface C to surface A	According to Table 2.49		
Running parallelism of block surface D to surface B	According to Table 2.49		

### (2) Interchangeable

Height variation between the interchangeable and non-interchangeable types is minimal.

**Table 2.48 Accuracy Standard of Interchangeable Type**

Unit: mm

Accuracy Classes	Normal (C)	High (H)	Precision (P)
Dimensional tolerance of height H	± 0.04	± 0.02	± 0.01
Dimensional tolerance of width N	± 0.04	± 0.025	± 0.015
One Set	Pair Variation of height H	0.03	0.015
	Pair Variation of width N	0.03	0.02
Pair Variation of width N (Master Rail)	0.07	0.04	0.02
Running parallelism of block surface C to surface A	According to Table 2.49		
Running parallelism of block surface D to surface B	According to Table 2.49		

# Linear Guideways

## MG Series

### (3) Accuracy of running parallelism

The running parallelism C to A and D to B are related to the rail length.

**Table 2.49 Accuracy of Running Parallelism**

Rail Length (mm)	Accuracy ( $\mu\text{m}$ )			Rail Length (mm)	Accuracy ( $\mu\text{m}$ )		
	(C)	(H)	(P)		(C)	(H)	(P)
50 & under	12	6	2	315 ~ 400	18	11	6
50 ~ 80	13	7	3	400 ~ 500	19	12	6
80 ~ 125	14	8	3.5	500 ~ 630	20	13	7
125 ~ 200	15	9	4	630 ~ 800	22	14	8
200 ~ 250	16	10	5	800 ~ 1,000	23	16	9
250 ~ 315	17	11	5	1,000 ~ 1,200	25	18	11

### 2-3-8 Preload

MGN/MGW series provide three preload levels for various applications.

**Table 2.50 Preload Classes**

Class	Code	Preload	Accuracy
Light Clearance	ZF	Clearance 4-10 $\mu\text{m}$	C
Very Light Preload	Z0	0	C~P
Light Preload	Z1	0.02C	C~P

Note: "C" in column preload means basic dynamic load rating.

### 2-3-9 Dust Proof Accessories

End seals and standard accessories fixed on both sides of the block can prevent dust from entering the block, so the accuracy and service life of a linear guideway can be maintained. Bottom seals are fixed under the skirt portion of the block to prevent dust from entering. Customers can order bottom seals by adding the mark "+U" followed by the model number. Sizes 12 and 15 provide bottom seals as an option, but sizes 7 and 9 do not offer the option due to the space limit of  $H_1$ . If the linear guideway is equipped with a bottom seal, the lateral mounting surface of the rail must not exceed  $H_1$ .

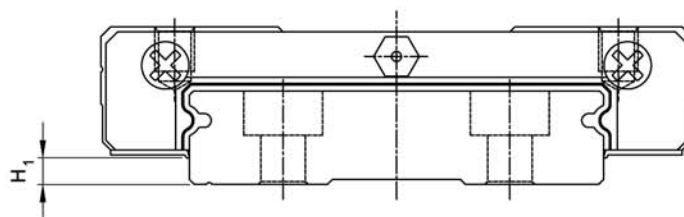

**Table 2.51**

Size	Bottom seal	$H_1$ , mm
MGN 7	-	-
MGN 9	-	-
MGN 12	●	2
MGN 15	●	3
MGW 7	-	-
MGW 9	-	-
MGW 12	●	2.6
MGW 15	●	2.6

## 2-3-10 Cautions for Installation

### ○ Shoulder heights and fillets

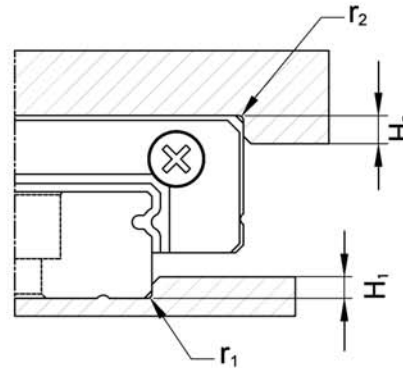

Table 2.52 Shoulder Heights and Fillets

Size	Max. radius of fillets	Max. radius of fillets	Shoulder height	Shoulder height
	$r_1$ (mm)	$r_2$ (mm)	$H_1$ (mm)	$H_2$ (mm)
MGN 7	0.2	0.2	1.2	3
MGN 9	0.2	0.3	1.7	3
MGN 12	0.3	0.4	1.7	4
MGN 15	0.5	0.5	2.5	5
MGW 7	0.2	0.2	1.7	3
MGW 9	0.3	0.3	2.5	3
MGW 12	0.4	0.4	3	4
MGW 15	0.4	0.8	3	5

### ○ Tightening torque of bolts for installation

Improperly tightening the rail mounting bolts will seriously affect the accuracy of the linear guideway. The following table lists the recommended tightening torque for the specific sizes of bolts.

Table 2.53 Tightening Torque

Size	Bolt size	Torque (kgf-cm)
MGN 7	M2	5.9
MGN 9	M3	19
MGN 12	M3	19
MGN 15	M3	19
MGW 7	M3	19
MGW 9	M3	19
MGW 12	M4	40
MGW 15	M4	40

# Linear Guideways

## MG Series

### 2-3-11 Standard and Maximum Lengths of Rail

HIWIN stocks standard lengths of rail. If a non-standard length is required, it is recommended to specify the E value to be not greater than 1/2 of the pitch (P) to avoid instability at the end of the rail, and the E value should not be less than  $E_{min}$  in order to prevent breaking the end mounting hole.

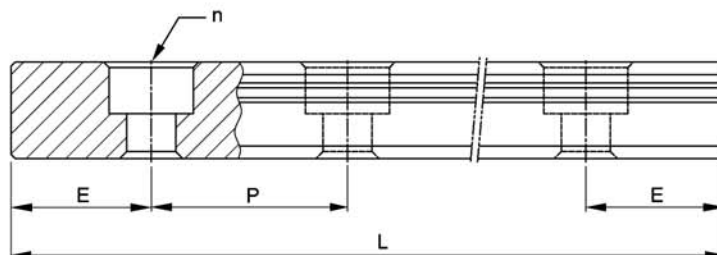

$$L = (n - 1) \times P + 2 \times E \dots\dots\dots \text{Eq.2.3}$$

L : Total length of rail (mm)

n : Number of mounting holes

P : Distance between any two holes (mm)

E : Distance from the center of the last hole to the edge (mm)

Table 2.54

unit: mm

Item	MGNR	MGNR	MGNR	MGNR	MGWR	MGWR	MGWR	MGWR
	7M	9M	12M	15M	7M	9M	12M	15M
Standard Length L(n)	40(3)	55(3)	70(3)	70(2)	80(3)	80(3)	110(3)	110(3)
	55(4)	75(4)	95(4)	110(3)	110(4)	110(4)	150(4)	150(4)
	70(5)	95(5)	120(5)	150(4)	140(5)	140(5)	190(5)	190(5)
	85(6)	115(6)	145(6)	190(5)	170(6)	170(6)	230(6)	230(6)
	100(7)	135(7)	170(7)	230(6)	200(7)	200(7)	270(7)	270(7)
	130(9)	155(8)	195(8)	270(7)	260(9)	230(8)	310(8)	310(8)
		175(9)	220(9)	310(8)		260(9)	350(9)	350(9)
		195(10)	245(10)	350(9)		290(10)	390(10)	390(10)
		275(14)	270(11)	390(10)		350(14)	430(11)	430(11)
		375(19)	320(13)	430(11)		500(19)	510(13)	510(13)
			370(15)	470(12)		710(24)	590(15)	590(15)
			470(19)	550(14)		860(29)	750(19)	750(19)
		570(23)	670(17)			910(23)	910(23)	
		695(28)	870(22)			1070(27)	1070(27)	
Pitch (P)	15	20	25	40	30	30	40	40
Distance to End (E <sub>s</sub> )	5	7.5	10	15	10	10	15	15
Max. Standard Length	595(40)	995(40)	995(40)	990(25)	590(20)	980(33)	1150(29)	1150(29)
Max. Length	600	1000	1000	2000	600	1000	1200	2000

- Note:
1. Tolerance of E value for standard rail is 0.5~0.5 mm. Tolerance of E value for jointed rail is 0~0.3 mm.
  2. Maximum standard length means the max. rail length with standard E value on both sides.
  3. The specification with "M" mark are stainless steel and without "M" mark are alloy steel.
  4. If smaller E value is needed, please contact HIWIN.

## 2-3-12 Dimensions for MGN/MGW Series

### (1) MGN-C / MGN-H

MGN7, MGN9, MGN12

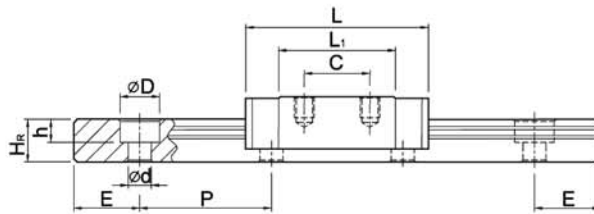
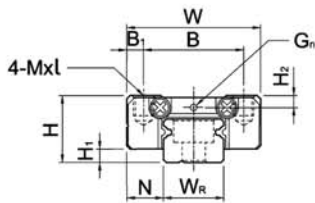

MGN15

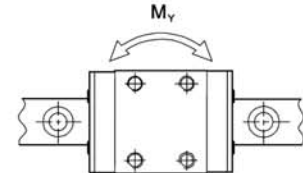
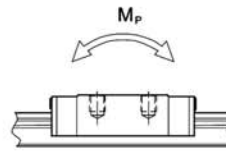
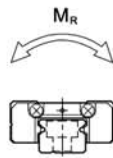
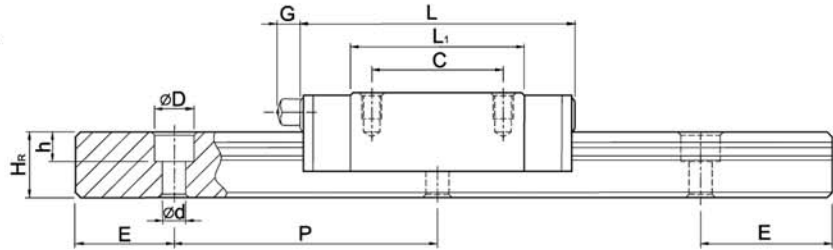
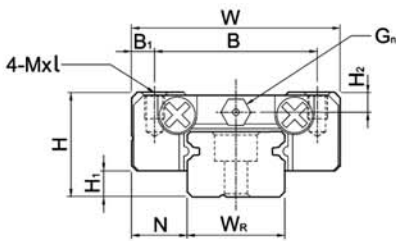

Model No.	Dimensions of Assembly (mm)		Dimensions of Block (mm)										Dimensions of Rail (mm)					Mounting Bolt for Rail (mm)	Basic Dynamic Load Rating C(kgf)	Basic Static Load Rating Co(kgf)	Static Rated Moment			Weight				
	H	H1	N	W	B	B1	C	L1	L	G	Gn	Mxl	H2	WR	Hr	D	h				d	P	E	Mr	Mp	My	Block	Rail
	kgf-m	kgf-m	kgf-m	g	kg/m																							
MGN 7C	8	1.5	5	17	12	2.5	8	13.5	22.5	-	Ø1.2	M2x2.5	1.5	7	4.8	4.2	2.3	2.4	15	5	M2x6	100	127	0.48	0.29	0.29	10	0.22
MGN 7H							13	21.8	30.8													140	200	0.78	0.49	0.49	15	
MGN 9C	10	2	5.5	20	15	2.5	10	18.9	28.9	-	Ø1.2	M3x3	1.8	9	6.5	6	3.5	3.5	20	7.5	M3x8	190	260	1.2	0.75	0.75	16	0.38
MGN 9H							16	29.9	39.9													260	410	2	1.9	1.9	26	
MGN 12C	13	3	7.5	27	20	3.5	15	21.7	34.7	-	Ø1.4	M3x3.5	2.5	12	8	6	4.5	3.5	25	10	M3x8	290	400	2.6	1.4	1.4	34	0.65
MGN 12H							20	32.4	45.4													380	600	3.9	3.7	3.7	54	
MGN 15C	16	4	8.5	32	25	3.5	20	26.7	42.1	4.5	M3	M3x4	3	15	10	6	4.5	3.5	40	15	M3x10	470	570	4.6	2.2	2.2	59	1.06
MGN 15H							25	43.4	58.8													650	930	7.5	5.9	5.9	92	

# Linear Guideways

## MG Series

### (2) MGW-C / MGW-H

MGW7, MGW9, MGW12

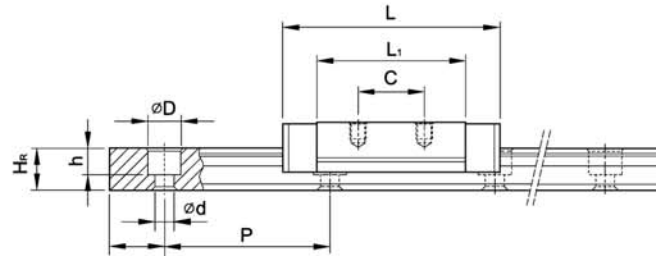
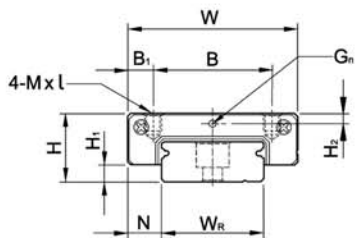

MGW15

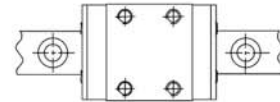
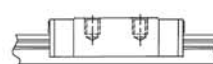
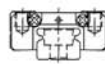
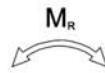
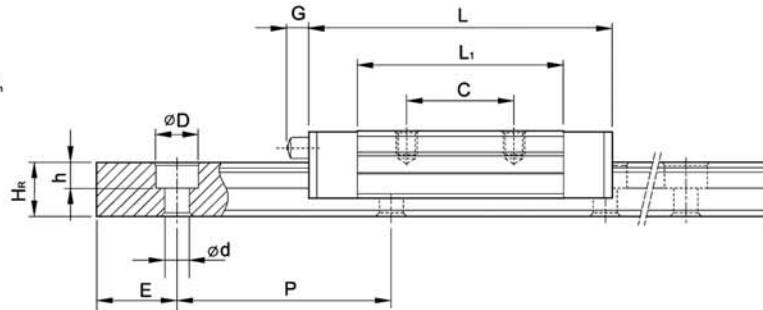
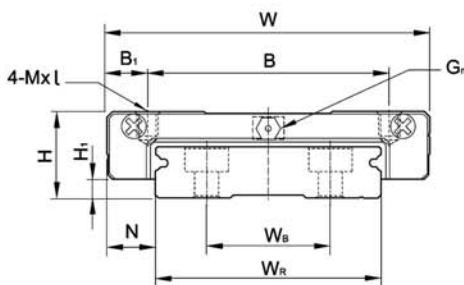

Model No.	Dimensions of Assembly (mm)				Dimensions of Block (mm)								Dimensions of Rail (mm)								Mounting Bolt for Rail (mm)	Basic Dynamic Load Rating C(kgf)	Basic Static Load Rating C <sub>0</sub> (kgf)	Static Rated Moment			Weight				
	H	H <sub>1</sub>	N	W	B	B <sub>1</sub>	C	L <sub>1</sub>	L	G	G <sub>n</sub>	Mxl	H <sub>2</sub>	W <sub>R</sub>	W <sub>B</sub>	H <sub>R</sub>	D	h	d	P				E	C(kgf)	C <sub>0</sub> (kgf)	M <sub>R</sub>	M <sub>P</sub>	M <sub>V</sub>	Block g	Rail kg/m
																											kgf-m	kgf-m	kgf-m		
MGW 7C	9	1.9	5.5	25	19	3	10	21	31.2	-	Ø1.2	M3x3	1.85	14	-	5.2	6	3.2	3.5	30	10	M3x6	140	210	1.6	0.73	0.73	20	0.51		
MGW 7H							19	30.8	41													M3x6	180	320	2.39	1.58	1.58	29			
MGW 9C	12	2.9	6	30	21	4.5	12	27.5	39.3	-	Ø1.4	M3x3	2.4	18	-	7	6	4.5	3.5	30	10	M3x8	280	420	4.09	1.93	1.93	40	0.91		
MGW 9H					23	3.5	24	38.5	50.7													M3x8	350	600	5.56	3.47	3.47	57			
MGW 12C	14	3.4	8	40	28	6	15	31.3	46.1	-	Ø1.4	M3x3.6	2.8	24	-	8.5	8	4.5	4.5	40	15	M4x8	400	570	7.17	2.83	2.83	71	1.49		
MGW 12H					28		28	45.6	60.4													M4x8	520	840	10.47	5.85	5.85	103			
MGW 15C	16	3.4	9	60	45	7.5	20	38	54.8	5.2	M3	M4x4.2	3.2	42	23	9.5	8	4.5	4.5	40	15	M4x10	690	940	20.32	5.78	5.78	143	2.86		
MGW 15H					35		35	57	73.8													M4x10	910	1410	30.48	12.5	12.5	215			

## 2-4 RG Series – High Rigidity Roller Type Linear Guideway

### 2-4-1 Advantages and features

The new RG series from Hiwin features a roller as the rolling element instead of steel balls. The roller series offers super high rigidity and very high load capacities. The RG series is designed with a 45-degree angle of contact. Elastic deformation of the linear contact surface, during load, is greatly reduced thereby offering greater rigidity and higher load capacities in all 4 load directions. The RG series linear guideway offers high performance for high-precision manufacturing and achieving longer service life.

#### (1) Optimal design

FEM analysis was performed to determine the optimal structure of the block and the rail. The unique design of the circulation path allows the RG series linear guideway to offer smoother linear motion.

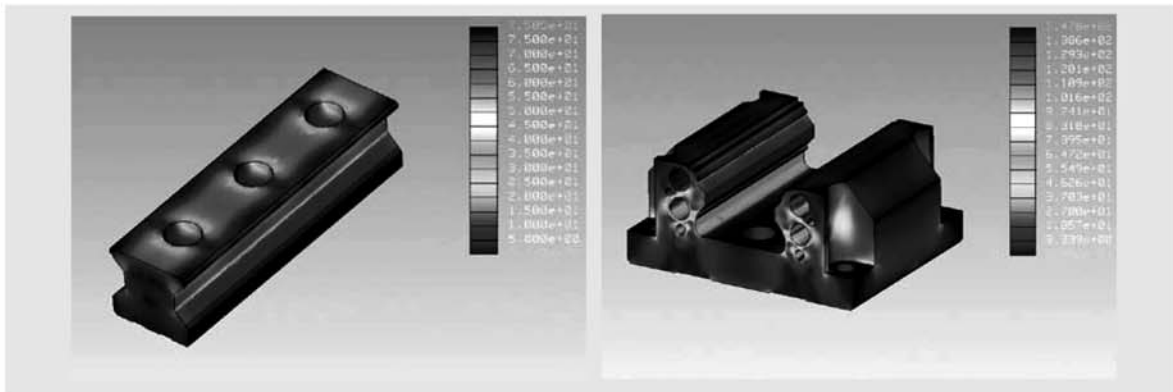

#### (2) Super high rigidity

The RG series is a type of linear guideway that uses rollers as the rolling elements. Rollers have a greater contact area than balls so that the roller guideway features higher load capacity and greater rigidity. The figure shows the rigidity of a roller and a ball with equal volume.

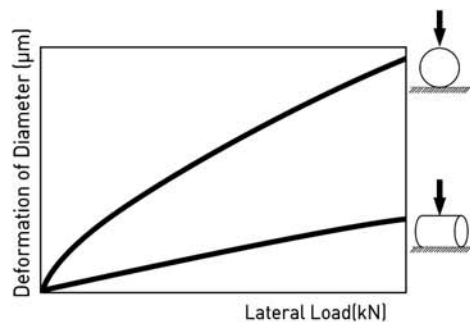

#### (3) Super high load capacity

With the four rows of rollers arranged at a contact angle of 45-degrees, the RG series linear guideway has equal load ratings in the radial, reverse radial and lateral directions. The RG series has a higher load capacity in a smaller size than conventional, ball-type linear guideways.

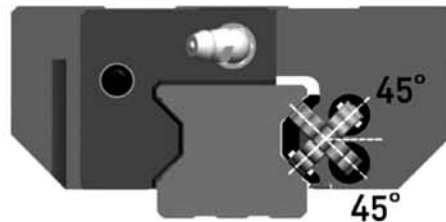

#### (4) Operating life increased

The basic dynamic load rating (100km rating) complies with ISO standard (ISO14728-1). The actual load will affect the nominal life of a linear guideway. Based on the selected basic dynamic rated load and the actual load, the nominal life can be calculated by using Eq.2.4. This life formula is different from that for conventional linear ball-type guideways.

$$L = \left( \frac{C}{P} \right)^{\frac{10}{3}} \cdot 100\text{km} = \left( \frac{C}{P} \right)^{\frac{10}{3}} \cdot 62\text{mile} \quad \dots \dots \dots \text{Eq. 2.4}$$

# Linear Guideways

## RG Series

If the environmental factors are taken into consideration, the nominal life will be influenced greatly by the motion conditions, the hardness of the raceway, and the temperature of the linear guideway. The relationship between these factors is expressed in Eq.2.5.

$$L = \left( \frac{f_h \cdot f_t \cdot C}{f_w \cdot P} \right)^{\frac{10}{3}} \cdot 100\text{km} = \left( \frac{f_h \cdot f_t \cdot C}{f_w \cdot P} \right)^{\frac{10}{3}} \cdot 62\text{mile} \quad \dots\dots\dots \text{Eq. 2.5}$$

- L : Nominal life
- P : Calculated load
- C : Basic dynamic load rating
- $f_h$  : Hardness factor
- $f_t$  : Temperature factor
- $f_w$  : Load factor

Where, the hardness factor, the temperature factor and the load factor are the same as a ball-type guideway. Compared with conventional linear ball-type guideways, the RG series linear guideway has a higher load capacity that allows it to achieve a longer service life.

### (5) Durability test

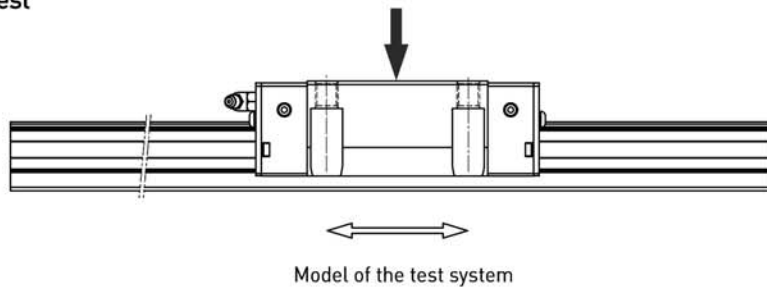



Table 2.55

<p><b>Tested model 1: RGH35CA</b>            Preload: ZA class            Max. Speed: 60m/min            Acceleration: 1G            Stroke: 0.55m            Lubrication: grease held every 100km            External: 15kN            Traveling distance: 1135km</p>	<p><b>Test results:</b>            The nominal life of the model is 1000km.            After the traveling distance, fatigue flaking did not appear on the surface of the raceway or rollers.</p> 
<p><b>Tested model 2: RGW35CC</b>            Preload: ZA class            Max. Speed: 120m/min            Acceleration: 1G            Stroke: 2m            Lubrication: oil feed rate: 0.3cm<sup>3</sup>/hr            External load: 0kN            Traveling distance: 15000km</p>	<p><b>Test results:</b>            Fatigue flaking did not appear on the surface of the raceway or rollers after a distance of (15000km).</p> 

Note: The data listed are from these samples.



## 2-4-2 Construction of RG Series

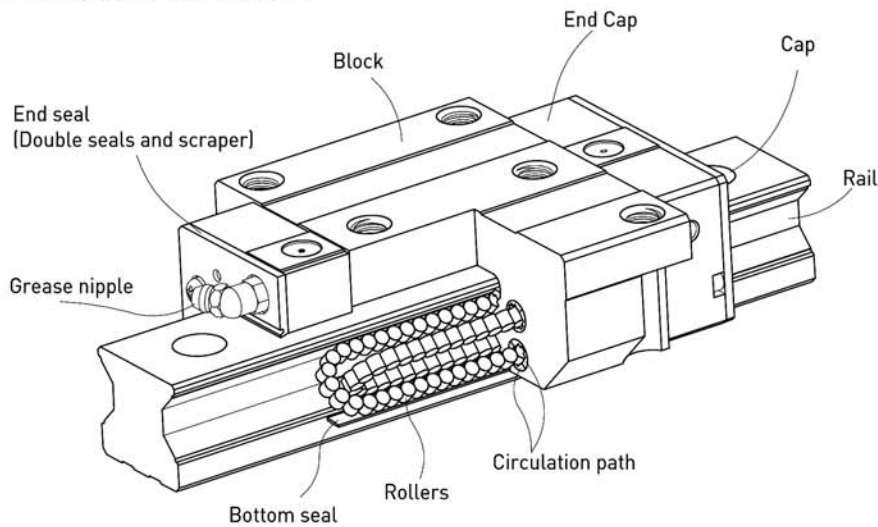

- Rolling circulation system: Block, Rail, End cap, Circulation path, rollers
- Lubrication system: Grease nipple and piping joint
- Dust protection system: End seal, Bottom seal, Cap, Double seals and Scraper

## 2-4-3 Model Number of RG series

In order to maintain H-class accuracy, the RG series linear guideway is available in only non-interchangeable types. Model numbers of the RG series contain the size, type, accuracy class, preload class, etc..

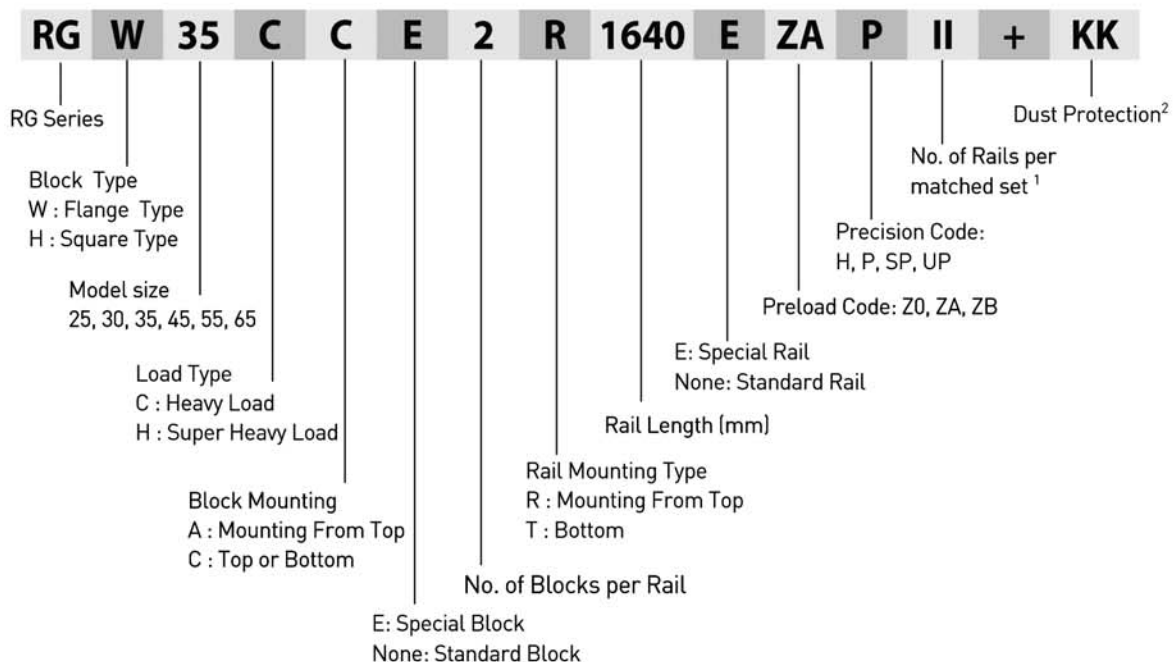

Note: 1. Roman numerals are used to express the number of matched sets of rails.

2. For dust protection, no symbol is required if it is standard (end seal and bottom seal only).

ZZ: End seal, bottom seal and scraper

KK: Double seals, bottom seal and scraper

DD: Double seals and bottom seal

# Linear Guideways

## RG Series

### 2-4-4 Types

#### (1) Block types

HIWIN offers two types of guide blocks, flange and square type. Because of the low assembly height and large mounting surface, the flange type is excellent for heavy moment load applications.

Table 2.56 Block Types

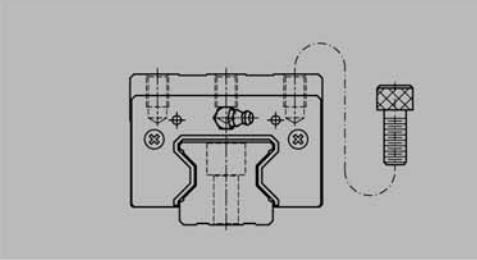
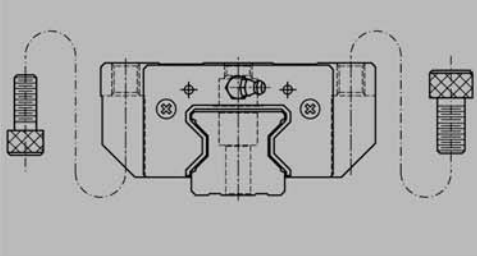
Type	Model	Shape	Height (mm)	Rail Length (mm)	Main Applications
Square	RGH-CA RGH-HA		40	100	<ul style="list-style-type: none"> <li>○ Automation Systems</li> <li>○ Transportation equipment</li> <li>○ CNC machining centers</li> <li>○ Heavy duty cutting machines</li> <li>○ CNC grinding machines</li> <li>○ Injection molding machines</li> <li>○ Plano millers</li> <li>○ Devices requiring high rigidity</li> <li>○ Devices requiring high load capacity</li> <li>○ Electric discharge machines</li> </ul>
			↓	↓	
90	4000				
↓	↓				
Flange	RGW-CC RGW-HC		36	100	
			↓	↓	
90	4000				
↓	↓				

#### (2) Rail types

In addition to the standard top mounting type, HIWIN also offers the bottom mounting type of rails.

Table 2.57 Rail Types

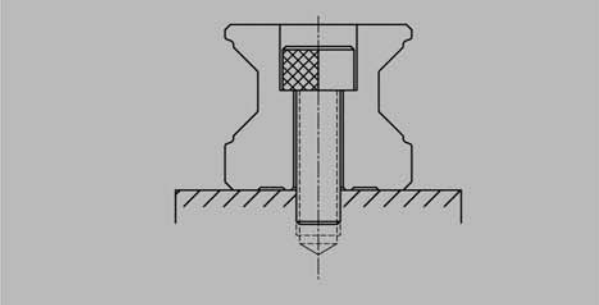
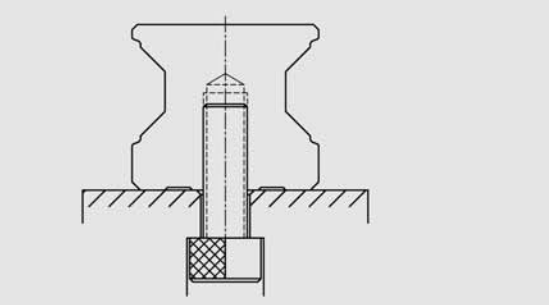
Mounting from Top	Mounting from Bottom
	

## 2-4-5 Accuracy Classes

The accuracy of the RG series can be classified into four classes: high (H), precision (P), super precision (SP) and ultra precision (UP). Customers may choose the class by referencing the accuracy requirements of the applied equipment.

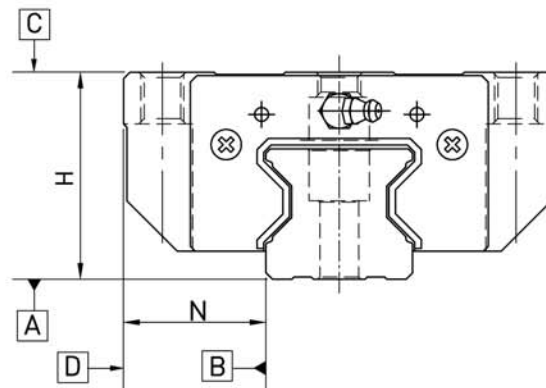

**Table 2.58 Accuracy Standards**

Unit: mm

Item	RG - 25, 30, 35			
	High (H)	Precision (P)	Super Precision (SP)	Ultra Precision (UP)
Dimensional tolerance of height H	$\pm 0.04$	0 -0.04	0 -0.02	0 -0.01
Dimensional tolerance of width N	$\pm 0.04$	0 -0.04	0 -0.02	0 -0.01
Variation of height H	0.015	0.007	0.005	0.003
Variation of width N	0.015	0.007	0.005	0.003
Running parallelism of block surface C to surface A	See Table 2.61			
Running parallelism of block surface D to surface B	See Table 2.61			

**Table 2.59 Accuracy Standards**

Unit: mm

Item	RG - 45, 55			
	High (H)	Precision (P)	Super Precision (SP)	Ultra Precision (UP)
Dimensional tolerance of height H	$\pm 0.05$	0 -0.05	0 -0.03	0 -0.02
Dimensional tolerance of width N	$\pm 0.05$	0 -0.05	0 -0.03	0 -0.02
Variation of height H	0.015	0.007	0.005	0.003
Variation of width N	0.02	0.01	0.007	0.005
Running parallelism of block surface C to surface A	See Table 2.61			
Running parallelism of block surface D to surface B	See Table 2.61			

**Table 2.60 Accuracy Standards**

Unit: mm

Item	RG - 65			
	High (H)	Precision (P)	Super Precision (SP)	Ultra Precision (UP)
Dimensional tolerance of height H	$\pm 0.07$	0 -0.07	0 -0.05	0 -0.03
Dimensional tolerance of width N	$\pm 0.07$	0 -0.07	0 -0.05	0 -0.03
Variation of height H	0.02	0.01	0.007	0.005
Variation of width N	0.025	0.015	0.01	0.007
Running parallelism of block surface C to surface A	See Table 2.61			
Running parallelism of block surface D to surface B	See Table 2.61			

# Linear Guideways

## RG Series

Table 2.61 Accuracy of Running Parallelism

Rail Length (mm)	Accuracy (µm)			
	H	P	SP	UP
~ 100	7	3	2	2
100 ~ 200	9	4	2	2
200 ~ 300	10	5	3	2
300 ~ 500	12	6	3	2
500 ~ 700	13	7	4	2
700 ~ 900	15	8	5	3
900 ~ 1,100	16	9	6	3
1,100 ~ 1,500	18	11	7	4
1,500 ~ 1,900	20	13	8	4
1,900 ~ 2,500	22	15	10	5
2,500 ~ 3,100	25	18	11	6
3,100 ~ 3,600	27	20	14	7
3,600 ~ 4,000	28	21	15	7

### 2-4-6 Preload

A preload can be applied to each guideway using oversized rollers. Generally, a linear motion guideway has negative clearance between the raceway and rollers to improve stiffness and maintain high precision. The RG series linear guideway offers three standard preloads for various applications and conditions.

Table 2.62

Class	Code	Preload	Condition
Light Preload	Z0	0.02C~0.04C	Certain load direction, low impact, low precision required
Medium Preload	ZA	0.07C~0.09C	High rigidity required, high precision required
Heavy Preload	ZB	0.12C~0.14C	Super high rigidity required, with vibration and impact

The figure shows the relationship between the rigidity, friction and nominal life. A preload no larger than ZA would be recommended for smaller model sizes to avoid over-preload affecting the life of the guideway.

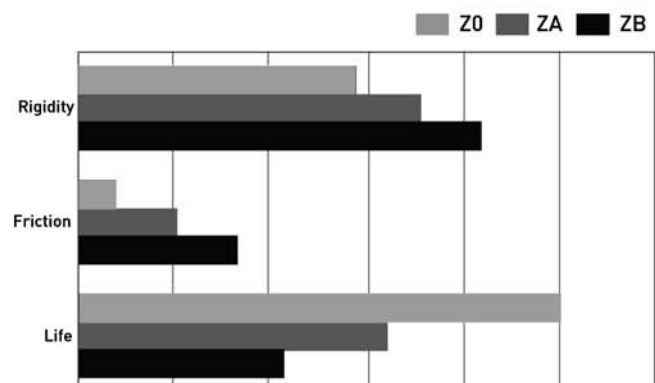

## 2-4-7 Lubrication

The standard location of the grease fitting is at both ends of the block, but the nipple can be mounted in the side or the top of block. For lateral installation, we recommend that the nipple be mounted at the non-reference side, otherwise please contact us. It is possible to carry out the lubrication by using an oil-piping joint. The figure shows the locations of the grease fitting.

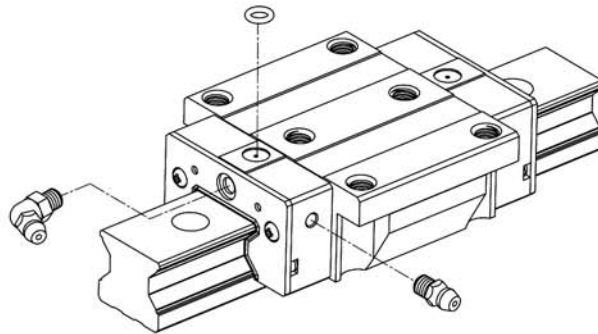

## 2-4-8 Dust Proof Accessories

### (1) Codes of accessories

If the following accessories are needed, please add the code followed by the model number.

Table 2.63

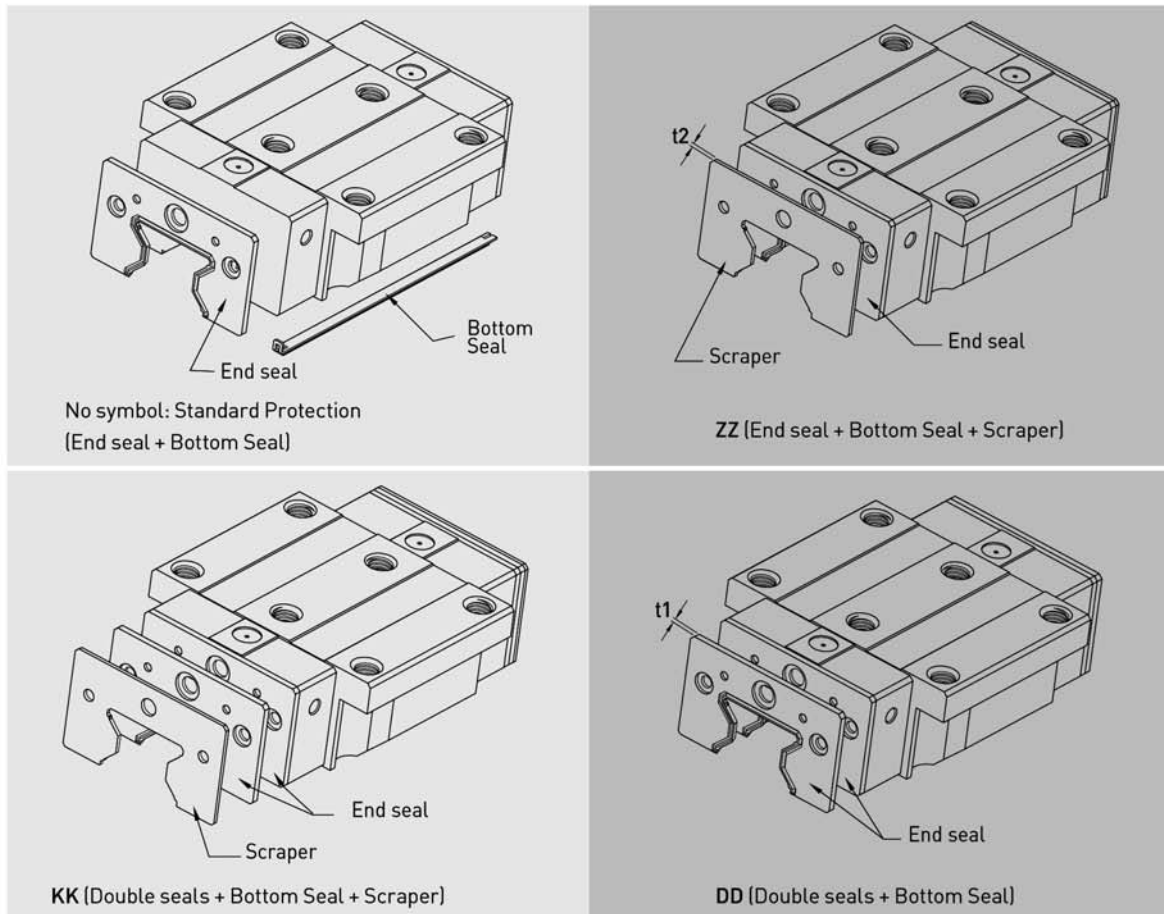

### (2) End seal and bottom seal

To prevent life reduction caused by iron chips or dust entering the block.

# Linear Guideways

## RG Series

### (3) Double seals

Enhances the wiping effect, foreign matter can be completely wiped off.

**Table 2.64 Dimensions of end seal**

Size	Thickness (t1) (mm)	Size	Thickness (t1) (mm)
RG 25 ES	2.2	RG 45 ES	3.6
RG 30 ES	2.4	RG 55 ES	3.6
RG 35 ES	2.5	RG 65 ES	4.4

### (4) Scraper

The scraper removes high-temperature iron chips and larger foreign objects.

**Table 2.65 Dimensions of scraper**

Size	Thickness (t2) (mm)	Size	Thickness (t2) (mm)
RG 25 SC	1.0	RG 45 SC	1.5
RG 30 SC	1.5	RG 55 SC	1.5
RG 35 SC	1.5	RG 65 SC	1.5

### (5) Bolt caps for rail mounting holes

Caps are used to cover the mounting holes to prevent chips or other foreign objects from collecting in the holes. The caps will be enclosed in each rail package.



**Table 2.66 Dimensions of Bolt Caps for Rail Mounting Holes**

Rail size	Bolt size	Diameter(D) (mm)	Thickness(H) (mm)	Rail size	Bolt size	Diameter(D) (mm)	Thickness(H) (mm)
RGR25	M6	11.3	2.5	RGR45	M12	20.3	4.6
RGR30	M8	14.3	3.3	RGR55	M14	23.5	5.5
RGR35	M8	14.3	3.3	RGR65	M16	26.6	5.5

## 2-4-9 Friction

The maximum value of resistance per end seal are as shown in the table.

**Table 2.67 Seal Resistance**

Size	Resistance (kgf)	Size	Resistance (kgf)
RG25	0.28	RG45	0.43
RG30	0.31	RG55	0.52
RG35	0.36	RG65	0.68

## 2-4-10 The Accuracy Tolerance of Mounting Surface

### (1) The accuracy tolerance of rail-mounting surface

As long as the accuracy requirements of the mounting surfaces shown in the following tables are met, the high accuracy, high rigidity and long life of the RG series linear guideway will be maintained without any difficulty.

#### ○ The parallelism tolerance of reference surface (P)

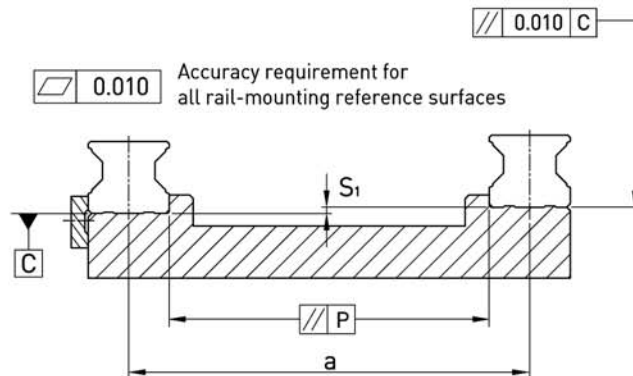

Table 2.68 Max. Parallelism Tolerance (P)

unit:  $\mu\text{m}$

Size	Preload classes		
	Light Preload (Z0)	Medium Preload (ZA)	Heavy Preload (ZB)
RG25	9	7	5
RG30	11	8	6
RG35	14	10	7
RG45	17	13	9
RG55	21	14	11
RG65	27	18	14

#### ○ The accuracy tolerance of reference surface height ( $S_1$ )

$$S_1 = a \times K$$

$S_1$  : Max. tolerance of height

$a$  : Distance between paired rails

$K$  : Coefficient of tolerance of height

Table 2.69 Coefficient of tolerance of height

Size	Preload classes		
	Light Preload (Z0)	Medium Preload (ZA)	Heavy Preload (ZB)
K	$2.2 \times 10^{-4}$	$1.7 \times 10^{-4}$	$1.2 \times 10^{-4}$

# Linear Guideways

## RG Series

### [2] The accuracy tolerance of block-mounting surface

- The tolerance of the height of reference surface when two or more pieces are used in parallel ( $S_2$ )

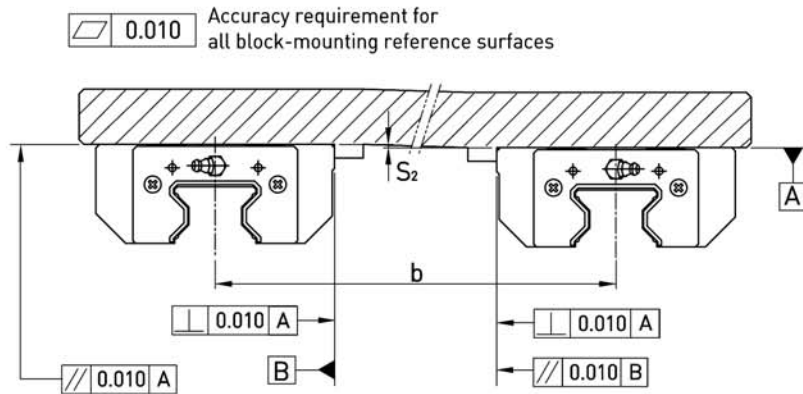

$$S_2 = b \times 4.2 \times 10^{-5}$$

$S_2$  : Max. tolerance of height  
 $b$  : Distance between paired blocks

- The tolerance of the height of reference surface when two or more pieces are used in parallel ( $S_3$ )

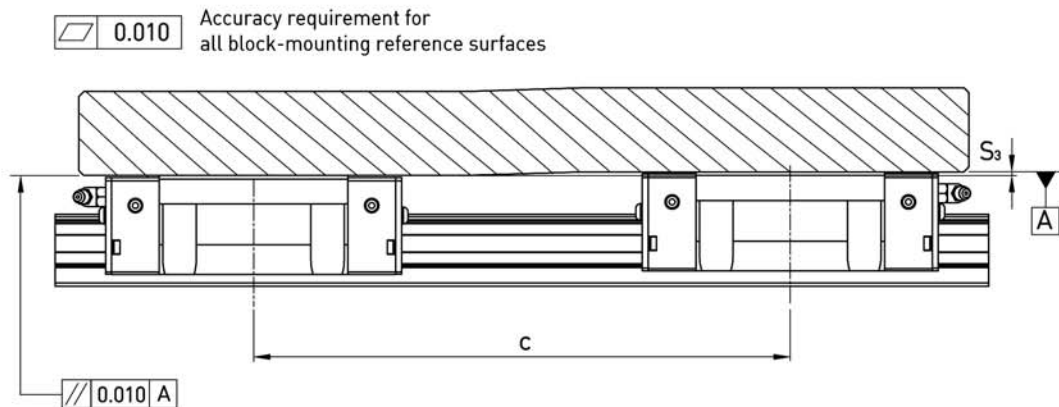

$$S_3 = c \times 4.2 \times 10^{-5}$$

$S_3$  : Max. tolerance of height  
 $c$  : Distance between paired blocks



## 2-4-11 Cautions for Installation

### (1) Shoulder heights and fillets

Improper shoulder heights and fillets of mounting surfaces will cause a deviation in accuracy and interference with the chamfered part of the rail or block.

By following the recommended shoulder heights and fillets, accuracy problems in installation can be eliminated.

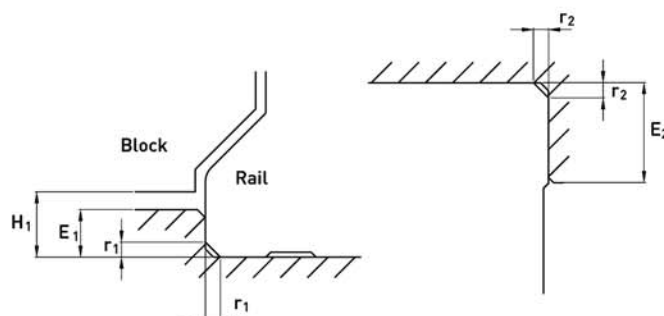

Table 2.70

Size	Max. radius of fillets $r_1$ (mm)	Max. radius of fillets $r_2$ (mm)	Shoulder height of the rail $E_1$ (mm)	Shoulder height of the block $E_2$ (mm)	Clearance under block $H_1$ (mm)
RG25	1.0	1.0	5	5	5.5
RG30	1.0	1.0	5	5	6
RG35	1.0	1.0	6	6	6.5
RG45	1.0	1.0	7	8	8
RG55	1.5	1.5	9	10	10
RG65	1.5	1.5	10	10	12

### (2) Tightening Torque of Mounting Bolts

Improper tightening of mounting bolts will seriously influence the accuracy of a linear guideway. The following tightening torque for the different sizes of bolt is recommended.

Table 2.71

Size	Bolt size	Torque N-cm (kgf-cm)
RG25	M6×1P×20L	1373 (140)
RG30	M8×1.25P×25L	3041 (310)
RG35	M8×1.25P×25L	3041 (310)
RG45	M12×1.75P×35L	11772 (1200)
RG55	M14×2P×45L	15696 (1600)
RG65	M16×2P×50L	19620 (2000)

# Linear Guideways

## RG Series

### 2-4-12 Standard and Maximum Lengths of Rail

HIWIN offers a number of standard rail lengths. Standard rail lengths feature end mounting hole placements set to predetermined values (E). For non-standard rail lengths, be sure to specify the E-value to be no greater than 1/2 the pitch (P) dimension. An E-value greater than this will result in unstable rail ends.

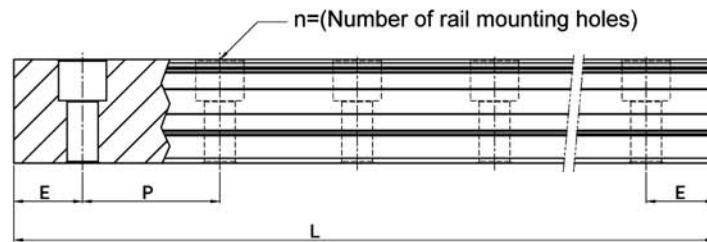

Table 2.72

unit: mm

Item	RGR25	RGR30	RGR35	RGR45	RGR55	RGR65
Standard Length L(n)	220(7)	280(7)	280(7)	570(11)	780(13)	1,270(17)
	280(9)	440(11)	440(11)	885(17)	1020(17)	1,570(21)
	340(11)	600(15)	600(15)	1,200(23)	1,260(21)	2,020(27)
	460(15)	760(19)	760(19)	1,620(31)	1,500(25)	2,620(35)
	640(21)	1,000(25)	1,000(25)	2,040(39)	1,980(33)	-
	820(27)	1,640(41)	1,640(41)	2,460(47)	2,580(43)	-
	1,000(33)	2,040(51)	2,040(51)	2,985(57)	2,940(49)	-
	1,240(41)	2,520(63)	2,520(63)	3,090(59)	3,060(51)	-
	1,600(53)	3,000(75)	3,000(75)	-	-	-
Pitch (P)	30	40	40	52.5	60	75
Distance to End (E <sub>1</sub> )	20	20	20	22.5	30	35
Max. Standard Length	4,000(133)	3,960(99)	3,960(99)	3,930(75)	3,900(65)	3,970(53)
Max. Length	4,000	4,000	4,000	4,000	4,000	4,000

- Note :
1. Tolerance of E value for standard rail is 0.5--0.5 mm. Tolerance of E value for jointed rail is 0--0.3 mm.
  2. Maximum standard length means the max. rail length with standard E value on both sides.
  3. If different E value is needed, please contact HIWIN.

## 2-4-13 Dimensions for RG series

### (1) RGH-CA / RGH-HA

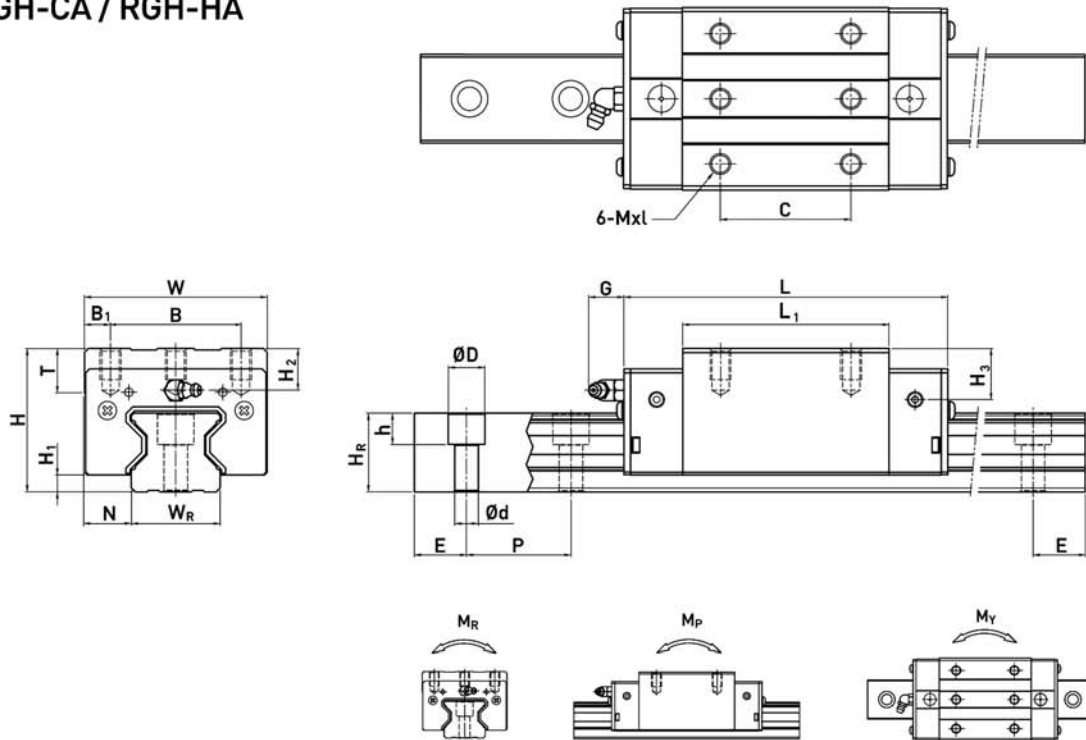

Model No.	Dimensions of Assembly (mm)		Dimensions of Block (mm)										Dimensions of Rail (mm)					Mounting Bolt for Rail (mm)	Basic Dynamic Load Rating C <sub>0</sub> (kN)	Basic Static Load Rating C <sub>0</sub> (kN)	Static Rated Moment			Weight						
	H	H <sub>1</sub>	N	W	B	B <sub>1</sub>	C	L <sub>1</sub>	L	G	Mxl	T	H <sub>2</sub>	H <sub>3</sub>	W <sub>R</sub>	H <sub>R</sub>	D				h	d	P	E	M <sub>R</sub>	M <sub>P</sub>	M <sub>Y</sub>	Block	Rail	
	kgf	mm	mm	mm	mm	mm	mm	mm	mm	mm	mm	mm	mm	mm	mm	mm	mm	mm	mm	mm	mm	mm	kN-m	kN-m	kN-m	kg	kg/m			
RGH 25CA	40	5.5	12.5	48	35	6.5	35	64.5	97.9		12	M6x8	9.5	10.2	10	23	23.6	11	9	7	30	20	M6x20	27.7	57.1	0.758	0.605	0.605	0.55	3.08
RGH 25HA							50	81	114.4														33.9	73.4	0.975	0.991	0.991	0.7		
RGH 30CA	45	6	16	60	40	10	40	71	109.8		12	M8x10	9.5	9.5	13.8	28	28	14	12	9	40	20	M8x25	39.1	82.1	1.445	1.06	1.06	0.82	4.41
RGH 30HA							60	93	131.8														48.1	105	1.846	1.712	1.712	1.07		
RGH 35CA	55	6.5	18	70	50	10	50	79	124		12	M8x12	12	16	19.6	34	30.2	14	12	9	40	20	M8x25	57.9	105.2	2.17	1.44	1.44	1.43	6.06
RGH 35HA							72	106.5	151.5														73.1	142	2.93	2.6	2.6	1.86		
RGH 45CA	70	8	20.5	86	60	13	60	106	153.2		12.9	M10x17	16	20	24	45	38	20	17	14	52.5	22.5	M12x35	92.6	178.8	4.52	3.05	3.05	2.97	9.97
RGH 45HA							80	139.8	187														116	230.9	6.33	5.47	5.47	3.97		
RGH 55CA	80	10	23.5	100	75	12.5	75	125.5	183.7		12.9	M12x18	17.5	22	27.5	53	44	23	20	16	60	30	M14x45	130.5	252	8.01	5.4	5.4	4.62	13.98
RGH 55HA							95	173.8	232														167.8	348	11.15	10.25	10.25	6.4		
RGH 65CA	90	12	31.5	126	76	25	70	160	232		12.9	M16x20	25	15	15	63	53	26	22	18	75	35	M16x50	213	411.6	16.20	11.59	11.59	8.33	20.22
RGH 65HA							120	223	295														275.3	572.7	22.55	22.17	22.17	11.62		

Note : 1 kgf = 9.81 N

# Linear Guideways

## RG Series

### (2) RGW-CC / RGW-HC

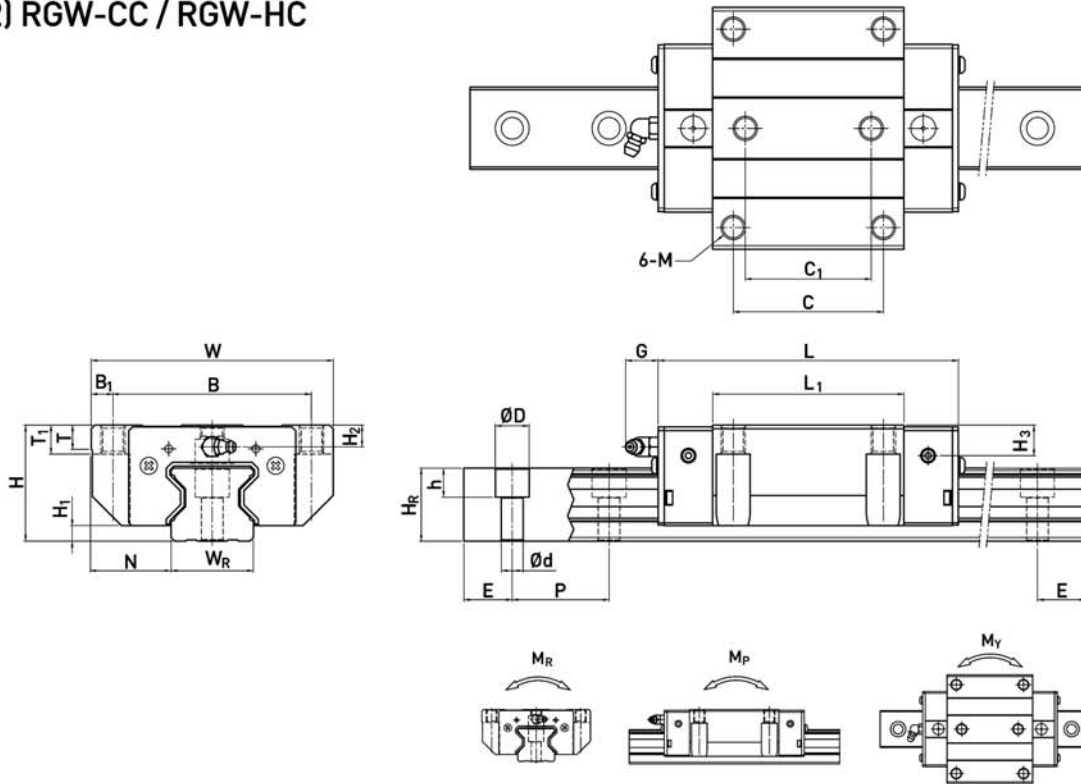

Model No.	Dimensions of Assembly (mm)		Dimensions of Block (mm)													Dimensions of Rail (mm)						Mounting Bolt for Rail (mm)	Basic Dynamic Load Rating C (kN)	Basic Static Load Rating C <sub>0</sub> (kN)	Static Rated Moment			Weight					
	H	H <sub>1</sub>	N	W	B	B <sub>1</sub>	C	C <sub>1</sub>	L <sub>1</sub>	L	G	M	T	T <sub>1</sub>	H <sub>2</sub>	H <sub>3</sub>	W <sub>R</sub>	H <sub>R</sub>	D	h	d				P	E	M <sub>R</sub>	M <sub>P</sub>	M <sub>Y</sub>	Block	Rail		
	kg	kg/m	kg	kg	kg	kg	kg	kg	kg	kg	kg	kg	kg	kg	kg	kg	kg	kg	kg	kg	kg				kg	kg	kg	kg	kg	kg	kg	kg	
RGW 25CC	36	5.5	23.5	70	57	6.5	45	40	64.5	97.9	12	M8	9.5	10	6.2	6	23	23.6	11	9	7	30	20	M6x20	27.7	57.1	0.758	0.605	0.605	0.67	3.08		
RGW 25HC									81	114.4																							
RGW 30CC	42	6	31	90	72	9	52	44	71	109.8	12	M10	9.5	10	6.5	10.8	28	28	14	12	9	40	20	M8x25	39.1	82.1	1.445	1.06	1.06	1.06	4.41		
RGW 30HC									93	131.8																							
RGW 35CC	48	6.5	33	100	82	9	62	52	79	124	12	M10	12	13	9	12.6	34	30.2	14	12	9	40	20	M8x25	57.9	105.2	2.17	1.44	1.44	1.61	6.06		
RGW 35HC									106.5	151.5																							
RGW 45CC	60	8	37.5	120	100	10	80	60	106	153.2	12.9	M12	14	15	10	14	45	38	20	17	14	52.5	22.5	M12x35	92.6	178.8	4.52	3.05	3.05	3.22	9.97		
RGW 45HC									139.8	187																							
RGW 55CC	70	10	43.5	140	116	12	95	70	125.5	183.7	12.9	M14	16	17	12	17.5	53	44	23	20	16	60	30	M14x45	130.5	252	8.01	5.4	5.4	5.18	13.98		
RGW 55HC									173.8	232																							
RGW 65CC	90	12	53.5	170	142	14	110	82	160	232	12.9	M16	22	23	15	15	63	53	26	22	18	75	35	M16x50	213	411.6	16.20	11.59	11.59	11.04	20.22		
RGW 65HC									223	295																							

Note : 1 kgf = 9.81 N

### (3) Dimensions for RGR-T (Rail Mounting from Bottom)

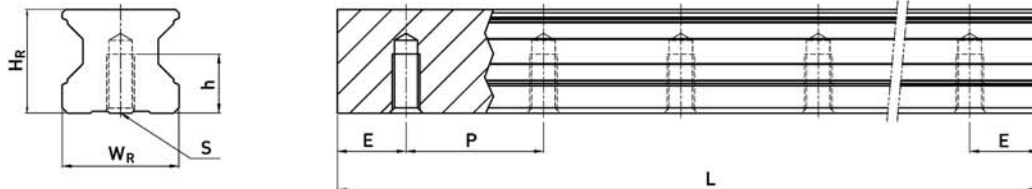

Model No.	Dimensions of Rail (mm)						Weight (kg/m)
	$W_R$	$H_R$	S	h	P	E	
RGR25T	23	23.6	M6×1P	12	30	20	3.36
RGR30T	28	28	M8×1.25P	15	40	20	4.82
RGR35T	34	30.2	M8×1.25P	17	40	20	6.48
RGR45T	45	38	M12×1.75P	24	52.5	22.5	10.83
RGR55T	53	44	M14×2P	24	60	30	15.15
RGR65T	63	53	M20×2.5P	30	75	35	21.24

# Linear Guideways

## E2 Type

### 2-5 E2 Type - Self lubrication Kit for Linear Guideways

#### 2-5-1 Construction of E2 Type

E2 self-lubricating linear guideway contains a lubricator between the end cap and end seal, the outer side of block is equipped with a replaceable oil cartridge, the configuration of which is listed below.

Lubrication oil flows to the lubricator from the replaceable oil cartridge and then lubricates grooves of rails. The Oil cartridge comprises a oil conductor with 3D structure that enables the lubricator to contact oil despite that blocks are placed at a random position or oil flow becomes less, and thus the lubrication oil inside the oil cartridge can be used up via capillary action.

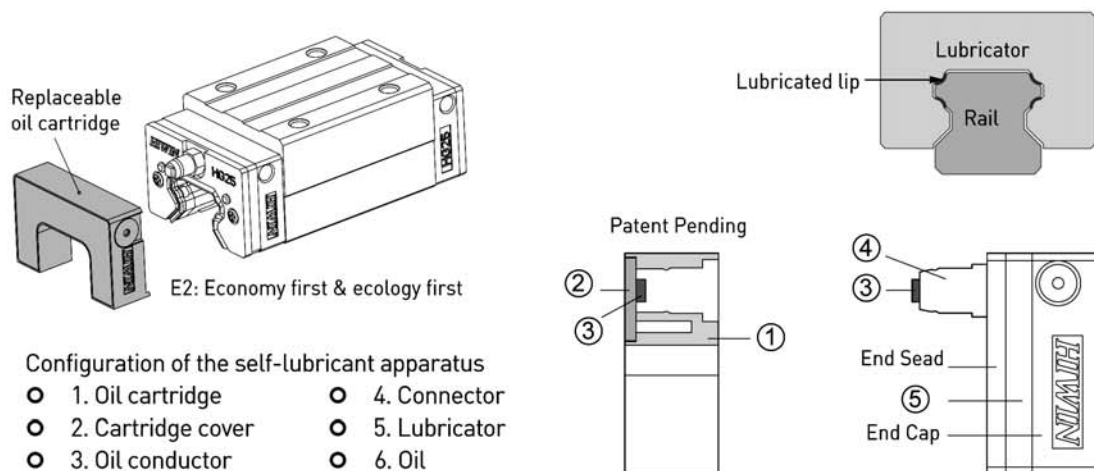

#### 2-5-2 Feature of E2 Type

(1) Cost reduction: Save costs by reducing oil usage and maintenance.

Table 2.73

Item	Standard Block	E2 (Self-lubricant) Block
Lubricant device	\$ XXX	-
Design and installation of lubricant device	\$ XXX	-
Cost of oil purchase	0.3cc / hr x 8hrs / day x 280 days / year x 5 year = 3360 cc x cost / cc = \$ XXX	10 cc(5 years10000km) x cost/cc = \$ XX
Cost of refillin	3-5hrs / time x 3-5times / year x 5year x cost / time = \$ XXX	-
Waste oil disposal	3-5 times / year x 5year x cost / time = \$ XXX	-

(2) Clean and environmentally friendly: Optimized oil usage prevents leaking, making it the ideal solution for clean working environments.

(3) Long last and low maintenance: Self-lubricating block is maintenance free in most applications.

(4) No installation limitations: The linear guideway can be lubricated by E2 self-lubricating module irrespective of mounting directions.

(5) Easy to be assembled and dismantled: The cartridge can be added or removed from the block even when the guideway is installed on a machine.

(6) Different oils can be selected: The replaceable oil cartridge can be refilled with any approved lubrication oil depending on different requirements.

(7) Applications for special environments: Sealing grease into the block leads to better lubrication effects especially in dusty, dirty, or wet environments.

## 2-5-3 Applications

- (1) Machine tools
- (2) Manufacturing Machines : Plastic injection, printing, paper making, textile machines, food processing machines, wood working machines, and so on.
- (3) Electronic Machinery : Semiconductor equipment, robotics, X-Y table, measuring and inspecting equipment.
- (4) Others : Medical equipment, transporting equipment, construction equipment.

## 2-5-4 Specification

- (1) Add "/ E2" after the specification of linear guideway  
Ex. HGW25CC2R1600ZAPII + ZZ / E2

## 2-5-5 Lubrication Capability

- (1) Life testing with light load

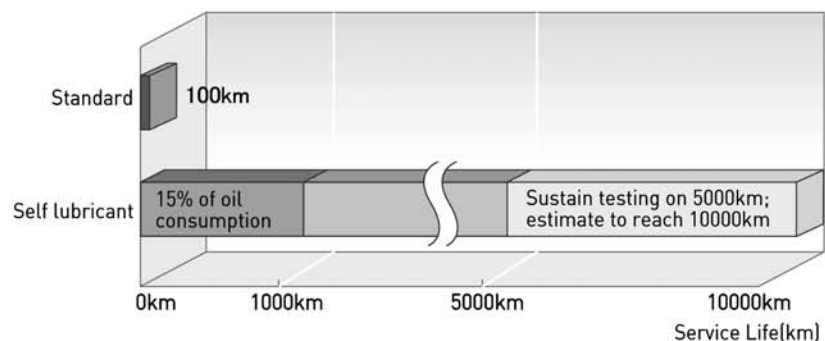

Table 2.74 Test condition

Model No.	HGW25CC
Speed	60m / min
Stroke	1500mm
Load	500kgf

### (2) Characteristic of lubricant oil

The standard oil filled in the oil cartridge is Mobil SHC 636, which is a fully synthetic lubricant with a main constituent, synthetic hydrocarbons (PAO). The viscosity class of the oil is 680 (ISO VG 680). Its characteristics are as follows.

- Compatible with lubrication grease of which the base oil is synthetic hydrocarbon oil, mineral oil or ester oil.
- Synthetic oil with superb high temperature thermal/oxidation resistance.
- High viscosity index to provide outstanding performance in service applications at extremely high and low temperatures.
- Low traction coefficient to reduce power consumption.
- Anti-corrosion and rust-proof.

- \* Lubricants with the same viscosity class can also be used; however, their compatibility should be taken into consideration.

## 2-5-6 Temperature Range for Application

The application temperature for this product is  $-10^{\circ}\text{C} \sim 60^{\circ}\text{C}$ . Please contact with HIWIN for further discussion and information if the temperature is out of this range.

# Linear Guideways

## E2 Type

### 2-5-7 Assembling and Dismantling of Oil Cartridge

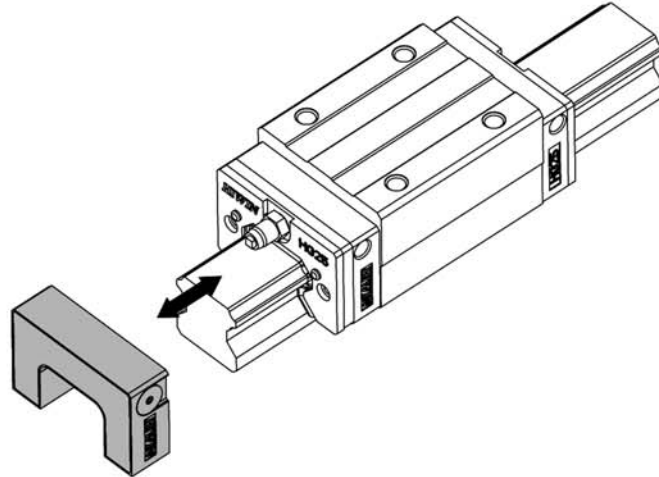

### 2-5-8 Dimension Table for E2 Type

(1) HG Series

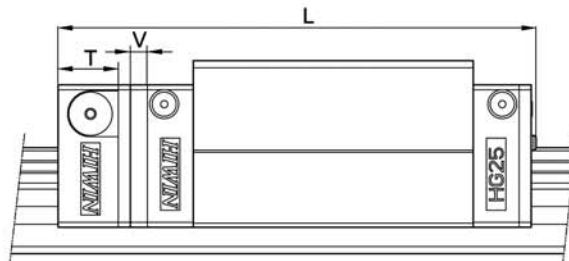
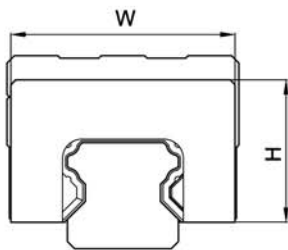

Model No.	E2 self-lubricating module dimensions					
	W	H	T	V	L	
HG 15 C	32.4	19.5	12.5	3	75.4	
HG 20 C	43	24.4	13.5	3.5	93.6	
HG 20 H	43	24.4	13.5	3.5	108.3	
HG 25 C	46.4	29.5	13.5	3.5	100.5	
HG 25 H	46.4	29.5	13.5	3.5	121.1	
HG 30 C	58	35	13.5	3.5	112.9	
HG 30 H	58	35	13.5	3.5	135.9	
HG 35 C	68	38.5	13.5	3.5	127.9	
HG 35 H	68	38.5	13.5	3.5	153.7	
HG 45 C	82	49	16	4.5	157.2	
HG 45 H	82	49	16	4.5	189	
HG 55 C	97	55.5	16	4.5	183.9	
HG 55 H	97	55.5	16	4.5	222	
HG 65 C	121	69	16	4.5	219.7	
HG 65 H	121	69	16	4.5	279.1	



(2) EG Series

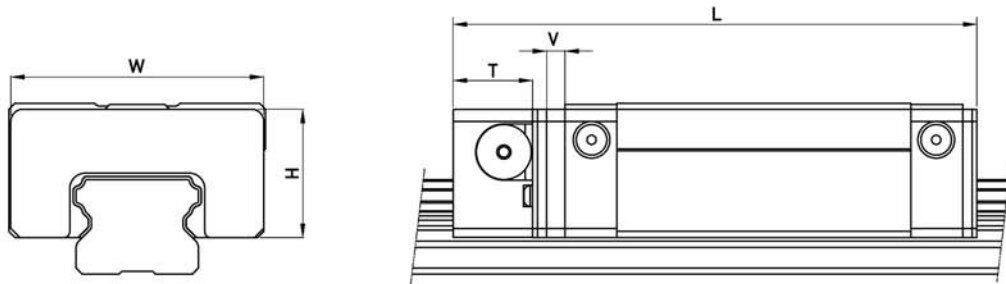

Model No.	E2 self-lubricating module dimensions				
	W	H	T	V	L
EG 15 S	33.3	18.7	11.5	3	54.6
EG 15 C					71.3
EG 20 S	41.3	20.9	13	3	66
EG 20 C					85.1
EG 25 S	47.3	24.9	13	3	75.1
EG 25 C					98.6
EG 30 S	59.3	31	13	3	85.5
EG 30 C					114.1

(3) RG Series

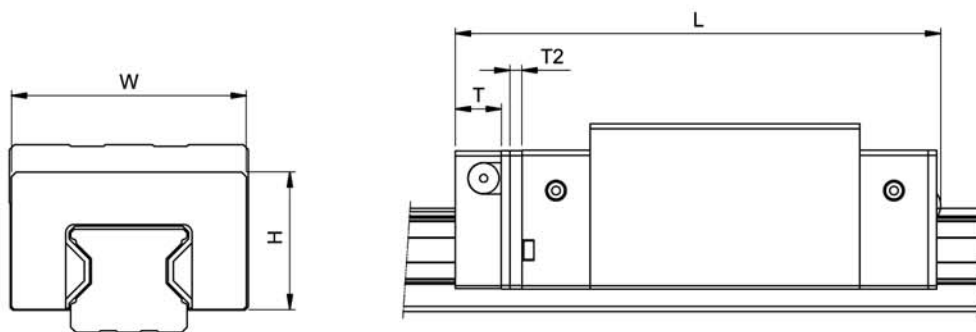

Model No.	E2 self-lubricating module dimensions				
	W	H	T	V	L
RG 25 C	46.8	29.2	13.5	3.5	114.9
RG 25 H					131.4
RG 30 C	58.8	34.9	13.5	3.5	127.0
RG 30 H					149.0
RG 35 C	68.8	40.3	13.5	3.5	141.0
RG 35 H					168.5
RG 45 C	83.8	50.2	16	4.5	173.7
RG 45 H					207.5
RG 55 C	97.6	58.4	16	4.5	204.2
RG 55 H					252.5

# Linear Guideways

## PG Type

### 2-6 PG Type - Positioning Guideway

#### [1] Construction of PG Type

IG is a Linear Guideway assembly integrated with a position measurement magnetic encoder.

#### [2] HIWIN PG Features

1. The additional components are completely internal, thus saving installation space.
2. Maintains high rigidity as well as high accuracy.
3. Both sensor and magnetic strip are protected from externally harmful contaminants such as dust, iron chips, etc.
4. Non-contact measuring sensor can achieve longer life.
5. Can measure distances up to 30 m.
6. Can withstand humid, and high-temperature environments in oily, dusty, and high vibration applications.
7. High resolution
8. Easy to install

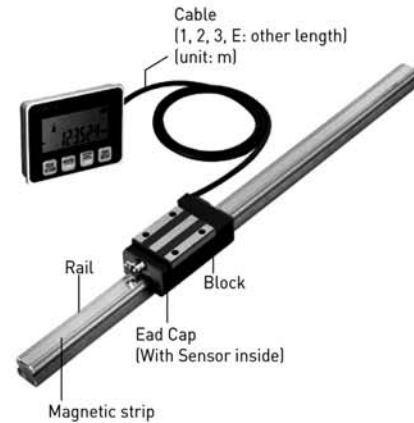

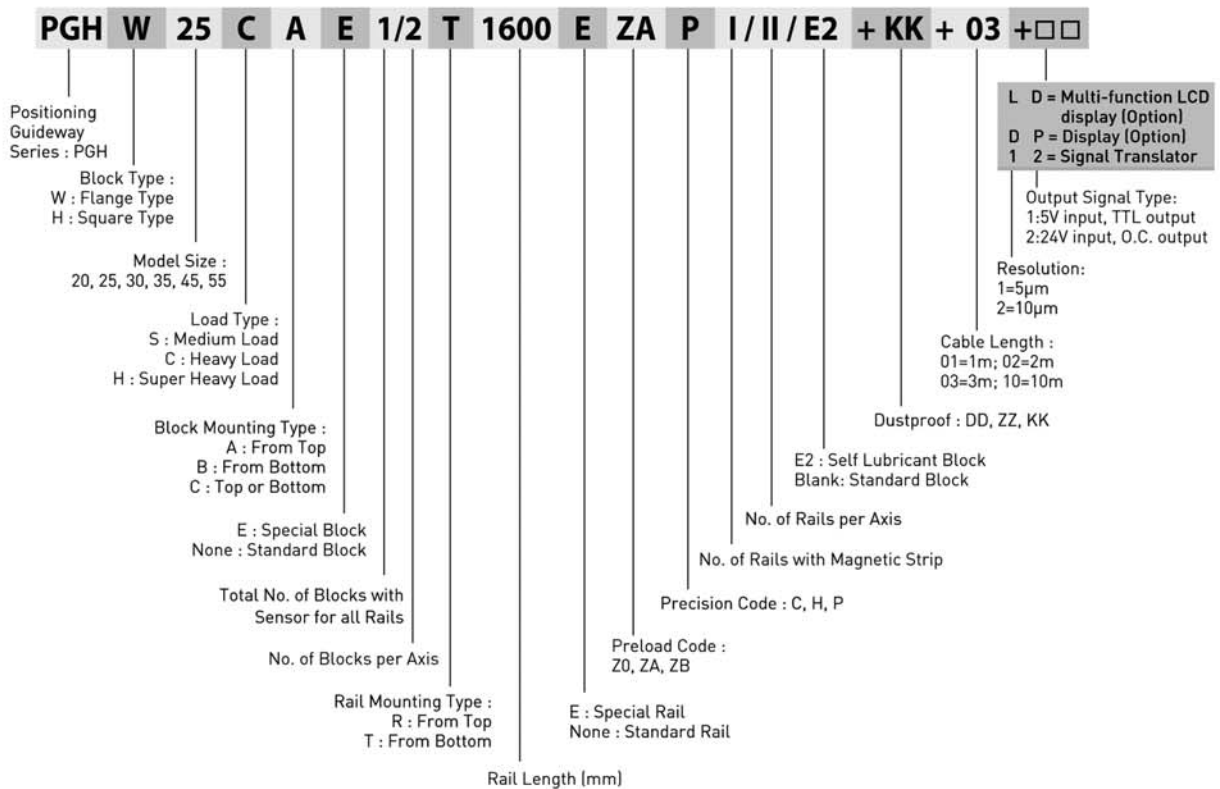

#### 2-6-1 Model Number of PG Type



## 2-6-2 Technical Data of PG Type

Table 2.75

Specifications			
Item			
	Signal Translator	Display	Multi-function LCD Display
Measuring length	Max. 10M (option: Max. 30M)	Max. 10M (option: Max. 30M)	Max. 10M (option: Max. 30M)
Resolution (μm)	5/10	5	5
Accuracy (μm)	± (80+15×L), L: Scale length unit(m)	± (80+15×L), L: Scale length unit(m)	± (80+15×L), L: Scale length unit(m)
Repeatability (μm)	±10 μ / m	±10 μ / m	±10 μ / m
Max. velocity (m/sec)	1.2 (Acc. 1G)	3 (Acc. 2G)	3 (Acc. 2G)
Output pulse signals	A, B phase differential , O.C	-	-
Max. output frequency (KHZ)	64/32 (at resolution: 5/10μm)	-	-
Power input	DC5V ±5% / 1A	DC5V ±5% / 1A	Commercial AA battery x 2
Battery life		-	1 year (when set at 1.5m/s)
Operating temperature(°C)	0 ~ 50	0 ~ 50	0 ~ 50
Storage temperature(°C)	-5 ~ 70	-5 ~ 70	-5 ~ 70
IP Class	Scale / Sensor: IP66, Display : IP43	Scale / Sensor: IP66, Display : IP43	Scale / Sensor: IP66, Display : IP43

# Linear Guideways

## PG Type

### Signal Translator

► D-type 9 pin layout:

Pin1 = 0V

Pin2 = 5V/DC

Pin3 = channel A

Pin4 = channel B

Pin7 = channel  $\bar{B}$

Pin8 = channel  $\bar{A}$

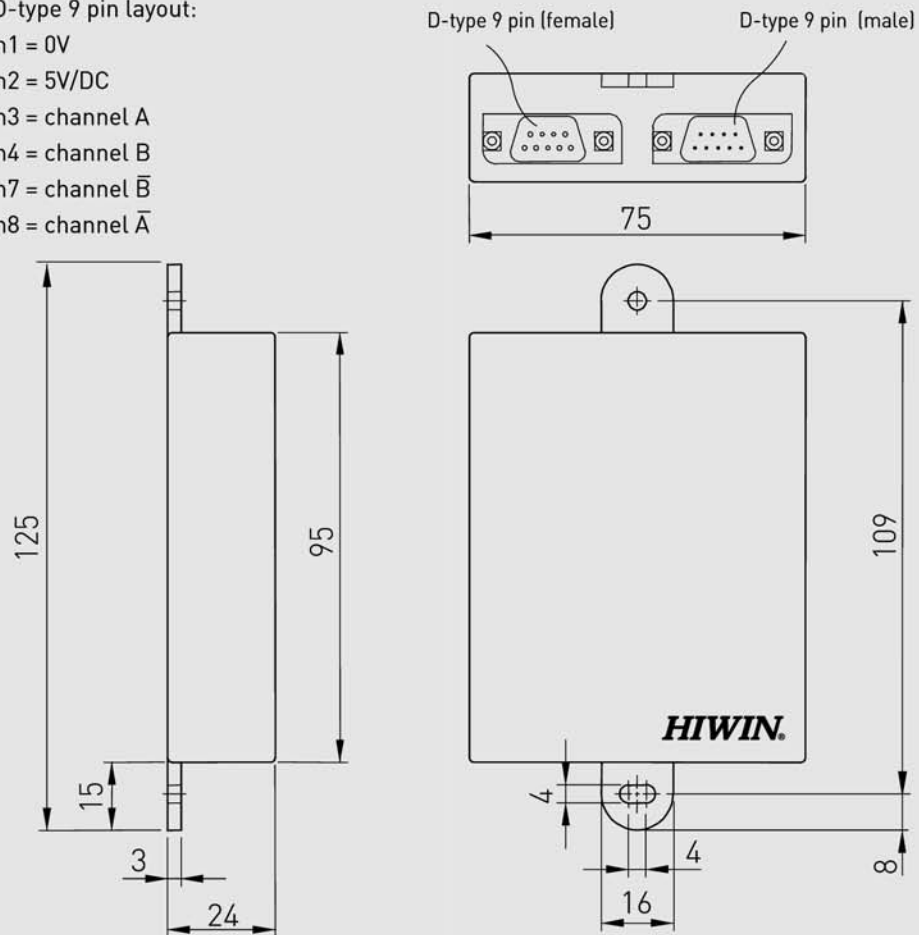

### Display

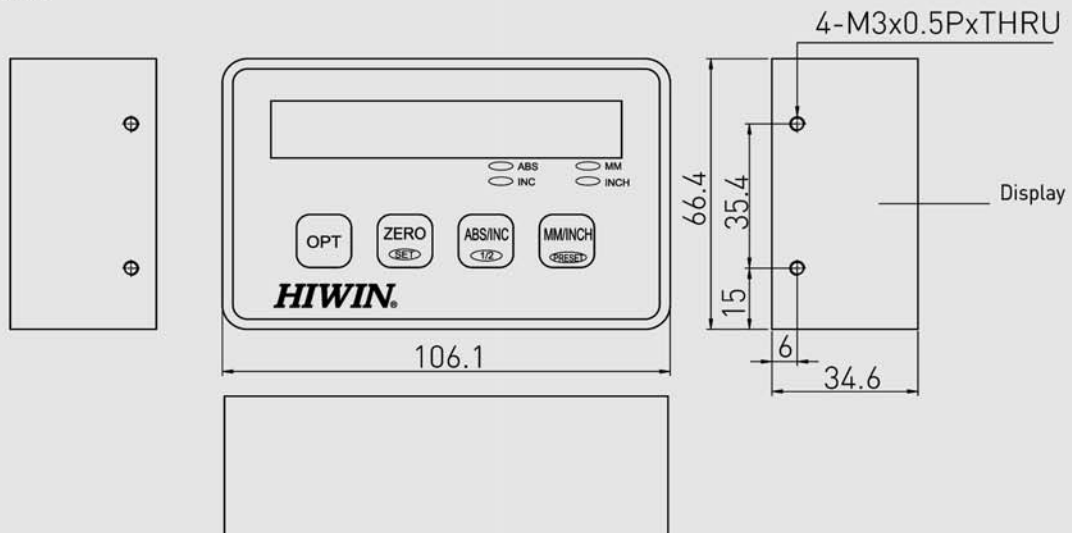

## Multi-function LCD Display

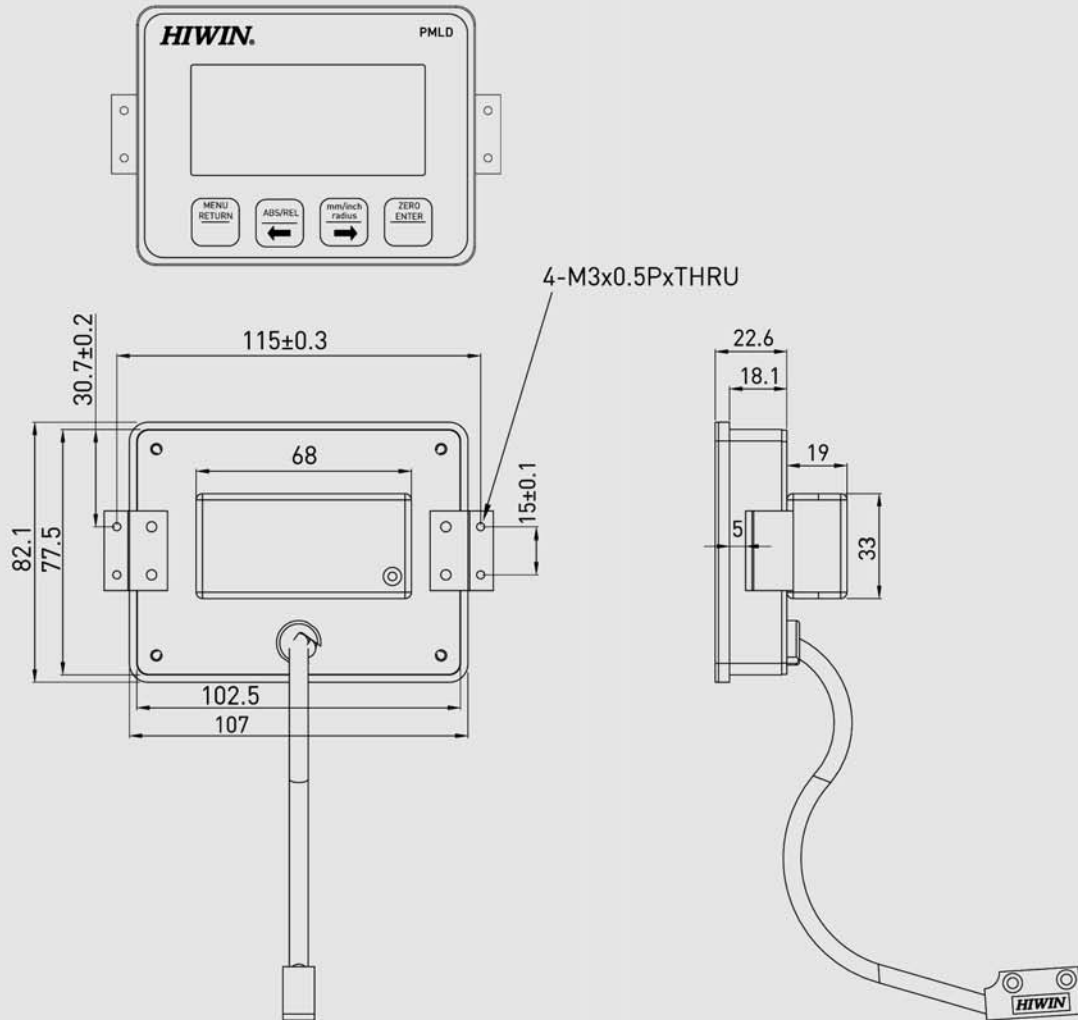

# Linear Guideways

## PG Type

### 2-6-3 Accuracy Classes

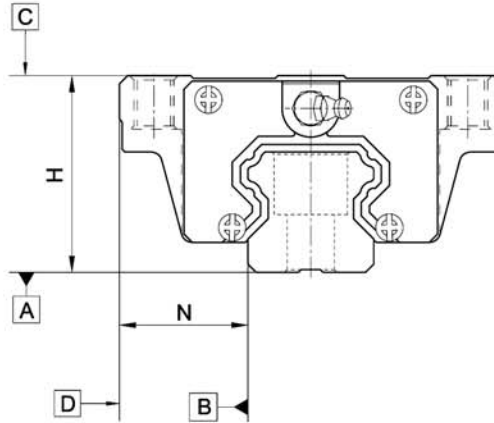
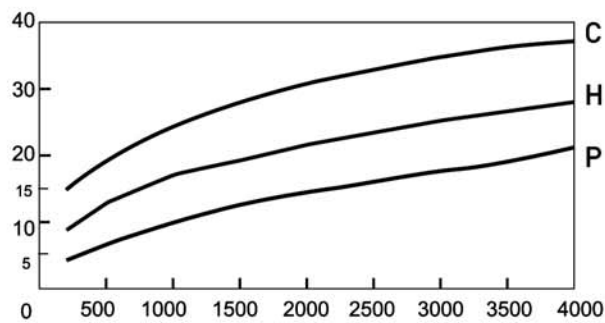

Table 2.76 For example: PGH 25, 30, 35

Unit: mm

Accuracy Classes	Normal (c)	High (H)	Precision (P)
Dimensional tolerance of height H	$\pm 0.1$	$\pm 0.04$	0 -0.04
Dimensional tolerance of width N	$\pm 0.1$	$\pm 0.04$	0 -0.04
Pair Variation of height H	0.02	0.015	0.007
Pair Variation of width N (Master Rail)	0.03	0.015	0.007
Running parallelism of block surface C to surface A	See chart below		
Running parallelism of block surface D to surface B	See chart below		

#### Running parallelism of the guideway



### 2-6-4 Preload

Table 2.77 PGH-series

Class	Code	Preload
Light Preload	Z0	0-0.02C
Medium Preload	ZA	0.05C-0.07C
Heavy Preload	ZB	0.10C-0.12C

Note: "C" in column preload means basic dynamic load rating.

## 2-6-5 Dimensions for PG Series

### (1) PGHH-CA / PGHH-HA

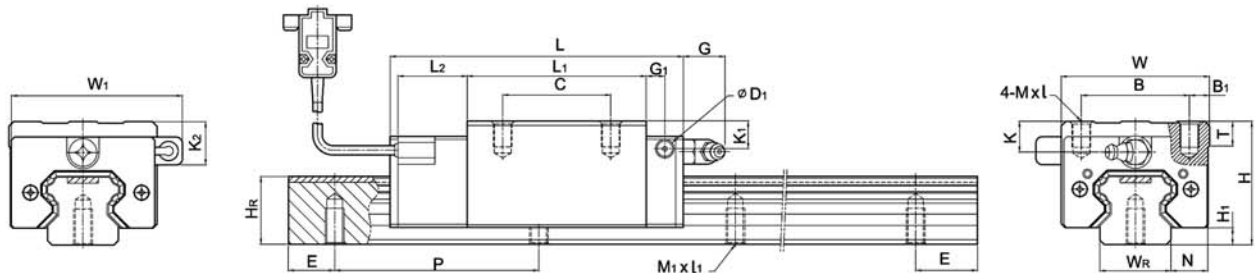

Model No.	Dimensions of Assembly (mm)		Dimensions of Block (mm)																	Dimensions of Rail (mm)					Basic Dynamic Load Rating	Basic Static Load Rating	Weight			
	H	H <sub>1</sub>	N	W	W <sub>1</sub>	B	B <sub>1</sub>	C	L	L <sub>1</sub>	L <sub>2</sub>	G	G <sub>1</sub>	D <sub>1</sub>	K	K <sub>1</sub>	K <sub>2</sub>	Mxl	T	W <sub>R</sub>	H <sub>R</sub>	M <sub>1</sub> x <sub>l<sub>1</sub></sub>	P	E			C (kN)	C <sub>0</sub> (kN)	Block	Rail
	kg	kg/m																												
PGHH20CA	30	4.6	12	44	52	32	6	36	90.5	50.5																17.75	37.84	0.38	2.21	
PGHH20HA								50	105	65.2	25	12	6	5	6	7	11	M5x6	8	20	17.5	M6x10	60	20	21.18	48.84	0.39			
PGHH25CA	40	5.5	12.5	48	55.4	35	6.5	35	95	58																26.48	56.19	0.51	3.21	
PGHH25HA								50	116	78.6	22.5	12	6	5	10	13	18	M6x8	8	23	22	M6x12	60	20	32.75	76.00	0.69			
PGHH30CA	45	6	16	60	67	40	10	40	110	70																38.74	83.06	0.88	4.47	
PGHH30HA								60	133	93	23	12	6	5	9.5	13.8	19	M8x10	8.5	28	26	M8x15	80	20	47.27	110.13	1.16			
PGHH35CA	55	7.5	18	70	77	50	10	50	123	80																	49.52	102.87	1.45	6.30
PGHH35HA								72	149	106	23.4	12	7	5	16	19.6	23.5	M8x12	10.2	34	29	M8x17	80	20	60.21	136.31	1.92			
PGHH45CA	70	9.5	20.5	86	91	60	13	60	148	97																	77.57	155.93	2.73	10.41
PGHH45HA								80	180	129	26	12.9	10	8.5	18.5	30.5	30.5	M10x17	16	45	38	M12x24	105	22.5	94.54	207.12	3.61			
PGHH55CA	80	13	23.5	100	106	75	12.5	75	173	118																	114.44	227.81	4.17	15.08
PGHH55HA								95	198	143	26	12.9	11	8.5	22	29	28.5	M12x18	17.5	53	44	M14x25	120	30	139.35	301.26	5.49			

Note : 1 kgf = 9.81 N

# Linear Guideways

## PG Type

### (2) PGHW-CA / PGHW-HA

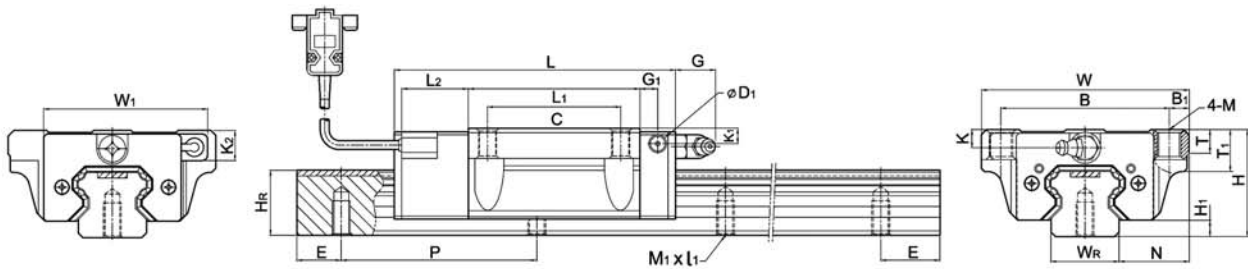

Model No.	Dimensions of Assembly (mm)		Dimensions of Block (mm)																	Dimensions of Rail (mm)				Basic Dynamic Load Rating	Basic Static Load Rating	Weight						
	H	H <sub>1</sub>	N	W	W <sub>1</sub>	B	B <sub>1</sub>	C	L	L <sub>1</sub>	L <sub>2</sub>	G	G <sub>1</sub>	D <sub>1</sub>	M	K	K <sub>1</sub>	K <sub>2</sub>	T	T <sub>1</sub>	W <sub>R</sub>	H <sub>R</sub>	M <sub>1</sub> xL <sub>1</sub>			P	E	C (kN)	C <sub>0</sub> (kN)	Block	Rail	
	kg	kg/m																														
PGHW20CA	30	4.6	21.5	63	52	53	5	40	90.5	50.5																	17.75	37.84	0.40	2.21		
PGHW20HA									105	65.2	25	12	6	5	M6	6	7	11	8	10	20	17.5		M6x10	60	20	21.18	48.84	0.52			
PGHW25CA	36	5.5	23.5	70	55.4	57	6.5	45	95	58																		26.48	56.19	0.59	3.21	
PGHW25HA									116	78.6	22.5	12	6	5	M8	6	9	14	8	14	23	22	M6x12	60	20	32.75	76.00	0.80				
PGHW30CA	42	6	31	90	67	72	9	52	110	70																			38.74	83.06	1.09	4.47
PGHW30HA									133	93	23	12	6	5	M10	6.5	10.8	16	8.5	16	28	26	M8x15	80	20	47.27	110.13	1.44				
PGHW35CA	48	7.5	33	100	77	82	9	62	123	80																			49.52	102.87	1.56	6.30
PGHW35HA									149	106	23.4	12	7	5	M10	9	12.6	16.5	10.1	18	34	29	M8x17	80	20	60.21	136.31	2.06				
PGHW45CA	60	9.5	37.5	120	91	100	10	80	148	97																			77.57	155.93	2.79	10.41
PGHW45HA									180	129	26	12.9	10	8.5	M12	8.5	20	20	15.1	22	45	38	M12x24	105	22.5	94.54	207.12	3.69				
PGHW55CA	70	13	43.5	140	106	116	12	95	173	118																			114.44	227.81	4.52	15.08
PGHW55HA									198	143	26	12.9	11	8.5	M14	12	19	18.5	17.5	26.5	53	44	M14x25	120	30	139.35	301.26	5.96				

Note : 1 kgf = 9.81 N



## 2-7 SE Type - Metallic End Cap Linear Guideway

### 2-7-1 General Information

#### (1) Features

- Use of Metallic parts; (if end seal is needed, the high-temperature rubber in end seal is available).
- Excellent temperature resistance; service temperature under 150 °C.

#### (2) Applications

- Heat treatment equipment,
- Applications using vacuums (no vapor dispersion from plastic or rubber)
- Welding equipment.

### 2-7-2 Structure

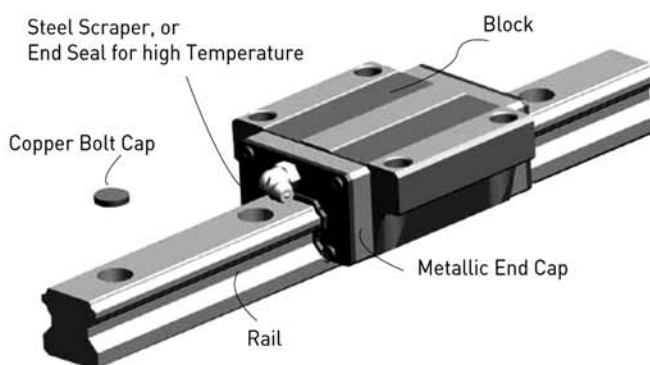

### 2-7-3 Specification

#### (1) Add "/ SE" after the specification of linear guideway

Ex. HGW25CA2R1000Z0PII + ZZ / SE

### 2-7-4 Dimensions of Copper Bolt Cap

Table 2.78

Item	Bolt Size	Cap Diameter (mm)	Cap Thickness (mm)
C3	M3	6.15	1.2
C4	M4	7.65	1.2
C5	M5	9.65	2.8
C6	M6	11.15	2.8
C8	M8	14.15	3.5
C12	M12	20.15	4
C12	M14	23.15	4

# Linear Guideways

## Q1 Type

### 2-8 Q1 Type – Quiet Linear Guideway, with SynchMotion™ Technology

The development of HIWIN-Q1 linear guideway is based on a four-row circular-arc contact. The HIWIN-Q1 series linear guideway with SynchMotion™ Technology possesses all the advantages of the HIWIN-HG series, and also offers smooth movement, superior lubrication, quieter operation and longer running life. Therefore the HIWIN-Q1 linear guideway has broad industrial applicability. In the high-tech industry where high speed, low noise, and reduced dust generation is required, the HIWIN-Q1 series is interchangeable with the HIWIN-HG series. Please refer to 2-8-3 for detailed specifications.

#### 2-8-1 Construction

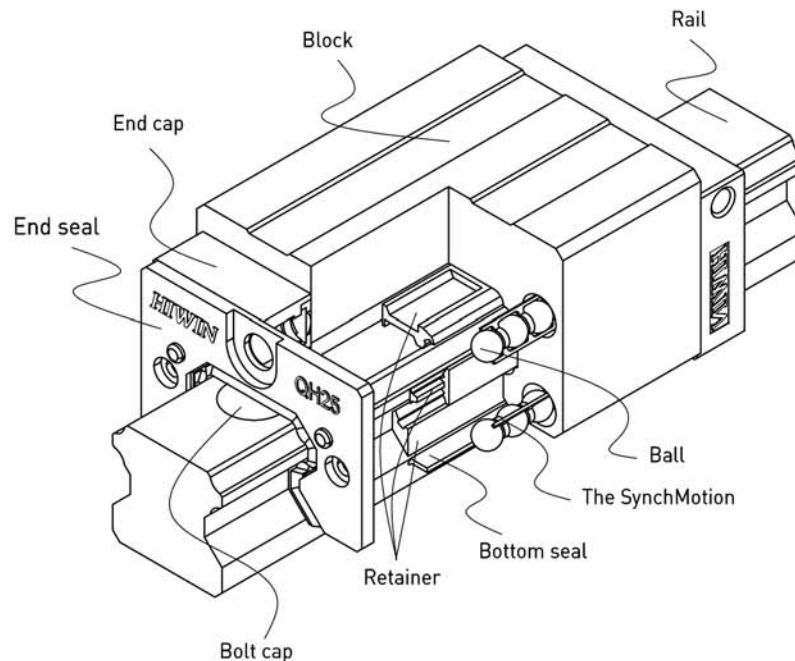

#### 2-8-2 Features

##### (1) Low Noise Design

With SynchMotion™ technology, rolling elements are interposed between the partitions of SynchMotion™ to provide improved circulation. Due to the elimination of contact between the rolling elements, collision noise and sound levels are drastically reduced.

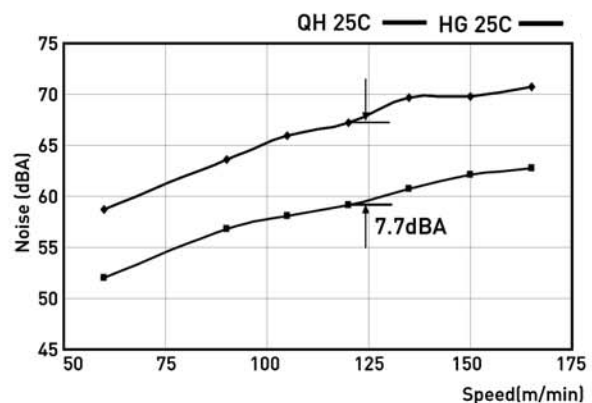
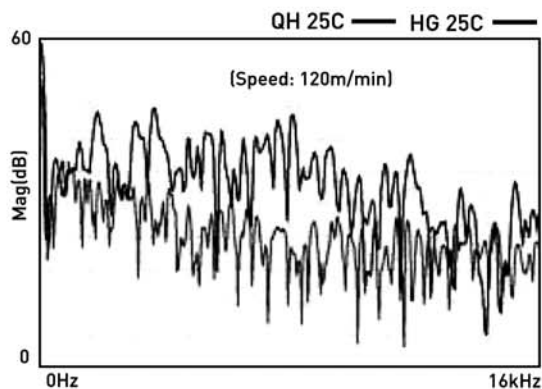

## (2) Self-Lubricant Design

The partition is a grouping of hollow ring-like structures formed with a through hole to facilitate circulation of the lubricant. Because of the special lubrication path design, the lubricant of the partition storage space can be refilled. Therefore, the frequency of lubricant refilling can be decreased.

The QH-series linear guideway is pre-lubricated. Performance testing at a 0.2C (basic dynamic load) shows that after running 2,500km no damage was apparent to either the rolling elements or the raceway.

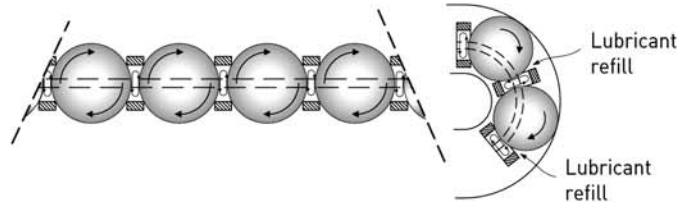
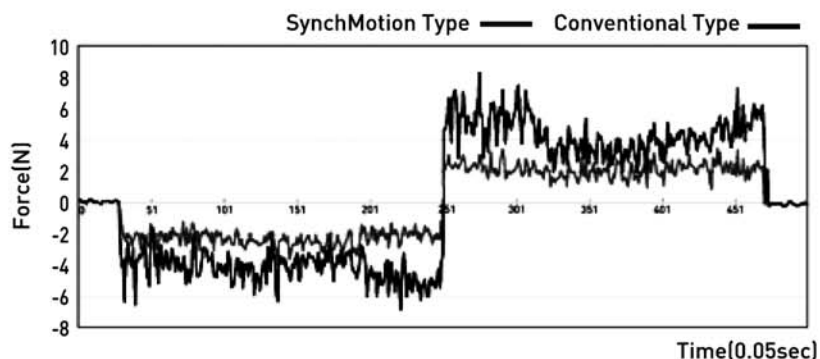

Table 2.79 Load Test

Test Sample	QHH25CAZAH	Load Test
Speed	24m/min	<p>Load=5,000N After 2,700km</p>
Lubricant	lithium soap base grease (initial lubrication only)	
Load	5kN	
Test times	6,800,000 cycles	
Distance travel	2,700km (continue testing)	

## (3) Smooth Movement

In standard linear guideways, rolling elements on the load side of the guide block begin rolling and push their way through the raceway. When they contact other rolling elements they create counter-rotational friction. This results in a great variation of rolling resistance. The QH linear guideway, with SynchMotion™ technology prevents this condition. As the block starts to move, the rolling elements begin rolling consecutively and remain separated to prevent contact with one another thus keeping the element's kinetic energy extremely stable in order to effectively reduce fluctuations in rolling resistance.



# Linear Guideways

## Q1 Type

### (4) High Speed Performance

The Hiwin-QH series offers excellent high-speed performance due to the partitions of the SynchMotion™ structure. They are employed to separate the adjacent balls thereby resulting in low rolling traction and the metallic friction between adjacent balls is eliminated.

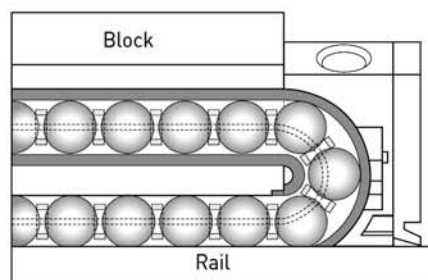

Table 2.80

Test Sample	QHW25CAZAH	High Speed Test
Speed	130m/min	<p>High Speed Test V=130m/min After 4,500km</p>
Lubricant	lithium soap base grease (initial lubrication only)	
Distance travel	4,500km (continue testing)	

### 2-8-3 Friction

The maximum value of seal resistance per block are shown in the table.

Table 2.81 Seal Resistance

Size	Resistance (kgf)
QH15	0.18
QH20	0.24
QH25	0.30
QH30	0.41
QH35	0.47

### 2-8-4 Model Number of QH Series

HIWIN-QH series guideway can be classified into non-interchangeable and interchangeable types. The sizes are identical. The main difference is that the interchangeable blocks and rails can be freely exchanged. Because of dimensional control, the interchangeable type linear guideway is a perfect choice for the client when rails do not need to be paired for an axis. And since the QH and HG share the identical rails, the customer does not need to redesign when choosing the QH series. Therefore the HIWIN-QH linear guideway has increased applicability.

**(1) Non-interchangeable type**

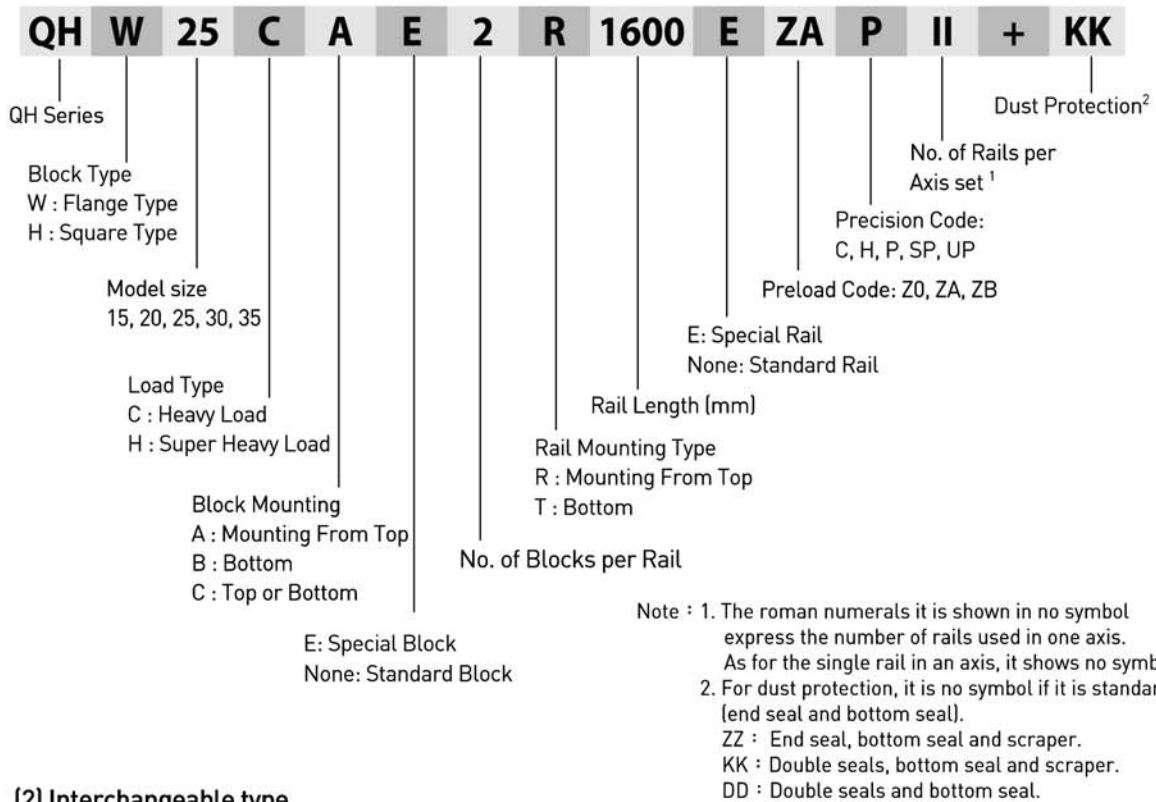

**(2) Interchangeable type**

○ **Model Number of QH Block**

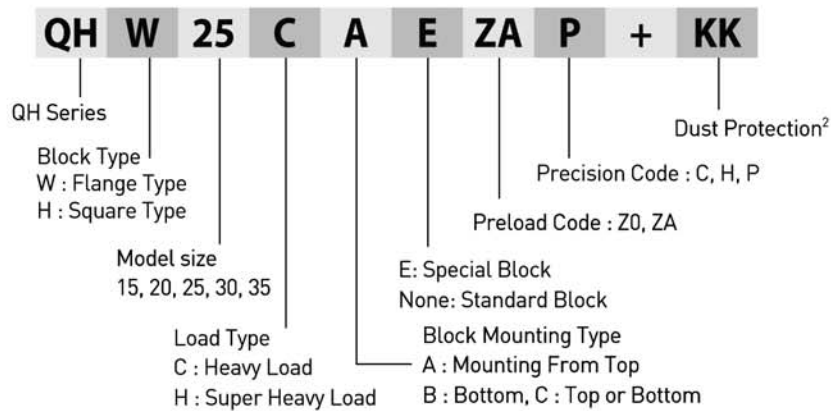

○ **Model Number of QH Rail**

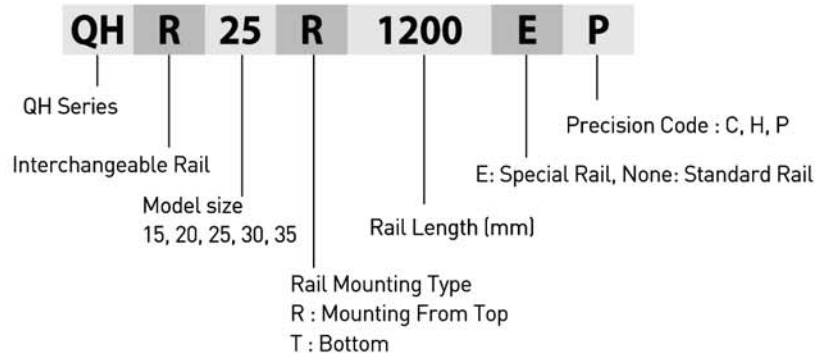

# Linear Guideways

## Q1 Type

### 2-8-5 Dimensions for HIWIN QH Series

#### (1) QHH-CA / QHH-HA

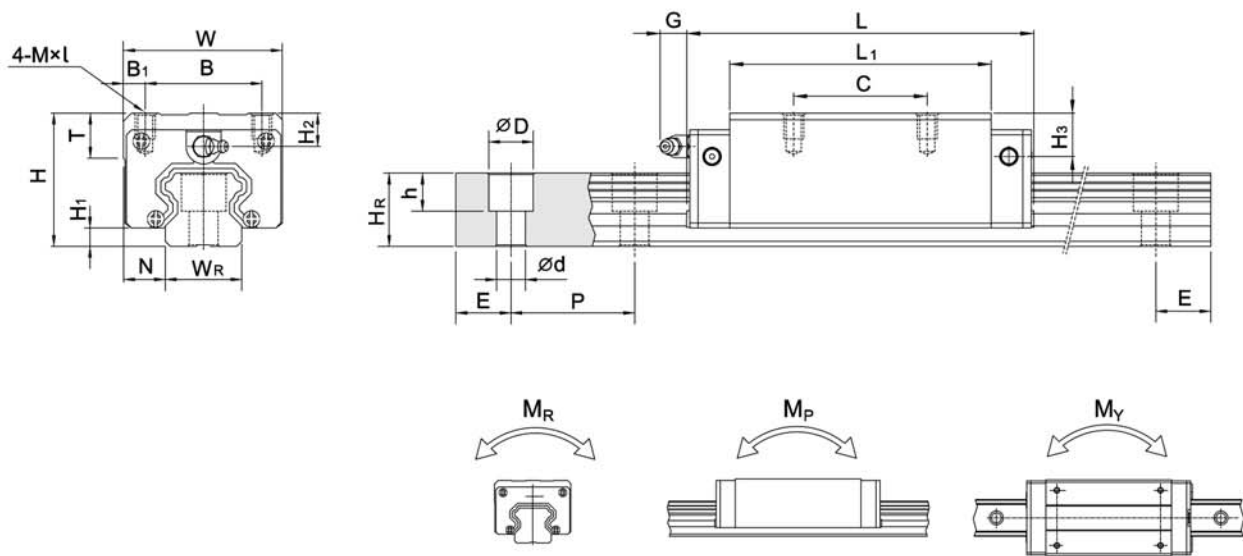

Model No.	Dimensions of Assembly (mm)			Dimensions of Block (mm)										Dimensions of Rail (mm)						Mounting Bolt for Rail (mm)	Basic Dynamic Load Rating C (kN)	Basic Static Load Rating C <sub>0</sub> (kN)	Static Rated Moment			Weight			
	H	H <sub>1</sub>	N	W	B	B <sub>1</sub>	C	L <sub>1</sub>	L	G	MxL	T	H <sub>2</sub>	H <sub>3</sub>	W <sub>R</sub>	H <sub>R</sub>	D	h	d				P	E	M <sub>R</sub>	M <sub>P</sub>	M <sub>Y</sub>	Block	Rail
	kgf	kgf	kgf	kgf	kgf	kgf	kgf	kgf	kgf	kgf	kgf	kgf	kgf	kgf	kgf	kgf	kgf	kgf	kgf				kgf	kgf	kgf	kgf	kgf	kgf	kgf
QHH15CA	28	4	9.5	34	26	4	26	39.4	61.4	5.3	M4 x 5	6	8.5	9.75	15	15	7.5	5.3	4.5	60	20	M4x16	10.18	21.42	0.14	0.12	0.12	0.18	1.45
QHH20CA	30	4.6	12	44	32	6	36	50.5	77.5	12	M5 x 6	8	6	7	20	17.5	9.5	8.5	6	60	20	M5x16	16.83	34.93	0.35	0.26	0.26	2.21	
QHH20HA							50	65.2	92.2														19.49	43.09	0.42	0.30	0.30		0.38
QHH25CA	40	5.5	12.5	48	35	6.5	35	58	85	12	M6 x 8	8	10	12.5	23	22	11	9	7	60	20	M6x20	25.10	51.87	0.59	0.48	0.48	3.21	
QHH25HA							50	78.6	105.6														30.13	67.06	0.77	0.58	0.58		0.68
QHH30CA	45	6	16	60	40	10	40	70	97.4	12	M8x10	8.5	9.5	9	28	26	14	12	9	80	20	M8x25	36.72	76.67	0.97	0.81	0.81	4.47	
QHH30HA							60	93	120.4														45.40	103.65	1.32	1.12	1.12		1.15
QHH35CA	55	7.5	18	70	50	10	50	80	112.4	12	M8x12	10.2	16	13.5	34	29	14	12	9	80	20	M8x25	46.95	94.96	1.60	1.13	1.13	6.30	
QHH35HA							72	105.8	138.2														57.83	128.29	2.15	1.56	1.56		1.90

Note : 1 kgf = 9.81 N

## (2) QHW-CA / QHW-HA

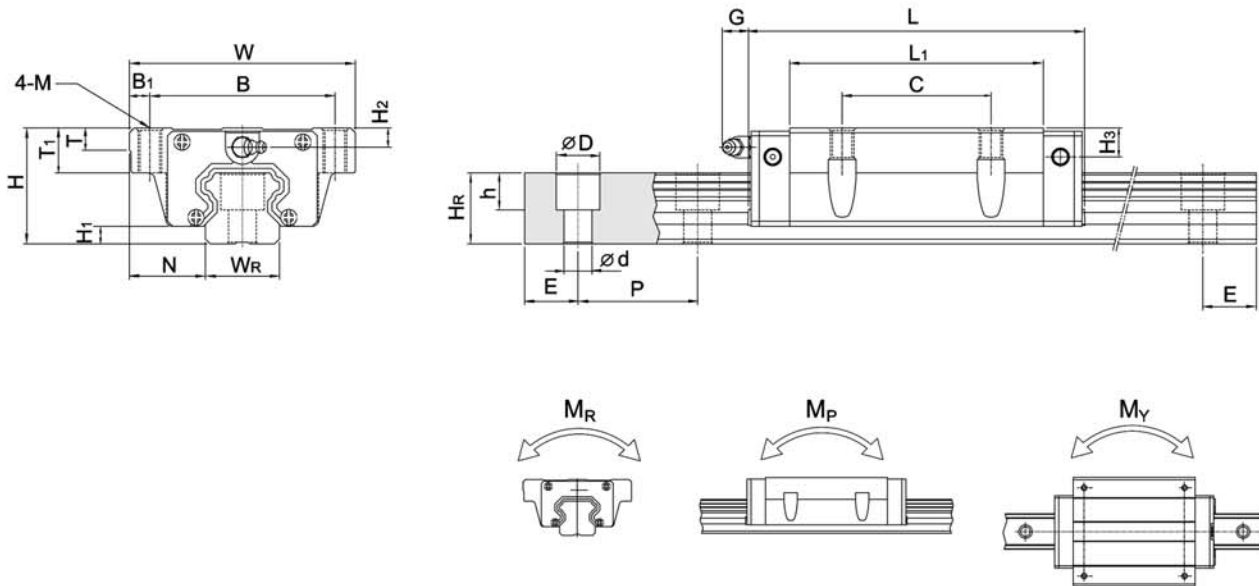

Model No.	Dimensions of Assembly (mm)		Dimensions of Block (mm)														Dimensions of Rail (mm)				Mounting Bolt for Rail (mm)	Basic Dynamic Load Rating C (kN)	Basic Static Load Rating C <sub>0</sub> (kN)	Static Rated Moment			Weight			
	H	H <sub>1</sub>	N	W	B	B <sub>1</sub>	C	L <sub>1</sub>	L	G	M	T	T <sub>1</sub>	H <sub>2</sub>	H <sub>3</sub>	W <sub>R</sub>	H <sub>R</sub>	D	h	d				P	E	M <sub>R</sub>	M <sub>P</sub>	M <sub>Y</sub>	Block	Rail
	kgf	mm	mm	mm	mm	mm	mm	mm	mm	mm	mm	mm	mm	mm	mm	mm	mm	mm	mm	mm				mm	mm	mm	kN-m	kN-m	kN-m	kg
QHW15CA	24	4	16	47	38	4.5	30	39.4	61.4	5.3	M5	6	8.9	4.5	5.8	15	15	7.5	5.3	4.5	60	20	M4x16	10.18	21.42	0.14	0.12	0.12	0.17	1.45
QHW20CA	30	4.6	21.5	63	53	5	40	50.5	77.5	12	M6	8	10	6	7	20	18	9.5	8.5	6	60	20	M5x16	16.83	34.93	0.38	0.26	0.26	0.40	2.21
QHW20HA								65.2	92.2															19.49	43.09	0.42	0.30	0.30	0.52	
QHW25CA	36	5.5	23.5	70	57	6.5	45	58	85	12	M8	8	14	6	8.5	23	22	11	9	7	60	20	M6x20	25.10	51.87	0.59	0.48	0.48	0.59	3.21
QHW25HA								78.6	105.6															30.13	67.06	0.77	0.58	0.58	0.80	
QHW30CA	42	6	31	90	72	9	52	70	97.4	12	M10	8.5	16	6.5	6	28	26	14	12	9	80	20	M8x25	36.72	76.67	0.97	0.81	0.81	1.09	4.47
QHW30HA								93	120.4															45.40	103.65	1.32	1.12	1.12	1.44	
QHW35CA	48	7.5	33	100	82	9	62	80	112.4	12	M10	10.1	18	9	6.5	34	29	14	12	9	80	20	M8x25	46.95	94.96	1.60	1.13	1.13	1.56	6.30
QHW35HA								105.8	138.2															57.83	128.29	2.15	1.56	1.56	2.06	

Note : 1 kgf = 9.81 N

# Linear Guideways

## Q1 Type

### (3) QHW-CB / QHW-HB

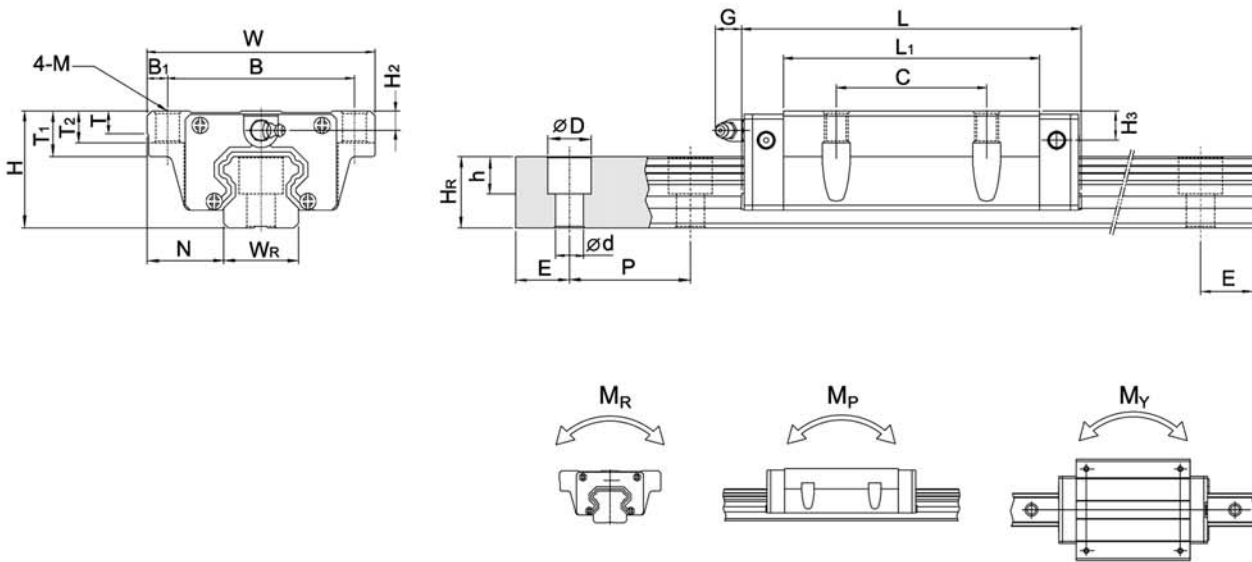

Model No.	Dimensions of Assembly (mm)		Dimensions of Block (mm)													Dimensions of Rail (mm)							Mounting Bolt for Rail (mm)	Basic Dynamic Load Rating C (kN)	Basic Static Load Rating C <sub>0</sub> (kN)	Static Rated Moment			Weight		
	H	H <sub>1</sub>	N	W	B	B <sub>1</sub>	C	L <sub>1</sub>	L	G	M	T	T <sub>1</sub>	T <sub>2</sub>	H <sub>2</sub>	H <sub>3</sub>	W <sub>R</sub>	H <sub>R</sub>	D	h	d	P				E	M <sub>R</sub> (kN-m)	M <sub>P</sub> (kN-m)	M <sub>Y</sub> (kN-m)	Block (kg)	Rail (kg/m)
QHW15CB	24	4	16	47	38	4.5	30	39.4	61.4	5.3	4.5	6	8.9	6.95	4.5	5.75	15	15	7.5	5.3	4.5	60	20	M4x16	10.18	21.42	0.14	0.12	0.12	0.17	1.45
QHW20CB	30	4.6	21.5	63	53	5	40	50.5	77.5	12	ø 6	8	10	9.5	6	7	20	17.5	9.5	8.5	6	60	20	M5x16	16.83	34.93	0.35	0.26	0.26	0.40	2.21
QHW20HB								65.2	92.2																19.49	43.09	0.42	0.30	0.30	0.52	
QHW25CB	36	5.5	23.5	70	57	6.5	45	58	85	12	ø 7	8	14	13	6	8.5	23	22	11	9	7	60	20	M6x20	25.10	51.87	0.59	0.48	0.48	0.59	3.21
QHW25HB								78.6	105.6																30.13	67.06	0.77	0.58	0.58	0.80	
QHW30CB	42	6	31	90	72	9	52	70	97.4	12	ø 9	8.5	16	15	6.5	6	28	26	14	12	9	80	20	M8x25	36.72	76.67	0.97	0.81	0.81	1.09	4.47
QHW30HB								93	120.4																45.40	103.65	1.32	1.12	1.12	1.44	
QHW35CB	48	7.5	33	100	82	9	62	80	112.4	12	ø 9	10.1	18	17	9	6.5	34	29	14	12	9	80	30	M8x25	46.95	94.96	1.60	1.13	1.13	1.56	6.30
QHW35HB								105.8	138.2																57.83	128.29	2.15	1.56	1.56	2.06	

Note : 1 kgf = 9.81 N



#### [4] QHW-CC / QHW-HC

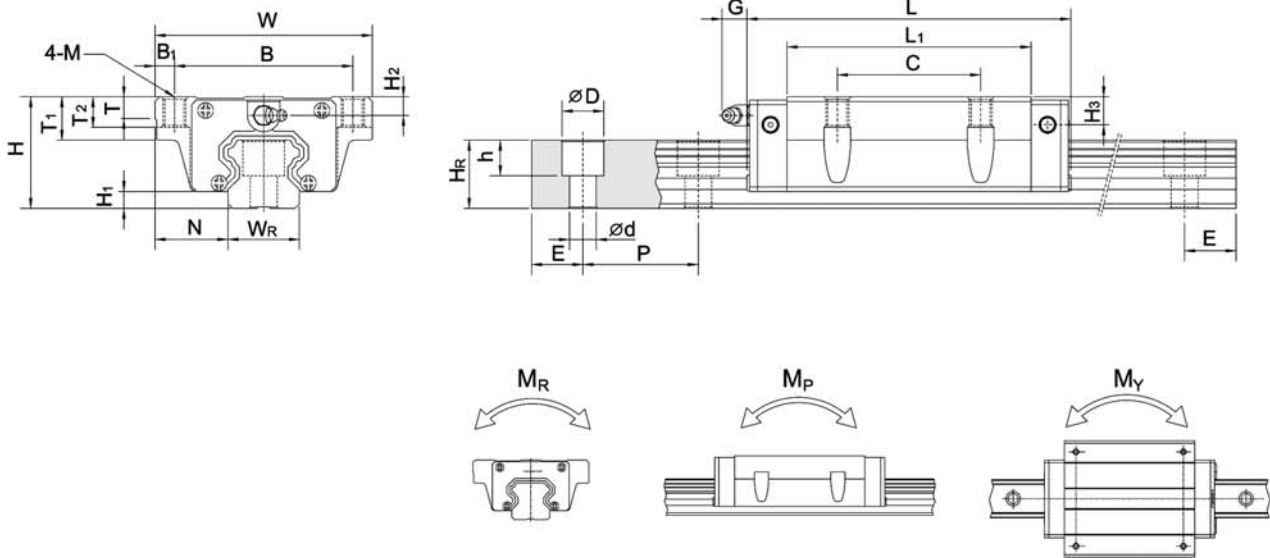

Model No.	Dimensions of Assembly (mm)		Dimensions of Block (mm)													Dimensions of Rail (mm)					Mounting Bolt for Rail (mm)	Basic Dynamic Load Rating C (kN)	Basic Static Load Rating C <sub>0</sub> (kN)	Static Rated Moment			Weight				
	H	H <sub>1</sub>	N	W	B	B <sub>1</sub>	C	L <sub>1</sub>	L	G	M	T	T <sub>1</sub>	T <sub>2</sub>	H <sub>2</sub>	H <sub>3</sub>	W <sub>R</sub>	H <sub>R</sub>	D	h				d	P	E	M <sub>R</sub>	M <sub>P</sub>	M <sub>Y</sub>	Block	Rail
	kg	mm	mm	mm	mm	mm	mm	mm	mm	mm	mm	mm	mm	mm	mm	mm	mm	mm	mm	mm				mm	mm	mm	mm	kN-m	kN-m	kN-m	kg
QHW15CC	24	4	16	47	38	4.5	30	39.4	61.4	5.3	M5	6	8.9	6.95	4.5	5.75	15	15	7.5	5.3	4.5	60	20	M4x16	10.18	21.42	0.14	0.12	0.12	0.17	1.45
QHW20CC	30	4.6	21.5	63	53	5	40	50.5	77.5	12	M6	8	10	9.5	6	7	20	17.5	9.5	8.5	6	60	20	M5x16	16.83	34.93	0.35	0.26	0.26	0.40	2.21
QHW20HC								65.2	92.2																19.49	43.09	0.42	0.30	0.30	0.52	
QHW25CC	36	5.5	23.5	70	57	6.5	45	58	85	12	M8	8	14	10	6	8.5	23	22	11	9	7	60	20	M6x20	25.10	51.87	0.59	0.48	0.48	0.59	3.21
QHW25HC								78.6	105.6																30.13	67.06	0.77	0.58	0.58	0.80	
QHW30CC	42	6	31	90	72	9	52	70	97.4	12	M10	8.5	16	10	6.5	6	28	26	14	12	9	80	20	M8x25	36.72	76.67	0.97	0.81	0.81	1.09	4.47
QHW30HC								93	120.4																45.40	103.65	1.32	1.12	1.12	1.44	
QHW35CC	48	7.5	33	100	82	9	62	80	112.4	12	M10	10.1	18	13	9	6.5	34	29	14	12	9	80	30	M8x25	46.95	94.96	1.60	1.13	1.13	1.56	6.30
QHW35HC								105.8	138.2																57.83	128.29	2.15	1.56	1.56	2.06	

Note : 1 kgf = 9.81 N

### 3. HIWIN Linear Guideway Inquiry Form

Customer:		Date:	
Tel.		Fax.	
Machine Type		Confirm by	
Axis		Drawing No.	
<input type="checkbox"/> X <input type="checkbox"/> Y <input type="checkbox"/> Z <input type="checkbox"/> Other (                    )			
Install Position	 <input type="checkbox"/> <input type="checkbox"/> <input type="checkbox"/> <input type="checkbox"/>		
	 <input type="checkbox"/> <input type="checkbox"/> <input type="checkbox"/> <input type="checkbox"/>		
Model No.			
Rail Mounting	<input type="checkbox"/> R (from top) <input type="checkbox"/> T (from bottom) <input type="checkbox"/> U (from top with bolt hole enlarged)		
Dust Protection	<input type="checkbox"/> Double end seal + Bottom seal (DD) <input type="checkbox"/> Double end seal + Scraper + Bottom seal (KK) <input type="checkbox"/> End seal + Scraper + Bottom seal (ZZ) <input type="checkbox"/> End seal + Bottom seal (U)		
Special Option	<input type="checkbox"/> Steel end cap (SE) <input type="checkbox"/> Self Lubrication (E2)		
Lubrication	<input type="checkbox"/> Grease nipple (Grease) <input type="checkbox"/> Piping joint (Oil) <input type="checkbox"/> Other		
Butt-joint	<input type="checkbox"/> No <input type="checkbox"/> Yes		
No. of Rail Per Axis	<input type="checkbox"/> I (1) <input type="checkbox"/> II (2) <input type="checkbox"/> III (3) <input type="checkbox"/> Other		
Reference Surface and Injection Direction	Please mark "X" in the <input type="checkbox"/> to indicate the filling directions.		
	 <input type="checkbox"/> E1 <input type="checkbox"/> E2 <input type="checkbox"/> E3 <input type="checkbox"/> E4		

**GUIDE LINEARI DI PRECISIONE**  
**PRECISION LINEAR GUIDEWAYS**

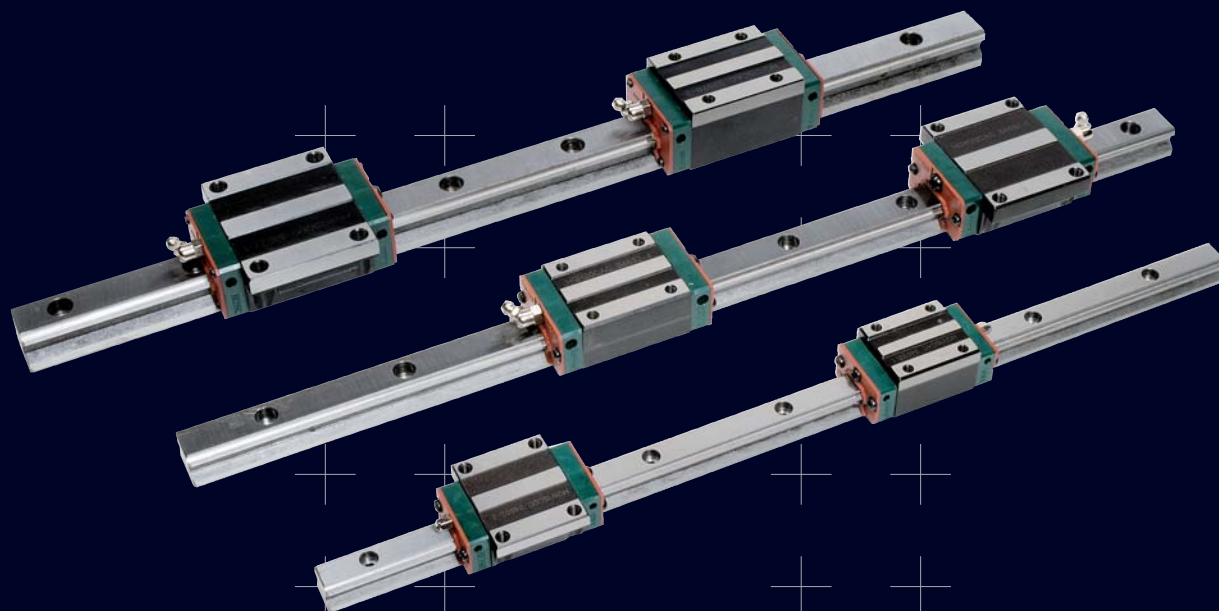

**JETEC**  
**COMPONENTI CONTROLLI SISTEMI DI MOTO**



## TORINO

*Direzione Generale - Headquarter:*

**Via Mappano, 17 - 10071 Borgaro T.se (TO)**  
**T +39 011 451 8611 (centr. r.a.) - F +39 011 470 4891**  
**setec.to@setec-group.it**



## MILANO

**Via Meccanica, 5**  
**20026 Novate (MI) - Z. I. Vialba**  
**T +39 02 356 0990 - 382 01 590 (r.a.)**  
**F +39 02 356 0943**  
**setec.mi@setec-group.it**



## BOLOGNA

**Via Del Lavoro, 6/A**  
**40051 Altedo (BO)**  
**T +39 051 871 949 (3 linee r.a.)**  
**F +39 051 870 329**  
**setec.bo@setec-group.it**

## PADOVA

**Via Secchi, 81**  
**35136 Padova**  
**T +39 049 872 5983**  
**F +39 049 856 0965**  
**setec.pd@setec-group.it**

## FIRENZE

**Via Galileo Galilei, 3**  
**50015 Bagno a Ripoli - Grassina (FI)**  
**T +39 055 643 261**  
**F +39 055 646 6614**  
**setec.fi@setec-group.it**

**www.setec-group.it**

