

# Linear Rail System

## SBG Standard Linear Rail System

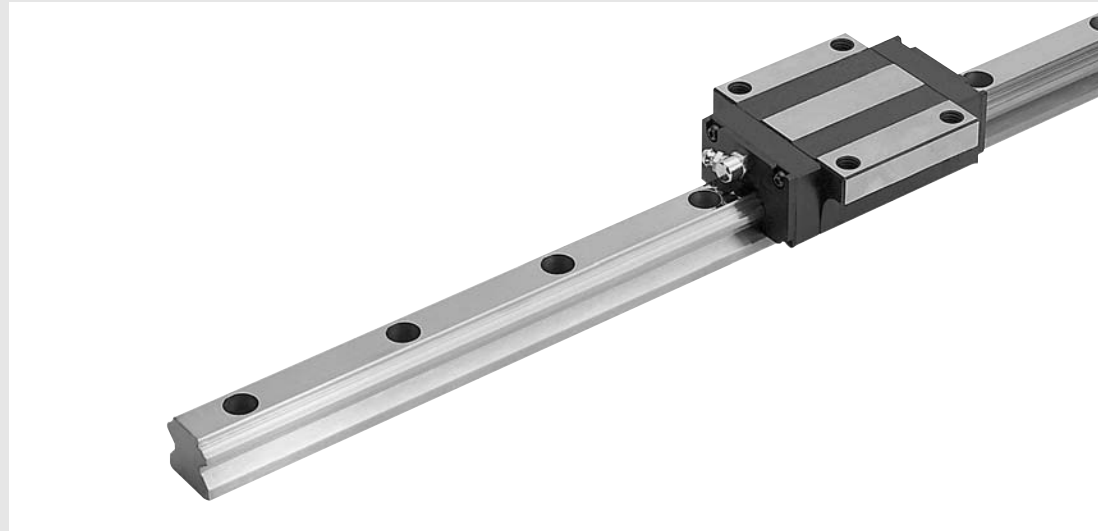

### Circular arc groove

Two pint contact structure of circular arc groove. It keeps the function of self-aligning and smooth rolling performance.

### 45° angle of contact

Four rows of circular arc groove contact balls at an angle of 45 degree. It provides the same load capacity in all directions.

### DF structure

### The same dimension

# Linear Rail System

## SBG Standard Linear Rail System

### The Block Structure

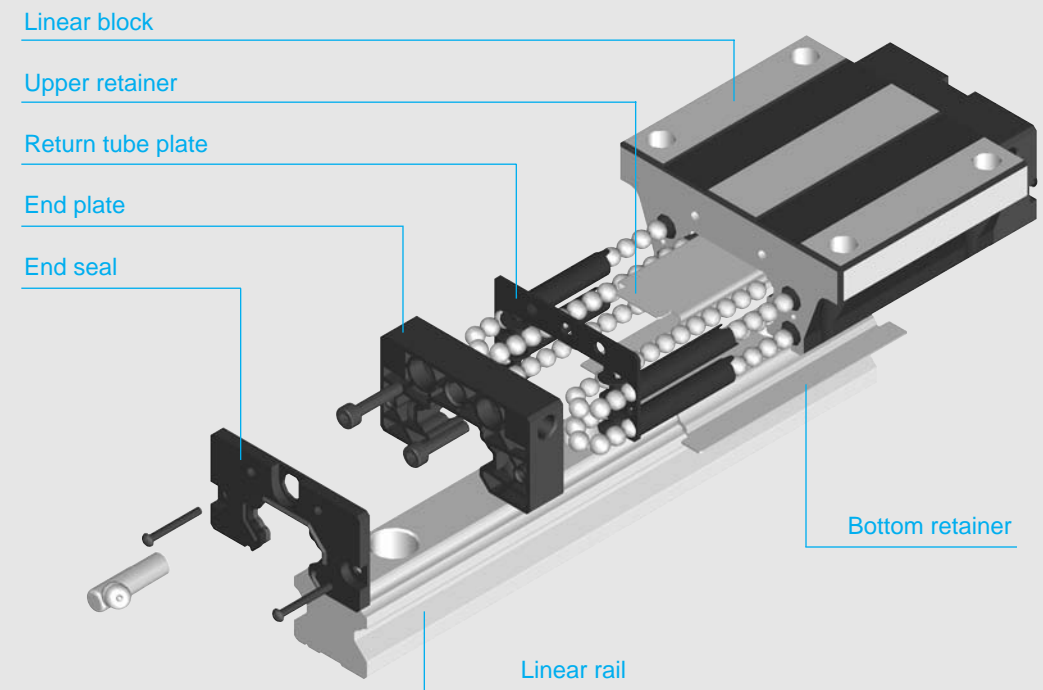

**Linear rail** The same rail profile may be used for every type of block (SBG, SBS, SPG and SPS). SBC uses only high strength and heat-treated special steels in all rails.

**Linear block** SBG, SBS, SPG and SPS types are available. All blocks are dimensionally interchangeable.

**End seal** New double lip structure which improves resistance to dust and particle contamination.

# Linear Rail System

## SBG Standard Linear Rail System

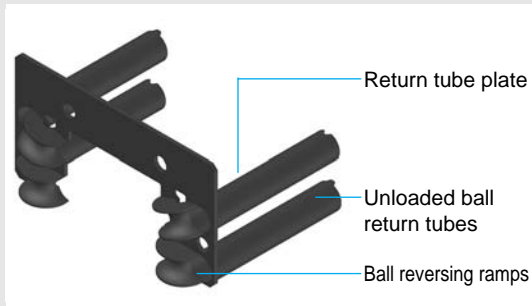

(Structure of return tube plate)

**Single component Return tube & reversing plate structure** Inserting a molded tube into the ball return paths keeps lubricant cleaner by providing better loose ball control and free lubricant flow while preventing metal to metal skidding contact with what is normally an imprecise return path wall.

※ Return tube plate is available for SBG(S), SPG(S) 20~35.

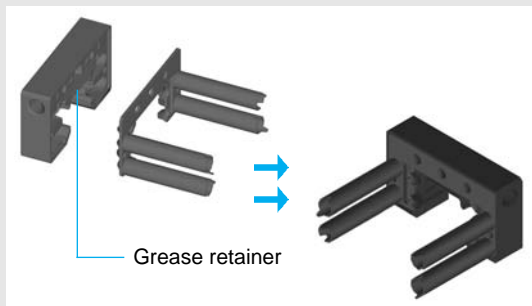

(Close fitting end-plate reduces grease loss)

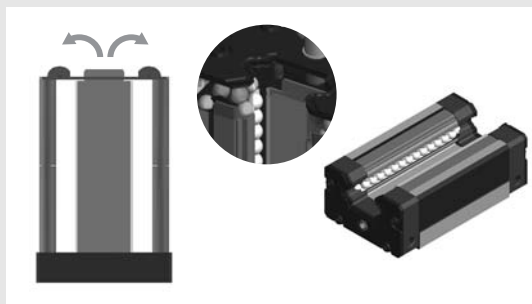

(Snap assembled)

**Retainer** Ball retainers are snap assembled to the internal body and end-plate without fixed position screws. The retainers can self align according to load orientation and direct the balls smoothly into the load zone. This function eliminates ball skid and hot zone pre-load creating smoother running and longer life. These new retainers are made of stainless steel (SUS304) and are corrosion resistant.

Bottom retainer is one body type with rubber seal to prevent contamination from bottom.

※ Bottom seal is not available for size 15 of SBG(S), SPG(S).

# Linear Rail System

## SBG Standard Linear Rail System

### SBG type

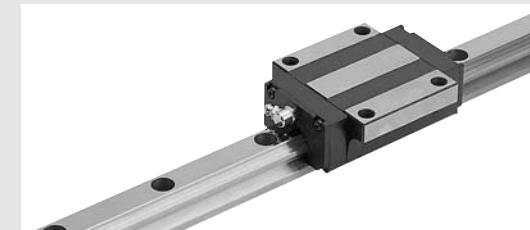

SBG is SBC standard linear block and FL, FLL, SL, SLL are available.

#### SBG-FL/FLL

-Flange type  
-Size 15~65

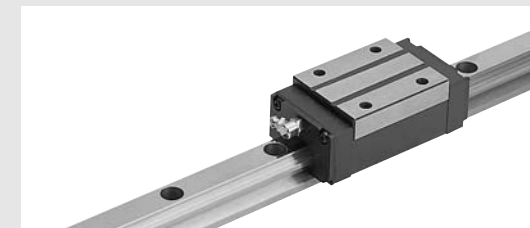

#### SBG-SL/SLL

-Slim type  
-Size 15~65

### SBS type



SBS type use same rail as SBG rail and the height is lower than SBG-SL type.

#### SBS-SL/SLL

-Slim type  
-Size 15~45

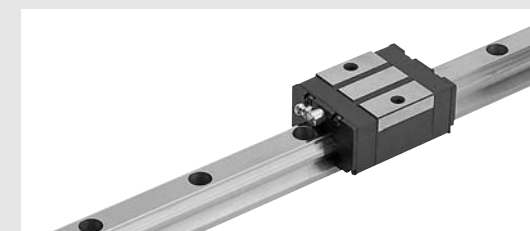

#### SBS-HL/HLL

-SBS-SL (Height is higher than SBS-SL/SLL type)  
-Size 25

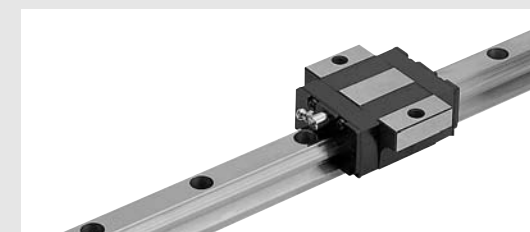

#### SBS-FV

-Flange type with shorter length  
-Size 15~25

#### SBS-SV

-Slim type with shorter length  
-Size 15~25

### SBG-FL/FLL

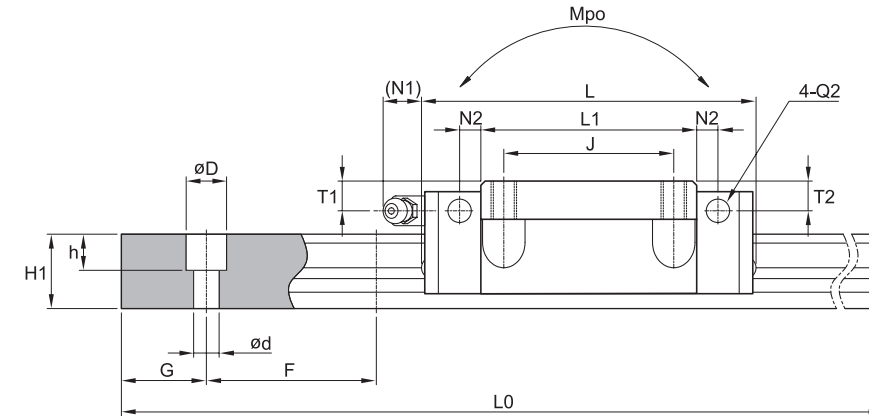
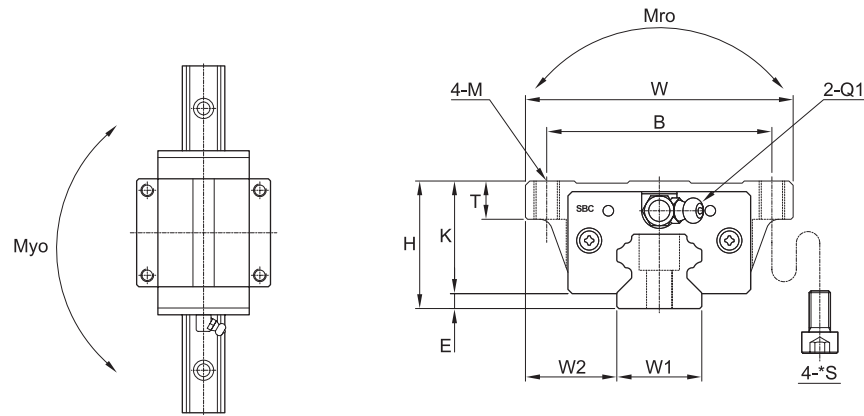

Model	Mounting dimension				Block dimensions												
	H	W	L	E	Mounting tap hole				L1	T	K	Grease fitting					
					B	J	M	*S				T1	N1	T2	N2	Q1	*Q2
SBG15 FL	24	47	60.8	3	38	30	M5	M4	38.8	7.2	21	4	5	5.5	4.5	M4x0.7	Ø4
SBG20 FL	30	63	77.2	3.5	53	40	M6	M5	50.8	9	26.5	7	9.8	11.7	5	M6x0.75	Ø6
SBG20 FLL	30	63	93.2	3.5	53	40	M6	M5	66.8	9	26.5	7	9.8	11.7	5	M6x0.75	Ø6
SBG25 FL	36	70	86.9	6.5	57	45	M8	M6	59.5	10	29.5	8.2	9.8	11.7	5.5	M6x0.75	Ø6
SBG25 FLL	36	70	106.4	6.5	57	45	M8	M6	79	10	29.5	8.2	9.8	11.7	5.5	M6x0.75	Ø6
SBG30 FL	42	90	100	7	72	52	M10	M8	70.4	12	35	8.5	10.7	11.7	5.5	M6x0.75	Ø6
SBG30 FLL	42	90	122.5	7	72	52	M10	M8	92.9	12	35	8.5	10.7	11.7	5.5	M6x0.75	Ø6
SBG35 FL	48	100	112.6	7.5	82	62	M10	M8	80.4	13	40.5	8	10.7	11.7	6	M6x0.75	Ø6
SBG35 FLL	48	100	138.1	7.5	82	62	M10	M8	105.9	13	40.5	8	10.7	11.7	6	M6x0.75	Ø6
SBG45 FL	60	120	140.4	10	100	80	M12	M10	98	15	50	10	11	16.5	8	PT1/8	Ø6
SBG45 FLL	60	120	172.4	10	100	80	M12	M10	130	15	50	10	11	16.5	8	PT1/8	Ø6
SBG55 FL	70	140	164.8	13	116	95	M14	M12	118	17	57	12	11	16.5	10	PT1/8	PT1/8
SBG55 FLL	70	140	202.8	13	116	95	M14	M12	156	17	57	12	11	16.5	10	PT1/8	PT1/8
SBG65 FL	90	170	195.2	17.5	142	110	M16	M14	147	23	72.5	15	11	16.5	10	PT1/8	PT1/8
SBG65 FLL	90	170	255.2	17.5	142	110	M16	M14	207	23	72.5	15	11	16.5	10	PT1/8	PT1/8

- ① C (Basic dynamic load rating), Co (Basic static load rating)
- ② \*S: Bolt size for bottom mounting type of block.

(Unit : mm)

Rail dimension										Basic load rating		Permissible static moment			Mass	
W1	W2	H1	F	Bolt hole			G	Max length of rail L0	C	Co	Mro	Mpo	Myo	Block [kg]	Rail [kg/m]	
				d	D	h										
15	16	15	60	4.5	7.5	5.3	20	3000	8.33	13.4	0.07	0.05	0.05	0.18	1.45	
20	21.5	17.5	60	6	9.5	8.5	20	4000	14.2	25	0.22	0.18	0.18	0.42	2.2	
20	21.5	17.5	60	6	9.5	8.5	20	4000	16.9	36.5	0.28	0.31	0.31	0.54	2.2	
23	23.5	21.8	60	7	11	9	20	4000	20.9	39.2	0.35	0.31	0.3	0.62	3.1	
23	23.5	21.8	60	7	11	9	20	4000	24.6	48	0.43	0.49	0.48	0.78	3.1	
28	31	25	80	9	14	12	20	4000	29.2	53.8	0.59	0.49	0.48	1.1	4.45	
28	31	25	80	9	14	12	20	4000	35.3	67.9	0.74	0.79	0.78	1.44	4.45	
34	33	29	80	9	14	12	20	4000	38.8	68.6	0.94	0.74	0.72	1.57	6.4	
34	33	29	80	9	14	12	20	4000	46	90.4	1.24	1.3	1.28	2.14	6.4	
45	37.5	38	105	14	20	17	22.5	4000	61.6	110.6	1.98	1.56	1.54	2.96	11.25	
45	37.5	38	105	14	20	17	22.5	4000	75.5	138.5	2.45	2.33	2.3	3.75	11.25	
53	43.5	45	120	16	23	20	30	4000	91.2	156.9	3.37	2.69	2.65	4.49	15.25	
53	43.5	45	120	16	23	20	30	4000	111.8	196.6	4.19	4.05	3.97	5.68	15.25	
63	53.5	58.5	150	18	26	22	35	4000	147.9	240.1	6.17	4.85	4.75	8.7	23.9	
63	53.5	58.5	150	18	26	22	35	4000	189.1	320.4	8.18	8.34	8.14	9.5	23.9	

- ③ \*Q2: The hole of side grease nipple is not made to prevent a foreign substance from going into inside. When you order the side grease nipple, we build it by ourselves.

### SBG-SL/SLL

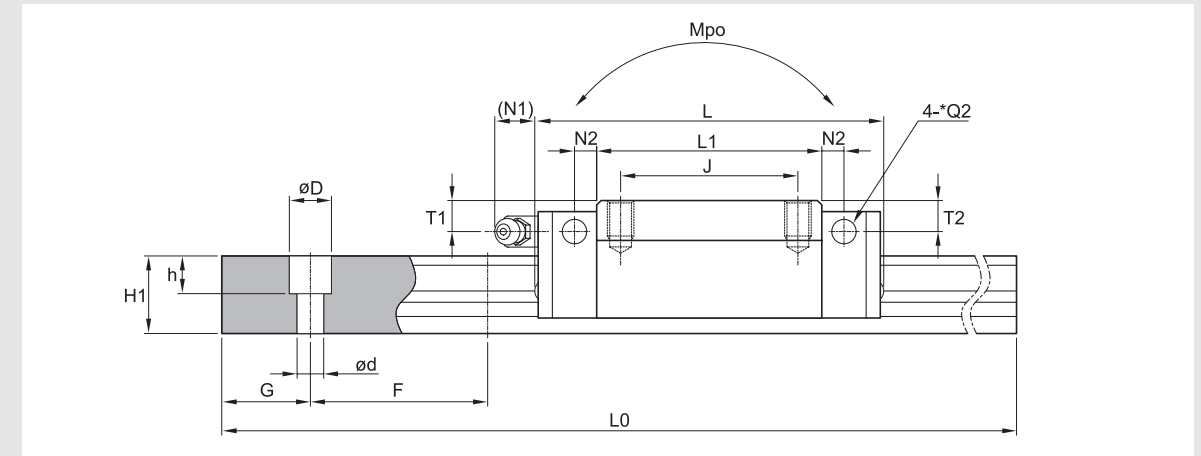
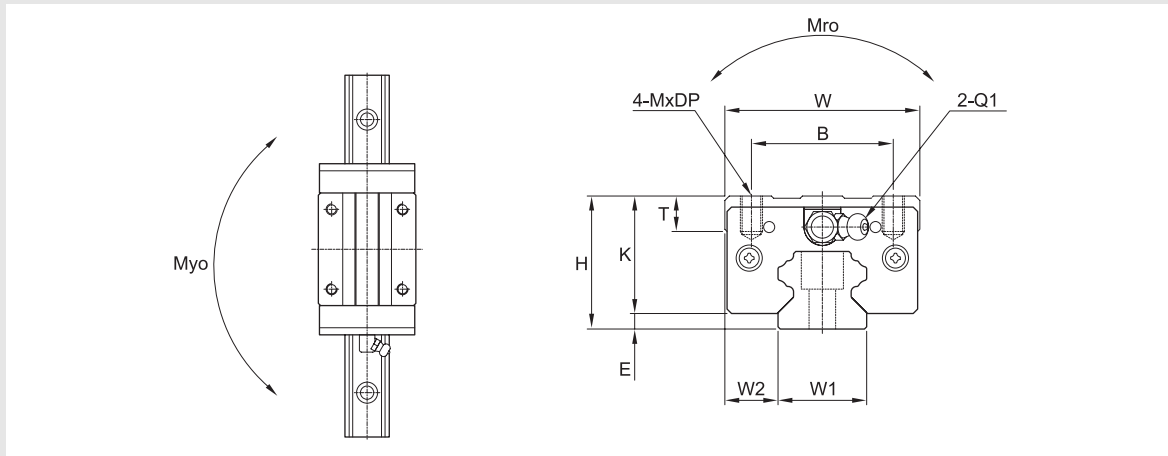

Model	Mounting dimension				Block dimensions													
	H	W	L	E	Mounting tap hole				L1	T	K	Grease fitting						
					B	J	M	DP				T1	N1	T2	N2	Q1	*Q2	
SBG15 SL	28	34	60.8	3	26	26	M4	5	38.8	8	25	8	5.5	8.5	4.5	M4x0.7	Ø4	
SBG20 SL	30	44	77.2	3.5	32	36	M5	8	50.8	8	26.5	7	11.7	7	5	M6x0.75	Ø6	
SBG20 SLL	30	44	93.2	3.5	32	50	M5	8	66.8	8	26.5	7	11.7	7	5	M6x0.75	Ø6	
SBG25 SL	40	48	86.9	6.5	35	35	M6	8	59.5	12	33.5	12.2	11.7	12.1	5.5	M6x0.75	Ø6	
SBG25 SLL	40	48	106.4	6.5	35	50	M6	8	79	12	33.5	12.2	11.7	12.1	5.5	M6x0.75	Ø6	
SBG30 SL	45	60	100	7	40	40	M8	10	70.4	12	38	11.5	11.7	11.5	5.5	M6x0.75	Ø6	
SBG30 SLL	45	60	122.5	7	40	60	M8	10	92.9	12	38	11.5	11.7	11.5	5.5	M6x0.75	Ø6	
SBG35 SL	55	70	112.6	7.5	50	50	M8	12	80.4	15	47.5	15	11.7	15	6	M6x0.75	Ø6	
SBG35 SLL	55	70	138.1	7.5	50	72	M8	12	105.9	15	47.5	15	11.7	15	6	M6x0.75	Ø6	
SBG45 SL	70	86	140.4	10	60	60	M10	13	98	15	60	15	16.5	20	8	PT1/8	Ø6	
SBG45 SLL	70	86	172.4	10	60	80	M10	13	130	15	60	15	16.5	20	8	PT1/8	Ø6	
SBG55 SL	80	100	164.8	13	75	75	M12	18	118	18	67	18	16.5	20.5	10	PT1/8	PT1/8	
SBG55 SLL	80	100	202.8	13	75	95	M12	18	156	18	67	18	16.5	20.5	10	PT1/8	PT1/8	
SBG65 SL	90	126	195.2	17.5	76	70	M16	20	147	23	72.5	23	16.5	12	10	PT1/8	PT1/8	
SBG65 SLL	90	126	255.2	17.5	76	120	M16	20	207	23	72.5	23	16.5	12	10	PT1/8	PT1/8	

① C (Basic dynamic load rating), Co (Basic static load rating)

(Unit : mm)

Rail dimension										Basic load rating		Permissible static moment			Mass	
W1	W2	H1	F	Bolt hole			G	Max length of rail L0	C	Co	Mro	Mpo	Myo	Block [kg]	Rail [kg/m]	
				d	D	h										
15	9.5	15	60	4.5	7.5	5.3	20	3000	8.33	13.4	0.07	0.05	0.05	0.2	1.45	
20	12	17.5	60	6	9.5	8.5	20	4000	14.2	25	0.22	0.18	0.18	0.33	2.2	
20	12	17.5	60	6	9.5	8.5	20	4000	16.9	36.5	0.28	0.31	0.31	0.45	2.2	
23	12.5	21.8	60	7	11	9	20	4000	20.9	39.2	0.35	0.31	0.3	0.56	3.1	
23	12.5	21.8	60	7	11	9	20	4000	24.6	48	0.43	0.49	0.48	0.73	3.1	
28	16	25	80	9	14	12	20	4000	29.2	53.8	0.59	0.49	0.48	0.98	4.45	
28	16	25	80	9	14	12	20	4000	35.3	67.9	0.74	0.79	0.78	1.28	4.45	
34	18	29	80	9	14	12	20	4000	38.8	68.6	0.94	0.74	0.72	1.63	6.4	
34	18	29	80	9	14	12	20	4000	46	90.4	1.24	1.3	1.28	2.12	6.4	
45	20.5	38	105	14	20	17	22.5	4000	61.6	110.6	1.98	1.56	1.54	2.96	11.25	
45	20.5	38	105	14	20	17	22.5	4000	75.5	138.5	2.45	2.33	2.3	3.75	11.25	
53	23.5	45	120	16	23	20	30	4000	91.2	156.9	3.37	2.69	2.65	4.52	15.25	
53	23.5	45	120	16	23	20	30	4000	111.8	196.6	4.19	4.05	3.97	5.68	15.25	
63	31.5	58.5	150	18	26	22	35	4000	147.9	240.1	6.17	4.85	4.75	7.43	23.9	
63	31.5	58.5	150	18	26	22	35	4000	189.1	320.4	8.18	8.34	8.14	12.05	23.9	

② \*Q2: The hole of side grease nipple is not made to prevent a foreign substance from going into inside. When you order the side grease nipple, we build it by ourselves.

### SBS-SL, HL/SLL, HLL

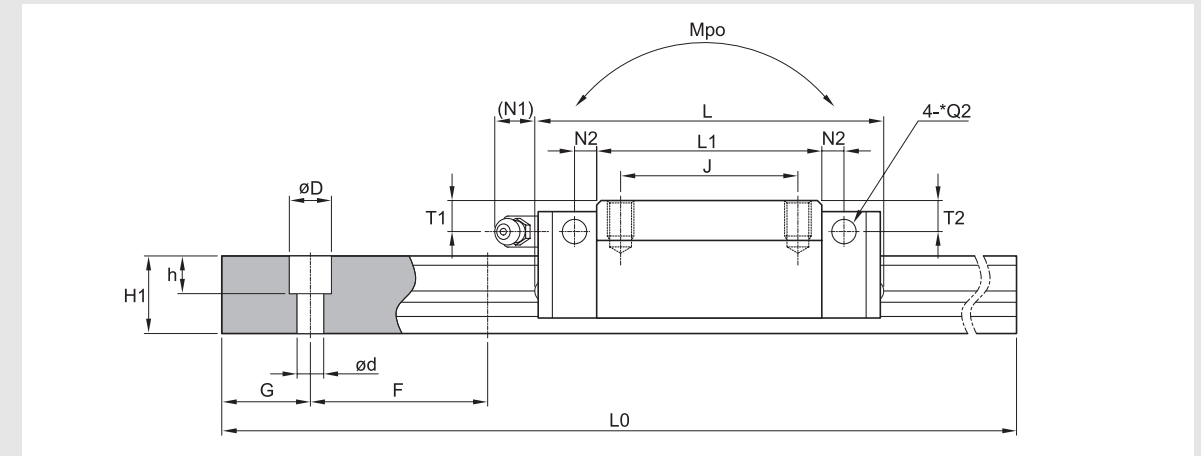
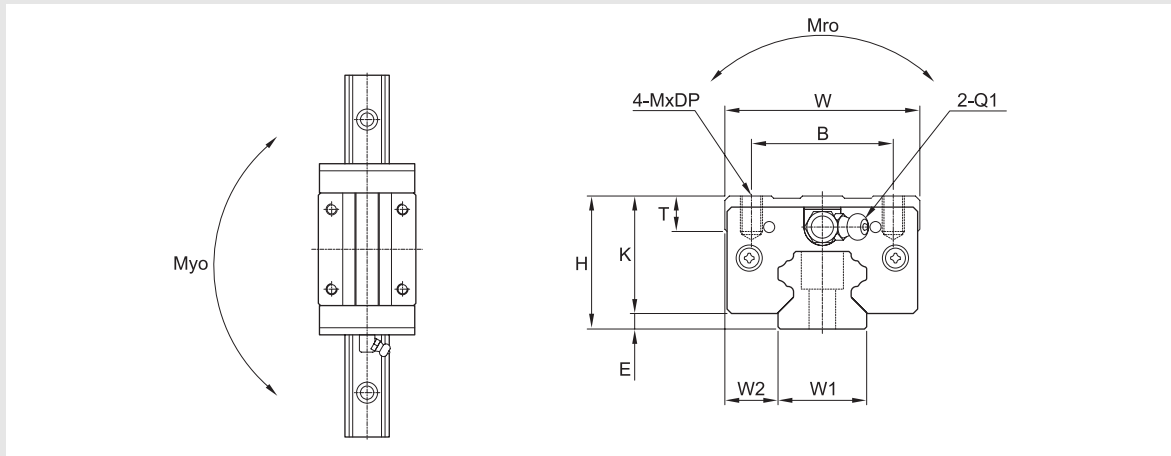

Model	Mounting dimension				Block dimensions													
	H	W	L	E	Mounting tap hole				L1	T	K	Grease fitting						
					B	J	M	DP				T1	N1	T2	N2	Q1	*Q2	
SBS15 SL	24	34	60.8	3	26	26	M4	5	38.8	6	21	4	5.5	4.5	4.5	M4x0.7	Ø4	
SBS20 SL	28	44	77.2	3.5	32	32	M5	7	50.8	7.5	24.5	5	11.7	5	5	M6x0.75	Ø6	
SBS20 SLL	28	44	93.2	3.5	32	50	M5	7	66.8	7.5	24.5	5	11.7	5	5	M6x0.75	Ø6	
SBS25 SL	33	48	86.9	6.5	35	35	M6	6	59.5	8	26.5	5.2	11.7	5.1	5.5	M6x0.75	Ø6	
SBS25 SLL	33	48	106.4	6.5	35	50	M6	6	79	8	26.5	5.2	11.7	5.1	5.5	M6x0.75	Ø6	
SBS25 HL	36	48	86.9	6.5	35	35	M6	8	59.5	11	29.5	8.2	11.7	8.1	5.5	M6x0.75	Ø6	
SBS25 HLL	36	48	106.4	6.5	35	50	M6	8	79	11	29.5	8.2	11.7	8.1	5.5	M6x0.75	Ø6	
SBS30 SL	42	60	100	7	40	40	M8	10	70.4	12	35	8.5	11.7	8.5	5.5	M6x0.75	Ø6	
SBS30 SLL	42	60	122.5	7	40	60	M8	10	92.9	12	35	8.5	11.7	8.5	5.5	M6x0.75	Ø6	
SBS35 SL	48	70	112.6	7.5	50	50	M8	12	80.4	15	40.5	8	11.7	8	6	M6x0.75	Ø6	
SBS35 SLL	48	70	138.1	7.5	50	72	M8	12	105.9	15	40.5	8	11.7	8	6	M6x0.75	Ø6	
SBS45 SL	60	86	140.4	10	60	60	M10	10	98	15	50	10	16.5	10	8	PT1/8	PT1/8	
SBS45 SLL	60	86	172.4	10	60	80	M10	10	130	15	50	10	16.5	10	8	PT1/8	PT1/8	

(Unit : mm)

Rail dimension										Basic load rating		Permissible static moment			Mass	
W1	W2	H1	F	Bolt hole			G	Max length of rail L0	C	Co	Mro	Mpo	Myo	Block [kg]	Rail [kg/m]	
				d	D	h										
15	9.5	15	60	4.5	7.5	5.3	20	3000	8.33	13.4	0.07	0.05	0.05	0.2	1.45	
20	12	17.5	60	6	9.5	8.5	20	4000	14.2	25	0.22	0.18	0.18	0.33	2.2	
20	12	17.5	60	6	9.5	8.5	20	4000	16.9	36.5	0.28	0.31	0.31	0.45	2.2	
23	12.5	21.8	60	7	11	9	20	4000	20.9	39.2	0.35	0.31	0.3	0.56	3.1	
23	12.5	21.8	60	7	11	9	20	4000	24.6	48	0.43	0.49	0.48	0.73	3.1	
23	12.5	21.8	60	7	11	9	20	4000	20.9	39.2	0.35	0.31	0.3	0.98	3.1	
23	12.5	21.8	60	7	11	9	20	4000	24.6	48	0.43	0.49	0.48	1.28	3.1	
28	16	25	80	9	14	12	20	4000	29.2	53.8	0.59	0.49	0.48	0.98	4.45	
28	16	25	80	9	14	12	20	4000	35.3	67.9	0.74	0.79	0.78	1.28	4.45	
34	18	29	80	9	14	12	20	4000	38.8	68.6	0.94	0.74	0.72	1.63	6.4	
34	18	29	80	9	14	12	20	4000	46	90.4	1.24	1.3	1.28	2.12	6.4	
45	20.5	38	105	14	20	17	22.5	4000	61.6	110.6	1.98	1.56	1.54	2.96	11.25	
45	20.5	38	105	14	20	17	22.5	4000	75.5	138.5	2.45	2.33	2.3	3.75	11.25	

① C (Basic dynamic load rating), Co (Basic static load rating)

② \*Q2: The hole of side grease nipple is not made to prevent a foreign substance from going into inside.  
When you order the side grease nipple, we build it by ourselves.

### SBS-FV

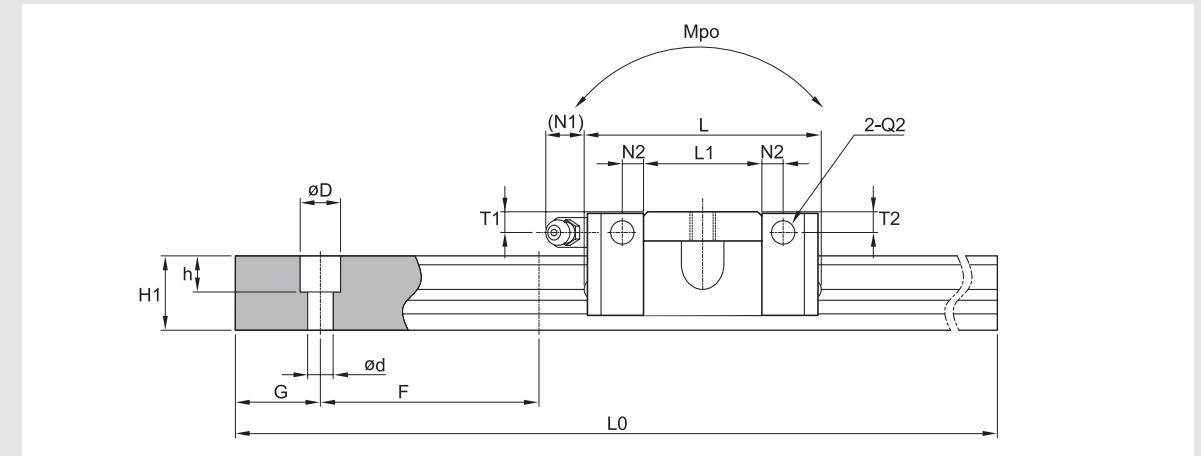
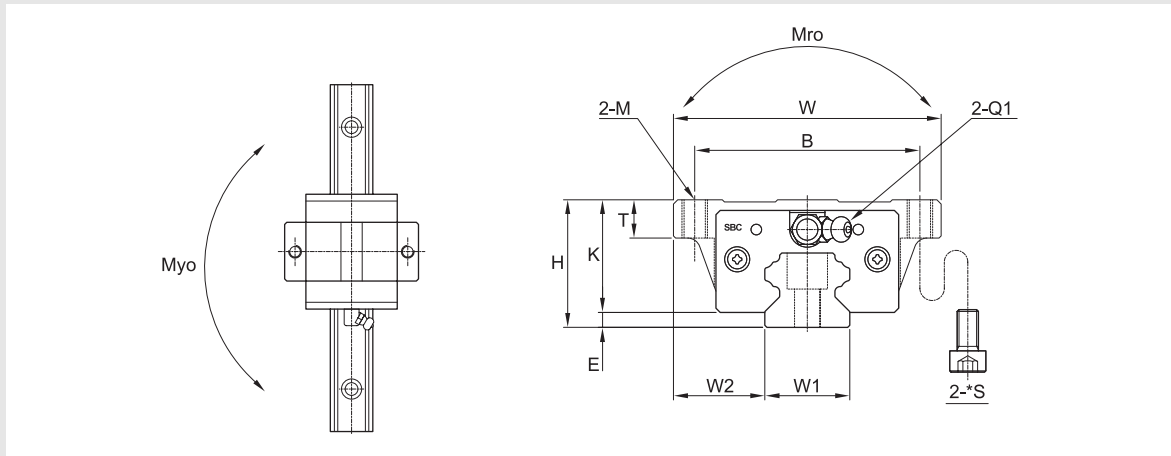

(Unit : mm)

Model	Mounting dimension				Block dimensions											
	H	W	L	E	Mounting tap hole			L1	T	K	Grease fitting					
					B	M	*S				T1	N1	T2	N2	Q1	*Q2
SBS15 FV	24	47	44.9	3	38	M5	M4	22.9	7.2	21	4	5.5	4.5	4.5	M4x0.7	Ø4
SBS20 FV	28	63	54.2	3.5	53	M6	M5	27.8	7	24.5	5	11.7	5	5	M6x0.75	Ø6
SBS25 FV	33	70	62.6	6.5	57	M8	M6	35.2	7	26.5	5.2	11.7	5.1	5.5	M6x0.75	Ø6

Rail dimension										Basic load rating		Permissible static moment			Mass	
W1	W2	H1	F	Bolt hole			G	Max length of rail L0	C	Co	Mro	Mpo	Myo	Block [kg]	Rail [kg/m]	
				d	D	h										
15	16	15	60	4.5	7.5	5.3	20	3000	4.48	7.23	0.04	0.03	0.03	0.1	1.45	
20	21.5	17.5	60	6	9.5	8.5	20	4000	7.65	13.5	0.12	0.1	0.1	0.24	2.2	
23	23.5	21.8	60	7	11	9	20	4000	11.29	21.1	0.19	0.17	0.17	0.37	3.1	

- ① C (Basic dynamic load rating), Co (Basic static load rating)
- ② \*S: Bolt size for bottom mounting type of block.
- ③ \*Q2: The hole of side grease nipple is not made to prevent a foreign substance from going into inside.  
When you order the side grease nipple, we build it by ourselves.



SBG Standard Linear Rail System

SBG Standard Linear Rail System

SBS-SV

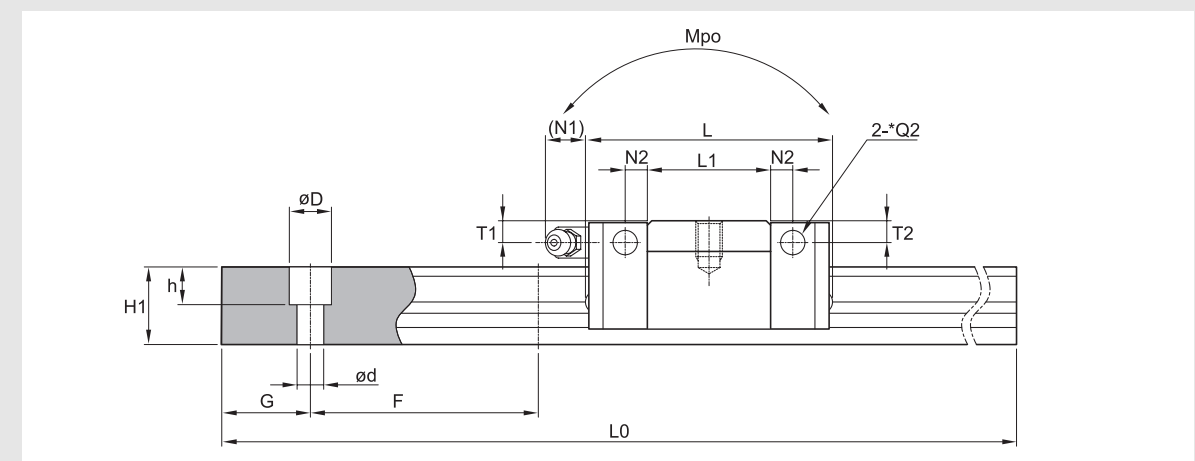
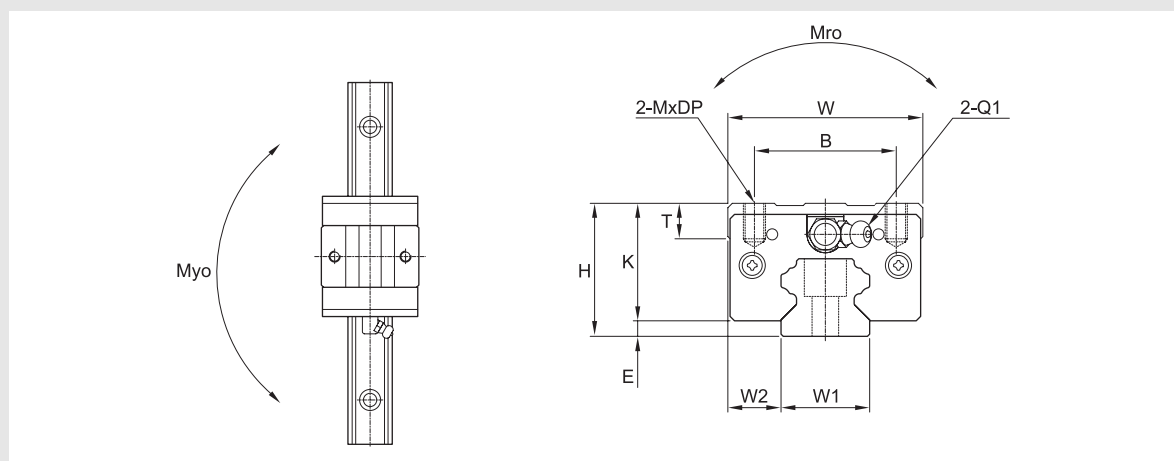

(Unit : mm)

Model	Mounting dimension				Block dimensions											
	H	W	L	E	Mounting tap hole			L1	T	K	Grease fitting					
					B	M	DP				T1	N1	T2	N2	Q1	*Q2
SBS15 SV	24	34	44.9	3	26	M4	5	22.9	6	21	4	5.5	4.5	4.5	M4x0.7	Ø4
SBS20 SV	28	44	54.2	3.5	32	M5	7	27.8	7.5	24.5	5	11.7	5	5	M6x0.75	Ø6
SBS25 SV	33	48	62.6	6.5	35	M6	6	35.2	8	26.5	5.2	11.7	5.1	5.5	M6x0.75	Ø6

Rail dimension									Basic load rating		Permissible static moment			Mass	
W1	W2	H1	F	Bolt hole			G	Max length of rail L0	C	Co	Mro	Mpo	Myo	Block [kg]	Rail [kg/m]
				d	D	h									
15	9.5	15	60	4.5	7.5	5.3	20	3000	4.48	7.23	0.04	0.03	0.03	0.1	1.45
20	12	17.5	60	6	9.5	8.5	20	4000	7.65	13.5	0.12	0.1	0.1	0.19	2.2
23	12.5	21.8	60	7	11	9	20	4000	11.29	21.1	0.19	0.17	0.17	0.32	3.1

① C (Basic dynamic load rating), Co (Basic static load rating)

② \*Q2: The hole of side grease nipple is not made to prevent a foreign substance from going into inside. When you order the side grease nipple, we build it by ourselves.



SBG Standard Linear Rail System

SBG Standard Linear Rail System

SBS-SV

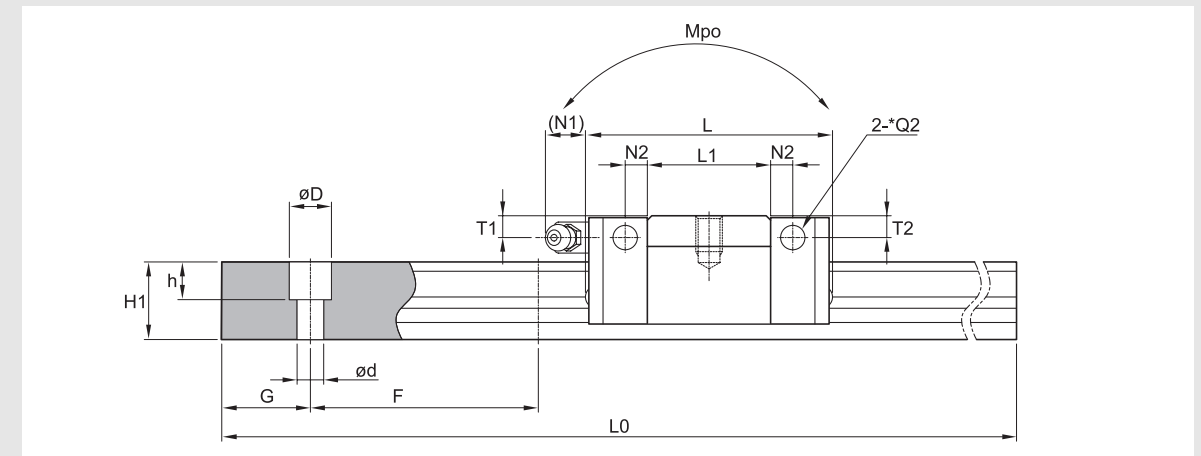
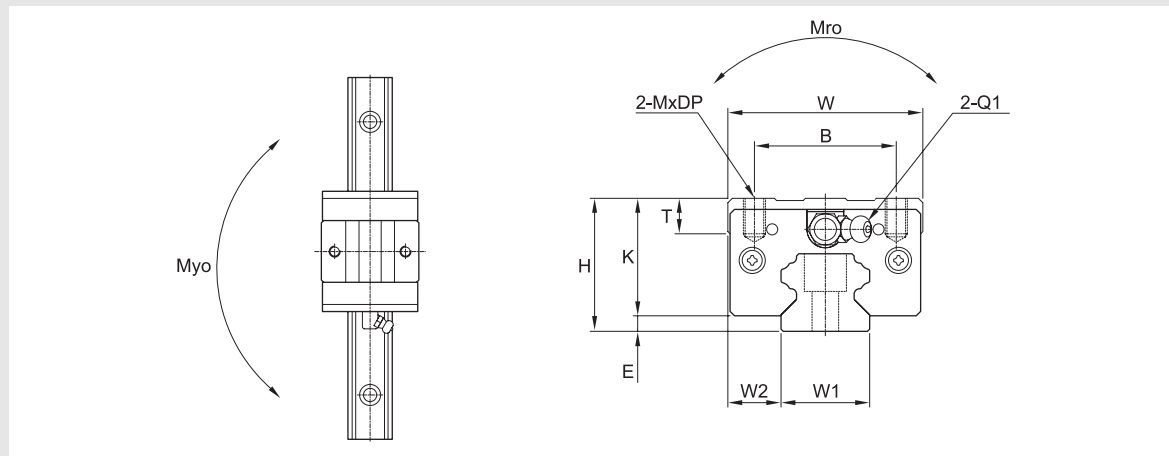

(Unit : mm)

Model	Mounting dimension				Block dimensions											
	H	W	L	E	Mounting tap hole			Grease fitting						Q1	*Q2	
					B	M	DP	L1	T	K	T1	N1	T2			N2
SBS15 SV	24	34	44.9	3	26	M4	5	22.9	6	21	4	5.5	4.5	4.5	M4x0.7	Ø4
SBS20 SV	28	44	54.2	3.5	32	M5	7	27.8	7.5	24.5	5	11.7	5	5	M6x0.75	Ø6
SBS25 SV	33	48	62.6	6.5	35	M6	6	35.2	8	26.5	5.2	11.7	5.1	5.5	M6x0.75	Ø6

Rail dimension									Basic load rating		Permissible static moment			Mass	
W1	W2	H1	F	Bolt hole			G	Max length of rail L0	C	Co	Mro	Mpo	Myo	Block [kg]	Rail [kg/m]
				d	D	h									
15	9.5	15	60	4.5	7.5	5.3	20	3000	4.48	7.23	0.04	0.03	0.03	0.1	1.45
20	12	17.5	60	6	9.5	8.5	20	4000	7.65	13.5	0.12	0.1	0.1	0.19	2.2
23	12.5	21.8	60	7	11	9	20	4000	11.29	21.1	0.19	0.17	0.17	0.32	3.1

① C (Basic dynamic load rating), Co (Basic static load rating)

② \*Q2: The hole of side grease nipple is not made to prevent a foreign substance from going into inside. When you order the side grease nipple, we build it by ourselves.



### Standard and Max. Length of SBG rail

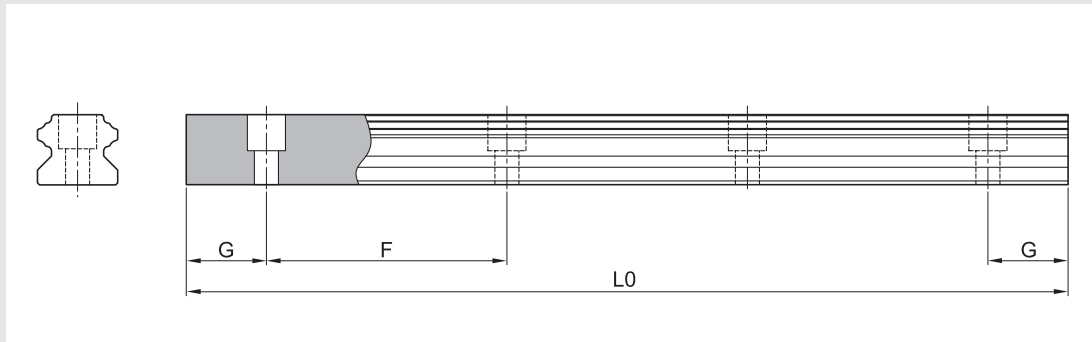

(Unit : mm)

Model number	SBG15	SBG20	SBG25	SBG30	SBG35	SBG45	SBG55	SBG65
Standard length	160	220	220	280	280	570	780	1270
	220	280	280	440	440	885	900	1570
	280	240	340	600	600	1095	1020	2020
	340	460	460	760	760	1200	1140	2470
	460	640	640	1000	1000	1410	1260	2620
	640	820	820	1240	1240	1620	1380	2920
	820	1000	1000	1480	1480	1830	1500	3070
	1000	1240	1240	1640	1640	2040	1620	4000
	1240	1480	1480	1800	1800	2250	1740	
	1480	1600	1600	2040	2040	2460	1860	
	1600	1840	1840	2200	2200	2985	1980	
	1960	2080	2080	2520	2520	3510	2220	
	2200	2200	2200	2840	2840	4000	2580	
	2500	2500	2500	3000	3000		2940	
	2860	2960	2980	3480	3480		3540	
3000	3520	3520	4000	4000		4000		
	4000	4000						
F	60	60	60	80	80	105	120	150
G	20	20	20	20	20	22.5	30	35
L0(Max length)	3,000	4,000	4,000	4,000	4,000	4,000	4,000	4,000

\* The rail for SBG(S), SPG(S) is identical.

\* If the maximum length exceeds this size, butt joints can be supplied.

\* For more information about butt jointing, please refer to the page of safety design.

\* If the G is not standard, please indicate it in the order sheet.

### Bottom mounting rail (SBG-B type)

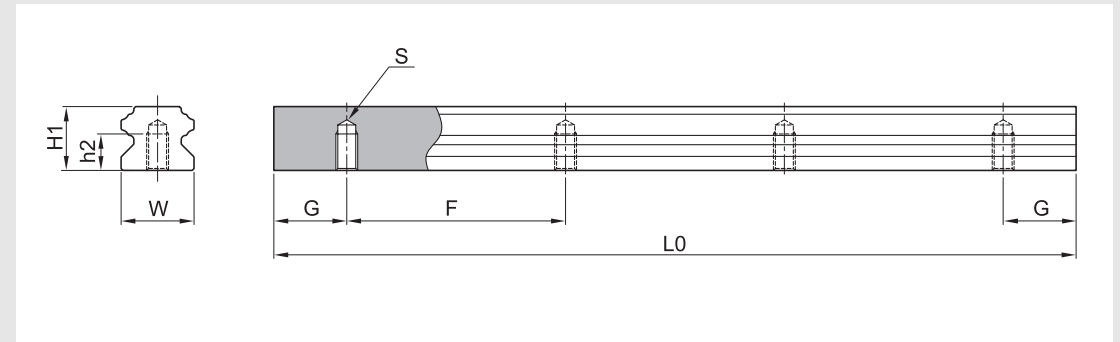

(Unit : mm)

Model number	W1	H1	S	h2	G	F	L0 (Max length)	Weight (kg/m)
SBG 15-B	15	15	M5x0.8	8	20	60	3,000	1.53
SBG 20-B	20	17.5	M6	10	20	60	4,000	2.28
SBG 25-B	23	21.8	M6	12	20	60	4,000	3.21
SBG 30-B	28	25	M8	15	20	80	4,000	4.58
SBG 35-B	34	29	M8	17	20	80	4,000	6.62
SBG 45-B	45	38	M12	24	22.5	105	4,000	11.43

\* The rail for SBG(S), SPG(S) is identical

\* If the maximum length exceeds this size, please contact SBC.



SBG Standard Linear Rail System

SBG Standard Linear Rail System

(1) Standard grease fitting (Front grease fitting)

(Unit : mm)

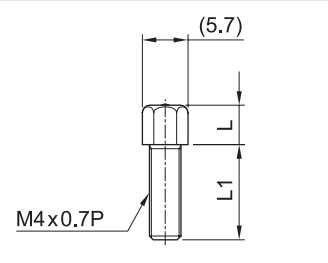

Specification		M4x0.7P		
Applied model	Grease fitting model	Symbol	L	L1
SBG(S) 15	1N	None	7	6
	1D	DD, ZZ	5	9
	1Z	KK	5	11
	1F	MF	5	13

(Unit : mm)

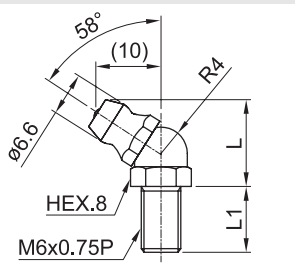

Specification		M6x0.75P, Asia type		
Applied model	Grease fitting model	Symbol	L	L1
SBG(S) 20~35	IA2N	None	14	8
	IA2D	DD, ZZ	14	10
SPG(S) 20~35	IA2Z	KK, MF	14	13
	IA2F	MFDD, MFZZ, MFKK	14	18

(Unit : mm)

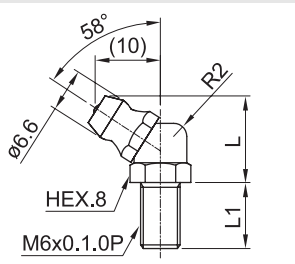

Specification		M6x1.0P, Europe type		
Applied model	Grease fitting model	Symbol	L	L1
SBG(S) 20~35	IE2N	None	14	8
	IE2D	DD, ZZ	14	10
SPG(S) 20~35	IE2Z	KK, MF	14	13
	IE2F	MFDD, MFZZ, MFKK	14	18

(Unit : mm)

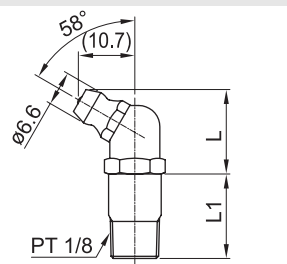

Specification		PT 1/8		
Applied model	Grease fitting model	Symbol	L	L1
SBG(S) 45~65	4N	None	17	13
	4D	DD, KK, ZZ	17	16
	4Z	MF	17	21
	4F	MFDD, MFKK, MFZZ	17	24

(2) Side grease fitting

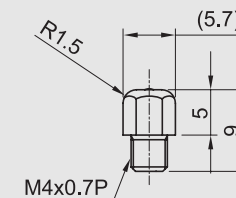

Specification	M4x0.7P
Applied model	SBG(S) 15
Grease fitting model	S1N

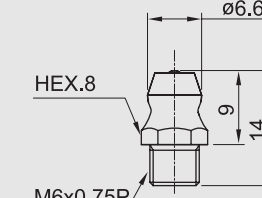

Specification	M6x0.75P
Applied model	SBG(S) 20~45
Grease fitting model	S3N

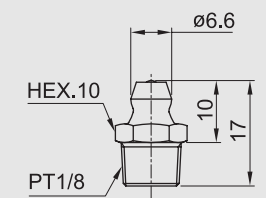

Specification	PT1/8
Applied model	SBG 55~65
Grease fitting model	S4N

(3) FS nipple connector for side grease fitting (FL, FLL flange type only)

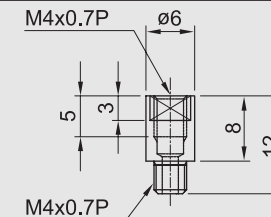

Specification	M4x0.7P
Applied model	SBG(S) 15
Grease fitting model	S1C

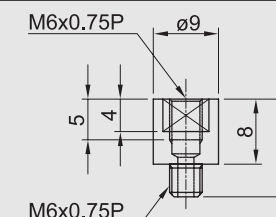

Specification	M6x0.75P
Applied model	SBG(S) 20, 25, 30, 35, 45
Grease fitting model	S4C

\* For size 30~45, two pieces of FS nipple connector are applied.

(4) Copper pipe

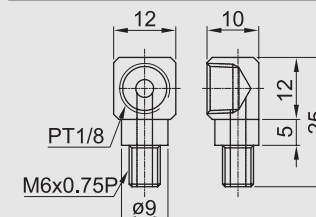

Input size	PT1/8
Output size	M6x0.75P
Applied model	SBG(S), SPG(S) 20
Grease fitting model	S2P

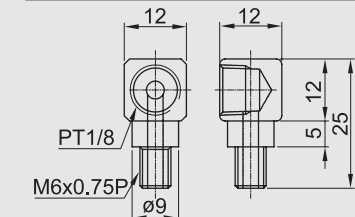

Input size	PT1/8
Output size	M6x0.75P
Applied model	SBG(S), SPG(S) 25~35
Grease fitting model	S3P

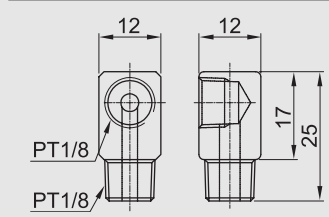

Input size	PT1/8
Output size	PT1/8
Applied model	SBG(S) 45~65
Grease fitting model	S4P



SBG Standard Linear Rail System

SBG Standard Linear Rail System

Accuracy

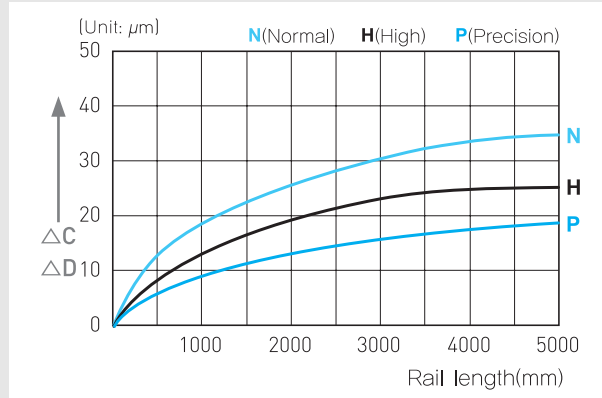
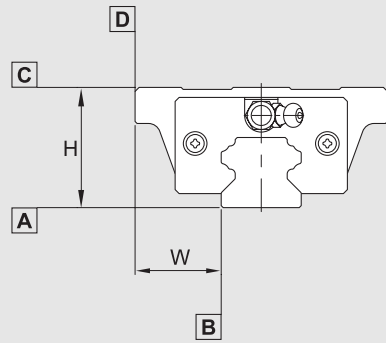

(Unit : mm)

Item	N	H	P
Tolerance for the height H	±0.1	±0.04	±0.02
Tolerance for the rail-to-block lateral distance W2	±0.1	±0.04	±0.02
Tolerance for the height H difference among blocks	0.03	0.015	0.007
Tolerance for rail-to-block lateral distance W2 distance among blocks	0.03	0.015	0.007
Running parallelism of surface C with surface A		ΔC	
Running parallelism of surface D with surface B		ΔD	

• N : Normal • H : High • P : Precision

Preload

Reference	Volume of preload
K1 (Normal)	0.00 ~ 0.02C
K2 (Light)	0.04 ~ 0.06C
K3 (Heavy)	0.08 ~ 0.10C

• C(kN) : Basic dynamic load rating

※ "K3" Preload is not available for SBG, SBS 15 type

Shoulder height and fillet radius R

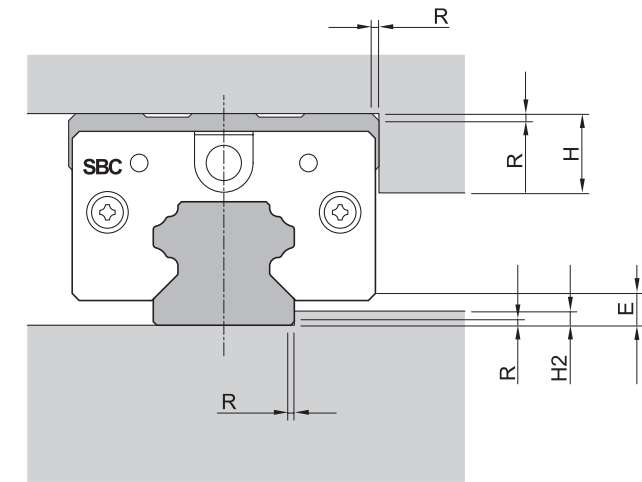

(Unit : mm)

Model number	Fillet radius R	Shoulders height H1	Shoulders height H2	E
15	0.5	4	2	3
20	0.5	5	2.5	3.5
25	1.0	5	3.5	6.5
30	1.0	5	4.5	7
35	1.0	6	6	7.5
45	1.0	8	8	10
55	1.5	8	8	13
65	1.5	10	10	17.5



**SBG Standard Linear Rail System**

**SBG Standard Linear Rail System**

**RC Cap**

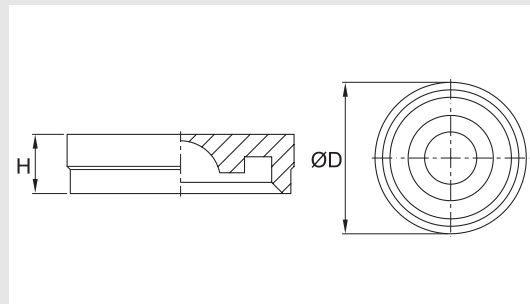

(Unit : mm)

Model	D±0.1	H±0.1
RC 15	7.6	1.3
RC 20	9.6	3.5
RC 25	11.1	2.8
*RC 30	14.2	3.7
RC 45	20.2	4.7
RC 55	23.2	6
RC 65	26.2	6

- RC 30 is used for SBG 30, 35 rail.
- SBI, SBG type use same RC cap.

**ST Tape**

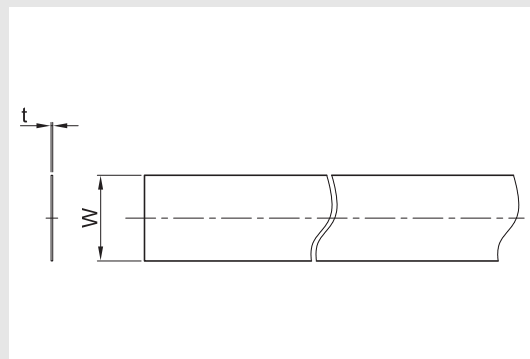

(Unit : mm)

Model	W	t
ST 15	8.3	0.1
ST 20	11	0.1
ST 25	13	0.1
ST 30	17	0.1
ST 35	21	0.1
ST 45	30	0.1
ST 55	34	0.1
ST 65	40	0.1

Ordering example : **ST15 - 1000L**

①      ②

- ① Model number
- ② Length

- Equivalent rail is used for SBG, SBS, SPG, SPS

**Seal and MF container**

[Method and overall length with each seal]

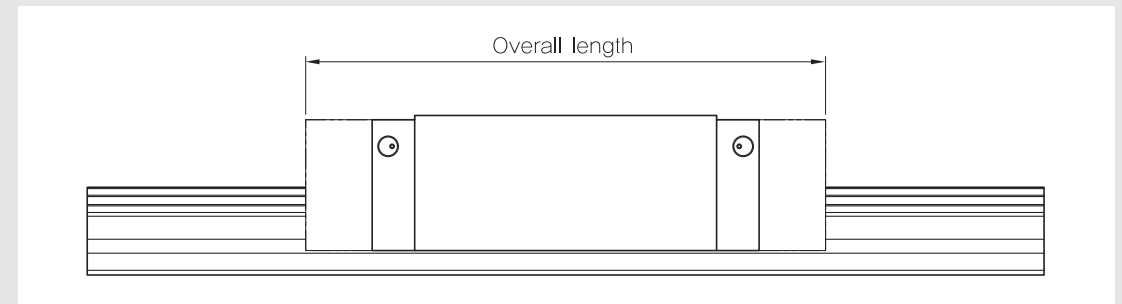

• E : End seal    S : Scraper    F : MF (Self lubricant)    (Unit : mm)

Additional seal	Standard	DD	ZZ	KK	MF	MFDD	MFZZ	MFKK
Indication of seal	E	E+E	E+S	E+E+S	F+E	F+E+E	F+E+S	F+E+E+S
Overall length with seal	15	60.8	66.8	65.2	71.2	-	-	-
	15V	44.9	50.9	49.3	55.3	-	-	-
	20	77.2	83.6	82.6	89	93.2	99.6	98.6
	20L	93.2	99.6	98.6	105	109.2	115.6	114.6
	20V	54.2	60.6	59.6	66	70.2	76.6	75.6
	25	86.9	93.3	92.7	99.1	102.9	109.3	108.7
	25L	106.4	112.8	112.2	118.6	122.4	128.8	128.2
	25V	62.6	69	68.4	74.8	78.6	85	84.4
	30	100	104.6	105.4	110	116	120.6	121.4
	30L	122.5	127.1	127.9	132.5	138.5	143.1	143.9
	35	112.6	117.2	117.4	122	128.6	133.2	133.4
	35L	138.1	142.7	142.9	147.5	154.1	158.7	158.9
	45	140.3	145.1	145.2	150	156.3	161.1	161.2
	45L	172.3	177.1	177.2	182	188.3	193.1	193.2
	55	166.8	172.8	170.4	176.4	-	-	-
	55L	204.8	210.8	208.4	214.4	-	-	-
65	195.2	201.2	202.4	208.4	-	-	-	
65L	255.2	261.2	262.4	268.4	-	-	-	

- Bottom seal of SBG(S) type is integrated with bottom retainer. (Except SBG, SBS15)
- If block is assembled with MF container, the grease fitting is not supplied. If you would like to feed the grease to the block, please order side grease fitting type.



SBG Standard Linear Rail System

SBG Standard Linear Rail System

[Dimension of MF container]

(Unit : mm)

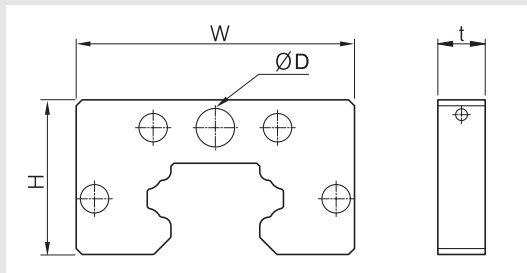

Reference	Model	W	t	H	D
MF	20	43	8	24	6.5
	25	47	8	26.1	6.5
	30	59	8	34.5	6.5
	35	68	8	40	6.5
	45	84	8	49	8.5

※ Container is available for SBG(S), SPG(S) 20-45

[Seal resistance]

For the maximum value of seal resistance of SBG standard type per block, in which grease is not applied.

※ Scraper has no resistance because it is not contacting rail.

(Unit : N)

Model	End seal	MF
SBG 15	1.96	-
SBG 20	2.58	1.61
SBG 25	3.92	4.21
SBG 30	7.84	6.37
SBG 35	11.76	7.06
SBG 45	19.6	7.35
SBG 55	19.6	-
SBG 65	34.3	-

HT high temperature end plate

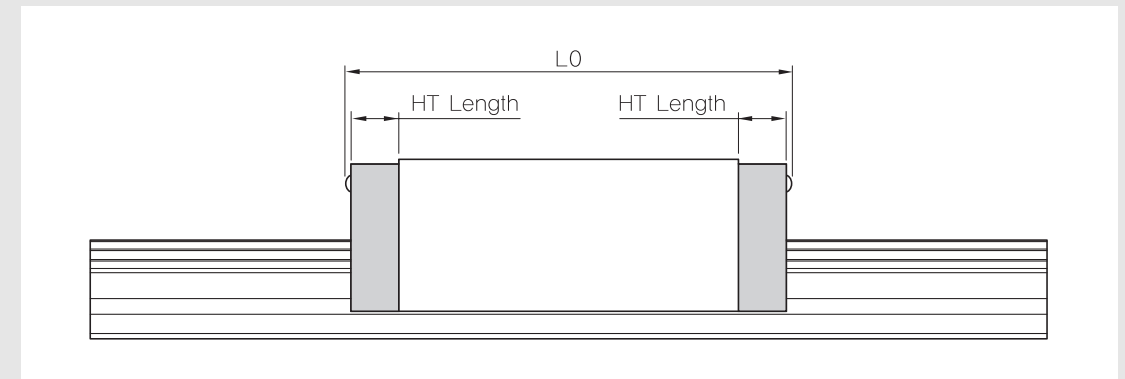

(Unit : mm)

Reference	HT Length	Overall length					
		Applied model	LO	Applied model	LO	Applied model	LO
HT 15	8	SBG(S) 15	54.8	-	-	SBS 15V	38.9
HT 20	10	SBG(S) 20	70.8	SBG(S) 20L	86.8	SBS 20V	47.8
HT 25	10.5	SBG(S) 25	83.9	SBG(S) 25L	103.4	SBS 25V	59.6
HT 30	11.5	SBG(S) 30	98.4	SBG(S) 30L	120.9	-	-
HT 35	12	SBG(S) 35	110.4	SBG(S) 35L	135.9	-	-
HT 45	16	SBG(S) 45	138	SBG(S) 45L	170	-	-
HT 55	18	SBG(S) 55	162	SBG(S) 55L	200	-	-
HT 65	18	SBG(S) 65	194	SBG(S) 65L	254	-	-

Ordering example : **SBG25FL - HT - 2 - K1 - 800 - N**

① ② ③ ④ ⑤ ⑥

- ① Model
- ② High temperature end plate
- ③ Block quantity
- ④ Preload
- ⑤ Rail length
- ⑥ Accuracy

※ All plastic components are replace with steel or aluminum in the High Temperature Blocks.

※ Side grease fitting is not available for high temperature end plates

Grease and nipple specification

[Grease]

SBG uses two types of grease according to working conditions. For details, please see the technical data for grease.