

## Instruction Manual Compact AC Geared Motor International Standards Certified

- Thank you for purchasing the Panasonic product.
- Please review the material in this manual thoroughly before using the motor.
- **It is especially important that you carefully read "Safety Precautions" (pp.2 to 4) so that you will properly and safely use the product.**
- This product is for industrial equipment. Don't use this product at general household.  
Keep this manual in a safe location so you can refer to it as you need.



The user and operator should always refer to this manual.

### • Contents



	page		page
<b>Safety Precautions</b> .....	<b>2</b>	<b>4. Operation</b> .....	<b>34</b>
<b>1. Introduction</b> .....	<b>5</b>	<b>5. Inspection and maintenance</b> .....	<b>36</b>
General .....	5	<b>6. Troubleshooting</b> .....	<b>37</b>
Unpacking .....	5	<b>7. Specification</b> .....	<b>37</b>
Model identification .....	6	<b>8. Compatible with international standards ...</b>	<b>38</b>
Description of model number .....	7	Peripherals layout practices .....	39
Names and functions .....	8	Wiring peripherals .....	39
<b>2. Installation</b> .....	<b>9</b>	Conformance to UL and CSA .....	39
Motor .....	9	<b>9. After-Sale Service (Repair)</b> .....	<b>40</b>
Capacitor (single-phase motor only) .....	11		
Gear head .....	11		
Verifying load and use condition .....	15		
<b>3. Wiring</b> .....	<b>30</b>		

# Safety Precautions



Please observe safety precautions fully.

The following explanations are for things that must be observed in order to prevent harm to people and damage to property.

- Misuses that could result in harm or damage are shown as follows, classified according to the degree of potential harm or damage.

	<b>Danger</b>	Indicates great possibility of death or serious injury.
	<b>Caution</b>	Indicates the possibility of injury or property damage.

- The following indications show things that must be observed.

	Indicates something that must not be done.
	Indicates something that must be done.

## Danger

	Don't expose the equipment to water, corrosive environment or flammable gas or close to flammable material.	Will cause fire.
	Don't place a flammable object close to the motor.	
	Don't damage leadwires or subject leadwires to excessive stress such as strong pressure, heavy object and clamping load.	Will cause electric shock, malfunction or damage.
	Don't use leadwires soaked in water or oil.	
	Don't use the motor in a place subject to excessive vibration or shock.	Will cause electric shock, personal injury or fire.
	Don't drive the 380/400 VAC three-phase motor from the inverter.	Will cause electric shock, personal injury, fire, malfunction or damage.
	Don't touch rotating member of the motor.	Will cause personal injury.
	Don't touch potentially hot motor casing.	Will cause burn injury.
	Don't attempt to carry out wiring or manual operation with wet hand.	Will cause electric shock, personal injury or fire.

	Wiring work should be done by a qualified electrician.	Wiring work done by an inexperienced person will cause electric shock.
	Use overcurrent protection device, ground-fault circuit interrupter, overtemperature protecting device, and emergency stop device.	Failure to heed these requirements will result in electric shock, personal injury or fire.
	After an earthquake, first verify safety.	
	Before transferring, wiring or checking, disconnect the power source from the motor system for safe isolation.	Energized circuit will cause electric shock.
	Securely install the equipment to prevent bodily injury or fire in case of earthquake.	Failure to heed this requirement will result in electric shock, personal injury, fire, malfunction or damage.
	Provide emergency stop circuit externally for instantaneous interruption of operation and power supply.	
	Install the unit to a nonflammable construction (e.g. metal).	Installation on a flammable material may cause fire.
	Installation area should be free from excessive dust, and from splashing water and oil.	Failure to heed this precaution will result in electric shock, personal injury, fire, malfunction or damage.
	Correctly run wirings to the external speed setter and tacho-generator.	Incorrect wiring will result in short circuit, electric shock, personal injury, etc.
	Turn off power upon power interruption or activation of overtemperature protecting device.	Unpredictable restarting will cause personal injury.
	After correctly connecting leadwires, insulate the live parts with insulator.	Incorrect wiring will result short circuit, electric shock, fire or malfunction.
	Ground the motor to the earth.	Floating ground circuit will cause electric shock.



## Caution

	Don't move the motor by holding leadwires or motor shaft.	Failure to heed these precautions will cause bodily injury.
	Don't put the machine into unstable operation.	
	Once power failure occurs, don't come close to the machine that will unexpectedly start upon recovery of the power.	
	Provide secure mechanism so that the restarting of the machine will not cause personal injury.	
	Don't apply excessive shock to the motor shaft.	Excessive shock will cause failure.
	Don't apply excessive shock to the product.	
	Don't get on the product. Don't place heavy object on the product.	Failure to heed this instruction will result in electric shock, personal injury, fire, malfunction or damage.
	Don't lock the motor shaft while the motor is running.	Locked motor will cause fire, electric shock, or malfunction.

# Safety Precautions

Please observe safety precautions fully.

## Caution

	Don't put an object or finger into the motor opening.	Failure to heed this instruction will result in electric shock or fire.
	Don't turn off and on power so frequently.	Failure to heed this instruction will result in fire, personal injury, malfunction or damage.
	Don't pull leadwires with an excessive force.	Failure to heed this instruction will cause fire, electric shock or personal injury.
	Don't use the equipment in highly intensive electric field.	Failure to heed these instructions will cause personal injury or fire.
	Don't use the equipment under direct sunshine.	
	Don't use the equipment in an environment where electro-static voltage potentials may be produced.	Induced malfunction will cause malfunction or personal injury.
	Don't drop or cause topple over of something during transportation or installation.	Failure to heed this instruction will result in personal injury or malfunction.
Never attempt to perform modification, dismantle or repair.	Failure to heed this instruction will result in fire, electric shock, personal injury or malfunction.	
	Perform installation by taking into consideration the mass of the body and rated output of the product.	Failure to heed these requirements will result in personal injury or malfunction.
	Adjust the motor ambient environmental condition to match the motor operating temperature and humidity.	
	Exactly follow the installing method and direction specified.	
	Connect a ground-fault interrupter, molded case circuit breaker and replay to the brake control relay in series so that they are turned off upon emergency stop.	Missing of one of these devices will cause malfunction.
	Test-run the securely fixed motor without loading to verify normal operation, and then connect it to the mechanical system.	Operation using a wrong model or wrong wiring connection will result in personal injury.
	Level of input voltage to peripheral devices should correspond to the motor rated voltage.	Operation from a voltage outside the rated voltage will cause electric shock, personal injury or fire.
	Provide protection device against idling of electro-magnetic brake or gear head, or grease leakage from gear head.	No protection will cause personal injury, damage, pollution or fire.
	Don't place any obstacle object around the motor and peripheral, which blocks air passage.	Temperature rise will cause burn injury or fire.
	Correctly run and arrange wiring.	Wrong wiring will cause personal injury or electric shock.
	Maintenance must be performed by an experienced personnel.	
Always keep power disconnected when the power is not necessary for a long time.	Improper operation will cause personal injury.	
Scraps must be treated as industrial waste.		

# 1. Introduction

## General

This is a compact AC geared-motor having multiple international standard certifications. To use this product for a prolonged period, read this manual thoroughly. This is designed for use in corporation with general purpose industrial devices. The product must be handled by experienced personnel familiar with the product.

### <note>

When export this product, follow statutory provisions of the destination country.

## Unpacking

### • Proceed as follows:

- First open the top of the packing and check the units for damage in transit.
- Check the motor nameplate for the model number, output, No. of poles, voltage, frequency, etc.  
Do not use the product if it does not meet your specification (if you dare to use it, burn injury or fire may result).
- A single-phase motor comes with capacitor and capacitor cap. Check the rated capacitance and voltage on the nameplate. Do not use the accessory capacitor if it does not meet your specification (if you dare to use it, you may be injured or may have fire).
- Gear head is optional.
- Check a gear ratio on the nameplate. Do not use it if it does not meet your specification (if you dare to use it, you may be injured or may have fire).

**Should you find any discrepancy in the product, consult your local dealer.**

# 1. Introduction

## Model identification

### Designation and rating information on the nameplate

- Below shows a sample of nameplate, a single-phase induction motor (90 W).  
Note: Format of nameplate is not common to all models.

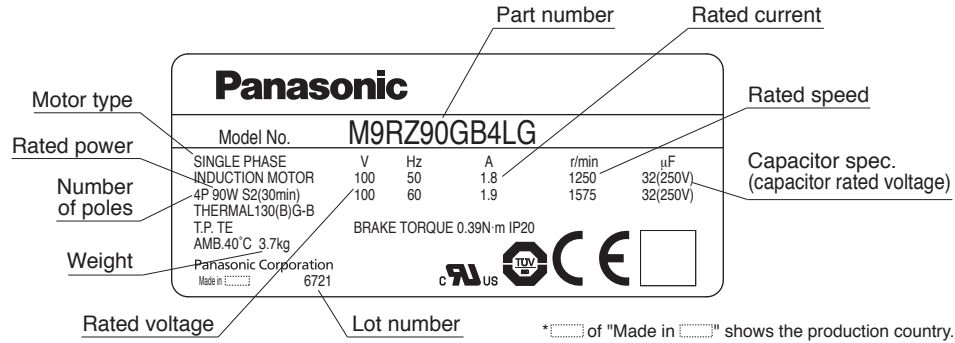

### <Type of motor>

- SINGLE PHASE INDUCTION MOTOR**  
Capacitor motor : Induction motor, Reversible motor
- THREE PHASE INDUCTION MOTOR**  
: Three phase Induction motor

- Below shows a sample of gear head Sq.90 mm 1/18

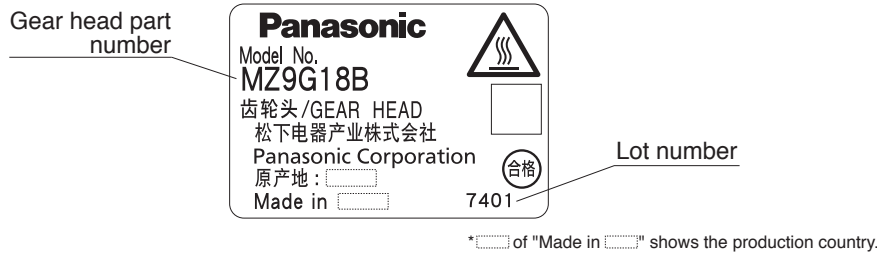

### Designation of lot number

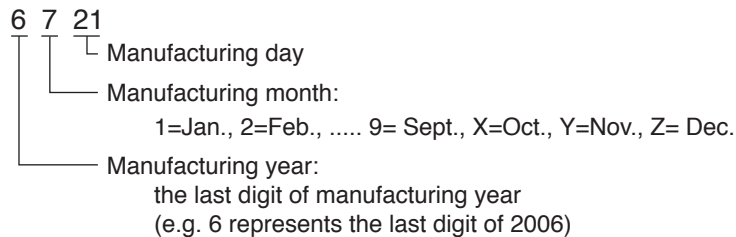

## Description of model number

### Motor

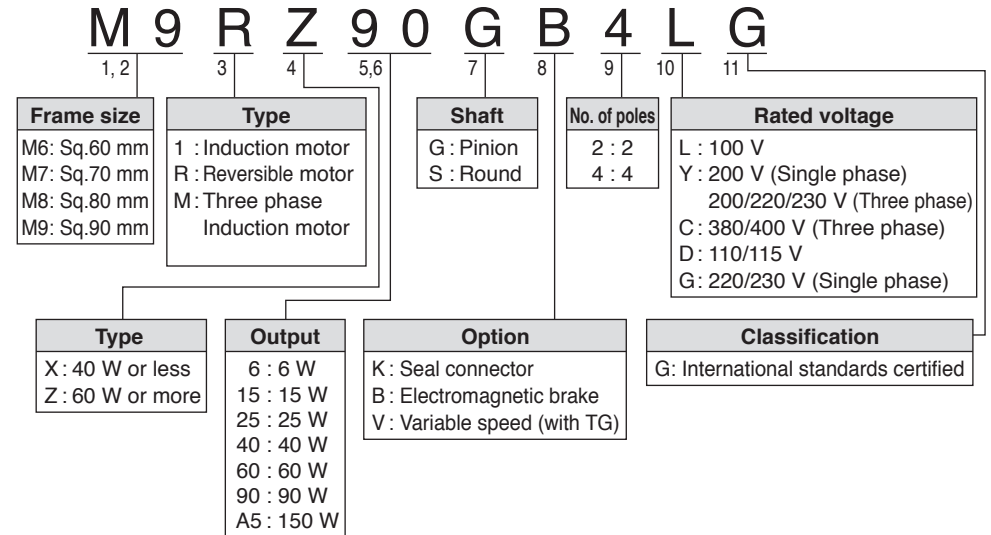

\* Induction motor and reversible motor are single phase motor.

### Gear head

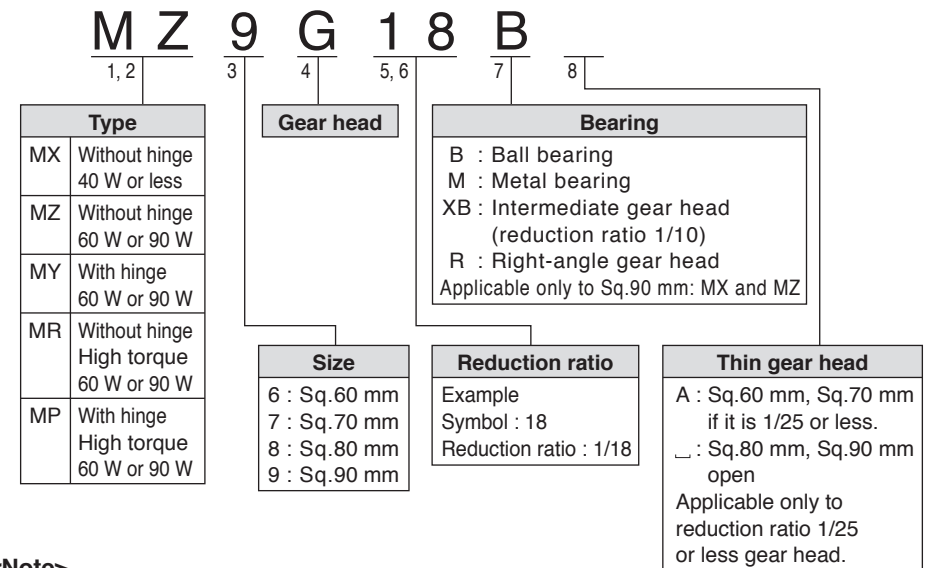

### <Note>

Gear head is optional. For further information refer to your local dealer.

# 1. Introduction

## Names and functions

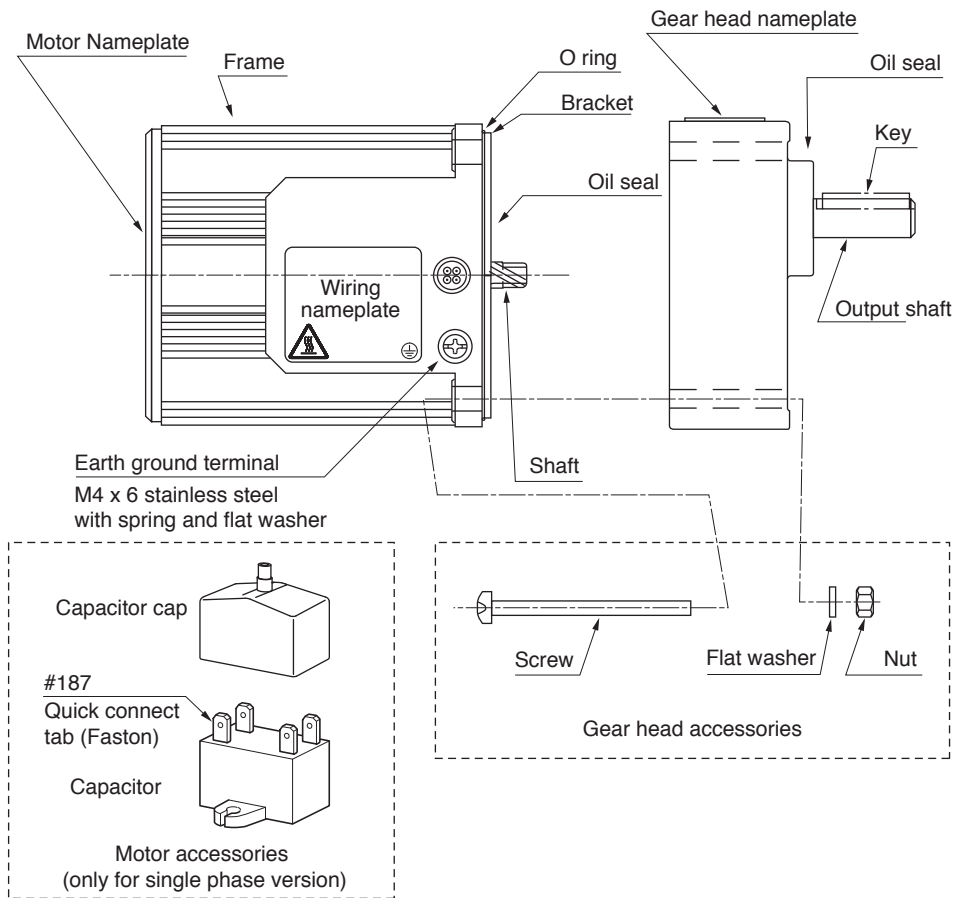

\* Don't remove the nameplate.

# 2. Installation

## Motor

### Installation location

- Install the motor as described to prolong the motor lifetime in a place where;
- (1) is free from rain and direct sunlight.
  - (2) is free from vibration  $4.9 \text{ m/s}^2$  or more; shock, dust, iron powder or oil mist; splash of water, oil and grinding fluid; and away from flammable materials, corrosive gas ( $\text{H}_2\text{S}$ ,  $\text{SO}_2$ ,  $\text{NO}_2$ ,  $\text{Cl}_2$ , etc.) or flammable gas.
  - (3) is enough ventilated dry and clean keeping oil, water, dust and heat away.
  - (4) you can check and clean the motor easily.
  - (5) is not in a closed environment where the motor temperature may increase. This may result in the motor life shortened.

### Environmental condition

Item	Description
Ambient temperature	$-10 \text{ }^\circ\text{C}$ to $40 \text{ }^\circ\text{C}$ (no freezing) *1
Ambient humidity	85% RH or below (no dewing)
Storage temperature	$-10 \text{ }^\circ\text{C}$ to $60 \text{ }^\circ\text{C}$ (no freezing) *2
Vibration	$4.9 \text{ m/s}^2$ or below (10 to 60 Hz)
Altitude	Lower than 1000 m.

\*1) Measurement taken at a point 5 cm from the motor.

\*2) Allowable range for a relatively short period, for example, during transportation.

### Installation

The motor can be installed vertically or horizontally but leadwires should be directed downward.

### Keep the motor away from oil, water and dust

- (1) Don't run the cable in water or oil.
- (2) Don't expose the motor to splashing oil or water.

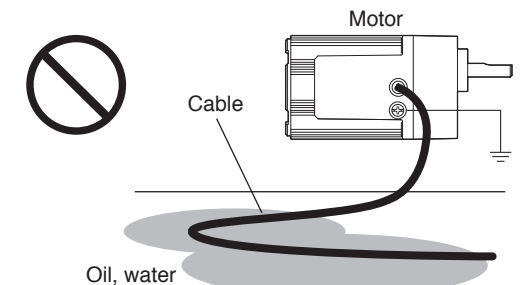

## 2. Installation

### Stress on lead

Do not stress where a cable coming out on the motor housing and where the cable is connected.

### Output shaft allowable load

- (1) Design the mechanical system so that it can withstand the radial load and thrust load allowed to be applied to the shaft of the specified model during installation and operation.
- (2) When installing a rigid coupling, pay special attention to minimize bending load that may cause damage to the shaft or shorten the life of bearings.
- (3) To keep the radial load caused by center runout within the tolerance, use high stiffness flexible coupling.

### Installation guidelines

- (1) Don't directly apply shocks to the shaft by a hammer during installation/removal of the coupling.
- (2) Perform exact centering: eccentric shaft revolution will cause vibration and damage bearing.
- (3) Keep the surface temperature of the frame at 90 °C or below (at ambient temperature 40 °C).
  - A motor with pinion shaft must be used with a gear head.
  - A motor with round shaft must be used by being attached to an application to take a heat out of the motor.

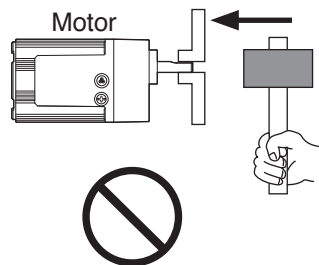

### <Remarks>

Size of heat sink

Motor size (part No.)	Size of heat sink	Material of heat sink
Sq.60 mm (M6...)	100 x 100 x 5	Aluminum
Sq.70 mm (M7...)	120 x 120 x 5	Aluminum
Sq.80 mm (M8...)	135 x 135 x 5	Aluminum
Sq.90 mm (M9*X...) (M9*Z...)	165 x 165 x 5	Aluminum
	195 x 195 x 5	Aluminum

\* The winding temperature measured using the resistance method after the rated operation with a heat sink shown above should be 80 K or below.

## Capacitor (single-phase motor only)

### Mounting

Secure the capacitor using M4 screw (Not come with the motor). (Recommended torque to tighten : 0.74 to 1.0 N·m)

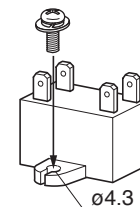

## Gear head

### Gear head setting to a motor

#### • Preparation

- (1) Prepare a gear head that matches a motor described in this manual. Use of incompatible gear head will cause malfunction.
- (2) Check O-ring being correctly placed in a right place. If it is not, this may result in grease in the gear head coming out.
- (3) Wipe off any grease on the gear head flange surface.

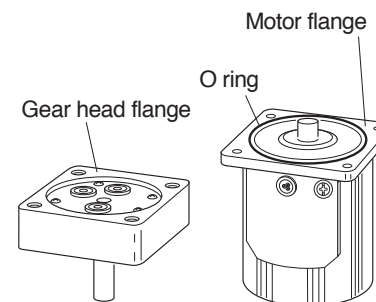

## 2. Installation

### • Assembling

- (1) Place the unit so that the motor shaft faces up.

Direction of the motor lead and output shaft of gear head must match an application.

- (2) Do not contact a tooth tip of pinion shaft to a tooth tip of gear head.

Set each toothes of motor and gear head correctly and gently press and turn the gear head in counter and counter-clockwise.

- (3) To attach the gear head to an application, **use the "attaching screws" supplied with the gear head** and tighten the screws with appropriate torque and with care not to pinch the O ring, so that there is no gap between motor flange and gear flange.

The recommended torque is shown below.

Flange size (mm)	Screw size	Tightening torque
60	M4	2 to 2.5 N·m
70	M5	2.5 to 3 N·m
80	M5	2.5 to 3 N·m
90	M6	3.5 to 4.5 N·m

- (4) Tighten the screws correctly.

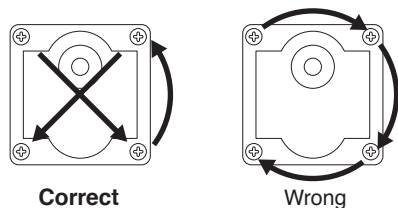

#### <Note>

Do not forcedly assemble the motor and gear head. Do not damage the tooth of the motor pinion and gear head.

Incorrect assembly results in abnormal noise generation or shortened unit life.

 DON'T	<b>Don't touch screws on the output shaft of gear head.</b>	Will cause malfunction.
-----------	---	-------------------------

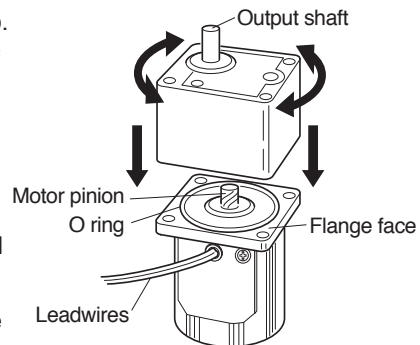
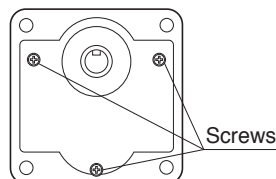

Assemble the motor shaft facing up.

### • Assembling intermediate gear head

Follow the same steps described to install a gear head on page-12.

Screws to set the intermediate gear do not come with the gear head. The screws are available as an optional accessories at your local dealer.

<Intermediate gear head>

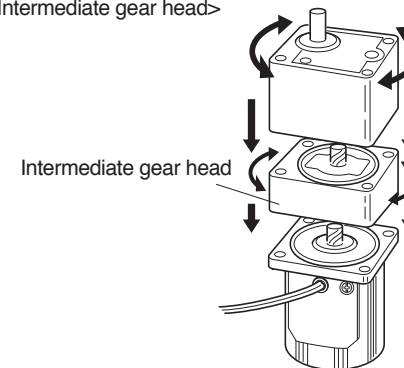

### • Assembling gear head with 90 mm hinge (MY, MP type)

When attaching a gear head with 90 mm hinge, follow the steps described previously but use the screws associated with the gear head. To install the gear head to an application, the customer is responsible for preparing necessary bolts, nuts and flat washers. (M8, hinge mounting pitch 36 mm x 110 mm, tightening torque 10 N·m)

<Gear head with hinge>

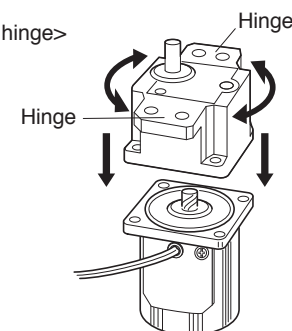

## 2. Installation

### Considerations for installation of gear head

You may experience a slipping gear contact due to broken pinion tooth, locked gear or leaked grease as the gear head life comes closer.

Place a safety device to keep safe operation at any time even if such problems take place.

- Place a drop-proof device in an vertically motioned application like a lifter.
- Place a device to open the door in a door application just in case the gear head is locked.
- Place an oil pan to prevent oil from coming out in an application like food/textile etc.
- Do not place an encoder, sensor, contact, etc near a gear head where the grease may leaking out. If not, please have a protection from grease.
- Have a routine check of the gear head to avoid unexpected accident.

### <Precautions>

Keep the gear head attached to the motor. Otherwise, the O ring may become distorted or damaged, causing grease leakage.

- When reassembling, first replace the O ring with a new one.
- When installing a motor associated with the gear head to the application device, temporarily secure the motor and gear head with a tape until assembly completes.

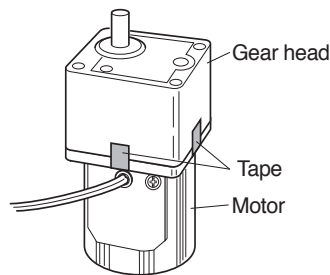

\* For the O ring (spare part), refer to the catalog or the motor technical information available via Internet as described on the last page of this document.

### Considerations for storage of gear head

When storing the gear head as a single unit, place it with the output shaft facing down.  
(To prevent grease leakage)

### Verifying load and use condition

To use your equipment for a long period, check the use condition. Some specific conditions will cause heat rise or damage. Check the conditions and use the units within the allowable range.

#### • Standard life

The table right shows the standard life of motor with a gear head. The typical life of a motor (round shaft) is 10000 hours. Standard life of oil seal (pinion shaft type) performance is 5000 hours. The standard life is calculated under conditions; 8 hours operation per day(service factor : Sf=1.0) Ambient temperature and humidity

Gear head type	Standard life
MX6G*B(A) thru MX9G*B MZ9G*B, MY9G*B MR9G*B, MP9G*B	10000 hours
MX9G*R MZ9G*R	5000 hours
MX6G*M(A) thru MX9G*M	2000 hours

“ \* ” in model number represents gear ratio.

Constant load(allowable gear head shaft torque).

#### • Service factor (Sf)

$$\text{Life expectancy} = \frac{\text{Standard life}}{\text{Service factor (Sf)}}$$

The service factor (Sf) varies depending on the intensity of load shock and operating hours. The table below shows the loading conditions and corresponding service factors.

Type of load	Example of load	Service factor		
		5 hours/day	8 hours/day	24 hours/day
Uniform load	Continues one way operation	0.8	1.0	1.5
Light impact	Start, stop, cam impact	1.2	1.5	2.0
Medium impact	Instant CW/CCW, instant stop	1.5	2.0	2.5
High impact	Frequent repetition of medium impact	2.5	3.0	3.5

#### • Allowable shaft torque

The required allowable shaft torque TA of the gear head can be determined based on the service factor and actual load torque T1:

$$TA = T1 \times Sf$$

Select a gear head and motor so that the required torque (continuous value) is within the range shown in the table below. Note that torque T1 is not allowed to exceed the allowable shaft torque TA regardless of Sf.



## 2. Installation

### Allowable shaft torque with gear head directly connected

\* The number of revolutions is calculated based on the synchronous rotating speed (1500 r/min, 1800 r/min).  
Usually, actual speed is slow by 2 to 20% the value shown in the table, depending on load condition.

#### • Sq.60 mm/6 W

Allowable shaft torque: upper line = **N·m**, lower line = **kgf·cm**

Speed reduction ratio		3	3.6	5	6	7.5	9	10	12.5	15	18	20	25											
Rotating speed (r/min)	50 Hz	500	416.7	300	250	200	166.7	150	120	100	83.3	75	60	50	41.7	30	25	20	16.7	15	12.5	10	8.3	
	60 Hz	600	500	360	300	240	200	180	144	120	100	90	72	60	50	36	30	24	20	18	15	12	10	
Applicable gear head	MX6G3BA– MX6G180B (Ball bearing)	50 Hz	0.098 (1.0)	0.12 (1.2)	0.16 (1.6)	0.19 (1.9)	0.25 (2.6)	0.29 (3.0)	0.33 (3.4)	0.40 (4.1)	0.49 (5.0)	0.59 (6.0)	0.66 (6.7)	0.79 (8.1)	0.95 (9.7)	1.18 (12)	1.57 (16)	1.86 (19)	2.25 (23)	2.45 (25)	2.45 (25)			
	MX6G3MA– MX6G180M (Metal bearing)	60 Hz	0.081 (0.83)	0.098 (1.0)	0.13 (1.3)	0.16 (1.6)	0.21 (2.1)	0.25 (2.6)	0.26 (2.7)	0.33 (3.4)	0.40 (4.1)	0.49 (5.0)	0.53 (5.4)	0.66 (6.7)	0.79 (8.1)	0.95 (9.7)	1.27 (13)	1.57 (16)	1.86 (19)	2.25 (23)	2.45 (25)			
Rotation direction		Same as on the motor											Opposite to that of the motor											

#### • When intermediate gear head is used

Applicable gear head		Speed reduction ratio	200	250	300	360	500										
Bearing	Intermediate gear head	Rotating speed (r/min)	50 Hz	7.5	6	5	4.2	3	2.5	2	1.7	1.5	1.3	1	0.8		
			60 Hz	9	7.2	6	5	3.6	3	2.4	2	1.8	1.5	1.2	1		
MX6G*BA (Ball bearing) MX6G*B (Ball bearing) MX6G*MA (Metal bearing) MX6G*M (Metal bearing)	MX6G10XB	Allowable shaft torque	<b>N·m</b> (kgf·cm)	2.45 (25)	2.45 (25)	2.45 (25)	2.45 (25)	2.45 (25)	2.45 (25)	2.45 (25)	2.45 (25)	2.45 (25)	2.45 (25)	2.45 (25)	2.45 (25)		
Rotation direction		Same as on the motor							Opposite to that of the motor								

#### • Sq.70 mm/15 W

Allowable shaft torque: upper line = **N·m**, lower line = **kgf·cm**

Speed reduction ratio		3	3.6	5	6	7.5	9	10	12.5	15	18	20	25										
Rotating speed (r/min)	50 Hz	500	416.7	300	250	200	166.7	150	120	100	83.3	75	60	50	41.7	30	25	20	16.7	15	12.5	10	8.3
	60 Hz	600	500	360	300	240	200	180	144	120	100	90	72	60	50	36	30	24	20	18	15	12	10
Applicable gear head	MX7G3BA– MX7G180B (Ball bearing)	50 Hz	0.24 (2.5)	0.28 (2.9)	0.39 (4.0)	0.47 (4.8)	0.59 (6.0)	0.71 (7.2)	0.80 (8.2)	0.98 (10)	1.18 (12)	1.37 (14)	1.57 (16)	1.86 (19)	2.25 (23)	2.74 (28)	3.82 (39)	4.61 (47)	4.90 (50)	4.90 (50)			
	MX7G3MA– MX7G180M (Metal bearing)	60 Hz	0.20 (2.0)	0.24 (2.5)	0.32 (3.3)	0.39 (4.0)	0.49 (5.0)	0.59 (6.0)	0.66 (6.7)	0.81 (8.3)	0.98 (10)	1.18 (12)	1.27 (13)	1.57 (16)	1.86 (19)	2.25 (23)	3.23 (33)	3.82 (39)	4.80 (49)	4.90 (50)			
Rotation direction		Same as on the motor											Opposite to that of the motor										

#### • When intermediate gear head is used

Applicable gear head		Speed reduction ratio	200	250	300	360	500										
Bearing	Intermediate gear head	Rotating speed (r/min)	50 Hz	7.5	6	5	4.2	3	2.5	2	1.7	1.5	1.3	1	0.8		
			60 Hz	9	7.2	6	5	3.6	3	2.4	2	1.8	1.5	1.2	1		
MX7G*BA (Ball bearing) MX7G*B (Ball bearing) MX7G*MA (Metal bearing) MX7G*M (Metal bearing)	MX7G10XB	Allowable shaft torque	<b>N·m</b> (kgf·cm)	4.90 (50)	4.90 (50)	4.90 (50)	4.90 (50)	4.90 (50)	4.90 (50)	4.90 (50)	4.90 (50)	4.90 (50)	4.90 (50)	4.90 (50)	4.90 (50)		
Rotation direction		Same as on the motor							Opposite to that of the motor								

## 2. Installation

### Allowable shaft torque with gear head directly connected

\* The number of revolutions is calculated based on the synchronous rotating speed (1500 r/min, 1800 r/min).  
Usually, actual speed is slow by 2 to 20% the value shown in the table, depending on load condition.

#### • Sq.80 mm/25 W

Allowable shaft torque: upper line = **N·m**, lower line = **kgf·cm**

Speed reduction ratio		3	3.6	5	6	7.5	9	10	12.5	15	18	20	25											30	36	50	60	75	90	100	120	150	180	
Rotating speed (r/min)	50 Hz	500	416.7	300	250	200	166.7	150	120	100	83.3	75	60											50	41.7	30	25	20	16.7	15	12.5	10	8.3	
	60 Hz	600	500	360	300	240	200	180	144	120	100	90	72											60	50	36	30	24	20	18	15	12	10	
Applicable gear head	<b>MX8G3B– MX8G180B</b> (Ball bearing)	50 Hz	0.39 (4.0)	0.47 (4.8)	0.66 (6.7)	0.78 (8.0)	0.98 (10)	1.18 (12)	1.27 (13)	1.57 (16)	1.96 (20)	2.35 (24)	2.55 (26)	3.14 (32)											3.82 (39)	4.61 (47)	6.37 (65)	7.64 (78)	7.84 (80)					
	<b>MX8G3M– MX8G180M</b> (Metal bearing)	60 Hz	0.32 (3.3)	0.39 (4.0)	0.55 (5.6)	0.66 (6.7)	0.81 (8.3)	0.98 (10)	1.08 (11)	1.27 (13)	1.57 (16)	1.96 (20)	2.06 (21)	2.65 (27)											3.14 (32)	3.82 (39)	5.29 (54)	6.37 (65)	7.84 (80)					
Rotation direction		Same as on the motor											Opposite to that of the motor																					

#### • When intermediate gear head is used

Applicable gear head		Speed reduction ratio	200	250	300	360	500											600	750	900	1000	1200	1500	1800		
Bearing	Intermediate gear head	Rotating speed (r/min)	50 Hz	7.5	6	5	4.2	3											2.5	2	1.7	1.5	1.3	1	0.8	
		60 Hz	9	7.2	6	5	3.6											3	2.4	2	1.8	1.5	1.2	1		
<b>MX8G*B</b> (Ball bearing) <b>MX8G*M</b> (Metal bearing)	<b>MX8G10XB</b>	Allowable shaft torque	<b>N·m</b>	7.84	7.84	7.84	7.84	7.84											7.84	7.84	7.84	7.84	7.84	7.84	7.84	7.84
		(kgf·cm)	(80)	(80)	(80)	(80)	(80)											(80)	(80)	(80)	(80)	(80)	(80)	(80)	(80)	
Rotation direction		Same as on the motor							Opposite to that of the motor																	

#### • Sq.90 mm/40 W

Allowable shaft torque: upper line = **N·m**, lower line = **kgf·cm**

Speed reduction ratio		3	3.6	5	6	7.5	9	10	12.5	15	18	20	25											30	36	50	60	75	90	100	120	150	180
Rotating speed (r/min)	50 Hz	500	416.7	300	250	200	166.7	150	120	100	83.3	75	60											50	41.7	30	25	20	16.7	15	12.5	10	8.3
	60 Hz	600	500	360	300	240	200	180	144	120	100	90	72											60	50	36	30	24	20	18	15	12	10
Applicable gear head	<b>MX9G3B– MX9G180B</b> (Ball bearing)	50 Hz	0.66 (6.7)	0.78 (8.0)	1.08 (11)	1.27 (13)	1.57 (16)	1.86 (19)	2.25 (23)	2.74 (28)	3.23 (33)	3.92 (40)	4.41 (45)	5.29 (54)											6.37 (65)	7.94 (81)	9.80 (100)	9.80 (100)					
	<b>MX9G3M– MX9G180M</b> (Metal bearing)	60 Hz	0.55 (5.6)	0.66 (6.7)	0.90 (9.2)	1.08 (11)	1.27 (13)	1.57 (16)	1.76 (18)	2.25 (23)	2.74 (28)	3.23 (33)	3.53 (36)	4.41 (45)											5.29 (54)	6.37 (65)	8.82 (90)	9.80 (100)					
Rotation direction		Same as on the motor											Opposite to that of the motor																				

#### • When intermediate gear head is used

Applicable gear head		Speed reduction ratio	200	250	300	360	500											600	750	900	1000	1200	1500	1800		
Bearing	Intermediate gear head	Rotating speed (r/min)	50 Hz	7.5	6	5	4.2	3											2.5	2	1.7	1.5	1.3	1	0.8	
		60 Hz	9	7.2	6	5	3.6											3	2.4	2	1.8	1.5	1.2	1		
<b>MX9G*B</b> (Ball bearing) <b>MX9G*M</b> (Metal bearing)	<b>MX9G10XB</b>	Allowable shaft torque	<b>N·m</b>	9.80	9.80	9.80	9.80	9.80											9.80	9.80	9.80	9.80	9.80	9.80	9.80	9.80
		(kgf·cm)	(100)	(100)	(100)	(100)	(100)											(100)	(100)	(100)	(100)	(100)	(100)	(100)	(100)	
Rotation direction		Same as on the motor							Opposite to that of the motor																	

## 2. Installation

### Allowable shaft torque with gear head directly connected

\* The number of revolutions is calculated based on the synchronous rotating speed (1500 r/min, 1800 r/min).  
Usually, actual speed is slow by 2 to 20% the value shown in the table, depending on load condition.

#### • Sq.90 mm/60 W

Allowable shaft torque: upper line = N·m, lower line = kgf·cm

Speed reduction ratio		3	3.6	5	6	7.5	9	10	12.5	15	18	20	25													30	36	50	60	75	90	100	120	150	180	200	
Rotating speed (r/min)	50 Hz	500	416.7	300	250	200	166.7	150	120	100	83.3	75	60													50	41.7	30	25	20	16.7	15	12.5	10	8.3	7.5	
	60 Hz	600	500	360	300	240	200	180	144	120	100	90	72													60	50	36	30	24	20	18	15	12	10	9	
Applicable gear head	MZ9G3B– MZ9G200B (Ball bearing, without hinge)	50 Hz	0.98 (9.99)	1.18 (12)	1.57 (16)	1.96 (20)	2.35 (24)	2.94 (30)	3.14 (32)	3.92 (40)	4.70 (48)	5.59 (57)	6.27 (64)	7.55 (77)													9.11 (93)	11.0 (112)	15.2 (155)	17.8 (182)							19.6 (200)
	MY9G3B– MY9G200B (Ball bearing, with hinge)		60 Hz	0.78 (8.0)	0.98 (9.99)	1.37 (14)	1.57 (16)	1.96 (20)	2.35 (24)	2.65 (27)	3.33 (34)	3.92 (40)	4.70 (48)	5.29 (54)	6.47 (66)													7.55 (77)	9.11 (93)	12.6 (129)	15.2 (155)						
Rotation direction		Same as on the motor						Opposite to that of the motor						Same as on the motor																							

#### • When intermediate gear head is used

Applicable gear head		Speed reduction ratio	250	300	360	500	600													750	900	1000	1200	1500	1800	2000		
Bearing	Intermediate gear head	Rotating speed (r/min)	50 Hz	6	5	4.2	3	2.5													2	1.7	1.5	1.3	1	0.83	0.75	
			60 Hz	7.2	6	5	3.6	3													2.4	2	1.8	1.5	1.2	1	0.9	
MZ9G*B (Ball bearing, without hinge)	MZ9G10XB	Allowable shaft torque	N·m		19.6	19.6	19.6	19.6	19.6													19.6	19.6	19.6	19.6	19.6	19.6	19.6
MY9G*B (Ball bearing, with hinge)			(kgf·cm)		(200)	(200)	(200)	(200)	(200)													(200)	(200)	(200)	(200)	(200)	(200)	(200)
Rotation direction		Opposite to that of the motor		Same as on the motor																								

#### • Sq.90 mm/90 W

Allowable shaft torque: upper line = N·m, lower line = kgf·cm

Speed reduction ratio		3	3.6	5	6	7.5	9	10	12.5	15	18	20	25													30	36	50	60	75	90	100	120	150	180	200
Rotating speed (r/min)	50 Hz	500	416.7	300	250	200	166.7	150	120	100	83.3	75	60													50	41.7	30	25	20	16.7	15	12.5	10	8.3	7.5
	60 Hz	600	500	360	300	240	200	180	144	120	100	90	72													60	50	36	30	24	20	18	15	12	10	9
Applicable gear head	MZ9G3B– MZ9G200B (Ball bearing, without hinge)	50 Hz	1.37 (14)	1.67 (17)	2.25 (23)	2.74 (28)	3.43 (35)	4.12 (42)	4.51 (46)	5.68 (58)	6.76 (69)	8.04 (82)	9.02 (92)	10.9 (111)													13.0 (133)	15.7 (160)	19.6 (200)							19.6 (200)
	MY9G3B– MY9G200B (Ball bearing, with hinge)		60 Hz	1.18 (12)	1.37 (14)	1.86 (19)	2.25 (23)	2.84 (29)	3.43 (35)	3.72 (38)	4.70 (48)	5.68 (58)	6.76 (69)	7.55 (77)	9.21 (94)													10.9 (111)	13.0 (133)	18.3 (187)						
Rotation direction		Same as on the motor						Opposite to that of the motor						Same as on the motor																						

#### • When intermediate gear head is used

Applicable gear head		Speed reduction ratio	250	300	360	500	600													750	900	1000	1200	1500	1800	2000		
Bearing	Intermediate gear head	Rotating speed (r/min)	50 Hz	6	5	4.2	3	2.5													2	1.7	1.5	1.3	1	0.83	0.75	
			60 Hz	7.2	6	5	3.6	3													2.4	2	1.8	1.5	1.2	1	0.9	
MZ9G*B (Ball bearing, without hinge)	MZ9G10XB	Allowable shaft torque	N·m		19.6	19.6	19.6	19.6	19.6													19.6	19.6	19.6	19.6	19.6	19.6	19.6
MY9G*B (Ball bearing, with hinge)			(kgf·cm)		(200)	(200)	(200)	(200)	(200)													(200)	(200)	(200)	(200)	(200)	(200)	(200)
Rotation direction		Opposite to that of the motor		Same as on the motor																								

## 2. Installation

### Allowable shaft torque with High torque gear head directly connected

\* The number of revolutions is calculated based on the synchronous rotating speed (1500 r/min, 1800 r/min).  
Usually, actual speed is slow by 2 to 20% the value shown in the table, depending on load condition.

#### • Without hinge Sq.90 mm/60 W Allowable shaft torque: upper line = N·m, lower line = kgf·cm

Speed reduction ratio		50	60	75	90	100	120	150	180	200
Rotating speed (r/min)	50 Hz	30	25	20	16.7	15	12.5	10	8.3	7.5
	60 Hz	36	30	24	20	18	15	12	10	9
Applicable gear head MR9G50B– MR9G200B (Ball bearing, without hinge)	50 Hz	15.2 (155)	18.2 (186)	22.1 (225)	26.5 (270)					29.4 (300)
	60 Hz	12.7 (130)	15.2 (155)	18.6 (190)	22.1 (225)	24.6 (251)				
Rotation direction		Same as on the motor								

#### • When intermediate gear head is used

Applicable gear head		Speed reduction ratio	500	600	750	900	1000	1200	1500	1800	2000	
Bearing	Intermediate gear head	Rotating speed (r/min)	50 Hz	3	2.5	2	1.7	1.5	1.3	1	0.83	0.75
			60 Hz	3.6	3	2.4	2	1.8	1.5	1.2	1	0.9
MR9G*B (Ball bearing, without hinge)	MZ9G10XB	Allowable shaft torque	N·m	29.4	29.4	29.4	29.4	29.4	29.4	29.4	29.4	29.4
			(kgf·cm)	(300)	(300)	(300)	(300)	(300)	(300)	(300)	(300)	(300)
Rotation direction		Same as on the motor										

#### • With hinge Sq.90 mm/60 W Allowable shaft torque: upper line = N·m, lower line = kgf·cm

Speed reduction ratio		50	60	75	90	100	120	150	180	200
Rotating speed (r/min)	50 Hz	30	25	20	16.7	15	12.5	10	8.3	7.5
	60 Hz	36	30	24	20	18	15	12	10	9
Applicable gear head MP9G50B– MP9G200B (Ball bearing, with hinge)	50 Hz	15.2 (155)	18.2 (186)	22.1 (225)	26.5 (270)					29.4 (300)
	60 Hz	12.7 (130)	15.2 (155)	18.6 (190)	22.1 (225)	24.6 (251)				
Rotation direction		Same as on the motor								

#### • When intermediate gear head is used

Applicable gear head		Speed reduction ratio	500	600	750	900	1000	1200	1500	1800	2000	
Bearing	Intermediate gear head	Rotating speed (r/min)	50 Hz	3	2.5	2	1.7	1.5	1.3	1	0.83	0.75
			60 Hz	3.6	3	2.4	2	1.8	1.5	1.2	1	0.9
MP9G*B (Ball bearing, with hinge)	MZ9G10XB	Allowable shaft torque	N·m	29.4	29.4	29.4	29.4	29.4	29.4	29.4	29.4	29.4
			(kgf·cm)	(300)	(300)	(300)	(300)	(300)	(300)	(300)	(300)	(300)
Rotation direction		Same as on the motor										

#### • Without hinge Sq.90 mm/90 W Allowable shaft torque: upper line = N·m, lower line = kgf·cm

Speed reduction ratio		50	60	75	90	100	120	150	180	200	
Rotating speed (r/min)	50 Hz	30	25	20	16.7	15	12.5	10	8.3	7.5	
	60 Hz	36	30	24	20	18	15	12	10	9	
Applicable gear head MR9G50B– MR9G200B (Ball bearing, without hinge)	50 Hz	21.2 (216)	25.5 (260)					29.4 (300)			
	60 Hz	17.6 (180)	21.2 (216)	26.7 (272)					29.4 (300)		
Rotation direction		Same as on the motor									

#### • With hinge Sq.90 mm/90 W Allowable shaft torque: upper line = N·m, lower line = kgf·cm

Speed reduction ratio		50	60	75	90	100	120	150	180	200	
Rotating speed (r/min)	50 Hz	30	25	20	16.7	15	12.5	10	8.3	7.5	
	60 Hz	36	30	24	20	18	15	12	10	9	
Applicable gear head MP9G50B– MP9G200B (Ball bearing, with hinge)	50 Hz	21.2 (216)	25.5 (260)					29.4 (300)			
	60 Hz	17.6 (180)	21.2 (216)	26.7 (272)					29.4 (300)		
Rotation direction		Same as on the motor									

## 2. Installation

### Allowable shaft torque with Right-angle type gear head directly connected

\* The number of revolutions is calculated based on the synchronous rotating speed (1500 r/min, 1800 r/min).  
Usually, actual speed is slow by 2 to 20% the value shown in the table, depending on load condition.

#### • Sq.90 mm/40 W

Allowable shaft torque: upper line = **N·m**, lower line = **kgf·cm**

Speed reduction ratio		3	3.6	5	6	7.5	9	12.5	15	18	25		30	36	50	60	75	90	100	120	150	180
Rotating speed (r/min)	50 Hz	500	416.7	300	250	200	166.7	120	100	83.3	60		50	41.7	30	25	20	16.7	15	12.5	10	8.3
	60 Hz	600	500	360	300	240	200	144	120	100	72		60	50	36	30	24	20	18	15	12	10
Applicable gear head <b>MX9G3R– MX9G180R</b> (Ball bearing, without hinge)	50 Hz	0.60 (6.1)	0.72 (7.3)	0.98 (10)	1.18 (12)	1.47 (15)	1.76 (18)	2.45 (25)	2.94 (30)	3.53 (36)	5.00 (51)		6.00 (61)	7.18 (73)								9.80 (100)
	60 Hz	0.50 (5.1)	0.60 (6.1)	0.82 (8.4)	0.98 (10)	1.23 (13)	1.47 (15)	2.04 (21)	2.45 (25)	2.94 (30)	4.17 (43)		5.00 (51)	5.98 (61)	8.17 (83)							
Rotation direction		Same as on the motor																				

#### • When intermediate gear head is used

Applicable gear head		Speed reduction ratio	250	300	360	500	600		750	900	1000	1200	1500	1800	
Bearing	Intermediate gear head	Rotating speed (r/min)	50 Hz	6	5	4.2	3	2.5		2	1.7	1.5	1.3	1	0.83
		60 Hz	7.2	6	5	3.6	3		2.4	2	1.8	1.5	1.2	1	
<b>MX9G*R</b> (Ball bearing, without hinge)	<b>MX9G10XB</b>	Allowable shaft torque	<b>N·m</b>	9.80	9.80	9.80	9.80	9.80		9.80	9.80	9.80	9.80	9.80	9.80
		<b>(kgf·cm)</b>	(100)	(100)	(100)	(100)	(100)		(100)	(100)	(100)	(100)	(100)	(100)	(100)
Rotation direction		Same as on the motor													

#### • Sq.90 mm/60 W

Allowable shaft torque: upper line = **N·m**, lower line = **kgf·cm**

Speed reduction ratio		3	3.6	5	6	7.5	9	12.5	15	18	25		30	36	50	60	75	90	100	120	150	180	200
Rotating speed (r/min)	50 Hz	500	416.7	300	250	200	166.7	120	100	83.3	60		50	41.7	30	25	20	16.7	15	12.5	10	8.3	7.5
	60 Hz	600	500	360	300	240	200	144	120	100	72		60	50	36	30	24	20	18	15	12	10	9
Applicable gear head <b>MZ9G3R– MZ9G200R</b> (Ball bearing, without hinge)	50 Hz	0.90 (9.2)	1.15 (12)	1.50 (15)	1.92 (20)	2.20 (22)	2.81 (29)	3.70 (38)	4.40 (45)	5.62 (57)	7.40 (75)		8.80 (90)	11.2 (114)	14.8 (151)	18.9 (193)							19.6 (200)
	60 Hz	0.70 (7.1)	0.90 (9.2)	1.17 (12)	1.50 (15)	1.72 (18)	2.20 (22)	2.90 (30)	3.44 (35)	4.40 (45)	5.79 (59)		7.40 (75)	8.80 (90)	11.6 (118)	14.8 (151)	15.3 (156)						
Rotation direction		Same as on the motor																					

#### • When intermediate gear head is used

Applicable gear head		Speed reduction ratio	250	300	360	500	600		750	900	1000	1200	1500	1800	2000	
Bearing	Intermediate gear head	Rotating speed (r/min)	50 Hz	6	5	4.2	3	2.5		2	1.7	1.5	1.3	1	0.83	0.75
		60 Hz	7.2	6	5	3.6	3		2.4	2	1.8	1.5	1.2	1	0.9	
<b>MZ9G*R</b> (Ball bearing, without hinge)	<b>MZ9G10XB</b>	Allowable shaft torque	<b>N·m</b>	19.6	19.6	19.6	19.6	19.6		19.6	19.6	19.6	19.6	19.6	19.6	
		<b>(kgf·cm)</b>	(200)	(200)	(200)	(200)	(200)		(200)	(200)	(200)	(200)	(200)	(200)	(200)	
Rotation direction		Same as on the motor														

## 2. Installation

### Allowable shaft torque with Right-angle type gear head directly connected

\* The number of revolutions is calculated based on the synchronous rotating speed (1500 r/min, 1800 r/min).

Usually, actual speed is slow by 2 to 20% the value shown in the table, depending on load condition.

#### • Sq.90 mm/90 W

Allowable shaft torque: upper line = **N·m**, lower line = **kgf·cm**

Speed reduction ratio		3	3.6	5	6	7.5	9	12.5	15	18	25		30	36	50	60	75	90	100	120	150	180	200
Rotating speed (r/min)	50 Hz	500	416.7	300	250	200	166.7	120	100	83.3	60		50	41.7	30	25	20	16.7	15	12.5	10	8.3	7.5
	60 Hz	600	500	360	300	240	200	144	120	100	72		60	50	36	30	24	20	18	15	12	10	9
Applicable gear head <b>MZ9G3R– MZ9G200R</b> (Ball bearing, without hinge)	50 Hz	1.30 (13)	1.59 (16)	2.30 (24)	2.82 (29)	3.30 (34)	4.05 (41)	5.60 (57)	6.80 (69)	8.34 (85)	10.6 (108)		12.7 (130)	15.6 (159)	19.6 (200)								
	60 Hz	1.06 (11)	1.30 (13)	1.88 (19)	2.30 (23)	2.69 (27)	3.30 (34)	4.56 (47)	5.54 (57)	6.80 (69)	8.15 (83)		10.6 (108)	12.7 (130)	16.0 (163)	19.6 (200)							
Rotation direction		Same as on the motor																					

#### • When intermediate gear head is used

Applicable gear head		Speed reduction ratio	250	300	360	500	600		750	900	1000	1200	1500	1800	2000
Bearing	Intermediate gear head	Rotating speed (r/min)	50 Hz	6	5	4.2	3	2.5	2	1.7	1.5	1.3	1	0.83	0.75
			60 Hz	7.2	6	5	3.6	3	2.4	2	1.8	1.5	1.2	1	0.9
<b>MZ9G*R</b> (Ball bearing, without hinge)	<b>MZ9G10XB</b>	Allowable shaft torque	<b>N·m</b>	19.6	19.6	19.6	19.6	19.6	19.6	19.6	19.6	19.6	19.6	19.6	19.6
			<b>(kgf·cm)</b>	(200)	(200)	(200)	(200)	(200)	(200)	(200)	(200)	(200)	(200)	(200)	(200)
Rotation direction		Same as on the motor													

## 2. Installation

### • Allowable load of shaft

Observe the allowable loading range shown below.

	Output	Allowable overhang load (W) [N]	Allowable thrust load (F) [N]
Motor unit (round shaft)	6 W	49	7
	15 W	49	7
	25 W	108	12
	40 W	157	20
	60 W, 90 W	255	20

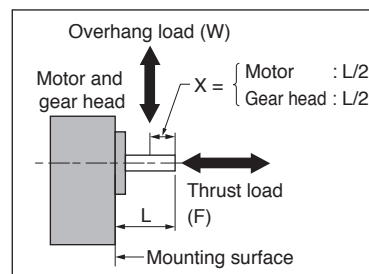

### MX\*G, MZ9G, MY9G, MR9G, MP9G type

Size (mm)	Model	Allowable overhang load (W) [N (kgf)]	Allowable thrust load (F) [N (kgf)]
Sq.60	MX6G*BA (B)	98 (10)	29 (3)
	MX6G*MA (M)	49 (5)	
Sq.70	MX7G*BA (B)	196 (20)	39 (4)
	MX7G*MA (M)	98 (10)	
Sq.80	MX8G*B	294 (30)	49 (5)
	MX8G*M	196 (20)	
Sq.90	MX9G*B	392 (40)	98 (10)
	MX9G*M	294 (30)	
	MZ9G*B	588 (60)	147 (15)
	MY9G*B		
High torque	MR9G*B	784 (80)	147 (15)
	MP9G*B		
Sq.90	MX9G*R	392 (40)	98 (10)
	Right-angle	MZ9G*R	588 (60)

### <Note>

“ \* ” in model number represents gear ratio.

### • Allowable inertia moment of load

- When using a geared motor with electromagnetic brake or a direct-current brake (optional brake unit or braking function of a speed controller), consider the moment of inertia in addition to the load torque.
- The table below shows the allowable inertia moment of load of various types of motors (equivalent motor shaft moment of inertia). If the geared motor is used under a moment of inertia exceeding these values, its life will be shortened.

### Allowable inertia moment of load and inertia moment of motor

Size (mm)	Output	Allowable inertia moment of load (kg·cm <sup>2</sup> )		Inertia moment of motor (kg·cm <sup>2</sup> ) (for reference)		
		With DC brake	Motor w/ electromagnetic brake	Induction	Reversible	W/ electromagnetic brake
60	6 W	0.125	0.080	0.163	0.173	0.201
70	15 W	0.125	0.158	0.322	0.336	0.329
80	25 W	0.138	0.178	0.578	0.600	0.603
90	40 W	0.400	0.735	1.287	1.341	1.362
	60 W	0.650	0.875	1.787	1.841	1.862
	90 W	0.650	1.000	2.211	2.265	2.353

### Life expectancy of geared motor depends on braking method

Condition	Life expectancy
DC brake is used	2000000 braking cycles
Motor w/electromagnetic brake is used	1000000 braking cycles

### • Considerations for using reversible motor

- Braking mechanism of a reversible motor cannot be used for positioning application.
- Braking mechanism of a reversible motor cannot be used for holding application.

### • Precautions on operating condition

- A variable speed motor should be used in combination with a speed controller (option).
- Motor start-stop operation must not exceed 6-cycles per minute or damage may occur.

\* Control products such as speed controllers and brake units are not listed as product requiring by China Compulsory Certification (CCC).

# 3. Wiring

- Wiring work should be performed by qualified electrician.
- Turn off power and remain off until the wiring is completed.

## Grounding (earth ground)

- Positively connect the equipment to the ground.
- Use only the grounding screw provided on the product. Tighten the screw with a torque of 1.2 to 1.5 N·m (recommended).
- For grounding a motor with seal connector, connect the connector internal ground terminal to the earth.
- Use screw, spring washer and flat washer made of stainless steel or copper alloy in the grounding circuit.
- Use round terminal as grounding terminal. Do not use U-shaped terminal.

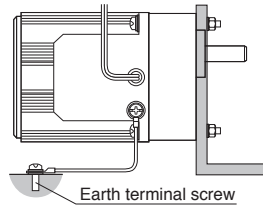

## <Precautions>

Round ground terminal and grounding leadwire, and grounding screw, spring washer and flat washer on the ground return circuit should be prepared by the customer. Earth grounding leadwire should be of size  $\phi 1.6$  mm (2 mm<sup>2</sup>) or more.

## Leadwire

Don't forcibly bend, pull or pinch motor leadwires.

## Connection

- Connections or joints of motor leadwires, power cable and capacitor should be made using soldering, connector or crimping terminal, whichever suitable, and should be covered with appropriate insulating material.
- Clamp the motor leadwires on the equipment at stable area so that the leadwires are kept stress free.
- When connecting the leadwire to the terminal block on the motor with seal connector, tighten the clamping screw with recommended torque of 0.39 to 0.49 N·m. Don't squeeze the insulation of the leadwire with the clamp. The leadwire should not have fraying conductors. Don't solder conductor of the leadwire.
- Tighten the terminal screw with recommended torque of 0.78 to 0.98 N·m.
- Tighten the screw on cap of the seal connector. The recommended torque is 3.75 to 4 N·m and size of applicable cable is  $\phi 8$  to  $\phi 12$ . Adequate tightening torque varies depending on the size and material of the cable. Find the torque value considered best suitable for the cable, but within the recommended range.
- Connect the power cable by referring to the figures shown on the next page.
- Rotation direction described in the figures refers to the direction when viewed from the motor output shaft. The direction on the gear head depends on the reduction ratio. Refer to "Allowable shaft torque" on pp.16 to 27.

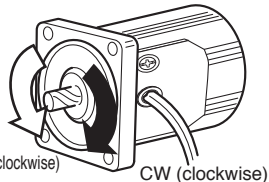
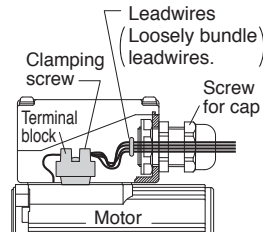

	CW (clockwise)	CCW (counterclockwise)
Sq.60 mm 4-pole Induction motor Reversible motor		Placing CW/CCW switchover switch shown left to the CCW position causes the motor to turn counterclockwise.
Sq.70 – Sq.90 mm 4-pole Induction motor Reversible motor		Placing CW/CCW switchover switch shown left to the CCW position causes the motor to turn counterclockwise.
2-pole Induction motor		Interchanging connecting point of brown and gray leads shown left causes the motor to turn counterclockwise.
2-/4-pole 3-phase motor (200/220/ 230 V)		Interchanging connecting point of 2 wires among white, gray and black leads shown left causes the motor to turn counterclockwise.
2-/4-pole 3-phase motor (380/400 V)		Interchanging connecting point of 2 wires among white, gray and black leads shown left causes the motor to turn counterclockwise.
Sq.60 mm 4-pole Electromagnetic brake type single-phase motor		Placing CW/CCW switchover switch shown left to the CCW position causes the motor to turn counterclockwise.



# 3. Wiring

	CW (clockwise)	CCW (counterclockwise)
Sq.70 – Sq.90 mm 4-pole Electromagnetic brake type single-phase motor		Placing CW/CCW switchover switch shown left to the CCW position causes the motor to turn counterclockwise.
4-pole Electromagnetic brake type three-phase motor (200/220/ 230 V)		Interchanging connecting point of 2 wires among white, gray and black leads shown left causes the motor to turn counterclockwise.
4-pole Electromagnetic brake type three-phase motor (380/400 V)		Interchanging connecting point of 2 wires among white, gray and black leads shown left causes the motor to turn counterclockwise.

\* Color in the figures above indicates the color of lead wire and a symbol in ( ) indicates the terminal.  
 \* For the wiring procedure for the variable speed model, refer to the speed controller instruction manual.

### <Note>

Motors of Sq.70, Sq.80 and Sq.90 mm are provided with a thermal protector as an over-temperature protecting device.

- The thermal protector (250 VAC, 3 A) is connected to blue leads.
- The thermal protector is fixed to stator winding of the motor.
- The thermal protector is an automatic reset type. To prevent hazardous unintentional restart, it must be wired as shown in the figure above.  
(Connect a spark killer to the electromagnetic contactor.)  
Do not connect the thermal protector directly to the power source. Instead, connect it to the source through the switch SW A and SW B and relay (Ry).
- Operating temperature: 130 ±5 °C; recovery temperature: 90 ±15 °C; on-off durability: 5000 cycles.
- Automatic reset protector, when left active (under motor locked or overloading condition), cycles power on and off. If the cycles exceeds 5000 cycles, it will fail to work correctly, causing heat damage to the motor.
- When the protector operates, immediately turn off the motor and remove the cause of failure. Install an overcurrent protector and ground-fault circuit interrupter to the power supply.

### <Precautions>

- The rated power supply voltage of the thermal protector is 250 VAC. When using a motor operating from 380/400 VAC 3-phase supply, provide a means to feed 100 to 250 VAC: by either 1) using a step-down transformer or 2) connecting it to across neutral R and N.
- The customer is responsible to prepare and install switches (symbol SWA, SWB, etc., in the figure), relay (symbol Ry) or molded case circuit breaker (symbol MCCB) as necessary.
- To protect the contacts of switches (symbol SWA, SWB, etc., in the figure) and relay (symbol Ry), connect spark killer across them. Optional protector DV0P008A is available through our sales distributors. Note that this protector is not for motors rated at 380/400 VAC. If you want to use a spark killer capable of protecting at 380/400 VAC, prepare a protector rated at 450 VAC or higher (resistance: 10 to 200 Ω, 1/4 W or more, capacitance: 0.1 to 0.33 μ F).

### Connecting capacitor (for single-phase only)

Capacitor has 4 terminals. The terminals A and B, and terminals C and D are internally connected together as shown in the figures below (these terminals have no identification marks such as A, B, C, D). This means that the capacitor has 2 electrical terminals. When using a crimp contact, it is recommended to use Faston 187 series terminal. While the motor is operating, a voltage about 2 times the voltage of the supplied power is applied across the capacitor terminals. For the purpose of safety, use a capacitor cap as shown below. The capacitor cap should have a means to prevent it and leadwires from becoming loose, as shown below: e.g. tie strap.

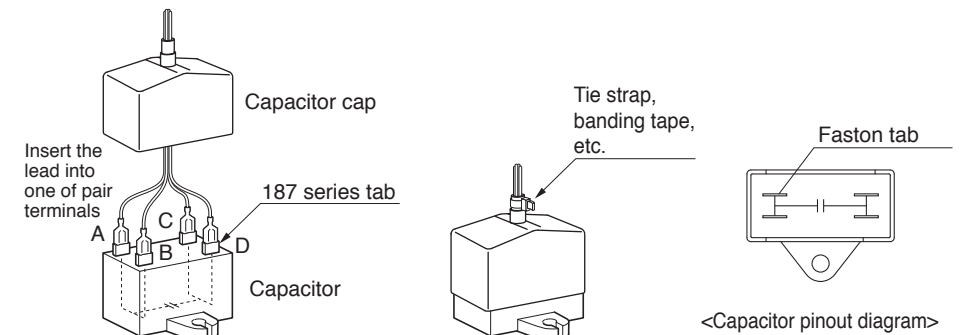

\* Capacitor terminals don't have designation.

### <Important>

**Don't connect 2 or more leads to a single terminal.**

## 4. Operation

### Prepare for operation

- **Verify the following:**
  - Power is correctly connected
  - Ground circuit is connected to the earth return
  - Fuses and molded case circuit breaker are at the rated capacity
  - Terminals of capacitor are positively isolated with a suitable material e.g. the capacitor cap.
  - No loosen joints, connections, fasteners
  - No sign of leakage of oil, grease, etc.

### Trial run

- **Following the successive checking, start the trial run:**
  - (1) Without connecting load, operate the system with the motor and gear head. Check direction and speed of turning, and for unusual vibration and noise. Then, incorporate the unit into the application system.

 <b>Do</b>	<b>Verify turning direction</b>	Wrong model or wrong wiring will cause personal injury.
--	---------------------------------	---
  - (2) Turn on power. Verify smooth running of the motor and no usual sound from bearing and gear head.

### During operation

- **Checking the load**
  - Check the amount of the current and adjust the load so that the magnitude of the conducted current does not exceed the nameplate rating.
  - When the reduction ratio of the installed gear head is 1/50 or more, the torque may exceed the allowable shaft torque of the gear head even if the current flow rate is below the rated current. Check if the torque is below the allowable shaft torque and adjust the load as necessary.
- **Check the motor temperature rise**
  - The motor temperature reaches a stable value by 2 or 3 hours (by 30 minutes when reversible motor or single-phase electromagnetic brake motor) after startup. Take into consideration the time rating.
  - Keep the frame surface temperature at 90 °C or below during operation at ambient temperature 40 °C.

### Upon occurrence of power interruption

- **Turn off power switch**

If the power switch is left on, the machine will operate disorderly as power is fed again, causing possible personal injury, damage to property. Or it cannot start due to too heavy load, causing heat damage to the motor.

### During operation

- **Do not touch your body or hand to the unit to avoid burn injury.**
- **If a failure occurs, immediately stop the operation.**  
**Check the system and consult your local dealer.**

### Other precautions

- **Checking starting voltage**

Using a voltmeter and a variable transformer, measure the starting voltage of the assembly incorporating the geared motor. Make sure that the voltage is lower than the value shown below.

  - (1) Reversible motor: 70% the rated voltage
  - (2) Induction motor: 80% the rated voltage
  - Variable voltage causes starting error.
  - Holding torque of the reversible motor varies depending on products, aged deterioration and temperature, which cause starting error.

## 5. Inspection and maintenance

Periodically perform check and maintenance to assure safe and reliable operation.

### Practical considerations for maintenance

- To secure safety during maintenance operation, turning off/on of power supply must be done by the personnel who is responsible for the current maintenance work.
- Do not touch the motor while it is still running or immediately after it stops. (Motor is hot.)
- Before starting the megger testing of the motor (to measure the insulation resistance), completely disconnect it from associated devices and components. Otherwise, the megger tester will damage the devices under test.

### Daily check

- Perform the daily check to prevent potential problems.
- Perform appropriate corrective actions upon finding any failure or defective.

Item to be checked	Checking method	Description
Change in voltage	Voltmeter	Rated voltage $\pm 2$ to 3%. Although the specification assures normal operation within $\pm 10\%$ deviation, the motor performance and life are not secured.
Load current	Ammeter	As indicated on the nameplate
Ambient temperature	Thermometer	$-10$ °C to $+40$ °C
Temperature rise	Thermometer	90 °C or below on frame surface (ambient temperature 40 °C)
Noise	Auditory perception	No increase in abnormal sound or noise level
Vibration	Vibrometer/feeling	No abnormal vibration
Deposition of powder dust	Visual	Flow or cooling air is not disturbed by dust and powder.
Oil leakage	Visual	No oil or grease from joint to gear head or from output shaft
Insulation resistance	Insulating-resistance tester	Connect the 500 V megger across motor lead and earth terminal. The reading should be 50 M $\Omega$ or more.
Grease leakage	Visual	Check exterior and peripheral of motor and gear head for coat of grease or oil. If the leakage will affect the application, use cover as necessary.
Foundation bolt	Torque wrench	Check bolts for loosening and retighten as necessary.

### Standard life expectancy

- For typical life expectancy, refer to p. 15 and p. 29 (section 2. Installation).

### Guideline for replacement

- No reference established since components and parts should be replaced based on operating condition and method. However, defective or malfunctioning parts should be replaced or repaired.

 DON'T	<b>Consult us when it is necessary to overhaul the assembly.</b>	Incorrect disassembly will cause malfunction.
--	--	---

## 6. Troubleshooting

Symptom	Possible cause	Corrective action
Motor does not run.	Wrong wiring	Correct the wiring.
	Applied voltage is out of specification.	Apply correct voltage.
	Not specified capacitor or the capacitor is not correctly connected.	Check the capacitor against the nameplate. Connect the specified capacitor according to the wiring diagram.
	Load is too large.	Reduce the load, or use higher output motor.
Motor runs in reverse direction.	Wrong wiring	Correct the wiring.
	Wiring does not match the reduction ratio of the gear head.	Correct the wiring to match the rotating direction of the output shaft.
	The capacitor is not connected as specified in the wiring diagram.	Correctly connect the capacitor.
	Viewing the motor from wrong side.	When checking the direction of the shaft, view the motor from its output shaft side.
Motor temperature is too high.	The voltage of the supply is out of spec.	Apply the specified voltage.
	The capacitance of the capacitor is out of spec.	Use a capacitor of the specified capacitance.
	Frame surface temperature of the motor depends on the ambient temperature, loading and start/stop cycles. If the temperature is over 90 °C, the motor may become defective.	If the temperature on the frame surface exceeds 90 °C, use a higher output motor. Otherwise, reduce the load.

## 7. Specification

### General specification

Item		Specification		
Time rating		Induction motor	Reversible motor	3-phase motor
		Continuous	30 minutes	Continuous
Basic specification	Supply voltage permissible variable range	$\pm 10\%$ (nameplate rating)*		
	Power supply frequency	50/60 Hz (nameplate rating)		
	Ambient conditions	See section 2. Installation (p. 9).		
Cooling method		Natural air-cooling (variable speed 90 W: forced cooling)		
Heat resistance class		130 (B)		

\*  $\pm 10\%$  does not mean level of continuously applicable voltage.

# 8. Compatible with international standards

## EC directives

EC directives cover all general consumer electronics having specific functions and to be directly delivered to European Union (EU).

These electronic products must meet safety standards commonly applicable to all EU member nations, and must bear CE marking.

Our products are compatible with standards referenced by Low Voltage Directive so that the machines and devices incorporating our products will meet requirements of EC directives.

## Compatible standards

	Standard	Accreditation organization	File No.
UL	UL1004-1 Standard for motors	UL	E 305791 (6 W) E 171872 (single-phase 15 to 150 W) E 166557 (3-phase 25 to 150 W)
	UL1004-2 Standard for impedance protected motors (6 W)		
	UL1004-3 Standard for thermally protected motors (single-phase 15 to 150 W)		
CSA (c-UL)	C22.2 No.100 Standard for motors	UL	E 305791 (6 W) E 171872 (single-phase 15 to 150 W) E 166557 (3-phase 25 to 150 W)
	C22.2 No.77 Standard for inherent overheating protection of motors		
CE	EN60034-1 Standard for motors	TÜV SÜD	Please confirm the validation number on our homepage when it is necessary.
	EN60034-5 Standard for protection method of motors		
	EN60034-11 Standard for overheating protection of motors		
CCC	GB12350 Standard for safety of low power motors	CQC	Please confirm the validation number on our homepage when it is necessary.

Homepage  
[industrial.panasonic.com/ac/e/](http://industrial.panasonic.com/ac/e/)

## Peripherals layout practices

<b>Power supply</b>	Voltage, frequency: Nameplate ratings Size of conductor must meet EN60204-1.
<b>Molded case circuit breaker/ fuse</b>	Connect between power source and the motor: IEC approved and UL approved molded case circuit breaker or UL approved fuse.
<b>Ground</b>	To prevent electric shock, connect the ground terminal (with screw) to the protective earth (PE). Do not connect two or more protective grounding conductors to a single PE.

## Wiring peripherals

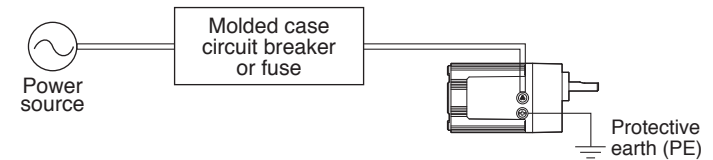

## Conformance to UL and CSA

<ul style="list-style-type: none"> <li>• UL1004-1</li> <li>• CSA C22.2 No.100</li> </ul>	All products conform to these standards.
<ul style="list-style-type: none"> <li>• UL1004-2</li> <li>• CSA C22.2 No.77</li> </ul>	6 W motors conform to these standards.
<ul style="list-style-type: none"> <li>• UL1004-3</li> <li>• CSA C22.2 No.77</li> </ul>	<ul style="list-style-type: none"> <li>• Single-phase 2-pole motors conform to these standards.</li> <li>• These standards do not apply to single-phase 15 to 90 W 4-pole motors wired as shown in wiring diagrams on pp. 31 to 32.</li> </ul> <p>For example, when the thermal protector is connected in series between power line and motor white terminal (U1), this circuit becomes compatible.</p> <ul style="list-style-type: none"> <li>• These standards do not apply to 3-phase motors.</li> </ul>

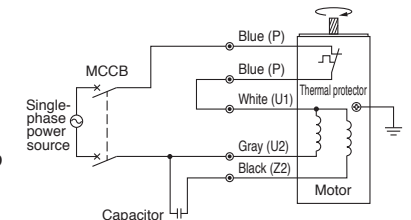

# After-Sale Service (Repair)

## Repair

Consult to a dealer from whom you have purchased the product for details of repair. When the product is incorporated to the machine or equipment you have purchased, consult to the manufacturer or the dealer of the machine or equipment.

## Cautions for Proper Use

- This product is intended to be used with a general industrial product, but not designed or manufactured to be used in a machine or system that may cause personal death when it is failed.
- Install a safety equipments or apparatus in your application, when a serious accident or loss of property is expected due to the failure of this product.
- Consult us if the application of this product is under such special conditions and environments as nuclear energy control, aerospace, transportation, medical equipment, various safety equipments or equipments which require a lesser air contamination.
- We have been making the best effort to ensure the highest quality of the products, however, application of exceptionally larger external noise disturbance and static electricity, or failure in input power, wiring and components may result in unexpected action. It is highly recommended that you make a fail-safe design and secure the safety in the operative range.
- If the motor shaft is not electrically grounded, it may cause an electrolytic corrosion to the bearing, depending on the condition of the machine and its mounting environment, and may result in the bearing noise. Checking and verification by customer is required.
- Failure of this product depending on its content, may generate smoke of about one cigarette. Take this into consideration when the application of the machine is clean room related.
- Please be careful when using in an environment with high concentrations of sulphur or sulphuric gases, as sulphuration can lead to disconnection from the chip resistor or a poor contact connection.
- Take care to avoid inputting a supply voltage which significantly exceeds the rated range to the power supply of this product. Failure to heed this caution may result in damage to the internal parts, causing smoking and/or a fire and other trouble.

## Technical information

Technical information of this product (Instruction Manual, CAD data) can be downloaded from the following web site.  
[industrial.panasonic.com/ac/e/](http://industrial.panasonic.com/ac/e/)

MEMO (Fill in the blanks for reference in case of inquiry or repair.)

<b>Date of purchase</b>		<b>Model No.</b>	
<b>Dealer</b>			
	Tel: (    )                      -		

## Panasonic Corporation

7-1-1 Morofuku, Daito, Osaka, 574-0044, Japan Phone : +81-72-871-1212

---

# MEMO

A series of horizontal dashed lines for writing.