

3-phase Motor

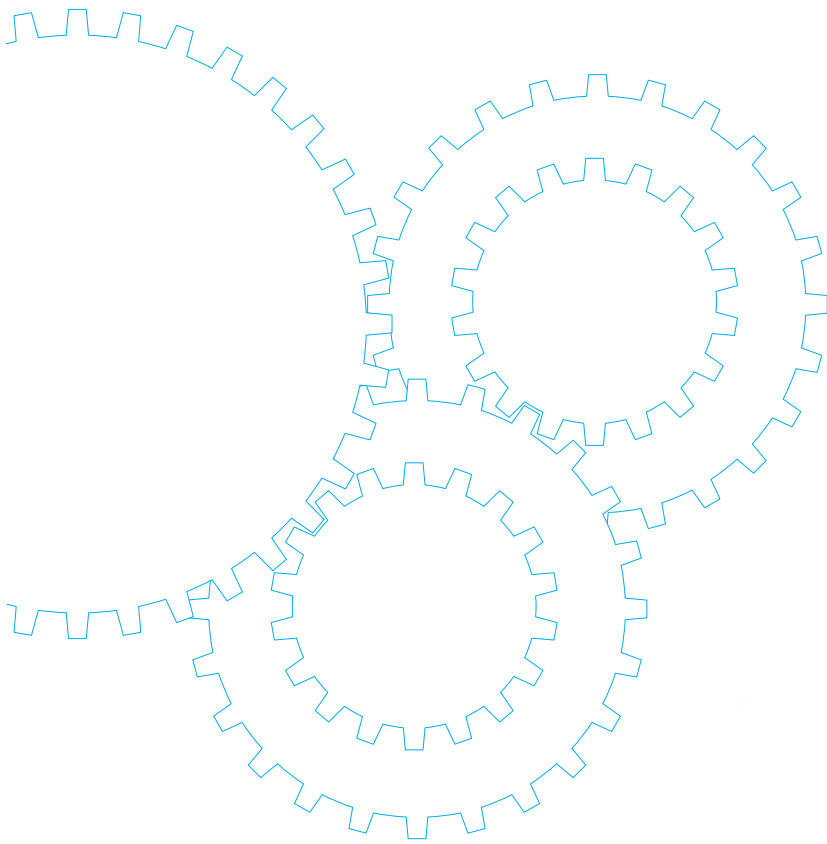

Contents

- Motor Overview B-126
- Model list B-128
- Product information for each model B-130
- Gear head combination dimensions B-162
- Round shaft motor dimensions B-164

This product is for industrial equipment. Don't use this product at general household.

Features

- The 3-phase motor is an induction motor for 3-phase power.
- Continuous time rating
- The motor with national specifications is of heatproof class 120 (E); the motor with specifications compliant with overseas standards is of heatproof class 130 (B).

Construction

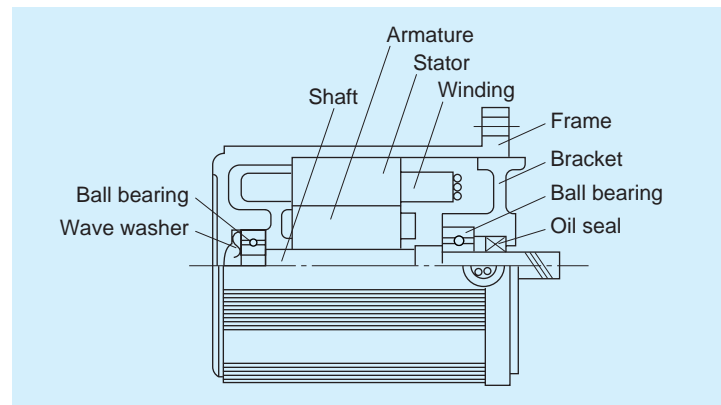

Characteristics

Speed-torque characteristics

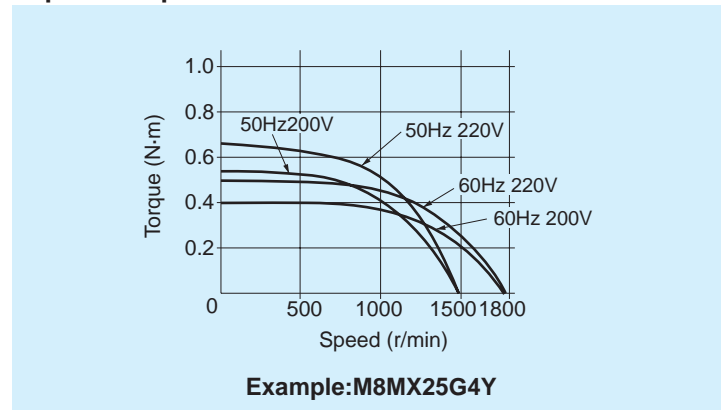

System configuration diagram

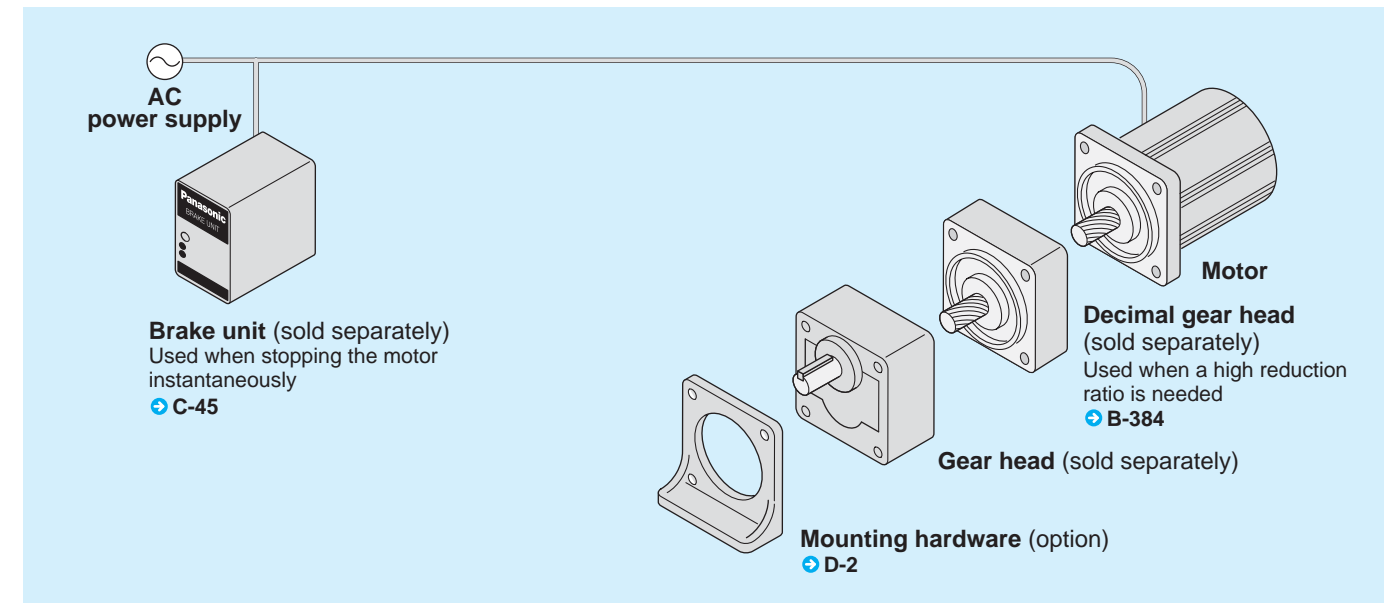

Coding system

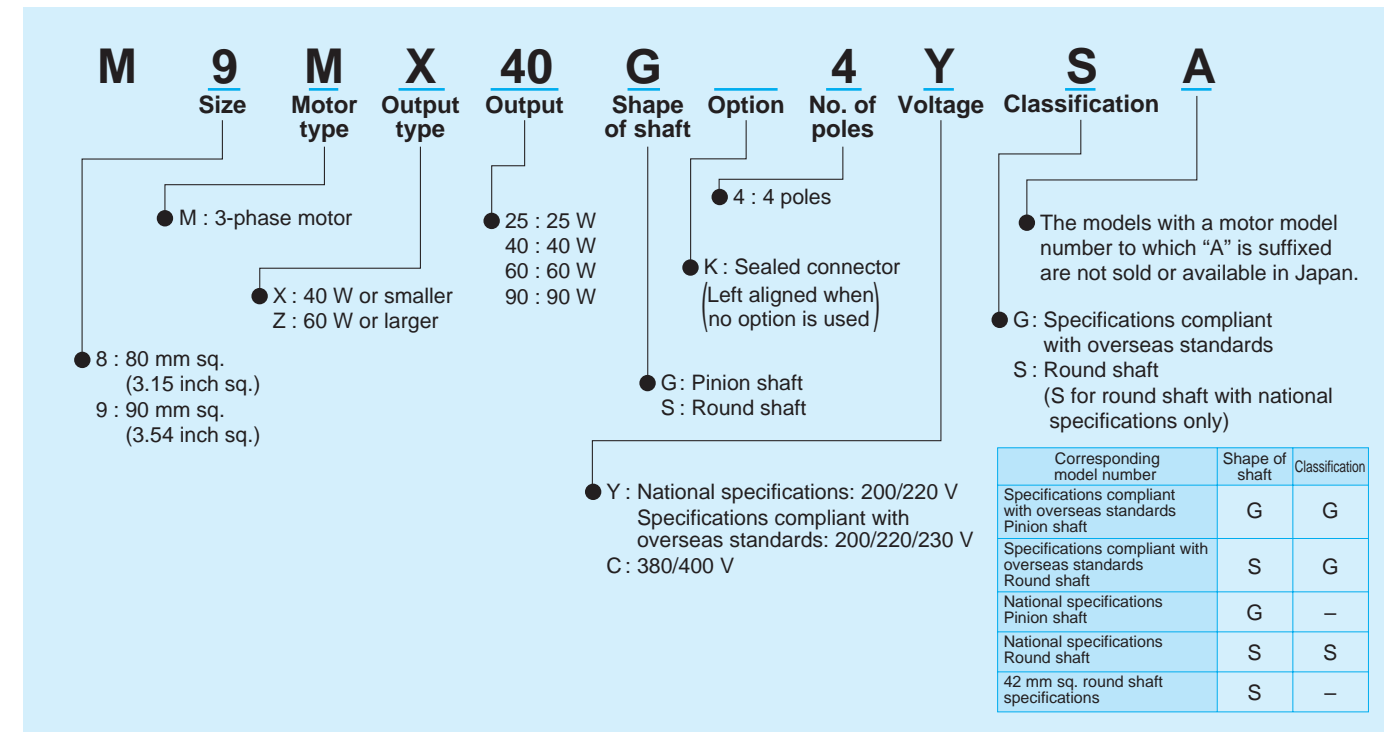

Fit tolerance

Fit tolerance symbol is used in the outside dimension diagram of motor and gear head. For further information, see "Fit tolerance" on page A-33.

Model list of 3-phase motor

Pinion shaft motor

Applicable gear head

★ Motor compliant with overseas standards c  CE 



Size	Output (W)	Leadwire type			Sealed connector type		
		Model number	Specifications	Page	Model number	Specifications	Page
80 mm sq. (3.15 inch sq.)	25	M8MX25G4Y	200/220V	B-130	M8MX25GK4Y	200/220V	B-146
		M8MX25G4YG(A)	200/220/230V ★	B-132	M8MX25GK4YG(A)	200/220/230V ★	B-148
					M8MX25GK4CG(A)	380/400V ★	B-148
90 mm sq. (3.54 inch sq.)	40	M9MX40G4Y	200/220V	B-134	M9MX40GK4Y	200/220V	B-150
		M9MX40G4YG(A)	200/220/230V ★	B-136	M9MX40GK4YG(A)	200/220/230V ★	B-152
					M9MX40GK4CG(A)	380/400V ★	B-152
	60	M9MZ60G4Y	200/220V	B-138	M9MZ60GK4Y	200/220V	B-154
		M9MZ60G4YG(A)	200/220/230V ★	B-140	M9MZ60GK4YG(A)	200/220/230V ★	B-156
					M9MZ60GK4CG(A)	380/400V ★	B-156
	90	M9MZ90G4Y	200/220V	B-142	M9MZ90GK4Y	200/220V	B-158
		M9MZ90G4YG(A)	200/220/230V ★	B-144	M9MZ90GK4YG(A)	200/220/230V ★	B-160
					M9MZ90GK4CG(A)	380/400V ★	B-160

 Hinge attached

Standard gear head		High torque gear head	Right-angle gear head	Gear head -Inch (U.S.A.)	Decimal gear head
Ball bearing	metal bearing				
MX8G□B	MX8G□M	—	—	MX9G□BU	MX8G10XB
MX9G□B	MX9G□M	—	MX9G□R	MX9G□BU	MX9G10XB
MZ9G□B	—	MR9G□B	MZ9G□R	MZ9G□BU	MZ9G10XB
MY9G□B	—	MP9G□B			

* Refer to page B-444 for dimensions and permissible torque of high torque gear head.
 Refer to page B-446 for dimensions and permissible torque of right-angle gear head.
 Refer to page B-451 for dimensions and permissible torque of gear head -Inch (U.S.A.).
 Refer to page B-448 for dimensions of decimal gear head.

Round shaft motor

★ Motor compliant with overseas standards c  CE 
 Ⓢ Electrical Appliance and Material Safety Law

Size	Output (W)	Leadwire type		Sealed connector type	
		Model number	Specifications	Model number	Specifications
80 mm sq. (3.15 inch sq.)	25	M8MX25S4YS	200/220V	M8MX25SK4YS	200/220V Ⓢ
		M8MX25S4YG(A)	200/220/230V ★	M8MX25SK4YG(A)	200/220/230V ★ Ⓢ
				M8MX25SK4CG(A)	380/400V ★
90 mm sq. (3.54 inch sq.)	40	M9MX40S4YS	200/220V	M9MX40SK4YS	200/220V Ⓢ
		M9MX40S4YG(A)	200/220/230V ★	M9MX40SK4YG(A)	200/220/230V ★ Ⓢ
				M9MX40SK4CG(A)	380/400V ★
	60	M9MZ60S4YS	200/220V	M9MZ60SK4YS	200/220V Ⓢ
		M9MZ60S4YG(A)	200/220/230V ★	M9MZ60SK4YG(A)	200/220/230V ★ Ⓢ
				M9MZ60SK4CG(A)	380/400V ★
	90	M9MZ90S4YS	200/220V	M9MZ90SK4YS	200/220V Ⓢ
		M9MZ90S4YG(A)	200/220/230V ★	M9MZ90SK4YG(A)	200/220/230V ★ Ⓢ
				M9MZ90SK4CG(A)	380/400V ★

* The specifications and wire connections of the round shaft motor are the same as those of the pinion shaft motor.
 Dimensional outline drawing → Page B-164.

<Notice>

380V/400V 3-phase round shaft motors with a sealed connector are not covered by the Electrical Appliance and Material Safety Law.

Specifications

Size	Motor model No.	Number of pole (P)	Output (W)	Voltage (V)	Frequency (Hz)	Rating (min)	Rating				Starting current (A)	Starting torque N-m (oz-in)
							Input (W)	Current (A)	Speed (r/min)	Torque N-m (oz-in)		
80 mm sq.	M8MX25G4Y	4	25	200	50	Cont.	50	0.25	1350	0.18 (25.5)	0.62	0.54 (76.5)
							47	0.22	1625	0.15 (21.2)	0.58	0.40 (56.6)
				220	50	Cont.	54	0.27	1375	0.18 (25.5)	0.67	0.66 (93.5)
							49	0.23	1650	0.15 (21.2)	0.64	0.50 (70.8)

The specifications and wire connections of the round shaft motor are the same as those of the pinion shaft type. For the dimensional outline drawing, refer to page B-164.

Permissible torque at output shaft of gear head

* The speed shown below is a calculated value based on the synchronous rotational speed. Depending on the load, the speed is less than the indicated value by 2 to 20%.

Unit of permissible torque: upper (N·m) / lower (lb·in)

Reduction ratio	Unit of permissible torque: upper (N·m) / lower (lb·in)																							
	3	3.6	5	6	7.5	9	10	12.5	15	18	20	25	30	36	50	60	75	90	100	120	150	180		
Speed (r/min)	50Hz	500	416.7	300	250	200	166.7	150	120	100	83.3	75	60	50	41.7	30	25	20	16.7	15	12.5	10	8.3	
	60Hz	600	500	360	300	240	200	180	144	120	100	90	72	60	50	36	30	24	20	18	15	12	10	
Applicable gear head	MX8G3B to MX8G180B (ball bearing)	50Hz	0.39 (3.45)	0.47 (4.16)	0.66 (5.84)	0.78 (6.90)	0.98 (8.67)	1.18 (10.4)	1.27 (11.2)	1.57 (13.9)	1.96 (17.3)	2.35 (20.8)	2.55 (22.6)	3.14 (27.8)	3.82 (33.8)	4.61 (40.8)	6.37 (56.4)	7.64 (67.6)						7.84 (69.4)
		60Hz	0.32 (2.83)	0.39 (3.45)	0.55 (4.87)	0.66 (5.84)	0.81 (7.17)	0.98 (8.67)	1.08 (9.56)	1.27 (11.2)	1.57 (13.9)	1.96 (17.3)	2.06 (18.2)	2.65 (23.5)	3.14 (27.8)	3.82 (33.8)	5.29 (46.8)	6.37 (56.4)						7.84 (69.4)
Rotational direction		Same as motor rotational direction											Reverse to motor rotational direction											

Permissible torque at output shaft of gear head using decimal gear head

Applicable gear head		Reduction ratio	Reduction ratio														
Bearing	Decimal gear head		Speed (r/min)	200	250	300	360	500	600	750	900	1000	1200	1500	1800		
		MX8G□B (ball bearing) MX8G□M (metal bearing)		MX8G10XB	50Hz	7.5	6	5	4.2	3	2.5	2	1.7	1.5	1.3	1	0.8
60Hz	9		7.2		6	5	3.6	3	2.4	2	1.8	1.5	1.2	1			
		Permissible torque	N-m (lb-in)	7.84 (69.4)	7.84 (69.4)	7.84 (69.4)	7.84 (69.4)	7.84 (69.4)	7.84 (69.4)	7.84 (69.4)	7.84 (69.4)	7.84 (69.4)	7.84 (69.4)	7.84 (69.4)			
		Rotational direction	Same as motor rotational direction			Reverse to motor rotational direction											

Connection diagram

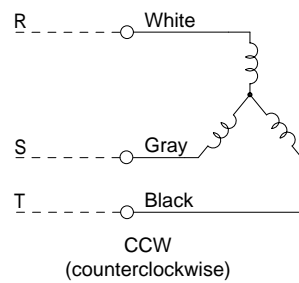

Change any two lead wires of R, S and T for CW rotation.

Speed-torque characteristics

M8MX25G4Y

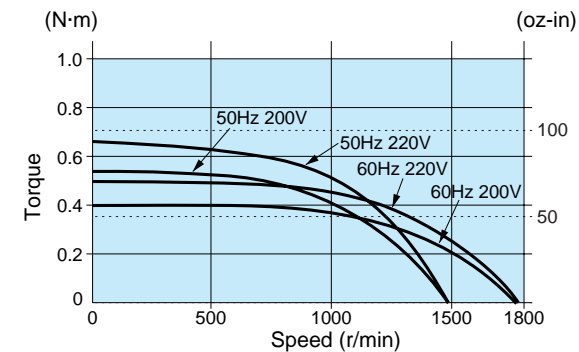

Motor (dimensions)

M8MX25G4Y 4P 25 W 200 V / 220 V

Scale: 1/3, Unit: mm (inch)

Mass	Helical gear	Module	Number of teeth
1.5 kg 3.31 lb		0.5	9

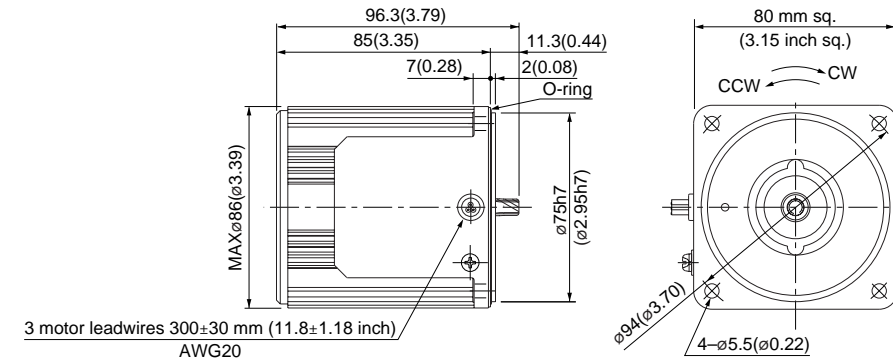

Connection diagram

Gear head (dimensions)

Scale: 1/3, Unit: mm (inch)

MX8G□B (ball bearing) / MX8G□M (metal bearing) Mass 0.6 kg (1.32 lb)

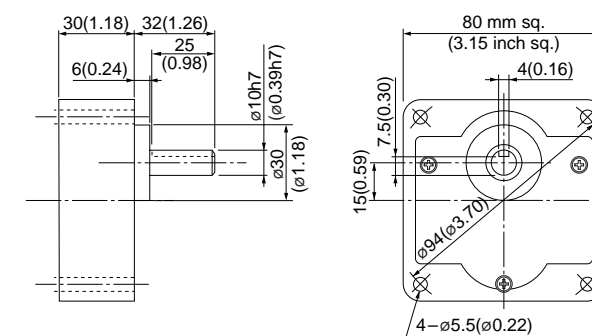

Key and keyway (dimensions) [attachment]

MX8G□B(M)

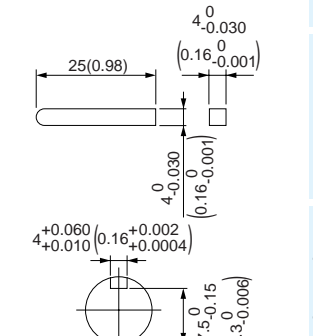

* Please read your User's manual carefully so that you will understand the operation and safety precautions before attempting to operate the system.

(Note) Because the dimensions may be subject to change, also check the determinate dimensions if the gear head is to be used for design.

Specifications

Size	Motor model No.	Number of pole (P)	Output (W)	Voltage (V)	Frequency (Hz)	Rating (min)	Rating				Starting current (A)	Starting torque N-m (oz-in)
							Input (W)	Current (A)	Speed (r/min)	Torque N-m (oz-in)		
80 mm Sq.	M8MX25G4YG M8MX25G4YGA	4	25	200	50	Cont.	50	0.25	1350	0.18 (25.5)	0.62	0.54 (76.5)
							47	0.22	1625	0.15 (21.2)	0.58	0.40 (56.6)
							49	0.23	1650	0.14 (19.8)	0.64	0.50 (70.8)
							50	0.24	1675	0.14 (19.8)	0.65	0.54 (76.5)

• The specifications and wire connections of the round shaft motor are the same as those of the pinion shaft type. For the dimensional outline drawing, refer to page B-164.
 • The models with a motor model number to which "A" is suffixed are not sold or available in Japan.

Permissible torque at output shaft of gear head

* The speed shown below is a calculated value based on the synchronous rotational speed. Depending on the load, the speed is less than the indicated value by 2 to 20%.

Unit of permissible torque: upper (N·m) / lower (lb·in)

Reduction ratio	Unit of permissible torque: upper (N·m) / lower (lb·in)																						
	3	3.6	5	6	7.5	9	10	12.5	15	18	20	25	30	36	50	60	75	90	100	120	150	180	
Speed (r/min)																							
50Hz	500	416.7	300	250	200	166.7	150	120	100	83.3	75	60	50	41.7	30	25	20	16.7	15	12.5	10	8.3	
60Hz	600	500	360	300	240	200	180	144	120	100	90	72	60	50	36	30	24	20	18	15	12	10	
Applicable gear head	MX8G3B to MX8G180B (ball bearing)	50Hz	0.39 (3.45)	0.47 (4.16)	0.66 (5.84)	0.78 (6.90)	0.98 (8.67)	1.18 (10.4)	1.27 (11.2)	1.57 (13.9)	1.96 (17.3)	2.35 (20.8)	2.55 (22.6)	3.14 (27.8)	3.82 (33.8)	4.61 (40.8)	6.37 (56.4)	7.64 (67.6)					7.84 (69.4)
		60Hz	0.32 (2.83)	0.39 (3.45)	0.55 (4.87)	0.66 (5.84)	0.81 (7.17)	0.98 (8.67)	1.08 (9.56)	1.27 (11.2)	1.57 (13.9)	1.96 (17.3)	2.06 (18.2)	2.65 (23.5)	3.14 (27.8)	3.82 (33.8)	5.29 (46.8)	6.37 (56.4)					7.84 (69.4)
Rotational direction	Same as motor rotational direction											Reverse to motor rotational direction											

Permissible torque at output shaft of gear head using decimal gear head

Applicable gear head		Reduction ratio	Reduction ratio														
Bearing	Decimal gear head		Speed (r/min)	200	250	300	360	500	600	750	900	1000	1200	1500	1800		
		MX8G□B (ball bearing) MX8G□M (metal bearing)		MX8G10XB	50Hz	7.5	6	5	4.2	3	2.5	2	1.7	1.5	1.3	1	0.8
60Hz	9		7.2		6	5	3.6	3	2.4	2	1.8	1.5	1.2	1			
		Permissible torque	N-m (lb-in)	7.84 (69.4)	7.84 (69.4)	7.84 (69.4)	7.84 (69.4)	7.84 (69.4)	7.84 (69.4)	7.84 (69.4)	7.84 (69.4)	7.84 (69.4)	7.84 (69.4)	7.84 (69.4)			
		Rotational direction	Same as motor rotational direction / Reverse to motor rotational direction														

Connection diagram

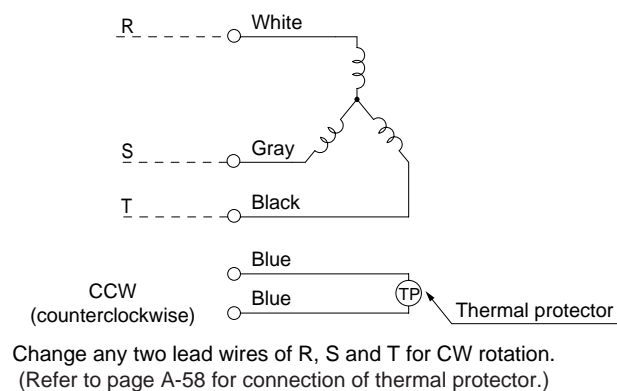

Speed-torque characteristics

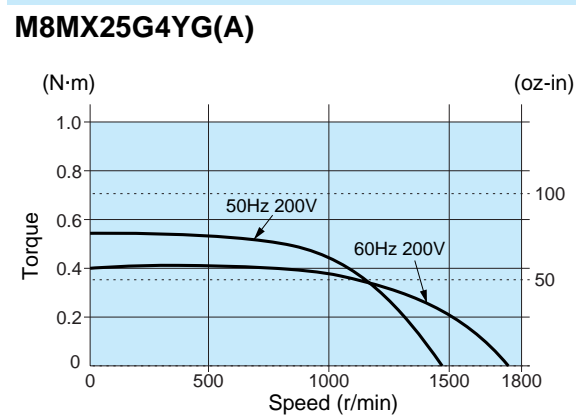

Motor (dimensions)

M8MX25G4YG(A) 4P 25 W 200 V / 220 V / 230 V

Scale: 1/3, Unit: mm (inch)

Mass **1.5 kg**
3.31 lb
 Helical gear **Module 0.5**
 Number of teeth **9**

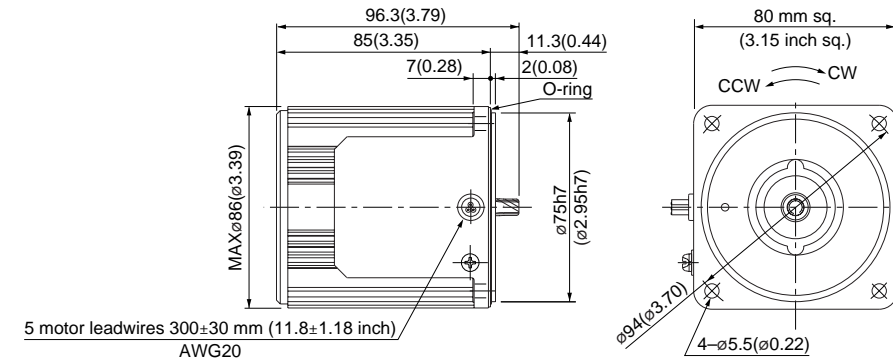

Gear head (dimensions)

Scale: 1/3, Unit: mm (inch)

MX8G□B (ball bearing) / **MX8G□M** (metal bearing) Mass 0.6 kg (1.32 lb)

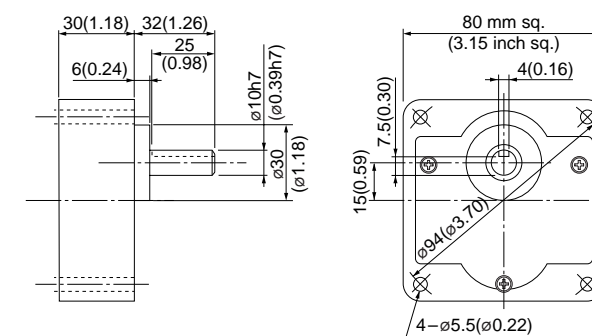

Key and keyway (dimensions) [attachment]

MX8G□B(M)

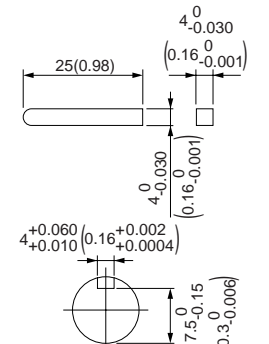

* Please read your User's manual carefully so that you will understand the operation and safety precautions before attempting to operate the system.

(Note) Because the dimensions may be subject to change, also check the determinate dimensions if the gear head is to be used for design.

Induction motor
 Reversible motor
 3-phase motor
 Electromagnetic brake motor
 Variable speed induction motor
 Variable speed reversible motor
 Variable speed electronic brake single-phase motor
 Variable speed unit motor
 C&B motor
 2-pole round shaft motor
 Gear head
 Gear head -inch (U.S.A.)

Specifications

Size	Motor model No.	Number of pole (P)	Output (W)	Voltage (V)	Frequency (Hz)	Rating (min)	Rating				Starting current (A)	Starting torque N-m (oz-in)
							Input (W)	Current (A)	Speed (r/min)	Torque N-m (oz-in)		
90 mm sq.	M9MX40G4Y	4	40	200	50	Cont.	69	0.31	1350	0.28 (39.7)	0.90	0.72 (102)
					60		68	0.29	1625	0.24 (34.0)	0.82	0.51 (72.2)
				220	50	Cont.	70	0.32	1375	0.27 (38.2)	1.0	0.88 (125)
					60		66	0.28	1675	0.23 (32.6)	0.91	0.63 (89.2)

* The specifications and wire connections of the round shaft motor are the same as those of the pinion shaft type. For the dimensional outline drawing, refer to page B-164.

Permissible torque at output shaft of gear head

* The speed shown below is a calculated value based on the synchronous rotational speed. Depending on the load, the speed is less than the indicated value by 2 to 20%.

Unit of permissible torque: upper (N·m) / lower (lb-in)

Reduction ratio	Speed (r/min)																						
	3	3.6	5	6	7.5	9	10	12.5	15	18	20	25	30	36	50	60	75	90	100	120	150	180	
Speed (r/min)	50Hz	500	416.7	300	250	200	166.7	150	120	100	83.3	75	60	50	41.7	30	25	20	16.7	15	12.5	10	8.3
	60Hz	600	500	360	300	240	200	180	144	120	100	90	72	60	50	36	30	24	20	18	15	12	10
Applicable gear head	MX9G3B to MX9G180B (ball bearing)	50Hz	0.66 (5.84)	0.78 (6.90)	1.08 (9.56)	1.27 (11.2)	1.57 (13.9)	1.86 (16.5)	2.25 (19.9)	2.74 (24.3)	3.23 (28.6)	3.92 (34.7)	4.41 (39.0)	5.29 (46.8)	6.37 (56.4)	7.94 (70.3)	9.80 (86.7)						
		60Hz	0.55 (4.87)	0.66 (5.84)	0.90 (7.97)	1.08 (9.56)	1.27 (11.2)	1.57 (13.9)	1.76 (15.6)	2.25 (19.9)	2.74 (24.3)	3.23 (28.6)	3.53 (31.2)	4.41 (39.0)	5.29 (46.8)	6.37 (56.4)	8.82 (78.1)	9.80 (86.7)					
Rotational direction		Same as motor rotational direction											Reverse to motor rotational direction										

Permissible torque at output shaft of gear head using decimal gear head

Applicable gear head		Reduction ratio	Speed (r/min)													
Bearing	Decimal gear head		200	250	300	360	500	600	750	900	1000	1200	1500	1800		
		MX9G□B (ball bearing)	MX9G10XB	50Hz	9.80 (86.7)	9.80 (86.7)	9.80 (86.7)	9.80 (86.7)	9.80 (86.7)	9.80 (86.7)	9.80 (86.7)	9.80 (86.7)	9.80 (86.7)	9.80 (86.7)	9.80 (86.7)	9.80 (86.7)
60Hz	9			7.2	6	5	3.6	3	2.4	2	1.8	1.5	1.2	1		
MX9G□M (metal bearing)		Permissible torque	Same as motor rotational direction													
Rotational direction		Reverse to motor rotational direction														

Connection diagram

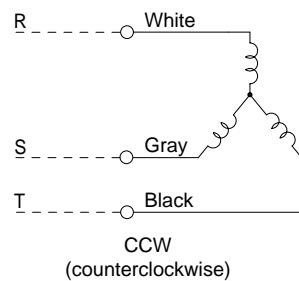

Change any two lead wires of R, S and T for CW rotation.

Speed-torque characteristics

M9MX40G4Y

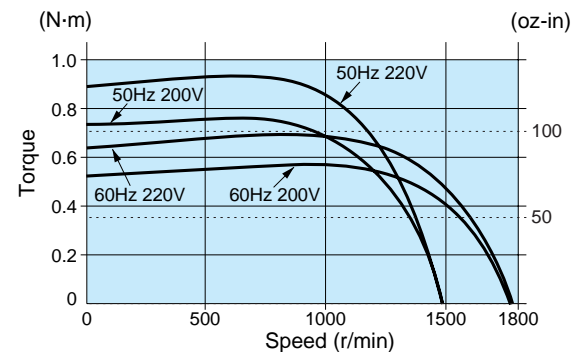

Motor (dimensions)

Scale: 1/3, Unit: mm (inch)

M9MX40G4Y 4P 40 W 200 V / 220 V

Mass	Helical gear	Module	Number of teeth
2.4 kg 5.29 lb		0.55	9

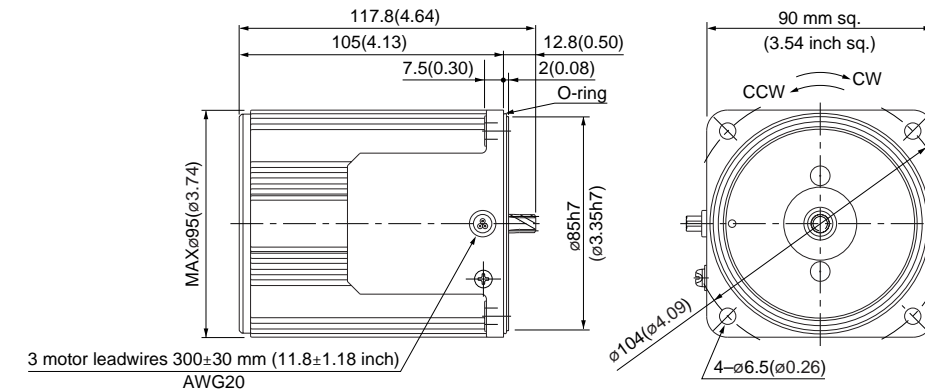

Gear head (dimensions)

Scale: 1/3, Unit: mm (inch)

MX9G□B (ball bearing) / MX9G□M (metal bearing) Mass 0.8 kg (1.76 lb)

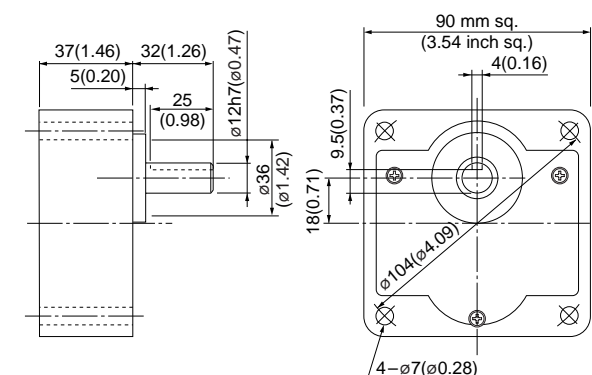

Key and keyway (dimensions) [attachment]

MX9G□B(M)

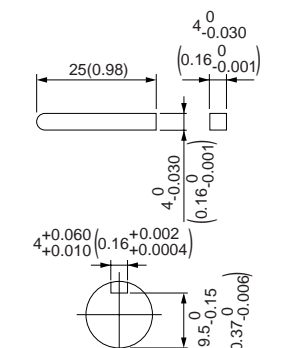

* Please read your User's manual carefully so that you will understand the operation and safety precautions before attempting to operate the system.

(Note) Because the dimensions may be subject to change, also check the determinate dimensions if the gear head is to be used for design.

Induction motor
 Reversible motor
 3-phase motor
 Electromagnetic brake motor
 Variable speed induction motor
 Variable speed reversible motor
 Variable speed electromagnetic single-phase motor
 Variable speed unit motor
 C&B motor
 2-pole round shaft motor
 Gear head
 Gear head -inch (U.S.A.)

Specifications

Size	Motor model No.	Number of pole (P)	Output (W)	Voltage (V)	Frequency (Hz)	Rating (min)	Rating				Starting current (A)	Starting torque N-m (oz-in)
							Input (W)	Current (A)	Speed (r/min)	Torque N-m (oz-in)		
90 mm sq.	M9MX40G4YG M9MX40G4YGA	4	40	200	50	Cont.	69	0.31	1350	0.28 (39.7)	0.90	0.72 (102)
					60		68	0.29	1625	0.24 (34.0)	0.82	0.51 (72.2)
				220	60	66	0.28	1675	0.23 (32.6)	0.91	0.63 (89.2)	
				230	60	66	0.29	1675	0.23 (32.6)	0.96	0.69 (97.7)	

• The specifications and wire connections of the round shaft motor are the same as those of the pinion shaft type. For the dimensional outline drawing, refer to page B-164.
 • The models with a motor model number to which "A" is suffixed are not sold or available in Japan.

Permissible torque at output shaft of gear head

* The speed shown below is a calculated value based on the synchronous rotational speed. Depending on the load, the speed is less than the indicated value by 2 to 20%.

Unit of permissible torque: upper (N·m) / lower (lb·in)

Reduction ratio	Unit of permissible torque: upper (N·m) / lower (lb·in)																							
	3	3.6	5	6	7.5	9	10	12.5	15	18	20	25	30	36	50	60	75	90	100	120	150	180		
Speed (r/min)																								
	50Hz	500	416.7	300	250	200	166.7	150	120	100	83.3	75	60	50	41.7	30	25	20	16.7	15	12.5	10	8.3	
	60Hz	600	500	360	300	240	200	180	144	120	100	90	72	60	50	36	30	24	20	18	15	12	10	
Applicable gear head	MX9G3B to MX9G180B (ball bearing)	50Hz	0.66 (5.84)	0.78 (6.90)	1.08 (9.56)	1.27 (11.2)	1.57 (13.9)	1.86 (16.5)	2.25 (19.9)	2.74 (24.3)	3.23 (28.6)	3.92 (34.7)	4.41 (39.0)	5.29 (46.8)	6.37 (56.4)	7.94 (70.3)	9.80 (86.7)							
		60Hz	0.55 (4.87)	0.66 (5.84)	0.90 (7.97)	1.08 (9.56)	1.27 (11.2)	1.57 (13.9)	1.76 (15.6)	2.25 (19.9)	2.74 (24.3)	3.23 (28.6)	3.53 (31.2)	4.41 (39.0)	5.29 (46.8)	6.37 (56.4)	8.82 (78.1)	9.80 (86.7)						
	MX9G3M to MX9G180M (metal bearing)	50Hz	0.66 (5.84)	0.78 (6.90)	1.08 (9.56)	1.27 (11.2)	1.57 (13.9)	1.86 (16.5)	2.25 (19.9)	2.74 (24.3)	3.23 (28.6)	3.92 (34.7)	4.41 (39.0)	5.29 (46.8)	6.37 (56.4)	7.94 (70.3)	9.80 (86.7)							
	60Hz	0.55 (4.87)	0.66 (5.84)	0.90 (7.97)	1.08 (9.56)	1.27 (11.2)	1.57 (13.9)	1.76 (15.6)	2.25 (19.9)	2.74 (24.3)	3.23 (28.6)	3.53 (31.2)	4.41 (39.0)	5.29 (46.8)	6.37 (56.4)	8.82 (78.1)	9.80 (86.7)							
Rotational direction	Same as motor rotational direction											Reverse to motor rotational direction												

Permissible torque at output shaft of gear head using decimal gear head

Applicable gear head		Reduction ratio	Reduction ratio												
Bearing	Decimal gear head		Speed (r/min)	200	250	300	360	500	600	750	900	1000	1200	1500	1800
		MX9G□B (ball bearing)		MX9G10XB	50Hz	9.80 (86.7)	9.80 (86.7)	9.80 (86.7)	9.80 (86.7)	9.80 (86.7)	9.80 (86.7)	9.80 (86.7)	9.80 (86.7)	9.80 (86.7)	9.80 (86.7)
60Hz	9.80 (86.7)		9.80 (86.7)		9.80 (86.7)	9.80 (86.7)	9.80 (86.7)	9.80 (86.7)	9.80 (86.7)	9.80 (86.7)	9.80 (86.7)	9.80 (86.7)	9.80 (86.7)	9.80 (86.7)	9.80 (86.7)
MX9G□M (metal bearing)		Permissible torque	Same as motor rotational direction												
		Rotational direction	Reverse to motor rotational direction												

Connection diagram

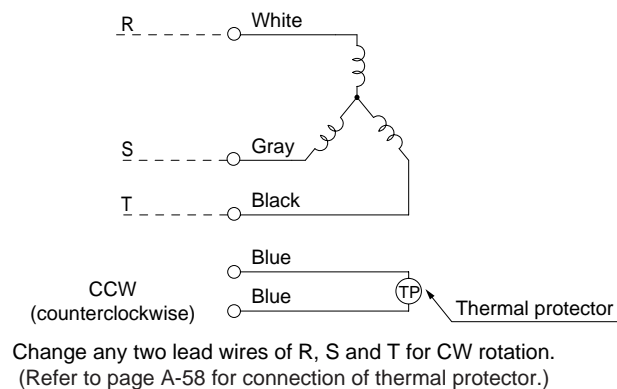

Speed-torque characteristics

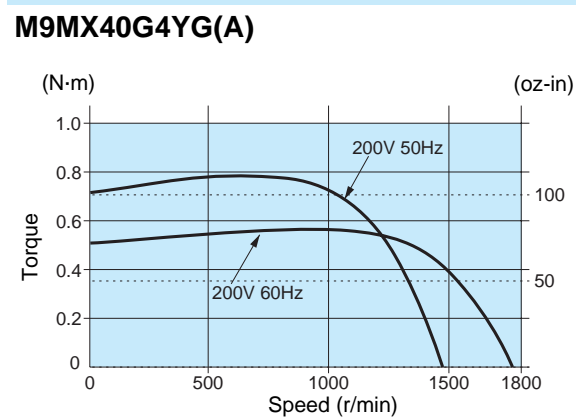

Motor (dimensions)

Scale: 1/3, Unit: mm (inch)

M9MX40G4YG(A) 4P 40 W 200 V / 220 V / 230 V

Mass	Helical gear	Module	Number of teeth
2.4 kg 5.29 lb		0.55	9

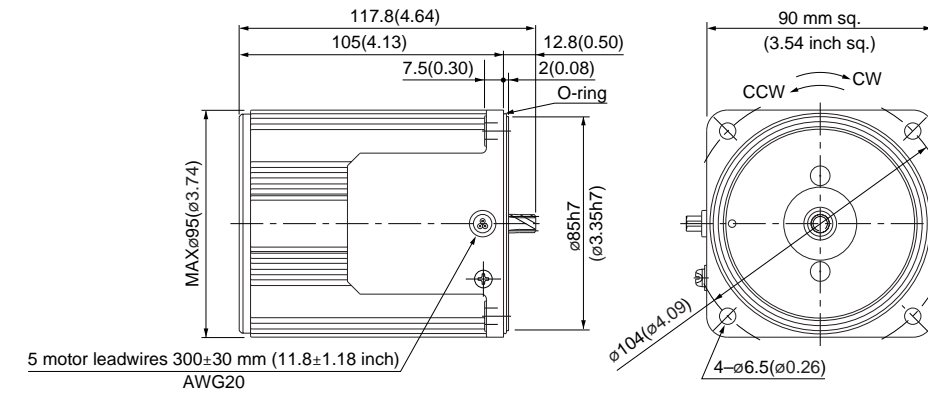

Gear head (dimensions)

Scale: 1/3, Unit: mm (inch)

MX9G□B (ball bearing) / **MX9G□M** (metal bearing) Mass 0.8 kg (1.76 lb)

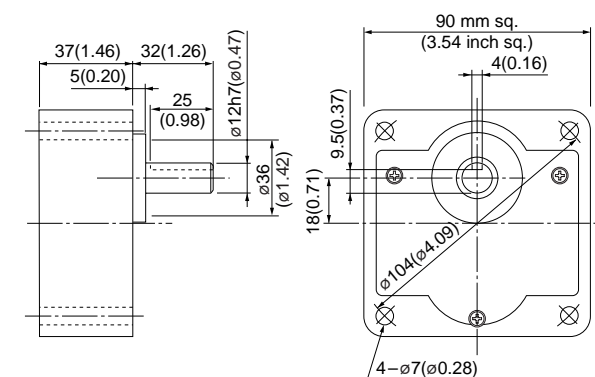

Key and keyway (dimensions) [attachment]

MX9G□B(M)

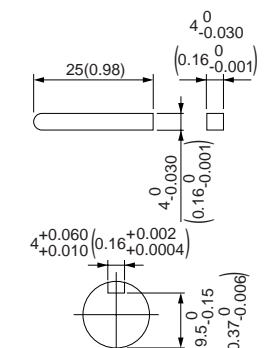

(Note) Because the dimensions may be subject to change, also check the determinate dimensions if the gear head is to be used for design.

Specifications

Size	Motor model No.	Number of pole (P)	Output (W)	Voltage (V)	Frequency (Hz)	Rating (min)	Rating				Starting current (A)	Starting torque N-m (oz-in)
							Input (W)	Current (A)	Speed (r/min)	Torque N-m (oz-in)		
90 mm sq.	M9MZ60G4Y	4	60	200	50	Cont.	101	0.45	1350	0.42 (59.5)	1.3	1.0 (142)
							96	0.41	1625	0.35 (49.6)	1.2	0.69 (97.7)
				220	50	Cont.	103	0.46	1375	0.41 (58.1)	1.5	1.2 (170)
							98	0.40	1650	0.34 (48.1)	1.3	0.87 (123)

* The specifications and wire connections of the round shaft motor are the same as those of the pinion shaft type. For the dimensional outline drawing, refer to page B-164.

Permissible torque at output shaft of gear head

* The speed shown below is a calculated value based on the synchronous rotational speed. Depending on the load, the speed is less than the indicated value by 2 to 20%.

Unit of permissible torque: upper (N·m) / lower (lb·in)

Reduction ratio	Speed (r/min)																							
	3	3.6	5	6	7.5	9	10	12.5	15	18	20	25	30	36	50	60	75	90	100	120	150	180	200	
Speed (r/min)																								
	50Hz	500	416.7	300	250	200	166.7	150	120	100	83.3	75	60	50	41.7	30	25	20	16.7	15	12.5	10	8.3	7.5
	60Hz	600	500	360	300	240	200	180	144	120	100	90	72	60	50	36	30	24	20	18	15	12	10	9
Applicable gear head	MZ9G3B to MZ9G200B (ball bearing / hinge not attached)	50Hz	0.98 (8.7)	1.18 (10.4)	1.57 (13.9)	1.96 (17.3)	2.35 (20.8)	2.94 (26.0)	3.14 (27.8)	3.92 (34.7)	4.70 (41.6)	5.59 (49.5)	6.27 (55.5)	7.55 (66.8)	9.11 (80.6)	11.0 (97.4)	15.2 (135)	17.8 (158)						19.6 (173)
		60Hz	0.78 (6.9)	0.98 (8.7)	1.37 (12.1)	1.57 (13.9)	1.96 (17.3)	2.35 (20.8)	2.65 (23.5)	3.33 (29.5)	3.92 (34.7)	4.70 (41.6)	5.29 (46.8)	6.47 (57.3)	7.55 (66.8)	9.11 (80.6)	12.6 (112)	15.2 (135)						19.6 (173)
Rotational direction	Same as motor rotational direction				Reverse to motor rotational direction				Same as motor rotational direction															

Permissible torque at output shaft of gear head using decimal gear head

Applicable gear head		Reduction ratio	Speed (r/min)												
Bearing	Decimal gear head		50Hz	60Hz	6	5	4.2	3	2.5	2	1.7	1.5	1.3	1	0.8
MZ9G□B (ball bearing / Hinge not attached) MY9G□B (ball bearing / Hinge attached)	MZ9G10XB	Permissible torque	N-m (lb-in)	19.6 (173)	19.6 (173)	19.6 (173)	19.6 (173)	19.6 (173)	19.6 (173)	19.6 (173)	19.6 (173)	19.6 (173)	19.6 (173)	19.6 (173)	19.6 (173)
		Rotational direction	Reverse to motor rotational direction	Same as motor rotational direction											

Connection diagram

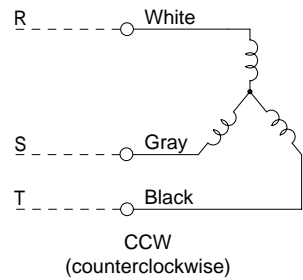

Change any two lead wires of R, S and T for CW rotation.

Speed-torque characteristics

M9MZ60G4Y

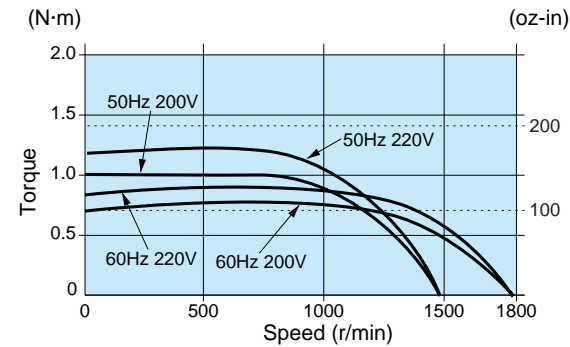

Motor (dimensions)

Scale: 1/4, Unit: mm (inch)

M9MZ60G4Y 4P 60 W 200 V / 220 V (with fan)

Mass	Helical gear	Module	Number of teeth
2.7 kg 5.95 lb		0.6	9

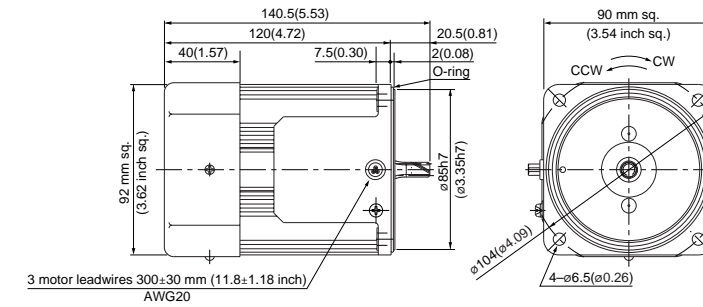

Gear head (dimensions)

Scale: 1/4, Unit: mm (inch)

MZ9G□B (ball bearing / hinge not attached)
Mass 1.4 kg (3.09 lb)

MY9G□B (ball bearing / hinge attached)
Mass 1.4 kg (3.09 lb)

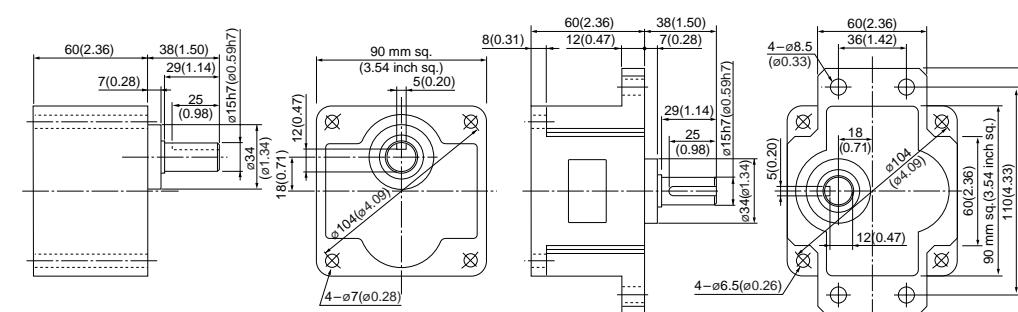

Key and keyway (dimensions) [attachment]

MZ9G□B
MY9G□B

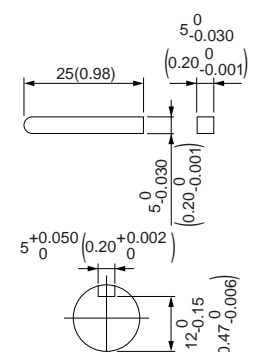

Note) MZ / MY is available for a gear head of either type.

(Note) Because the dimensions may be subject to change, also check the determinate dimensions if the gear head is to be used for design.

Specifications

Size	Motor model No.	Number of pole (P)	Output (W)	Voltage (V)	Frequency (Hz)	Rating (min)	Rating				Starting current (A)	Starting torque N-m (oz-in)
							Input (W)	Current (A)	Speed (r/min)	Torque N-m (oz-in)		
90 mm sq.	M9MZ60G4YG M9MZ60G4YGA	4	60	200	50	Cont.	101	0.45	1350	0.42 (59.5)	1.3	1.0 (142)
							96	0.41	1625	0.35 (49.6)	1.2	0.69 (97.7)
							98	0.40	1650	0.35 (49.6)	1.3	0.87 (123)
							98	0.41	1675	0.34 (48.1)	1.4	1.0 (142)

• The specifications and wire connections of the round shaft motor are the same as those of the pinion shaft type. For the dimensional outline drawing, refer to page B-164.
 • The models with a motor model number to which "A" is suffixed are not sold or available in Japan.

Permissible torque at output shaft of gear head

* The speed shown below is a calculated value based on the synchronous rotational speed. Depending on the load, the speed is less than the indicated value by 2 to 20%.

Unit of permissible torque: upper (N·m) / lower (lb·in)

Reduction ratio	Speed (r/min)																						
	3	3.6	5	6	7.5	9	10	12.5	15	18	20	25	30	36	50	60	75	90	100	120	150	180	200
50Hz	500	416.7	300	250	200	166.7	150	120	100	83.3	75	60	50	41.7	30	25	20	16.7	15	12.5	10	8.3	7.5
60Hz	600	500	360	300	240	200	180	144	120	100	90	72	60	50	36	30	24	20	18	15	12	10	9
Applicable gear head	Same as motor rotational direction												Reverse to motor rotational direction										
	Same as motor rotational direction												Same as motor rotational direction										

Permissible torque at output shaft of gear head using decimal gear head

Applicable gear head		Reduction ratio	Speed (r/min)												
Bearing	Decimal gear head		50Hz	60Hz	6	5	4.2	3	2.5	2	1.7	1.5	1.3	1	0.8
MZ9G□B (ball bearing / Hinge not attached)	MZ9G10XB	Permissible torque	N-m (lb-in)	19.6 (173)	19.6 (173)	19.6 (173)	19.6 (173)	19.6 (173)	19.6 (173)	19.6 (173)	19.6 (173)	19.6 (173)	19.6 (173)	19.6 (173)	19.6 (173)
			Rotational direction	Reverse to motor rotational direction	Same as motor rotational direction										

Connection diagram

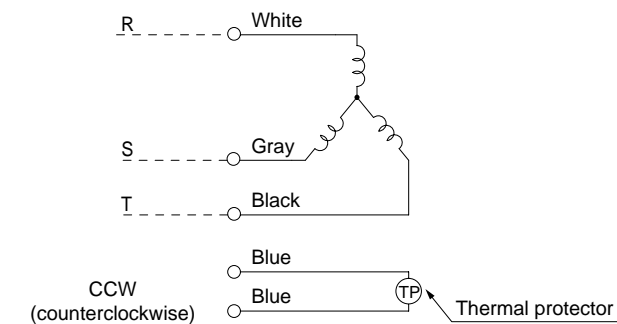

Change any two lead wires of R, S and T for CW rotation. (Refer to page A-58 for connection of thermal protector.)

Speed-torque characteristics

M9MZ60G4YG(A)

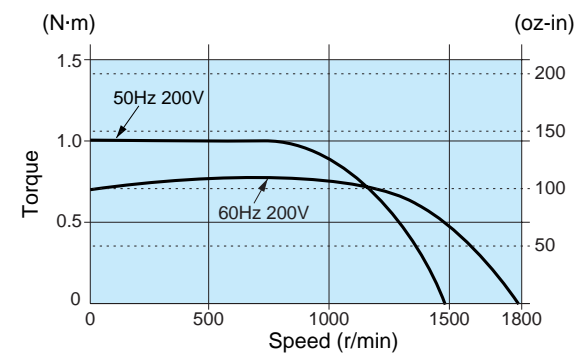

Motor (dimensions)

Scale: 1/4, Unit: mm (inch)

M9MZ60G4YG(A) 4P 60 W 200 V / 220 V / 230 V (with fan)

Mass	Helical gear	Module	Number of teeth
2.7 kg 5.95 lb		0.6	9

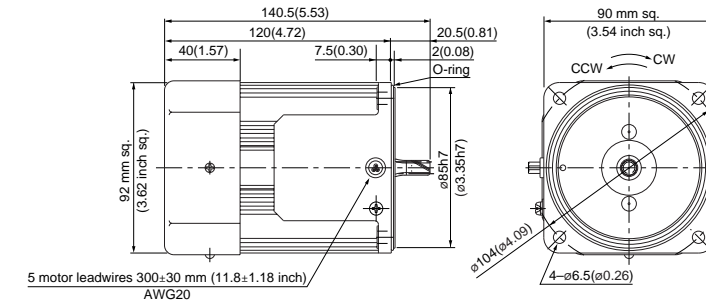

Gear head (dimensions)

Scale: 1/4, Unit: mm (inch)

MZ9G□B (ball bearing / hinge not attached)
Mass 1.4 kg (3.09 lb)

MY9G□B (ball bearing / hinge attached)
Mass 1.4 kg (3.09 lb)

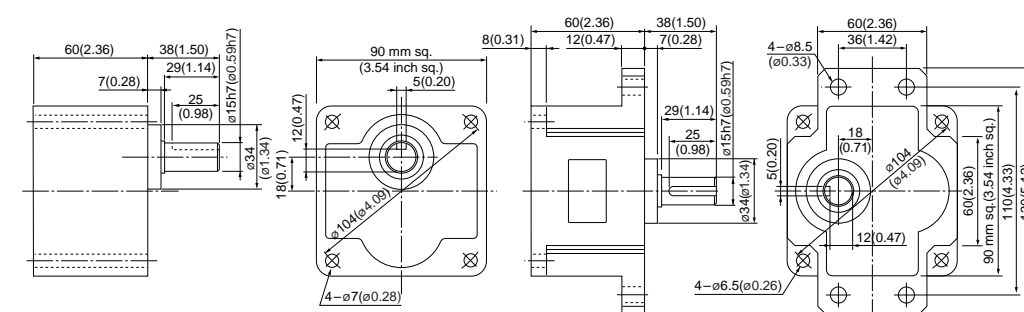

Key and keyway (dimensions) [attachment]

MZ9G□B
MY9G□B

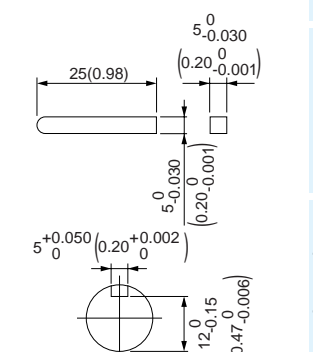

Note) MZ / MY is available for a gear head of either type.

(Note) Because the dimensions may be subject to change, also check the determinate dimensions if the gear head is to be used for design.

* Please read your User's manual carefully so that you will understand the operation and safety precautions before attempting to operate the system.

Specifications

Size	Motor model No.	Number of pole (P)	Output (W)	Voltage (V)	Frequency (Hz)	Rating (min)	Rating				Starting current (A)	Starting torque N-m (oz-in)
							Input (W)	Current (A)	Speed (r/min)	Torque N-m (oz-in)		
90 mm sq.	M9MZ90G4Y	4	90	200	50	Cont.	141	0.62	1350	0.63 (89.2)	2.0	1.6 (227)
							137	0.56	1625	0.53 (75.1)	1.8	1.1 (156)
				220	50	Cont.	143	0.65	1400	0.62 (87.8)	2.2	2.0 (283)
							137	0.56	1650	0.52 (73.6)	2.0	1.4 (198)

The specifications and wire connections of the round shaft motor are the same as those of the pinion shaft type. For the dimensional outline drawing, refer to page B-164.

Permissible torque at output shaft of gear head

* The speed shown below is a calculated value based on the synchronous rotational speed. Depending on the load, the speed is less than the indicated value by 2 to 20%.

Unit of permissible torque: upper (N·m) / lower (lb·in)

Reduction ratio	Unit of permissible torque: upper (N·m) / lower (lb·in)																							
	3	3.6	5	6	7.5	9	10	12.5	15	18	20	25	30	36	50	60	75	90	100	120	150	180	200	
Speed (r/min)																								
	50Hz	500	416.7	300	250	200	166.7	150	120	100	83.3	75	60	50	41.7	30	25	20	16.7	15	12.5	10	8.3	7.5
	60Hz	600	500	360	300	240	200	180	144	120	100	90	72	60	50	36	30	24	20	18	15	12	10	9
Applicable gear head	MZ9G3B to MZ9G200B (ball bearing / hinge not attached)	50Hz	1.37 (12.1)	1.67 (14.8)	2.25 (19.9)	2.74 (24.3)	3.43 (30.4)	4.12 (36.5)	5.68 (50.3)	6.76 (59.8)	8.04 (71.2)	9.02 (79.8)	10.9 (96.5)	13.0 (115)	15.7 (139)	19.6 (173)								
	MY9G3B to MY9G200B (ball bearing / hinge attached)	60Hz	1.18 (10.4)	1.37 (12.1)	1.86 (16.5)	2.25 (19.9)	2.84 (25.1)	3.43 (30.4)	3.72 (32.9)	4.70 (41.6)	5.68 (50.3)	6.76 (59.8)	7.55 (66.8)	9.21 (81.5)	10.9 (96.5)	13.0 (115)	18.3 (162)							
Rotational direction	Same as motor rotational direction						Reverse to motor rotational direction						Same as motor rotational direction											

Permissible torque at output shaft of gear head using decimal gear head

Applicable gear head		Reduction ratio	Reduction ratio													
Bearing	Decimal gear head		Speed (r/min)	50Hz	60Hz	6	5	4.2	3	2.5	2	1.7	1.5	1.3	1	0.8
MZ9G□B (ball bearing / hinge not attached)	MZ9G10XB	Permissible torque	N-m (lb-in)	19.6 (173)	19.6 (173)	19.6 (173)	19.6 (173)	19.6 (173)	19.6 (173)	19.6 (173)	19.6 (173)	19.6 (173)	19.6 (173)	19.6 (173)	19.6 (173)	19.6 (173)
				Rotational direction	Reverse to motor rotational direction		Same as motor rotational direction									

Motor (dimensions)

Scale: 1/4, Unit: mm (inch)

M9MZ90G4Y 4P 90 W 200 V / 220 V (with fan)

Mass 3.2 kg 7.05 lb
Helical gear
Module 0.6
Number of teeth 9

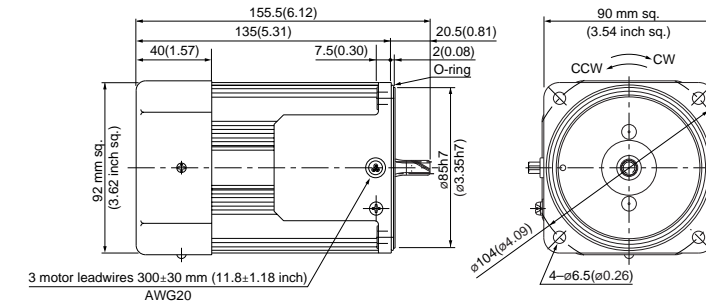

* Diameter of applicable cable to be $\varnothing 8(\varnothing 0.31)$ to $\varnothing 12(\varnothing 0.47)$.

Connection diagram

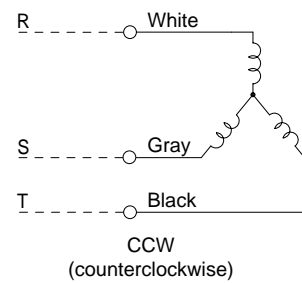

Change any two lead wires of R, S and T for CW rotation.

Speed-torque characteristics

M9MZ90G4Y

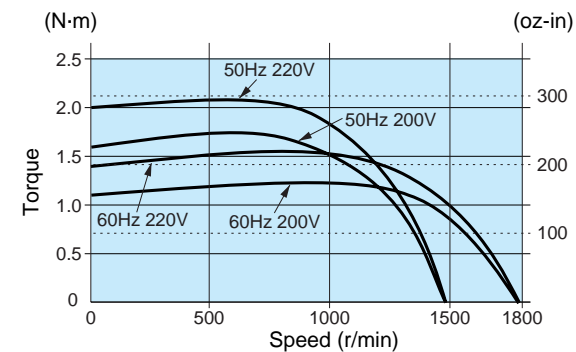

Gear head (dimensions)

Scale: 1/4, Unit: mm (inch)

MZ9G□B (ball bearing / hinge not attached)
Mass 1.4 kg (3.09 lb)

MY9G□B (ball bearing / hinge attached)
Mass 1.4 kg (3.09 lb)

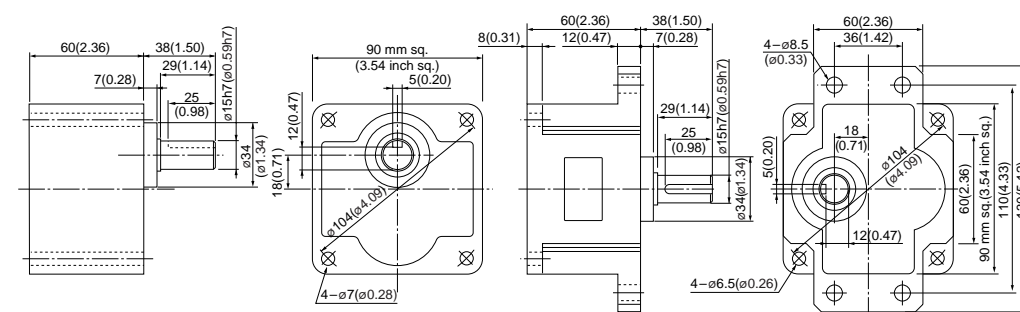

Key and keyway (dimensions) [attachment]

MZ9G□B
MY9G□B

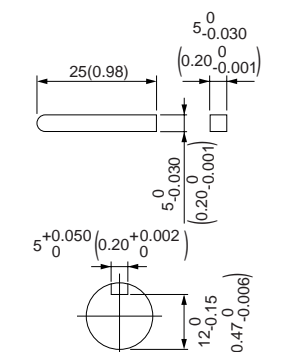

Note) MZ / MY is available for a gear head of either type.

(Note) Because the dimensions may be subject to change, also check the determinate dimensions if the gear head is to be used for design.

* Please read your User's manual carefully so that you will understand the operation and safety precautions before attempting to operate the system.

Specifications

Size	Motor model No.	Number of pole (P)	Output (W)	Voltage (V)	Frequency (Hz)	Rating (min)	Rating				Starting current (A)	Starting torque N-m (oz-in)
							Input (W)	Current (A)	Speed (r/min)	Torque N-m (oz-in)		
90 mm sq.	M9MZ90G4YG M9MZ90G4YGA	4	90	200	50	Cont.	142	0.62	1350	0.63 (89.2)	2.0	1.6 (227)
					60		138	0.56	1625	0.53 (75.1)	1.8	1.1 (156)
				220	60	137	0.56	1650	0.52 (73.6)	2.0	1.4 (198)	
				230	60	137	0.58	1675	0.51 (72.2)	2.1	1.6 (227)	

• The specifications and wire connections of the round shaft motor are the same as those of the pinion shaft type. For the dimensional outline drawing, refer to page B-164.
 • The models with a motor model number to which "A" is suffixed are not sold or available in Japan.

Permissible torque at output shaft of gear head

* The speed shown below is a calculated value based on the synchronous rotational speed. Depending on the load, the speed is less than the indicated value by 2 to 20%.

Unit of permissible torque: upper (N·m) / lower (lb·in)

Reduction ratio	Speed (r/min)																							
	3	3.6	5	6	7.5	9	10	12.5	15	18	20	25	30	36	50	60	75	90	100	120	150	180	200	
Speed (r/min)																								
	50Hz	500	416.7	300	250	200	166.7	150	120	100	83.3	75	60	50	41.7	30	25	20	16.7	15	12.5	10	8.3	7.5
	60Hz	600	500	360	300	240	200	180	144	120	100	90	72	60	50	36	30	24	20	18	15	12	10	9
Applicable gear head	50Hz	MZ9G3B to MZ9G200B (ball bearing / hinge not attached)												19.6 (173)										
		MY9G3B to MY9G200B (ball bearing / hinge attached)												19.6 (173)										
Rotational direction	60Hz	Same as motor rotational direction												Reverse to motor rotational direction										

Permissible torque at output shaft of gear head using decimal gear head

Applicable gear head		Reduction ratio	Speed (r/min)											
Bearing	Decimal gear head		50Hz	60Hz	6	5	4.2	3	2.5	2	1.7	1.5	1.3	1
MZ9G□B (ball bearing / hinge not attached) MY9G□B (ball bearing / hinge attached)	MZ9G10XB	Permissible torque	N-m (lb-in)											
			19.6 (173)											
Rotational direction		Reverse to motor rotational direction												

Connection diagram

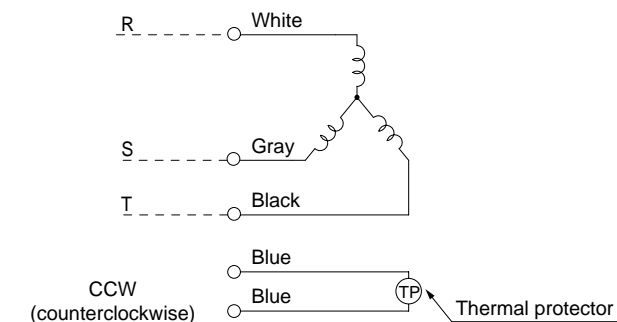

Change any two lead wires of R, S and T for CW rotation. (Refer to page A-58 for connection of thermal protector.)

Speed-torque characteristics

M9MZ90G4YG(A)

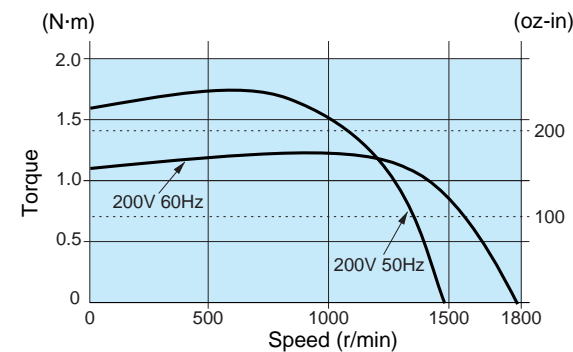

Motor (dimensions)

Scale: 1/4, Unit: mm (inch)

M9MZ90G4YG(A) 4P 90 W 200 V / 220 V / 230 V (with fan)

Mass	Helical gear	Module	Number of teeth
3.2 kg 7.05 lb		0.6	9

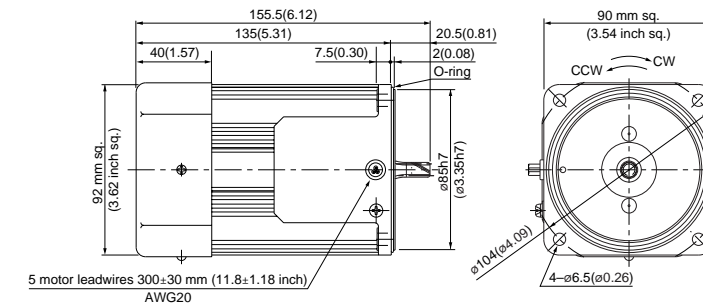

Gear head (dimensions)

Scale: 1/4, Unit: mm (inch)

MZ9G□B (ball bearing / hinge not attached)
Mass 1.4 kg (3.09 lb)

MY9G□B (ball bearing / hinge attached)
Mass 1.4 kg (3.09 lb)

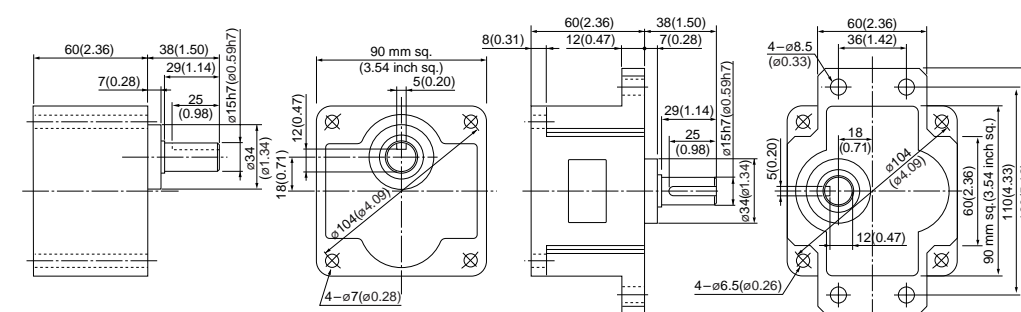

Key and keyway (dimensions) [attachment]

MZ9G□B
MY9G□B

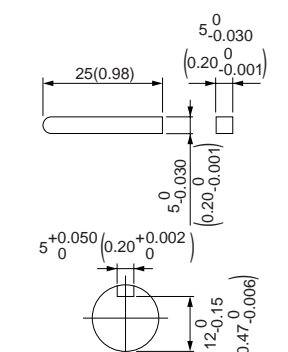

Note) MZ / MY is available for a gear head of either type.

(Note) Because the dimensions may be subject to change, also check the determinate dimensions if the gear head is to be used for design.

Specifications

Size	Motor model No.	Number of pole (P)	Output (W)	Voltage (V)	Frequency (Hz)	Rating (min)	Rating				Starting current (A)	Starting torque N-m (oz-in)
							Input (W)	Current (A)	Speed (r/min)	Torque N-m (oz-in)		
80 mm sq.	M8MX25GK4Y	4	25	200	50	Cont.	50	0.25	1350	0.18 (25.5)	0.62	0.54 (76.5)
					60		47	0.22	1625	0.15 (21.2)	0.58	0.40 (56.6)
				220	50	Cont.	54	0.27	1375	0.18 (25.5)	0.67	0.66 (93.5)
					60		49	0.23	1650	0.15 (21.2)	0.64	0.50 (70.8)

The specifications and wire connections of the round shaft motor are the same as those of the pinion shaft type. For the dimensional outline drawing, refer to page B-165.

Permissible torque at output shaft of gear head

* The speed shown below is a calculated value based on the synchronous rotational speed. Depending on the load, the speed is less than the indicated value by 2 to 20%.

Unit of permissible torque: upper (N-m) / lower (lb-in)

Reduction ratio	Speed (r/min)																								
	50Hz	60Hz	3	3.6	5	6	7.5	9	10	12.5	15	18	20	25	30	36	50	60	75	90	100	120	150	180	
Applicable gear head	MX8G3B to MX8G180B (ball bearing)	50Hz	0.39 (3.45)	0.47 (4.16)	0.66 (5.84)	0.78 (6.90)	0.98 (8.67)	1.18 (10.4)	1.27 (11.2)	1.57 (13.9)	1.96 (17.3)	2.35 (20.8)	2.55 (22.6)	3.14 (27.8)	3.82 (33.8)	4.61 (40.8)	6.37 (56.4)	7.64 (67.6)							7.84 (69.4)
		60Hz	0.32 (2.83)	0.39 (3.45)	0.55 (4.87)	0.66 (5.84)	0.81 (7.17)	0.98 (8.67)	1.08 (9.56)	1.27 (11.2)	1.57 (13.9)	1.96 (17.3)	2.06 (18.2)	2.65 (23.5)	3.14 (27.8)	3.82 (33.8)	5.29 (46.8)	6.37 (56.4)							7.84 (69.4)
Rotational direction		Same as motor rotational direction												Reverse to motor rotational direction											

Permissible torque at output shaft of gear head using decimal gear head

Applicable gear head		Reduction ratio	Speed (r/min)														
Bearing	Decimal gear head		50Hz	60Hz	200	250	300	360	500	600	750	900	1000	1200	1500	1800	
MX8G□B (ball bearing) MX8G□M (metal bearing)	MX8G10XB	Permissible torque	N-m (lb-in)	7.84 (69.4)	7.84 (69.4)	7.84 (69.4)	7.84 (69.4)	7.84 (69.4)	7.84 (69.4)	7.84 (69.4)	7.84 (69.4)	7.84 (69.4)	7.84 (69.4)	7.84 (69.4)	7.84 (69.4)	7.84 (69.4)	
		Rotational direction	Same as motor rotational direction			Reverse to motor rotational direction											

Connection diagram

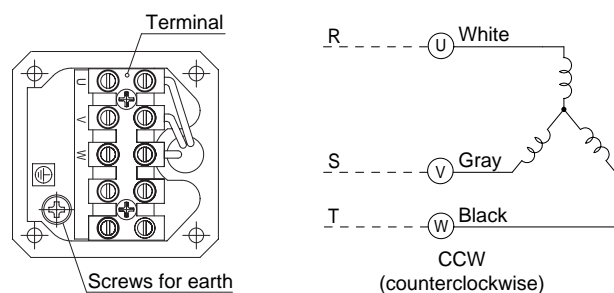

Change any two lead wires of U, V and W for CW rotation.

Speed-torque characteristics

M8MX25GK4Y

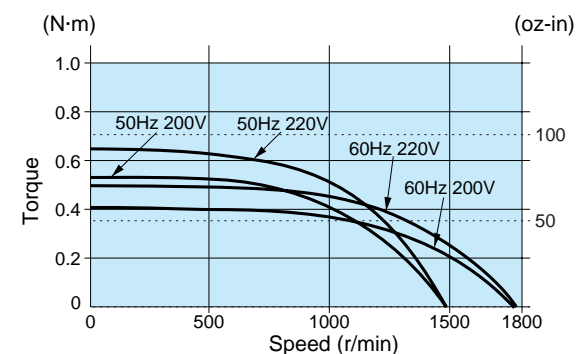

Motor (dimensions)

M8MX25GK4Y 4P 25 W 200 V / 220 V

Scale: 1/3, Unit: mm (inch)

Mass	Helical gear	Module	Number of teeth
1.8 kg 3.97 lb		0.5	9

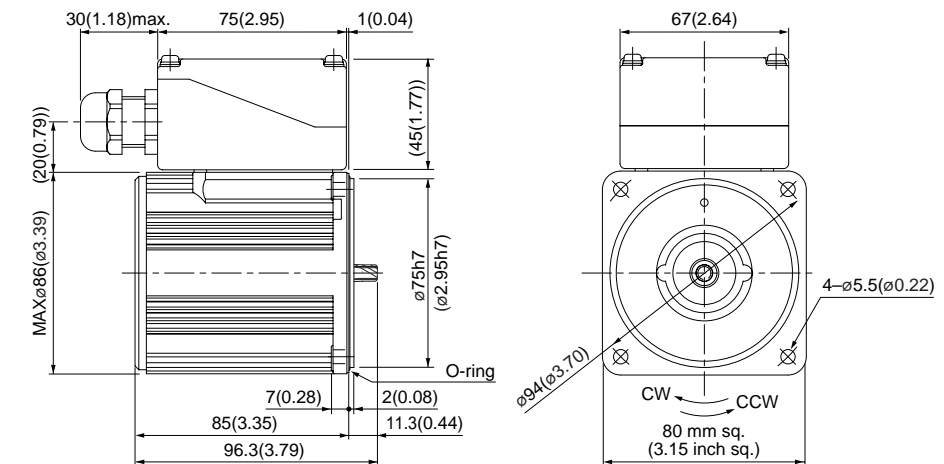

* Diameter of applicable cable to be $\phi 8(\phi 0.31)$ to $\phi 12(\phi 0.47)$.

Gear head (dimensions)

Scale: 1/3, Unit: mm (inch)

MX8G□B (ball bearing) / MX8G□M (metal bearing) Mass 0.6 kg (1.32 lb)

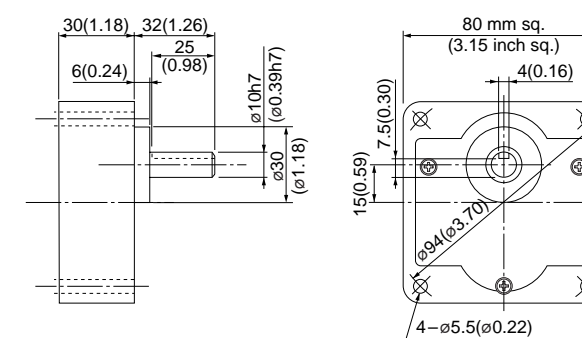

Key and keyway (dimensions) [attachment]

MX8G□B(M)

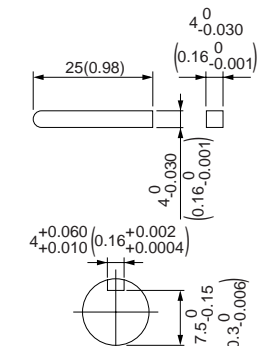

* Please read your User's manual carefully so that you will understand the operation and safety precautions before attempting to operate the system.

(Note) Because the dimensions may be subject to change, also check the determinate dimensions if the gear head is to be used for design.

Induction motor
 Reversible motor
 3-phase motor
 Electromagnetic brake motor
 Variable speed induction motor
 Variable speed reversible motor
 Variable speed electromagnetic single-phase motor
 Variable speed unit motor
 C&B motor
 2-pole round shaft motor
 Gear head
 Gear head -inch (U.S.A.)

3-phase motor (sealed connector)

US CE 80 mm (3.15 inch) sq. 25 W

Specifications

Size	Motor model No.	Number of pole (P)	Output (W)	Voltage (V)	Frequency (Hz)	Rating (min)	Rating				Starting current (A)	Starting torque N-m (oz-in)
							Input (W)	Current (A)	Speed (r/min)	Torque N-m (oz-in)		
80 mm sq.	M8MX25GK4YG M8MX25GK4YGA	4	25	200	50	Cont.	50	0.25	1350	0.18 (25.5)	0.62	0.54 (76.5)
							47	0.22	1625	0.15 (21.2)	0.58	0.40 (56.6)
				220	60		49	0.23	1650	0.14 (19.8)	0.64	0.50 (70.8)
				230	60		50	0.24	1675	0.14 (19.8)	0.65	0.54 (76.5)
	M8MX25GK4CG * M8MX25GK4CGA	4	25	380	50	Cont.	49	0.12	1325	0.18 (25.5)	0.29	0.50 (70.8)
							52	0.12	1325	0.18 (25.5)	0.32	0.56 (79.3)

- * Do not use an inverter to drive 380/400 V motor.
- The specifications and wire connections of the round shaft motor are the same as those of the pinion shaft type. For the dimensional outline drawing, refer to page B-165.
- The models with a motor model number to which "A" is suffixed are not sold or available in Japan.

Permissible torque at output shaft of gear head

* The speed shown below is a calculated value based on the synchronous rotational speed. Depending on the load, the speed is less than the indicated value by 2 to 20%.

Unit of permissible torque: upper (N·m) / lower (lb-in)

Reduction ratio	Speed (r/min)																						
	3	3.6	5	6	7.5	9	10	12.5	15	18	20	25	30	36	50	60	75	90	100	120	150	180	
Speed (r/min)	50Hz	500	416.7	300	250	200	166.7	150	120	100	83.3	75	60	50	41.7	30	25	20	16.7	15	12.5	10	8.3
	60Hz	600	500	360	300	240	200	180	144	120	100	90	72	60	50	36	30	24	20	18	15	12	10
Applicable gear head	MX8G3B to MX8G180B (ball bearing)	0.39 (3.45)	0.47 (4.16)	0.66 (5.84)	0.78 (6.90)	0.98 (8.67)	1.18 (10.4)	1.27 (11.2)	1.57 (13.9)	1.96 (17.3)	2.35 (20.8)	2.55 (22.6)	3.14 (27.8)	3.82 (33.8)	4.61 (40.8)	6.37 (56.4)	7.64 (67.6)						7.84 (69.4)
	MX8G3M to MX8G180M (metal bearing)	0.32 (2.83)	0.39 (3.45)	0.55 (4.87)	0.66 (5.84)	0.81 (7.17)	0.98 (8.67)	1.08 (9.56)	1.27 (11.2)	1.57 (13.9)	1.96 (17.3)	2.06 (18.2)	2.65 (23.5)	3.14 (27.8)	3.82 (33.8)	5.29 (46.8)	6.37 (56.4)						7.84 (69.4)
Rotational direction	Same as motor rotational direction											Reverse to motor rotational direction											

Permissible torque at output shaft of gear head using decimal gear head

Applicable gear head		Reduction ratio	Speed (r/min)													
Bearing	Decimal gear head		50Hz	7.5	6	5	4.2	3	2.5	2	1.7	1.5	1.3	1	0.8	
MX8G□B (ball bearing) MX8G□M (metal bearing)	MX8G10XB	Permissible torque	N·m (lb-in)	7.84 (69.4)	7.84 (69.4)	7.84 (69.4)	7.84 (69.4)	7.84 (69.4)	7.84 (69.4)	7.84 (69.4)	7.84 (69.4)	7.84 (69.4)	7.84 (69.4)	7.84 (69.4)	7.84 (69.4)	
		Rotational direction	Same as motor rotational direction	Reverse to motor rotational direction												

Connection diagram

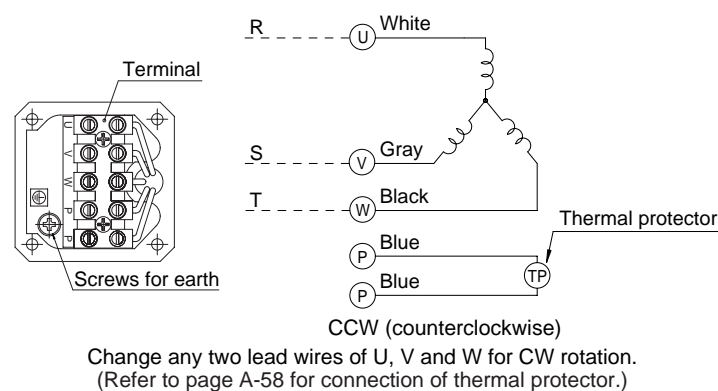

Speed-torque characteristics

M8MX25GK4YG(A) / M8MX25GK4CG(A)

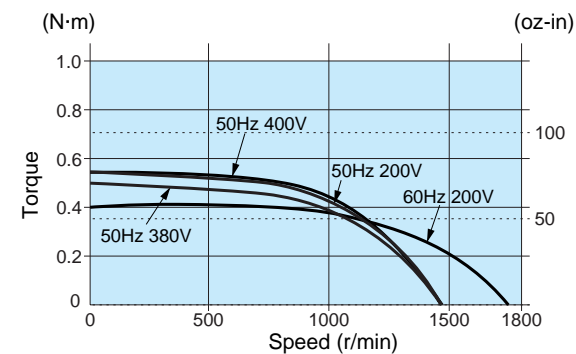

Motor (dimensions)

Scale: 1/3, Unit: mm (inch)

M8MX25GK4YG(A) 4P 25 W 200 V / 220 V / 230 V
M8MX25GK4CG(A) 4P 25 W 380 V / 400 V

Mass 1.8 kg 3.97 lb
Helical gear
Module 0.5
Number of teeth 9

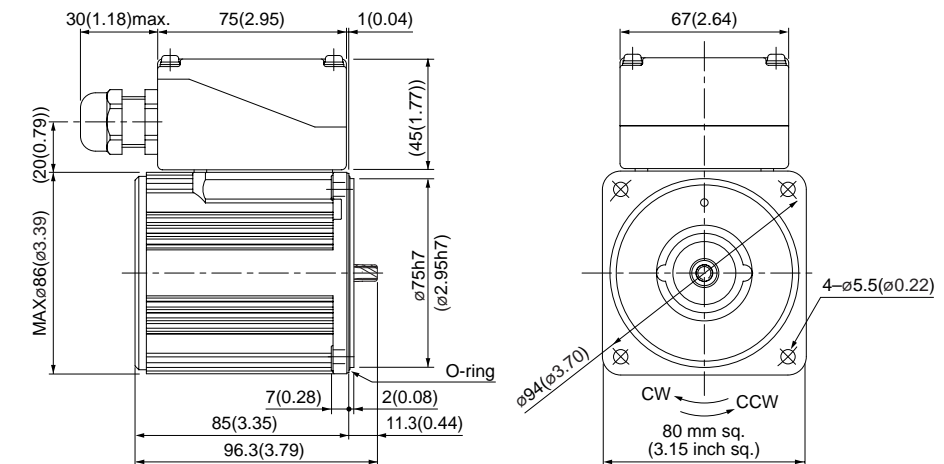

* Diameter of applicable cable to be $\phi 8(\phi 0.31)$ to $\phi 12(\phi 0.47)$.

Gear head (dimensions)

Scale: 1/3, Unit: mm (inch)

MX8G□B (ball bearing) / MX8G□M (metal bearing) Mass 0.6 kg (1.32 lb)

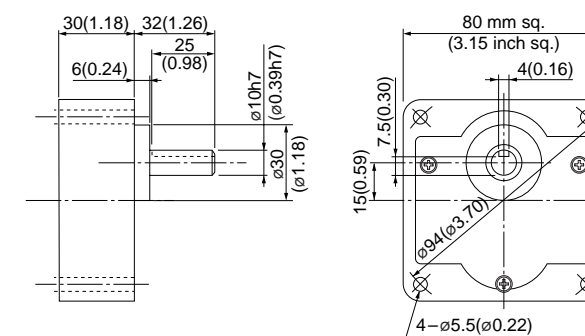

Key and keyway (dimensions) [attachment]

MX8G□B(M)

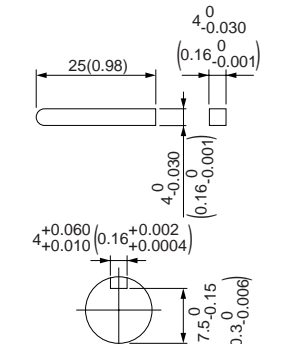

* Please read your User's manual carefully so that you will understand the operation and safety precautions before attempting to operate the system.

(Note) Because the dimensions may be subject to change, also check the determinate dimensions if the gear head is to be used for design.

Induction motor
Reversible motor
3-phase motor
Electromagnetic brake motor
Variable speed induction motor
Variable speed reversible motor
Variable speed electromagnetic brake single-phase motor
Variable speed unit motor
C&B motor
2-pole round shaft motor
Gear head
Gear head -inch (U.S.A.)

3-phase motor (sealed connector)

90 mm (3.54 inch) sq. 40 W

Specifications

Size	Motor model No.	Number of pole (P)	Output (W)	Voltage (V)	Frequency (Hz)	Rating (min)	Rating				Starting current (A)	Starting torque N-m (oz-in)
							Input (W)	Current (A)	Speed (r/min)	Torque N-m (oz-in)		
90 mm sq.	M9MX40GK4Y	4	40	200	50	Cont.	69	0.31	1350	0.28 (39.7)	0.90	0.72 (102)
							68	0.29	1625	0.24 (34.0)	0.82	0.51 (72.2)
				220	50	Cont.	70	0.32	1375	0.27 (38.2)	1.0	0.88 (125)
							66	0.28	1675	0.23 (32.6)	0.91	0.63 (89.2)

* The specifications and wire connections of the round shaft motor are the same as those of the pinion shaft type. For the dimensional outline drawing, refer to page B-165.

Permissible torque at output shaft of gear head

* The speed shown below is a calculated value based on the synchronous rotational speed. Depending on the load, the speed is less than the indicated value by 2 to 20%.

Unit of permissible torque: upper (N·m) / lower (lb-in)

Reduction ratio	Speed (r/min)																							
	50Hz	60Hz	3	3.6	5	6	7.5	9	10	12.5	15	18	20	25	30	36	50	60	75	90	100	120	150	180
Applicable gear head	MX9G3B to MX9G180B (ball bearing)	50Hz	0.66 (5.84)	0.78 (6.90)	1.08 (9.56)	1.27 (11.2)	1.57 (13.9)	1.86 (16.5)	2.25 (19.9)	2.74 (24.3)	3.23 (28.6)	3.92 (34.7)	4.41 (39.0)	5.29 (46.8)	6.37 (56.4)	7.94 (70.3)	9.80 (86.7)							9.80 (86.7)
		60Hz	0.55 (4.87)	0.66 (5.84)	0.90 (7.97)	1.08 (9.56)	1.27 (11.2)	1.57 (13.9)	1.76 (15.6)	2.25 (19.9)	2.74 (24.3)	3.23 (28.6)	3.53 (31.2)	4.41 (39.0)	5.29 (46.8)	6.37 (56.4)	8.82 (78.1)							9.80 (86.7)
Applicable gear head	MX9G3M to MX9G180M (metal bearing)	50Hz	0.66 (5.84)	0.78 (6.90)	1.08 (9.56)	1.27 (11.2)	1.57 (13.9)	1.86 (16.5)	2.25 (19.9)	2.74 (24.3)	3.23 (28.6)	3.92 (34.7)	4.41 (39.0)	5.29 (46.8)	6.37 (56.4)	7.94 (70.3)	9.80 (86.7)							9.80 (86.7)
		60Hz	0.55 (4.87)	0.66 (5.84)	0.90 (7.97)	1.08 (9.56)	1.27 (11.2)	1.57 (13.9)	1.76 (15.6)	2.25 (19.9)	2.74 (24.3)	3.23 (28.6)	3.53 (31.2)	4.41 (39.0)	5.29 (46.8)	6.37 (56.4)	8.82 (78.1)							9.80 (86.7)
Rotational direction		Same as motor rotational direction												Reverse to motor rotational direction										

Permissible torque at output shaft of gear head using decimal gear head

Applicable gear head		Reduction ratio		Speed (r/min)													
Bearing	Decimal gear head	Speed (r/min)	50Hz	7.5	6	5	4.2	3	2.5	2	1.7	1.5	1.3	1	0.8		
																60Hz	9
MX9G□B (ball bearing) MX9G□M (metal bearing)	MX9G10XB	Permissible torque	N-m (lb-in)	9.80 (86.7)	9.80 (86.7)	9.80 (86.7)	9.80 (86.7)	9.80 (86.7)	9.80 (86.7)	9.80 (86.7)	9.80 (86.7)	9.80 (86.7)	9.80 (86.7)	9.80 (86.7)	9.80 (86.7)	9.80 (86.7)	
		Rotational direction	Same as motor rotational direction				Reverse to motor rotational direction										

Connection diagram

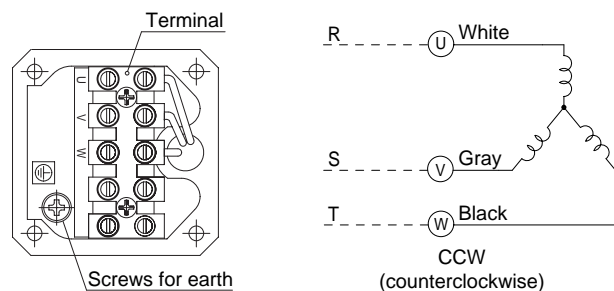

Change any two lead wires of U, V and W for CW rotation.

Speed-torque characteristics

M9MX40GK4Y

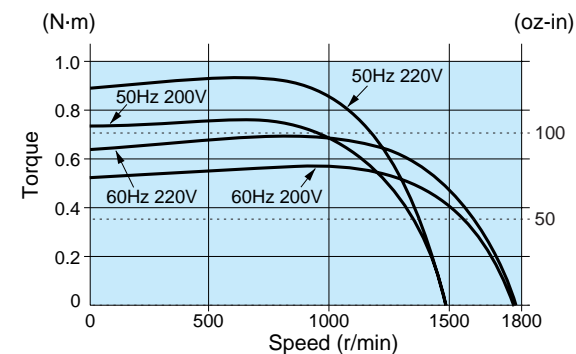

Motor (dimensions)

Scale: 1/3, Unit: mm (inch)

M9MX40GK4Y 4P 40 W 200 V / 220 V

Mass 2.8 kg 6.17 lb
Helical gear
Module 0.55
Number of teeth 9

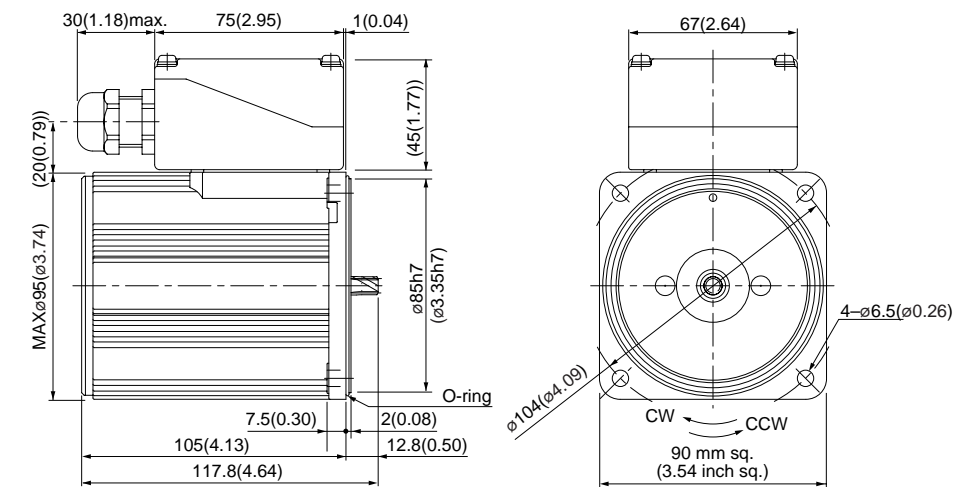

* Diameter of applicable cable to be ø8(ø0.31) to ø12(ø0.47).

Gear head (dimensions)

Scale: 1/3, Unit: mm (inch)

MX9G□B (ball bearing) / MX9G□M (metal bearing) Mass 0.8 kg (1.76 lb)

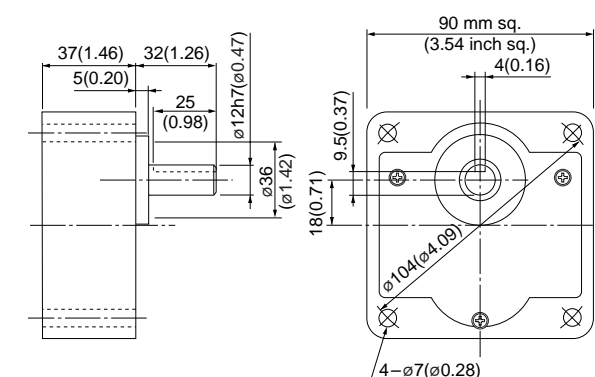

Key and keyway (dimensions) [attachment]

MX9G□B(M)

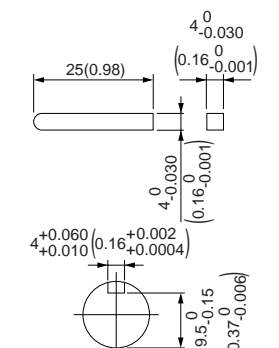

* Please read your User's manual carefully so that you will understand the operation and safety precautions before attempting to operate the system.

(Note) Because the dimensions may be subject to change, also check the determinate dimensions if the gear head is to be used for design.

Induction motor
Reversible motor
3-phase motor
Electromagnetic brake motor
Variable speed induction motor
Variable speed reversible motor
Variable speed electromagnetic single-phase motor
Variable speed unit motor
C&B motor
2-pole round shaft motor
Gear head
Gear head -inch (U.S.A.)

3-phase motor (sealed connector)

US CE 90 mm (3.54 inch) sq. 40 W

Specifications

Size	Motor model No.	Number of pole (P)	Output (W)	Voltage (V)	Frequency (Hz)	Rating (min)	Rating				Starting current (A)	Starting torque N-m (oz-in)
							Input (W)	Current (A)	Speed (r/min)	Torque N-m (oz-in)		
90 mm sq.	M9MX40GK4YG M9MX40GK4YGA	4	40	200	50	Cont.	69	0.31	1350	0.28 (39.7)	0.90	0.72 (102)
							68	0.29	1625	0.24 (34.0)	0.82	0.51 (72.2)
				220	60		66	0.28	1675	0.23 (32.6)	0.91	0.63 (89.2)
							230	60	66	0.29	1675	0.23 (32.6)
	M9MX40GK4CG * M9MX40GK4CGA	4	40	380	50	Cont.			68	0.15	1325	0.29 (41.1)
							66	0.15	1350	0.28 (39.7)	0.47	0.74 (105)

- * Do not use an inverter to drive 380/400 V motor.
- The specifications and wire connections of the round shaft motor are the same as those of the pinion shaft type. For the dimensional outline drawing, refer to page B-165.
- The models with a motor model number to which "A" is suffixed are not sold or available in Japan.

Permissible torque at output shaft of gear head

* The speed shown below is a calculated value based on the synchronous rotational speed. Depending on the load, the speed is less than the indicated value by 2 to 20%.

Unit of permissible torque: upper (N·m) / lower (lb-in)

Reduction ratio	Speed (r/min)																						
	3	3.6	5	6	7.5	9	10	12.5	15	18	20	25	30	36	50	60	75	90	100	120	150	180	
Speed (r/min)	50Hz	500	416.7	300	250	200	166.7	150	120	100	83.3	75	60	50	41.7	30	25	20	16.7	15	12.5	10	8.3
	60Hz	600	500	360	300	240	200	180	144	120	100	90	72	60	50	36	30	24	20	18	15	12	10
Applicable gear head	MX9G3B to MX9G180B (ball bearing)	50Hz	0.66 (5.84)	0.78 (6.90)	1.08 (9.56)	1.27 (11.2)	1.57 (13.9)	1.86 (16.5)	2.25 (19.9)	2.74 (24.3)	3.23 (28.6)	3.92 (34.7)	4.41 (39.0)	5.29 (46.8)	6.37 (56.4)	7.94 (70.3)	9.80 (86.7)						
		60Hz	0.55 (4.87)	0.66 (5.84)	0.90 (7.97)	1.08 (9.56)	1.27 (11.2)	1.57 (13.9)	1.76 (15.6)	2.25 (19.9)	2.74 (24.3)	3.23 (28.6)	3.53 (31.2)	4.41 (39.0)	5.29 (46.8)	6.37 (56.4)	8.82 (78.1)	9.80 (86.7)					
Rotational direction		Same as motor rotational direction											Reverse to motor rotational direction										

Permissible torque at output shaft of gear head using decimal gear head

Applicable gear head		Reduction ratio	Speed (r/min)													
Bearing	Decimal gear head		50Hz	7.5	6	5	4.2	3	2.5	2	1.7	1.5	1.3	1	0.8	
MX9G□B (ball bearing) MX9G□M (metal bearing)	MX9G10XB	Permissible torque	N-m (lb-in)	9.80 (86.7)	9.80 (86.7)	9.80 (86.7)	9.80 (86.7)	9.80 (86.7)	9.80 (86.7)	9.80 (86.7)	9.80 (86.7)	9.80 (86.7)	9.80 (86.7)	9.80 (86.7)	9.80 (86.7)	
		Rotational direction		Same as motor rotational direction							Reverse to motor rotational direction					

Connection diagram

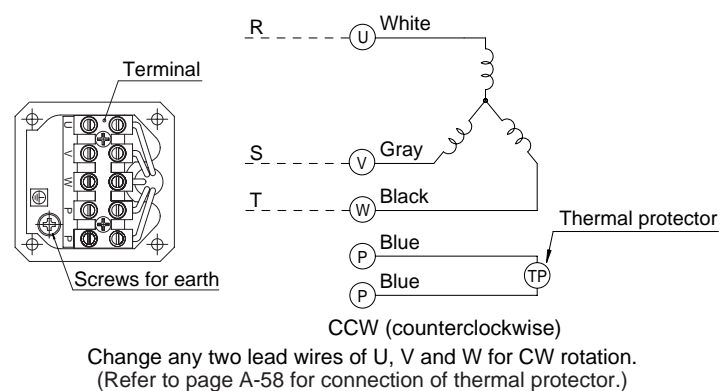

Speed-torque characteristics

M9MX40GK4YG(A) / M9MX40GK4CG(A)

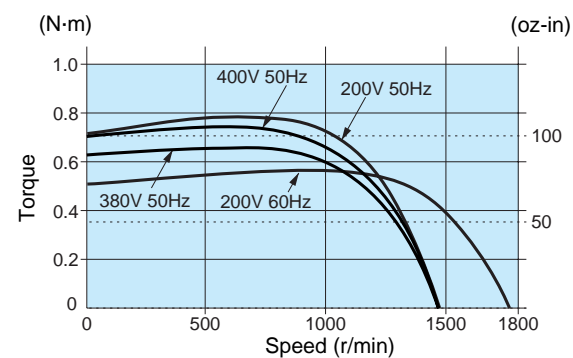

Motor (dimensions)

Scale: 1/3, Unit: mm (inch)

M9MX40GK4YG(A) 4P 40 W 200 V / 220 V / 230 V
M9MX40GK4CG(A) 4P 40 W 380 V / 400 V

Mass 2.8 kg 6.17 lb
Helical gear
Module 0.55
Number of teeth 9

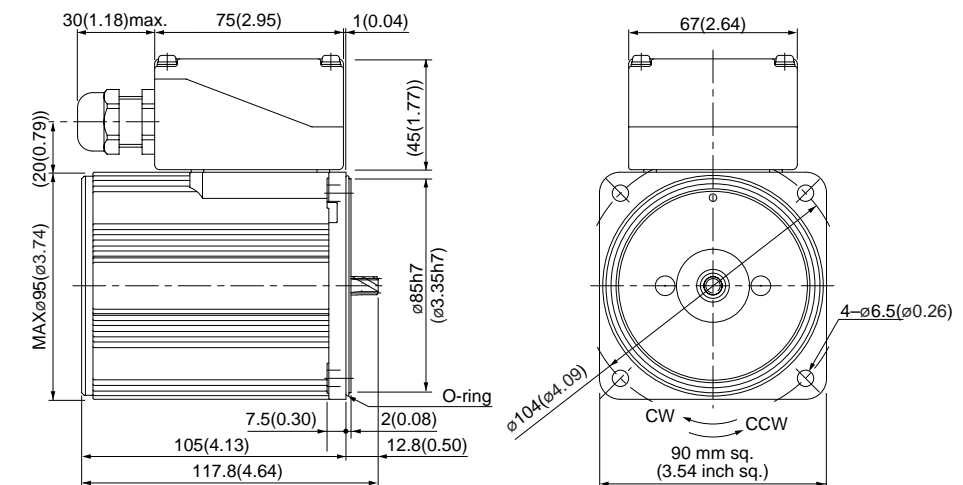

* Diameter of applicable cable to be $\phi 8(\phi 0.31)$ to $\phi 12(\phi 0.47)$.

Gear head (dimensions)

Scale: 1/3, Unit: mm (inch)

MX9G□B (ball bearing) / MX9G□M (metal bearing) Mass 0.8 kg (1.76 lb)

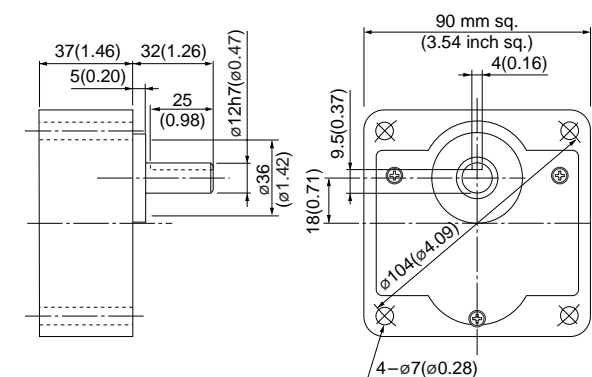

Key and keyway (dimensions) [attachment]

MX9G□B(M)

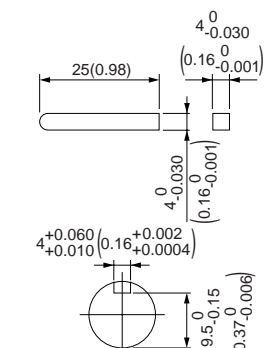

* Please read your User's manual carefully so that you will understand the operation and safety precautions before attempting to operate the system.

(Note) Because the dimensions may be subject to change, also check the determinate dimensions if the gear head is to be used for design.

Induction motor
Reversible motor
3-phase motor
Electromagnetic brake motor
Variable speed induction motor
Variable speed reversible motor
Variable speed electromagnetic brake single-phase motor
Variable speed unit motor
C&B motor
2-pole round shaft motor
Gear head
Gear head -inch (U.S.A.)

Specifications

Size	Motor model No.	Number of pole (P)	Output (W)	Voltage (V)	Frequency (Hz)	Rating (min)	Rating				Starting current (A)	Starting torque N-m (oz-in)
							Input (W)	Current (A)	Speed (r/min)	Torque N-m (oz-in)		
90 mm sq.	M9MZ60GK4Y	4	60	200	50	Cont.	101	0.45	1350	0.42 (59.5)	1.3	1.0 (142)
							96	0.41	1625	0.35 (49.6)	1.2	0.69 (97.7)
				220	50	Cont.	103	0.46	1375	0.41 (58.1)	1.5	1.2 (170)
							98	0.40	1650	0.34 (48.1)	1.3	0.87 (123)

The specifications and wire connections of the round shaft motor are the same as those of the pinion shaft type. For the dimensional outline drawing, refer to page B-165.

Permissible torque at output shaft of gear head

* The speed shown below is a calculated value based on the synchronous rotational speed. Depending on the load, the speed is less than the indicated value by 2 to 20%.

Unit of permissible torque: upper (N·m) / lower (lb·in)

Reduction ratio	Speed (r/min)																							
	3	3.6	5	6	7.5	9	10	12.5	15	18	20	25	30	36	50	60	75	90	100	120	150	180	200	
Speed (r/min)	50Hz	500	416.7	300	250	200	166.7	150	120	100	83.3	75	60	50	41.7	30	25	20	16.7	15	12.5	10	8.3	7.5
	60Hz	600	500	360	300	240	200	180	144	120	100	90	72	60	50	36	30	24	20	18	15	12	10	9
Applicable gear head	MZ9G3B to MZ9G200B (ball bearing / hinge not attached)	50Hz	0.98 (8.7)	1.18 (10.4)	1.57 (13.9)	1.96 (17.3)	2.35 (20.8)	2.94 (26.0)	3.14 (27.8)	3.92 (34.7)	4.70 (41.6)	5.59 (49.5)	6.27 (55.5)	7.55 (66.8)	9.11 (80.6)	11.0 (97.4)	15.2 (135)	17.8 (158)						19.6 (173)
		60Hz	0.78 (6.9)	0.98 (8.7)	1.37 (12.1)	1.57 (13.9)	1.96 (17.3)	2.65 (23.5)	3.33 (29.5)	3.92 (34.7)	4.70 (41.6)	5.29 (46.8)	6.47 (57.3)	7.55 (66.8)	9.11 (80.6)	12.6 (112)	15.2 (135)						19.6 (173)	
Rotational direction	Same as motor rotational direction						Reverse to motor rotational direction						Same as motor rotational direction											

Permissible torque at output shaft of gear head using decimal gear head

Applicable gear head		Reduction ratio	Speed (r/min)												
Bearing	Decimal gear head		50Hz	60Hz	6	5	4.2	3	2.5	2	1.7	1.5	1.3	1	0.8
MZ9G□B (ball bearing / Hinge not attached)	MZ9G10XB	Permissible torque	N-m (lb-in)	19.6 (173)	19.6 (173)	19.6 (173)	19.6 (173)	19.6 (173)	19.6 (173)	19.6 (173)	19.6 (173)	19.6 (173)	19.6 (173)	19.6 (173)	19.6 (173)
			Rotational direction	Reverse to motor rotational direction	Same as motor rotational direction										

Connection diagram

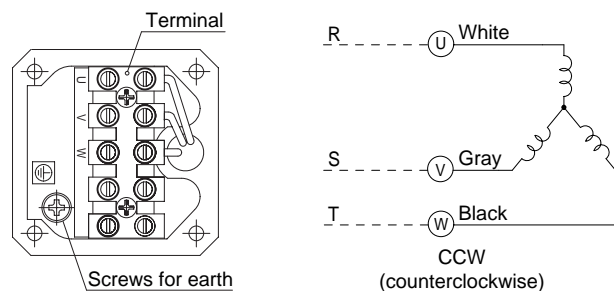

Change any two lead wires of U, V and W for CW rotation.

Speed-torque characteristics

M9MZ60GK4Y

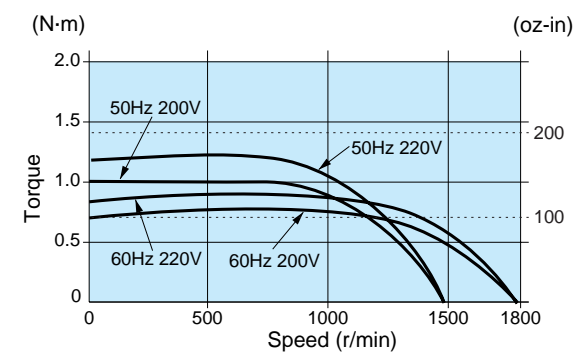

Motor (dimensions)

Scale: 1/4, Unit: mm (inch)

M9MZ60GK4Y 4P 60 W 200 V / 220 V (with fan)

Mass	Helical gear	Module	Number of teeth
3.0 kg 6.61 lb		0.6	9

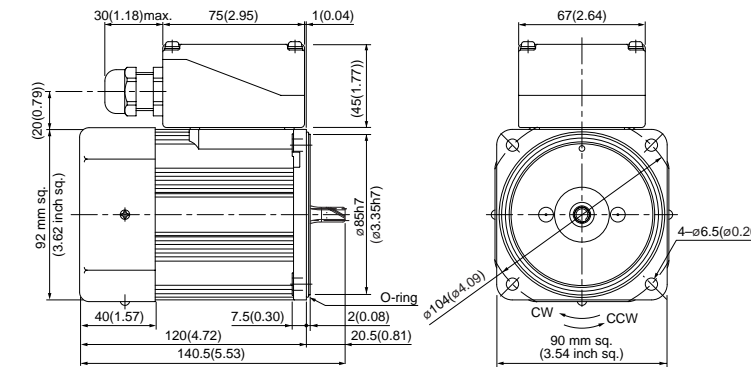

* Diameter of applicable cable to be ø8(ø0.31) to ø12(ø0.47).

Connection diagram

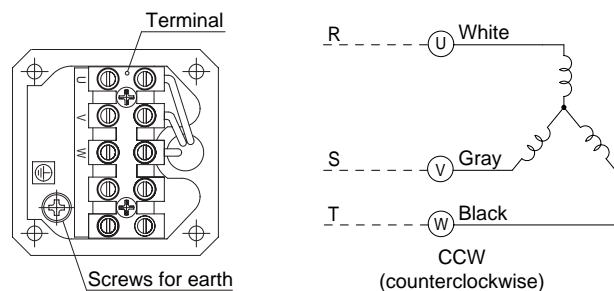

Change any two lead wires of U, V and W for CW rotation.

Speed-torque characteristics

M9MZ60GK4Y

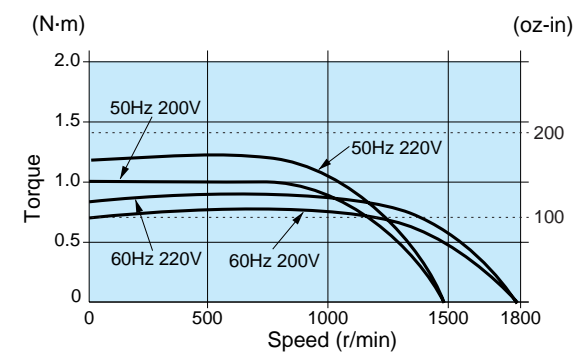

Gear head (dimensions)

Scale: 1/4, Unit: mm (inch)

MZ9G□B (ball bearing / hinge not attached)
Mass 1.4 kg (3.09 lb)

MY9G□B (ball bearing / hinge attached)
Mass 1.4 kg (3.09 lb)

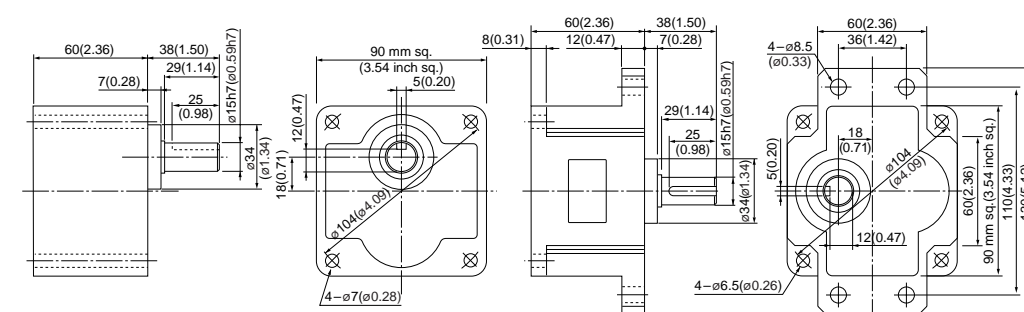

Key and keyway (dimensions) [attachment]

MZ9G□B
MY9G□B

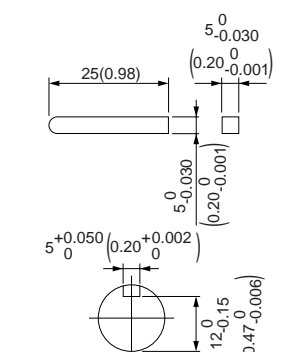

Note) MZ / MY is available for a gear head of either type.

(Note) Because the dimensions may be subject to change, also check the determinate dimensions if the gear head is to be used for design.

3-phase motor (sealed connector)

US CE CCC 90 mm (3.54 inch) sq. 60 W

Specifications

Size	Motor model No.	Number of pole (P)	Output (W)	Voltage (V)	Frequency (Hz)	Rating (min)	Rating				Starting current (A)	Starting torque N-m (oz-in)
							Input (W)	Current (A)	Speed (r/min)	Torque N-m (oz-in)		
90 mm sq.	M9MZ60GK4YG M9MZ60GK4YGA	4	60	200	50	Cont.	101	0.45	1350	0.42 (59.5)	1.3	1.0 (142)
							96	0.41	1625	0.35 (49.6)	1.2	0.69 (97.7)
				220	60		98	0.40	1650	0.35 (49.6)	1.3	0.87 (123)
							98	0.41	1675	0.34 (48.1)	1.4	1.0 (142)
	230	60	Cont.	103	0.22	1325	0.43 (60.9)	0.62	0.88 (125)			
				103	0.22	1325	0.43 (60.9)	0.65	1.0 (142)			
	M9MZ60GK4CG* M9MZ60GK4CGA	4	60	380	50	Cont.	103	0.22	1325	0.43 (60.9)	0.62	0.88 (125)
				400	50		103	0.22	1325	0.43 (60.9)	0.65	1.0 (142)

- * Do not use an inverter to drive 380/400 V motor.
- The specifications and wire connections of the round shaft motor are the same as those of the pinion shaft type. For the dimensional outline drawing, refer to page B-165.
- The models with a motor model number to which "A" is suffixed are not sold or available in Japan.

Permissible torque at output shaft of gear head

* The speed shown below is a calculated value based on the synchronous rotational speed. Depending on the load, the speed is less than the indicated value by 2 to 20%.

Unit of permissible torque: upper (N·m) / lower (lb·in)

Reduction ratio	Speed (r/min)																						
	3	3.6	5	6	7.5	9	10	12.5	15	18	20	25	30	36	50	60	75	90	100	120	150	180	200
50Hz	500	416.7	300	250	200	166.7	150	120	100	83.3	75	60	50	41.7	30	25	20	16.7	15	12.5	10	8.3	7.5
60Hz	600	500	360	300	240	200	180	144	120	100	90	72	60	50	36	30	24	20	18	15	12	10	9
Applicable gear head	MZ9G3B to MZ9G200B (ball bearing / hinge not attached)											MY9G3B to MY9G200B (ball bearing / hinge attached)											
	50Hz	0.98 (8.7)	1.18 (10.4)	1.57 (13.9)	1.96 (17.3)	2.35 (20.8)	2.94 (26.0)	3.14 (27.8)	3.92 (34.7)	4.70 (41.6)	5.59 (49.5)	6.27 (55.5)	7.55 (66.8)	9.11 (80.6)	11.0 (97.4)	15.2 (135)	17.8 (158)						
60Hz	0.78 (6.9)	0.98 (8.7)	1.37 (12.1)	1.57 (13.9)	1.96 (17.3)	2.35 (20.8)	2.65 (23.5)	3.33 (29.5)	3.92 (34.7)	4.70 (41.6)	5.29 (46.8)	6.47 (57.3)	7.55 (66.8)	9.11 (80.6)	12.6 (112)	15.2 (135)							19.6 (173)
Rotational direction	Same as motor rotational direction											Reverse to motor rotational direction											

Permissible torque at output shaft of gear head using decimal gear head

Applicable gear head		Reduction ratio	Speed (r/min)												
Bearing	Decimal gear head		50Hz	60Hz	250	300	360	500	600	750	900	1000	1200	1500	1800
MZ9G□B (ball bearing / hinge not attached)	MZ9G10XB	Permissible torque	N·m (lb-in)	19.6 (173)	19.6 (173)	19.6 (173)	19.6 (173)	19.6 (173)	19.6 (173)	19.6 (173)	19.6 (173)	19.6 (173)	19.6 (173)	19.6 (173)	19.6 (173)
		Rotational direction	Reverse to motor rotational direction	Same as motor rotational direction											

Connection diagram

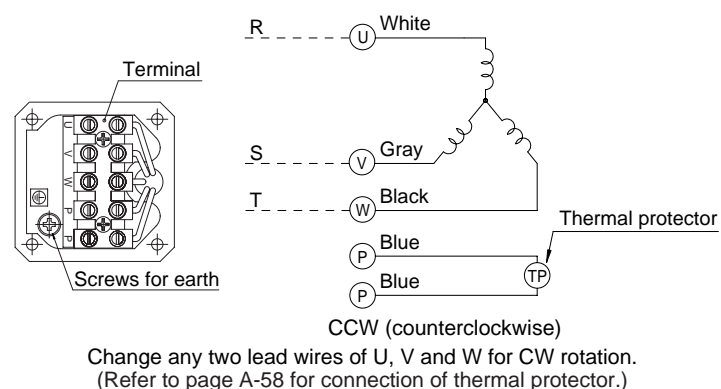

Speed-torque characteristics

M9MZ60GK4YG(A) / M9MZ60GK4CG(A)

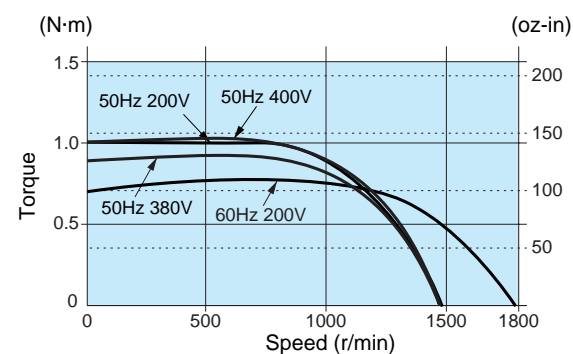

Motor (dimensions)

Scale: 1/4, Unit: mm (inch)

M9MZ60GK4YG(A) 4P 60 W 200 V / 220 V / 230 V (with fan)
M9MZ60GK4CG(A) 4P 60 W 380 V / 400 V (with fan)

Mass 3.0 kg 6.61 lb
Helical gear
Module 0.6
Number of teeth 9

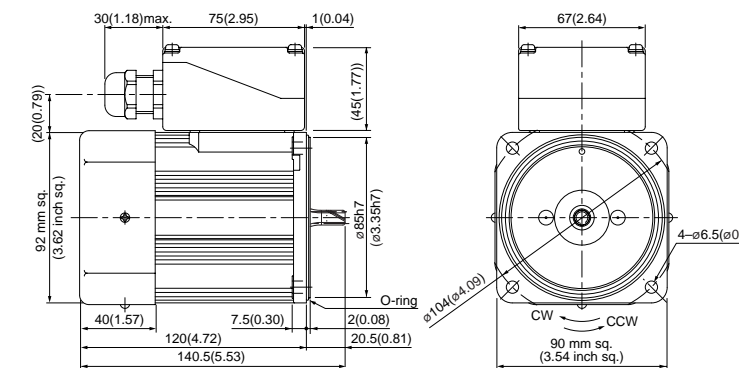

* Diameter of applicable cable to be ø8(ø0.31) to ø12(ø0.47).

Gear head (dimensions)

Scale: 1/4, Unit: mm (inch)

MZ9G□B (ball bearing / hinge not attached)
Mass 1.4 kg (3.09 lb)

MY9G□B (ball bearing / hinge attached)
Mass 1.4 kg (3.09 lb)

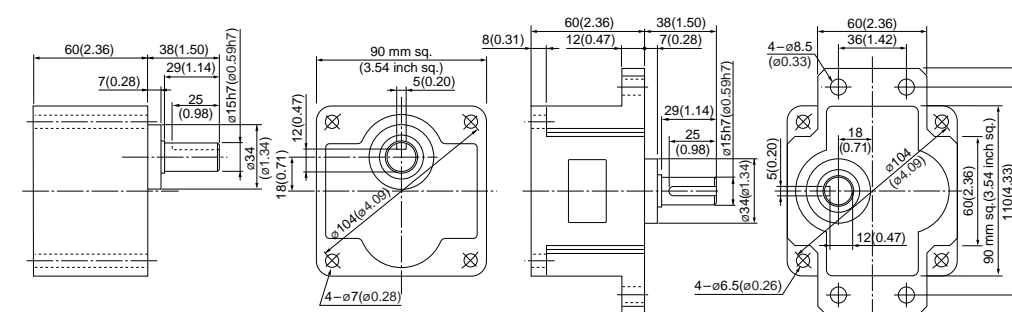

Note) MZ / MY is available for a gear head of either type.

(Note) Because the dimensions may be subject to change, also check the determinate dimensions if the gear head is to be used for design.

Key and keyway (dimensions) [attachment]

MZ9G□B
MY9G□B

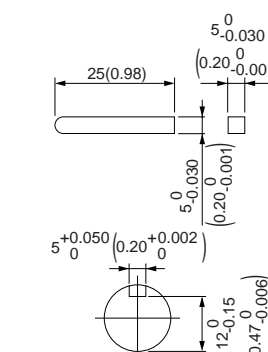

Specifications

Size	Motor model No.	Number of pole (P)	Output (W)	Voltage (V)	Frequency (Hz)	Rating (min)	Rating				Starting current (A)	Starting torque N-m (oz-in)
							Input (W)	Current (A)	Speed (r/min)	Torque N-m (oz-in)		
90 mm sq.	M9MZ90GK4Y	4	90	200	50	Cont.	141	0.62	1350	0.63 (89.2)	2.0	1.6 (227)
							137	0.56	1625	0.53 (75.1)	1.8	1.1 (156)
				220	50	Cont.	143	0.65	1400	0.62 (87.8)	2.2	2.0 (283)
							137	0.56	1650	0.52 (73.6)	2.0	1.4 (198)

The specifications and wire connections of the round shaft motor are the same as those of the pinion shaft type. For the dimensional outline drawing, refer to page B-165.

Permissible torque at output shaft of gear head

* The speed shown below is a calculated value based on the synchronous rotational speed. Depending on the load, the speed is less than the indicated value by 2 to 20%.

Unit of permissible torque: upper (N·m) / lower (lb·in)

Reduction ratio	Unit of permissible torque: upper (N·m) / lower (lb·in)																							
	3	3.6	5	6	7.5	9	10	12.5	15	18	20	25	30	36	50	60	75	90	100	120	150	180	200	
Speed (r/min)	50Hz	500	416.7	300	250	200	166.7	150	120	100	83.3	75	60	50	41.7	30	25	20	16.7	15	12.5	10	8.3	7.5
	60Hz	600	500	360	300	240	200	180	144	120	100	90	72	60	50	36	30	24	20	18	15	12	10	9
Applicable gear head	MZ9G3B to MZ9G200B (ball bearing / hinge not attached)	50Hz	1.37 (12.1)	1.67 (14.8)	2.25 (19.9)	2.74 (24.3)	3.43 (30.4)	4.12 (36.5)	4.51 (39.9)	5.68 (50.3)	6.76 (59.8)	8.04 (71.2)	9.02 (79.8)	10.9 (96.5)	13.0 (115)	15.7 (139)	19.6 (173)							
	MY9G3B to MY9G200B (ball bearing / hinge attached)	60Hz	1.18 (10.4)	1.37 (12.1)	1.86 (16.5)	2.25 (19.9)	2.84 (25.1)	3.43 (30.4)	3.72 (32.9)	4.70 (41.6)	5.68 (50.3)	6.76 (59.8)	7.55 (66.8)	9.21 (81.5)	10.9 (96.5)	13.0 (115)	18.3 (162)							
Rotational direction	Same as motor rotational direction						Reverse to motor rotational direction						Same as motor rotational direction											

Permissible torque at output shaft of gear head using decimal gear head

Applicable gear head		Reduction ratio	Reduction ratio											
Bearing	Decimal gear head		Speed (r/min)	250	300	360	500	600	750	900	1000	1200	1500	1800
MZ9G□B (ball bearing / hinge not attached)	MZ9G10XB	50Hz	6	5	4.2	3	2.5	2	1.7	1.5	1.3	1	0.8	
		60Hz	7.2	6	5	3.6	3	2.4	2	1.8	1.5	1.2	1	
MY9G□B (ball bearing / hinge attached)	MZ9G10XB	Permissible torque	N-m (lb-in)	19.6 (173)	19.6 (173)	19.6 (173)	19.6 (173)	19.6 (173)	19.6 (173)	19.6 (173)	19.6 (173)	19.6 (173)	19.6 (173)	
		Rotational direction	Reverse to motor rotational direction			Same as motor rotational direction								

Connection diagram

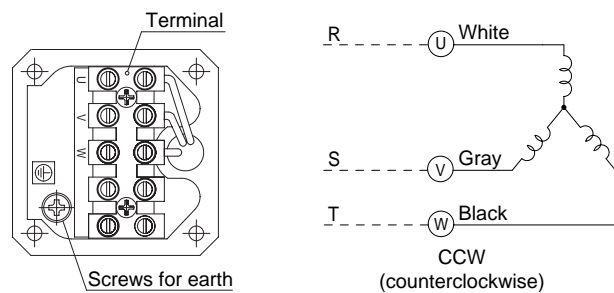

Change any two lead wires of U, V and W for CW rotation.

Speed-torque characteristics

M9MZ90GK4Y

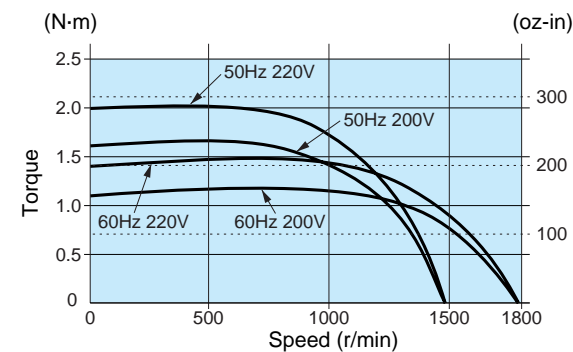

Motor (dimensions)

M9MZ90GK4Y 4P 90 W 200 V / 220 V (with fan)

Scale: 1/4, Unit: mm (inch)

Mass	Helical gear	Module	Number of teeth
3.3 kg 7.28 lb		0.6	9

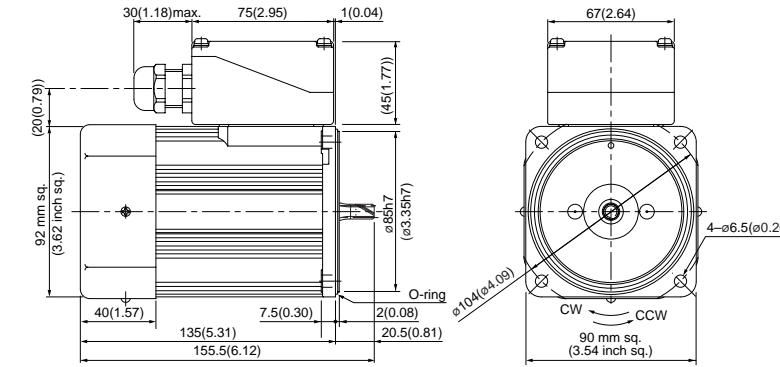

* Diameter of applicable cable to be $\phi 8(\phi 0.31)$ to $\phi 12(\phi 0.47)$.

Connection diagram

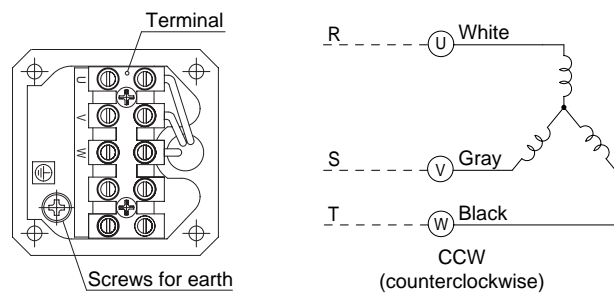

Change any two lead wires of U, V and W for CW rotation.

Speed-torque characteristics

M9MZ90GK4Y

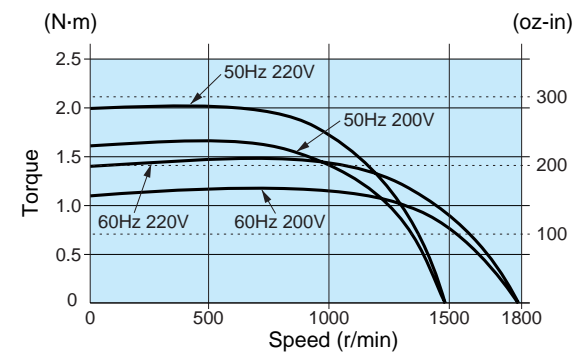

Gear head (dimensions)

Scale: 1/4, Unit: mm (inch)

MZ9G□B (ball bearing / hinge not attached)
Mass 1.4 kg (3.09 lb)

MY9G□B (ball bearing / hinge attached)
Mass 1.4 kg (3.09 lb)

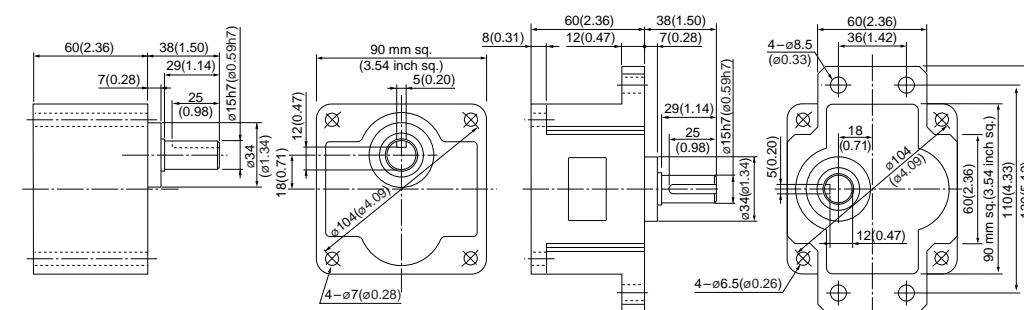

Key and keyway (dimensions) [attachment]

MZ9G□B
MY9G□B

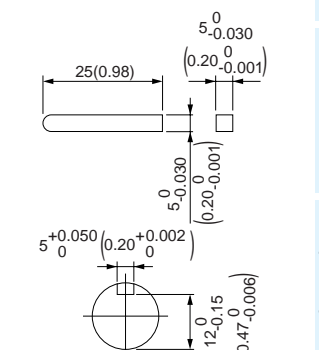

Note) MZ / MY is available for a gear head of either type.

(Note) Because the dimensions may be subject to change, also check the determinate dimensions if the gear head is to be used for design.

3-phase motor (sealed connector)

US CE CCC 90 mm (3.54 inch) sq. 90 W

Specifications

Size	Motor model No.	Number of pole (P)	Output (W)	Voltage (V)	Frequency (Hz)	Rating (min)	Rating				Starting current (A)	Starting torque N-m (oz-in)
							Input (W)	Current (A)	Speed (r/min)	Torque N-m (oz-in)		
90 mm sq.	M9MZ90GK4YG M9MZ90GK4YGA	4	90	200	50	Cont.	142	0.62	1350	0.63 (89.2)	2.0	1.6 (227)
							138	0.56	1625	0.53 (75.1)	1.8	1.1 (156)
				220	60		137	0.56	1650	0.52 (73.6)	2.0	1.4 (198)
				230	60		137	0.58	1675	0.51 (72.2)	2.1	1.6 (227)
	M9MZ90GK4CG * M9MZ90GK4CGA	4	90	380	50	Cont.	144	0.31	1325	0.65 (92.0)	1.0	1.4 (198)
							144	0.31	1350	0.64 (90.6)	1.0	1.6 (227)

- * Do not use an inverter to drive 380/400 V motor.
- The specifications and wire connections of the round shaft motor are the same as those of the pinion shaft type. For the dimensional outline drawing, refer to page B-165.
- The models with a motor model number to which "A" is suffixed are not sold or available in Japan.

Permissible torque at output shaft of gear head

* The speed shown below is a calculated value based on the synchronous rotational speed. Depending on the load, the speed is less than the indicated value by 2 to 20%.

Unit of permissible torque: upper (N·m) / lower (lb-in)

Reduction ratio	Speed (r/min)																							
	3	3.6	5	6	7.5	9	10	12.5	15	18	20	25	30	36	50	60	75	90	100	120	150	180	200	
Speed (r/min)	50Hz	500	416.7	300	250	200	166.7	150	120	100	83.3	75	60	50	41.7	30	25	20	16.7	15	12.5	10	8.3	7.5
	60Hz	600	500	360	300	240	200	180	144	120	100	90	72	60	50	36	30	24	20	18	15	12	10	9
Applicable gear head	MZ9G3B to MZ9G200B (ball bearing / hinge not attached)	1.37	1.67	2.25	2.74	3.43	4.12	4.51	5.68	6.76	8.04	9.02	10.9	13.0	15.7	19.6								19.6 (173)
	MY9G3B to MY9G200B (ball bearing / hinge attached)	1.18	1.37	1.86	2.25	2.84	3.43	3.72	4.70	5.68	6.76	7.55	9.21	10.9	13.0	18.3								19.6 (173)
Rotational direction	Same as motor rotational direction											Reverse to motor rotational direction				Same as motor rotational direction								

Permissible torque at output shaft of gear head using decimal gear head

Applicable gear head		Reduction ratio	Speed (r/min)												
Bearing	Decimal gear head		50Hz	60Hz	250	300	360	500	600	750	900	1000	1200	1500	1800
MZ9G□B (ball bearing / hinge not attached)	MZ9G10XB	Permissible torque	N·m (lb-in)	19.6 (173)	19.6 (173)	19.6 (173)	19.6 (173)	19.6 (173)	19.6 (173)	19.6 (173)	19.6 (173)	19.6 (173)	19.6 (173)	19.6 (173)	19.6 (173)
		Rotational direction		Reverse to motor rotational direction	Same as motor rotational direction										

Connection diagram

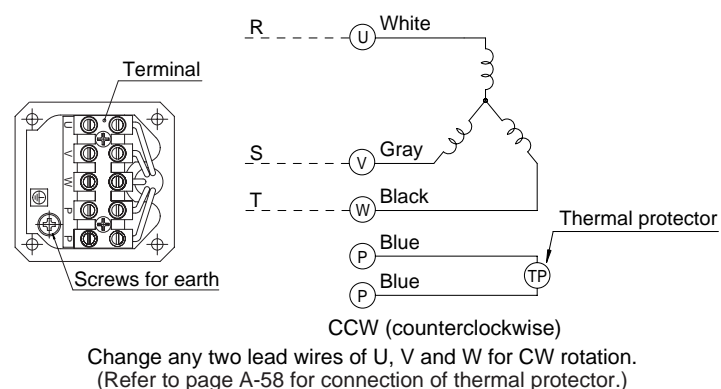

Speed-torque characteristics

M9MZ90GK4YG(A) / M9MZ90GK4CG(A)

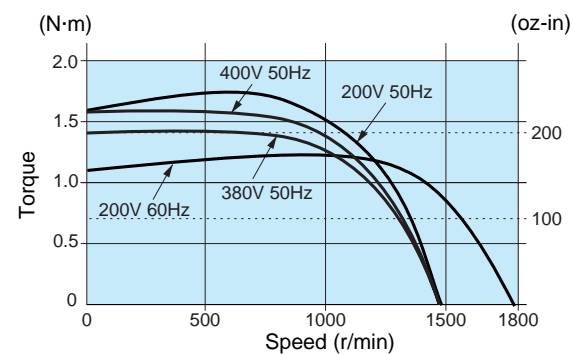

Motor (dimensions)

Scale: 1/4, Unit: mm (inch)

M9MZ90GK4YG(A) 4P 90 W 200 V / 220 V / 230 V (with fan)
M9MZ90GK4CG(A) 4P 90 W 380 V / 400 V (with fan)

Mass 3.3 kg 7.28 lb
Helical gear
Module 0.6
Number of teeth 9

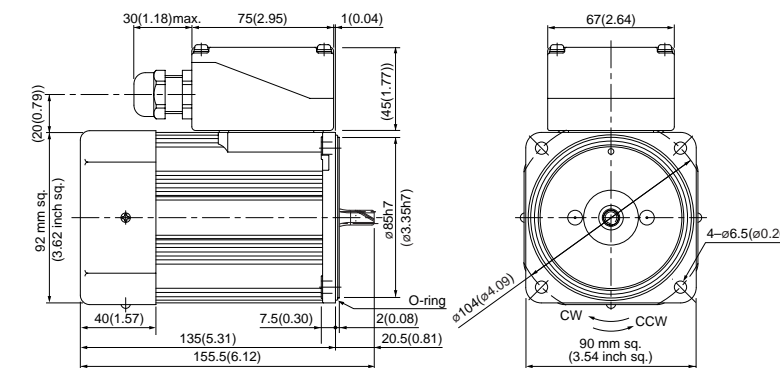

* Diameter of applicable cable to be $\phi 8(\phi 0.31)$ to $\phi 12(\phi 0.47)$.

* Please read your User's manual carefully so that you will understand the operation and safety precautions before attempting to operate the system.

Gear head (dimensions)

Scale: 1/4, Unit: mm (inch)

MZ9G□B (ball bearing / hinge not attached)
Mass 1.4 kg (3.09 lb)

MY9G□B (ball bearing / hinge attached)
Mass 1.4 kg (3.09 lb)

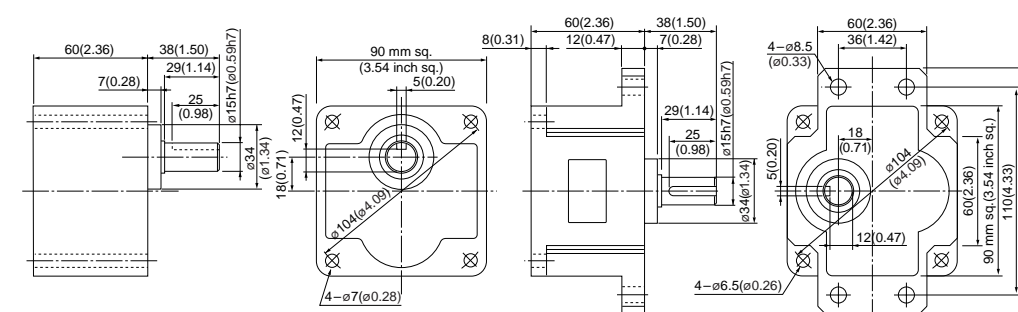

Key and keyway (dimensions) [attachment]

MZ9G□B
MY9G□B

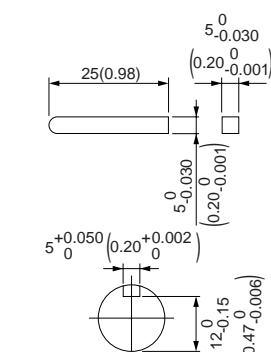

Note) MZ / MY is available for a gear head of either type.

(Note) Because the dimensions may be subject to change, also check the determinate dimensions if the gear head is to be used for design.

3-phase motor (leadwire)

Gear head combination dimensions
Scale: 1/4, Unit: mm (inch)

80 mm sq. (3.15 inch sq.) 25 W

M8MX25G4Y + MX8G□B(M)
M8MX25G4YG(A) + MX8G□B(M)

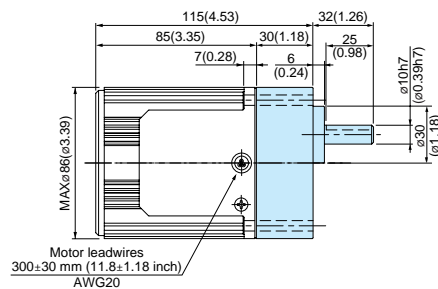

90 mm sq. (3.54 inch sq.) 40 W

M9MX40G4Y + MX9G□B(M)
M9MX40G4YG(A) + MX9G□B(M)

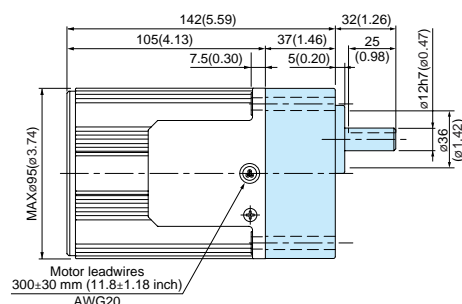

90 mm sq. (3.54 inch sq.) 60 W

M9MZ60G4Y + MZ9G□B (MY9G□B)
M9MZ60G4YG(A) + MZ9G□B (MY9G□B)

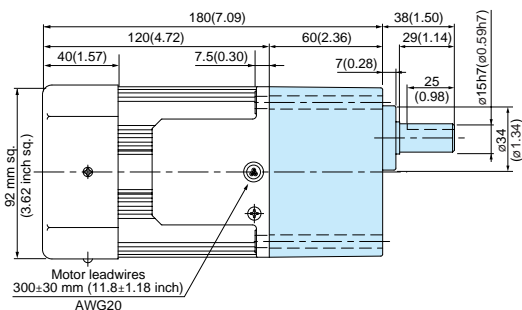

* Refer to page B-444 for high torque gear head.

90 mm sq. (3.54 inch sq.) 90 W

M9MZ90G4Y + MY9G□B (MZ9G□B)
M9MZ90G4YG(A) + MY9G□B (MZ9G□B)

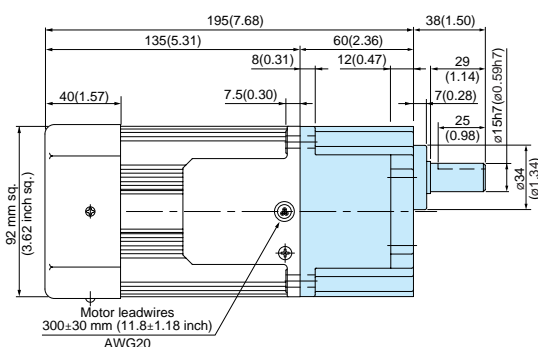

* Refer to page B-444 for high torque gear head.

3-phase motor (sealed connector)

Gear head combination dimensions
Scale: 1/4, Unit: mm (inch)

80 mm sq. (3.15 inch sq.) 25 W

M8MX25GK4Y + MX8G□B(M)
M8MX25GK4YG(A) + MX8G□B(M)
M8MX25GK4CG(A) + MX8G□B(M)

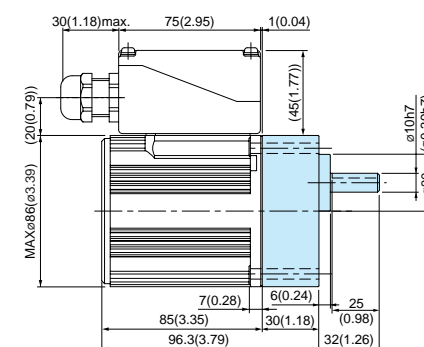

* Diameter of applicable cabtyre cable to be ø8(ø0.31) to ø12(ø0.47).

90 mm sq. (3.54 inch sq.) 40 W

M9MX40GK4Y + MX9G□B(M)
M9MX40GK4YG(A) + MX9G□B(M)
M9MX40GK4CG(A) + MX9G□B(M)

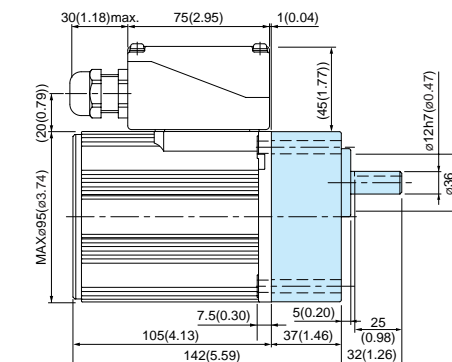

* Diameter of applicable cabtyre cable to be ø8(ø0.31) to ø12(ø0.47).

90 mm sq. (3.54 inch sq.) 60 W

M9MZ60GK4Y + MZ9G□B (MY9G□B)
M9MZ60GK4YG(A) + MZ9G□B (MY9G□B)
M9MZ60GK4CG(A) + MZ9G□B (MY9G□B)

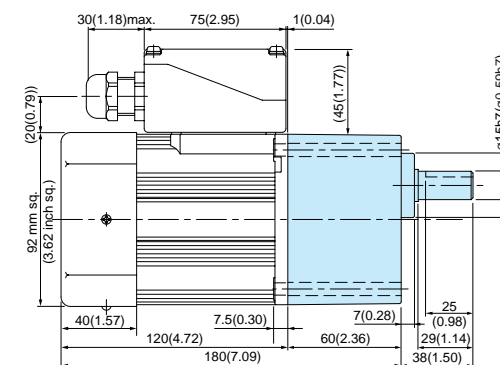

* Diameter of applicable cabtyre cable to be ø8(ø0.31) to ø12(ø0.47).

* Refer to page B-444 for high torque gear head.

90 mm sq. (3.54 inch sq.) 90 W

M9MZ90GK4Y + MY9G□B (MZ9G□B)
M9MZ90GK4YG(A) + MY9G□B (MZ9G□B)
M9MZ90GK4CG(A) + MY9G□B (MZ9G□B)

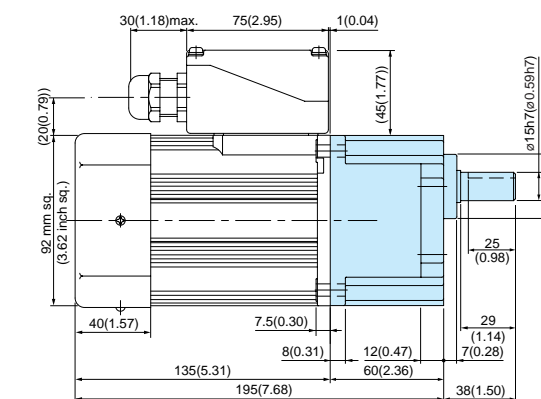

* Diameter of applicable cabtyre cable to be ø8(ø0.31) to ø12(ø0.47).

* Refer to page B-444 for high torque gear head.

3-phase motor (4-pole round shaft / leadwire)

Dimensions
Scale: 1/4, Unit: mm (inch)

80 mm sq. (3.15 inch sq.) 25 W Mass 1.5 kg (3.31 lb)
M8MX25S4YS
M8MX25S4YG(A)

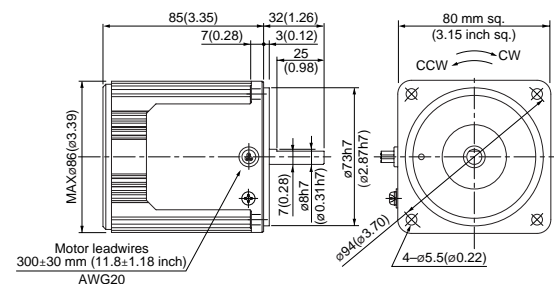

90 mm sq. (3.54 inch sq.) 40 W Mass 2.4 kg (5.29 lb)
M9MX40S4YS
M9MX40S4YG(A)

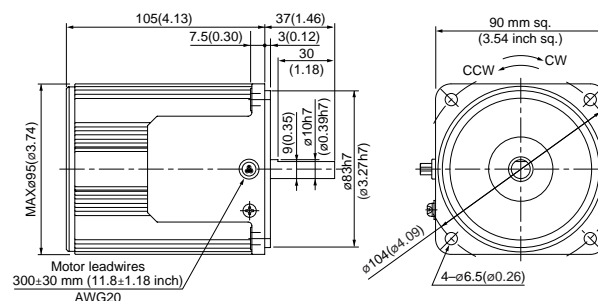

90 mm sq. (3.54 inch sq.) 60 W Mass 2.7 kg (5.95 lb)
M9MZ60S4YS (with fan)
M9MZ60S4YG(A) (with fan)

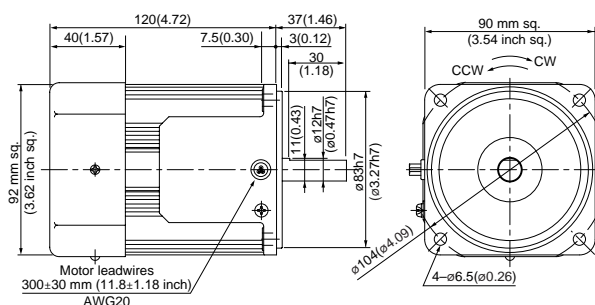

90 mm sq. (3.54 inch sq.) 90 W Mass 3.2 kg (7.05 lb)
M9MZ90S4YS (with fan)
M9MZ90S4YG(A) (with fan)

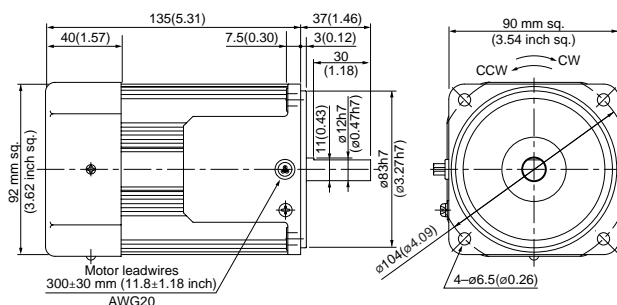

3-phase motor (4-pole round shaft / sealed connector)

Dimensions
Scale: 1/4, Unit: mm (inch)

80 mm sq. (3.15 inch sq.) 25 W Mass 1.8 kg (3.97 lb)
M8MX25SK4YS
M8MX25SK4YG(A)
M8MX25SK4CG(A)

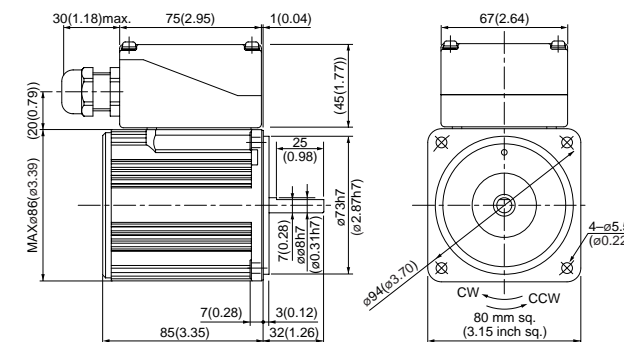

* Diameter of applicable cabtyre cable to be $\varnothing 8(\varnothing 0.31)$ to $\varnothing 12(\varnothing 0.47)$.

90 mm sq. (3.54 inch sq.) 40 W Mass 2.8 kg (6.17 lb)
M9MX40SK4YS
M9MX40SK4YG(A)
M9MX40SK4CG(A)

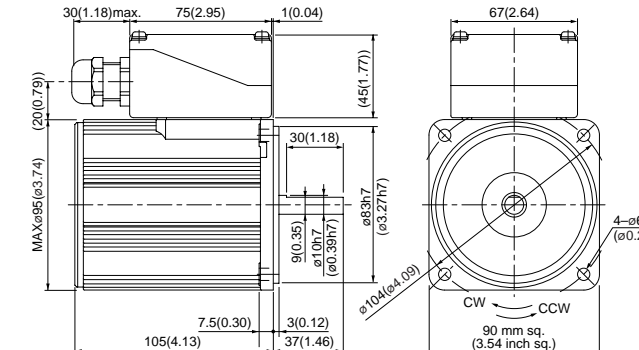

* Diameter of applicable cabtyre cable to be $\varnothing 8(\varnothing 0.31)$ to $\varnothing 12(\varnothing 0.47)$.

90 mm sq. (3.54 inch sq.) 60 W Mass 3.0 kg (6.61 lb)
M9MZ60SK4YS (with fan)
M9MZ60SK4YG(A) (with fan)
M9MZ60SK4CG(A) (with fan)

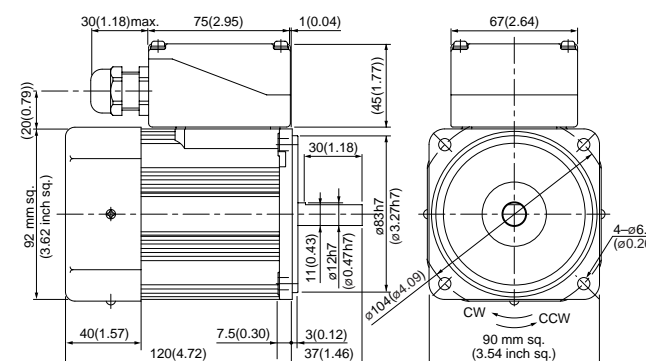

* Diameter of applicable cabtyre cable to be $\varnothing 8(\varnothing 0.31)$ to $\varnothing 12(\varnothing 0.47)$.

90 mm sq. (3.54 inch sq.) 90 W Mass 3.3 kg (7.28 lb)
M9MZ90SK4YS (with fan)
M9MZ90SK4YG(A) (with fan)
M9MZ90SK4CG(A) (with fan)

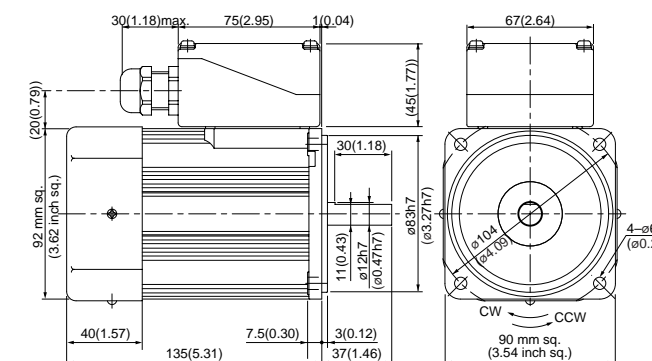

* Diameter of applicable cabtyre cable to be $\varnothing 8(\varnothing 0.31)$ to $\varnothing 12(\varnothing 0.47)$.

200 V/220 V/230 V round shaft motors with a sealed connector (with a terminal box) are covered by the Electrical Appliance and Material Safety Law. The indications on their nameplate are based on this law.

