

⚠ Safety Precautions

- Important Notes on exporting this product or equipment containing this product;
If the end-user or application of this product is related to military affairs or weapons, its export may be controlled by "Foreign Exchange and Foreign Trade Control Law" of Japan where export license will be required before product can be exported from Japan.
- This product is designed and manufactured for use in General Purpose Industrial Equipment and it is not intended to be used in equipment or system that may cause personal injury or death.
- All servicing such as installation, wiring, operation, maintenance and etc., should be performed by qualified personnel only.
- Tighten mounting screws with an adequate torque by taking into consideration strength of the screws and the characteristics of material to which the product will be mounted. Over tightening can damage the screw and/or material; under tightening can result in loosening.
- Install safety equipment to prevent serious accidents or loss that is expected in case of failure of this product.
- Consult us before using this product under such special conditions and environments as nuclear energy control, aerospace, transportation, medical equipment, various safety equipments or equipments which require a lesser air contamination.
- We have been making the best effort to ensure the highest quality of our products, however, some applications with exceptionally large external noise disturbance and static electricity, or failure in input power, wiring and components may result in unexpected action. It is highly recommended that you make a fail-safe design and secure the safety in the operative range.
- If the motor shaft is not electrically grounded, it may cause an electrolytic corrosion to the bearing, depending on the condition of the machine and its mounting environment, and may result in the bearing noise. Checking and verification by customer is required.
- Failure of this product depending on its content may generate smoke of about one cigarette. Take this into consideration when the application of the machine is clean room related.
- Please be careful when using the product in an environment with high concentrations of sulfur or sulfuric gases, as sulfuration can lead to disconnection from the chip resistor or a poor contact connection.
- Do not input a supply voltage which significantly exceeds the rated range to the power supply of this product. Failure to heed this caution may lead to damage of the internal parts, causing smoke and/or fire and other troubles.
- The user is responsible for matching between machine and components in terms of configuration, dimensions, life expectancy, characteristics, when installing the machine or changing specification of the machine. The user is also responsible for complying with applicable laws and regulations.
- Manufacturer's warranty will be invalid if the product has been used outside its stated specifications.
- Component parts are subject to minor change to improve performance.
- Read and observe the instruction manual to ensure correct use of the product.

Repair Consult to the dealer from whom you have purchased this product for details of repair work.
When the product is incorporated to the machine you have purchased, consult to the machine manufacturer or its dealer.

URL Electronic data of this product (Instruction Manual, CAD data) can be downloaded from the following web site;
industrial.panasonic.com/ac/e/

● Contact to : _____

**Panasonic Industry Co., Ltd.,
Industrial Device Business Division**
1-1 Morofuku 7-chome, Daito, Osaka 574-0044, Japan
©Panasonic Industry Co., Ltd.2022
The contents of this catalog apply to the products as of April 2022.

Compact AC Geared Motor

COMPACT AC GEARED MOTOR

COMPACT AC GEARED MOTOR



Gear Head

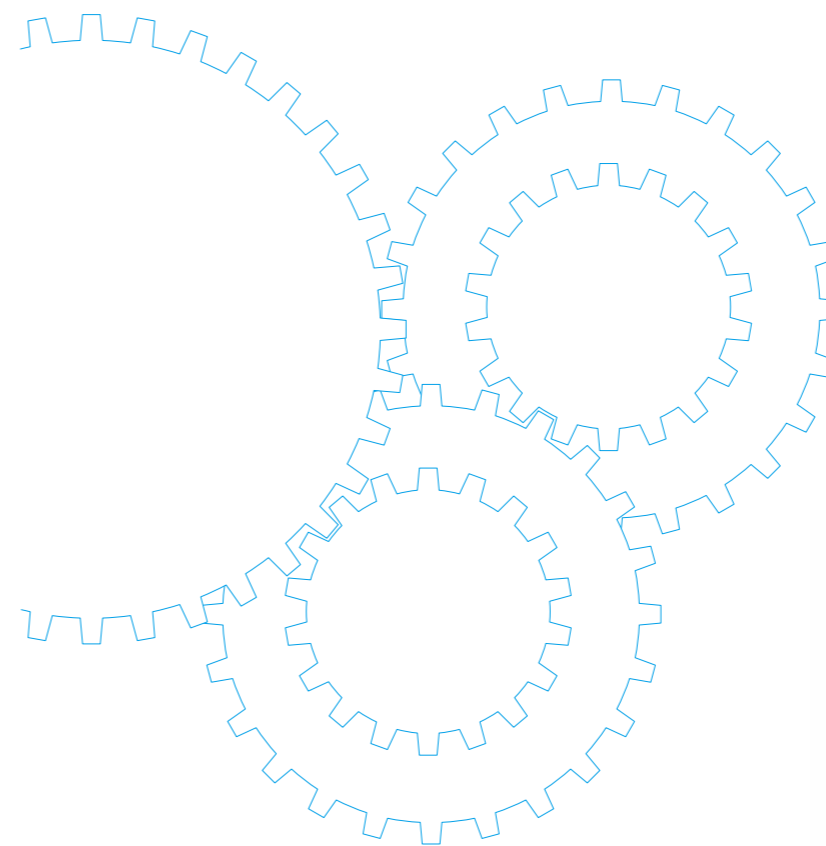

Contents

• Gear head Overview	B-432
• Model list	B-440
• High torque gear head	B-444
• Right-angle gear head	B-446
• Decimal gear head	B-448

Outline of gear head

Features

- Various types of gear heads are available.
- The X type is available in a metal bearing model and or a ball bearing type.
- The P type (90 mm sq. only) is high torque type: its maximum permissible shaft torque is 29.4 N·m (300 kgf·cm)
- 22 reduction ratios from 1/3 to 1/180 are available for the X type; 23 reduction ratios from 1/3 to 1/200 are available for the Y and Z types.
- When the decimal gear head (reduction ratio: 1/10) is used, a reduction ratio of up to 1/1800 (1/2000 for the Y and Z types) can be attained.
- The X type and Z type of 90 mm sq. are available in right-angle type.
- Gear heads dedicated to C&B motors are available. The gear heads will withstand 2 million start and stop cycles.

For allowable gear head permissible torque, see C&B motor (p. B-342).

Gear type

- A : 3 W or smaller / Hinge not attached (42 mm sq.)
- X : 40 W or smaller / Hinge not attached
- Z : 60 W or larger / Hinge not attached
- Y : 60 W or larger / Hinge attached
- R : 60 W or larger, High torque type / Hinge not attached
- P : 60 W or larger, High torque type / Hinge attached

• Hinge not attached

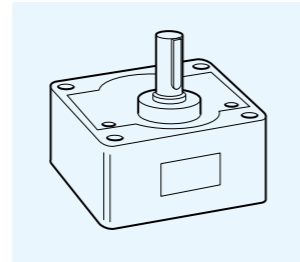

• Hinge attached

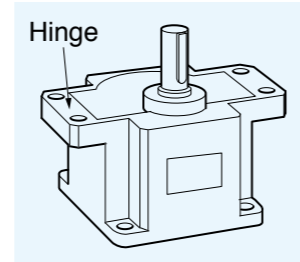

• Gear type and reduction ratio list

Gear type	Motor capacity	Hinge	Reduction ratio																						
			1/3	1/3.6	1/5	1/6	1/7.5	1/9	1/10	1/12.5	1/15	1/18	1/20	1/25	1/30	1/36	1/50	1/60	1/75	1/90	1/100	1/120	1/150	1/180	1/200
A	3 W or smaller	Not attached	○	○	○	○	○	○	○	○	○	○	○	○	○	○	○	○	○	○	○	○	○	○	○
X	40 W or smaller	Not attached	○	○	○	○	○	○	○	○	○	○	○	○	○	○	○	○	○	○	○	○	○	○	○
Y	60 W, 90 W	attached	○	○	○	○	○	○	○	○	○	○	○	○	○	○	○	○	○	○	○	○	○	○	○
Z		Not attached	○	○	○	○	○	○	○	○	○	○	○	○	○	○	○	○	○	○	○	○	○	○	○
P		attached	○	○	○	○	○	○	○	○	○	○	○	○	○	○	○	○	○	○	○	○	○	○	○
R		Not attached	○	○	○	○	○	○	○	○	○	○	○	○	○	○	○	○	○	○	○	○	○	○	○
Right-angle	X	40 W or smaller	○	○	○	○	○	○	○	○	○	○	○	○	○	○	○	○	○	○	○	○	○	○	○
	Z	60 W, 90 W	○	○	○	○	○	○	○	○	○	○	○	○	○	○	○	○	○	○	○	○	○	○	○
C&B	X	40 W or smaller	○	○	○	○	○	○	○	○	○	○	○	○	○	○	○	○	○	○	○	○	○	○	○
	Y	60 W or larger	○	○	○	○	○	○	○	○	○	○	○	○	○	○	○	○	○	○	○	○	○	○	○

• Gear type and reduction ratio list (decimal gear head used)

Gear type	Motor capacity	Hinge	Reduction ratio																		
			1/200	1/250	1/300	1/360	1/500	1/600	1/750	1/900	1/1000	1/1200	1/1500	1/1800	1/2000						
X	40 W or smaller	Not attached	○	○	○	○	○	○	○	○	○	○	○	○	○	○	○	○	○	○	○
Y, P	60 W, 90 W	attached	○	○	○	○	○	○	○	○	○	○	○	○	○	○	○	○	○	○	○
Z, R		Not attached	○	○	○	○	○	○	○	○	○	○	○	○	○	○	○	○	○	○	○
Right-angle	X	40 W or smaller	○	○	○	○	○	○	○	○	○	○	○	○	○	○	○	○	○	○	○
	Z	60 W, 90 W	○	○	○	○	○	○	○	○	○	○	○	○	○	○	○	○	○	○	○

Coding system

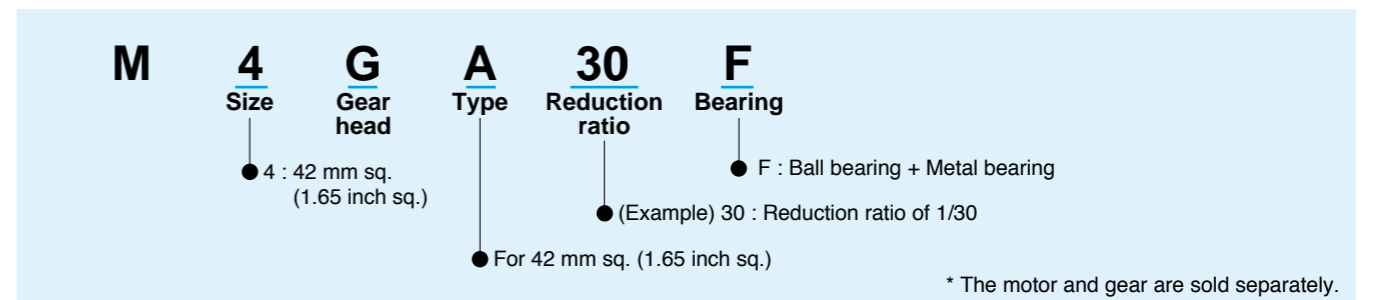
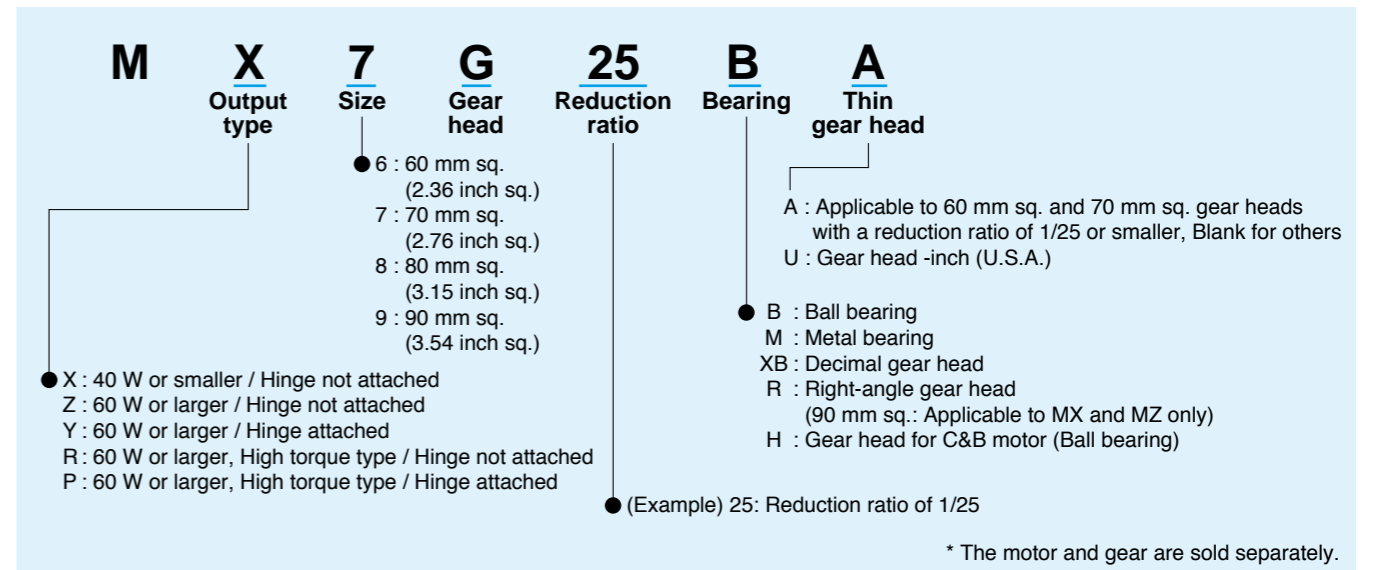

Calculation of torque at output shaft of gear head

• Standard gear head only

$$N_G = \frac{N_M}{i}$$

$$T_G = T_M \times i \times \eta$$

N_G : Speed of gear head (r/min)

N_M : Motor speed (r/min)

i : Reduction ratio of gear head

T_G : Output torque of gear head (N·m)

T_M : Motor torque (N·m)

η : Gear head efficiency

• With decimal gear head

$$N_G = \frac{N_M}{i \times i_D}$$

$$T_G = T_M \times i \times i_D \times \eta \times \eta_D$$

N_G : Speed of gear head (r/min)

N_M : Motor speed (r/min)

i : Reduction ratio of gear head

T_G : Output torque of gear head (N·m)

T_M : Motor torque (N·m)

η : Gear head efficiency

i_D : Reduction ratio of decimal gear head

η_D : Decimal gear head efficiency

* In the case of the variable speed motor, regard the serviceability limit torque as the motor torque.

Outline of gear head

Maximum permissible torque

There is a limit to the strength of a gear due to its material and construction. The usable load torque determined based on this limit is called permissible torque. As can be seen from the above-mentioned formula, the load becomes larger when the reduction ratio is increased. If the gear head is used with the load exceeding the permissible torque, its life expectancy will be shortened significantly. Refer to the following graph and the permissible torque for each model and use the gear head at an appropriate load.

• Maximum permissible torque

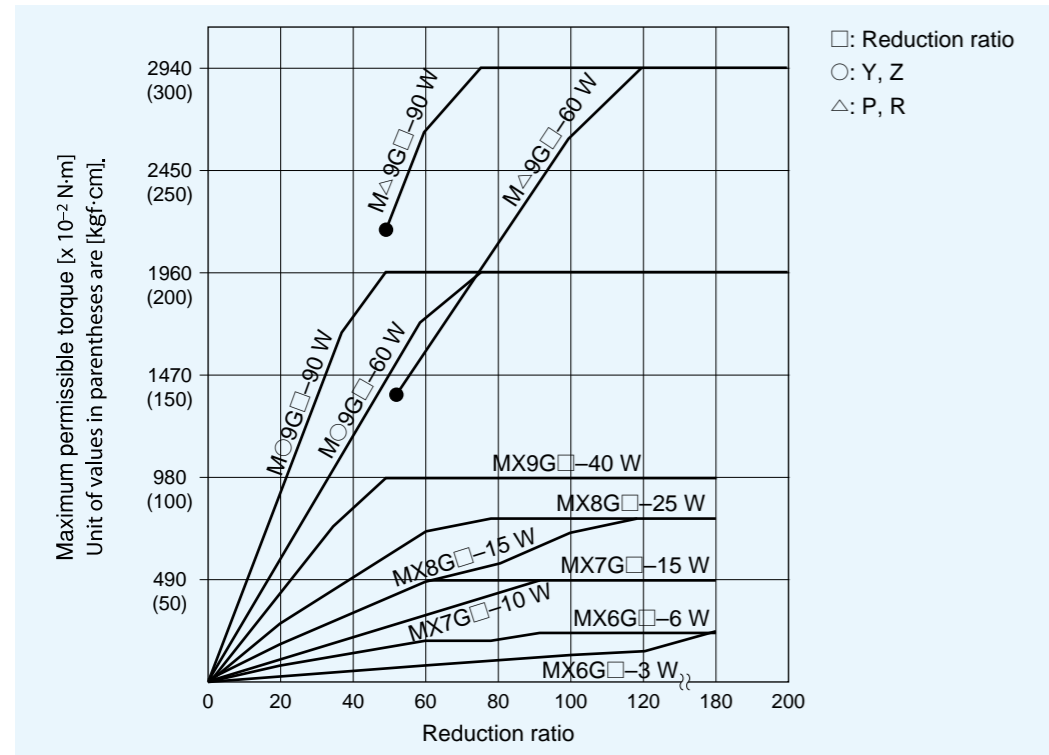

• Maximum permissible torque (Gear head for C&B motor)

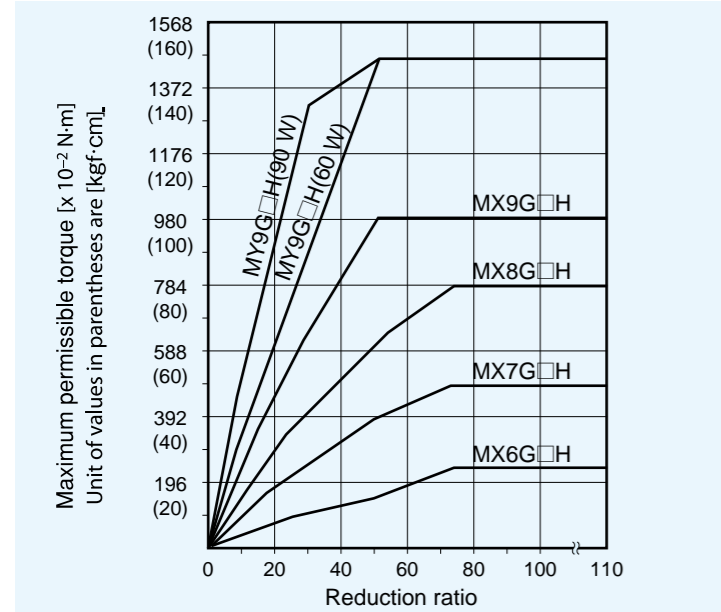

Nominal reduction ratio and actual reduction ratio

Note that there is a difference between the nominal reduction ratio and actual reduction ratio of each gear head. Refer to the table below. When using the gear head, calculate the speed based on the actual reduction ratio.

* Gear heads dedicated to C&B motors have the same nominal reduction ratio and actual reduction ratio.

Example: nominal reduction ratio 1/3; actual reduction ratio 1/3

For practical use, calculate the speed based on the actual reduction ratio.

• Gear head

Nominal reduction ratio	Actual reduction ratio									
	M4GA□	MX6G□	MX7G□	MX8G□	MX9G□	MZ9G□ MY9G□	MR9G□ MP9G□	Right-angle type MX9G□R	Right-angle type MZ9G□R	for C&B motor
1/3	1/3	1/2.96	1/2.99	1/3.01	1/2.98	1/3.02	—	1/3.05	1/3.00	1/3
1/3.6	1/3.6	1/3.59	1/3.64	1/3.60	1/3.59	1/3.61	—	1/3.65	1/3.62	1/3.6
1/5	1/5	1/5.04	1/4.95	1/4.98	1/5.00	1/5.03	—	1/5.06	1/4.97	1/5
1/6	1/6	1/6.01	1/6.08	1/5.96	1/6.00	1/6.02	—	1/5.93	1/6.00	1/6
1/7.5	1/7.5	1/7.49	1/7.48	1/7.48	1/7.54	1/7.58	—	1/7.50	1/7.57	1/7.5
1/9	1/9	1/9.07	1/8.98	1/9.00	1/9.07	1/9.06	—	1/9.09	1/9.14	1/9
1/10	—	1/9.91	1/10.1	1/9.99	1/9.90	1/10.2	—	—	—	1/10
1/12.5	1/12.5	1/12.7	1/12.6	1/12.5	1/12.5	1/12.3	—	1/12.5	1/12.6	1/12.5
1/15	1/15	1/15.1	1/14.9	1/14.9	1/14.9	1/14.8	—	1/15.2	1/15.2	1/15
1/18	1/18	1/18.0	1/18.0	1/18.1	1/18.0	1/18.0	—	1/17.8	1/17.8	1/18
1/20	—	1/19.8	1/19.8	1/20.1	1/20.0	1/19.9	—	—	—	1/20
1/25	1/25	1/25.0	1/25.3	1/25.1	1/25.3	1/25.5	—	1/25.0	1/25.3	1/25
1/30	1/30	1/29.7	1/30.2	1/30.3	1/30.4	1/30.1	—	1/30.2	1/30.4	1/30
1/36	1/36	1/36.4	1/36.4	1/36.4	1/36.5	1/36.1	—	1/36.3	1/36.2	1/36
1/50	1/50	1/50.4	1/49.8	1/49.8	1/50.2	1/50.9	1/50.9	1/49.4	1/49.6	1/50
1/60	1/60	1/59.6	1/59.9	1/61.2	1/61.3	1/60.5	1/60.5	1/60.5	1/59.8	1/60
1/75	1/75	1/75.8	1/75.4	1/76.2	1/74.6	1/76.0	1/76.0	1/74.1	1/75.6	1/75
1/90	1/90	1/90.1	1/90.8	1/90.5	1/88.3	1/89.8	1/89.8	1/90.7	1/90.0	1/90
1/100	1/100	1/98.9	1/100.7	1/98.0	1/97.8	1/98.6	1/98.6	1/100.0	1/101.2	1/100
1/120	1/120	1/119.3	1/119.2	1/122.5	1/120.0	1/121.2	1/121.2	1/121.2	1/121.9	1/120
1/150	1/150	1/148.9	1/147.6	1/148.9	1/146.5	1/150.4	1/150.4	1/154.6	1/151.1	1/150
1/180	1/180	1/179.3	1/180.0	1/183.5	1/177.0	1/182.1	1/182.1	1/182.2	1/182.2	1/180
1/200	—	—	—	—	—	1/202.1	1/202.1	—	1/202.4	1/200

• Decimal gear head

Nominal reduction ratio	Actual reduction ratio				
	MX6G10XB	MX7G10XB	MX8G10XB	MX9G10XB	MZ9G10XB
1/10	1/10.04	1/9.93	1/9.94	1/10.0	1/9.97

Outline of gear head

Gear head efficiency

Model No.	Reduction ratio																			Decimal gear head				
	3	3.6	5	6	7.5	9	10	12.5	15	18	20	25	30	36	50	60	75	90	100		120	150	180	200
M4GA□F			72 %				—		61 %		—		52 %					41 %						—
MX6G□B																								—
MX7G□B																								—
MX8G□B																								—
MX9G□B																								—
MZ9G□B																								—
MY9G□B																								—
MR9G□B																								—
MP9G□B																								—
MX6G□M																								—
MX7G□M																								—
MX8G□M																								—
MX9G□M																								—
MX9G□R																								—
MZ9G□R																								—
MX6G□H																								—
MX7G□H																								—
MX8G□H																								—
MX9G□H																								—
MY9G□H																								—

* When the decimal gear head is used, the total efficiency is the product of gear head efficiency and decimal gear head efficiency.

Gear head efficiency and ambient temperature

Calculate the actual gear head efficiency by multiplying the above-shown gear head efficiency at room temperature by the torque reduction ratio shown below.

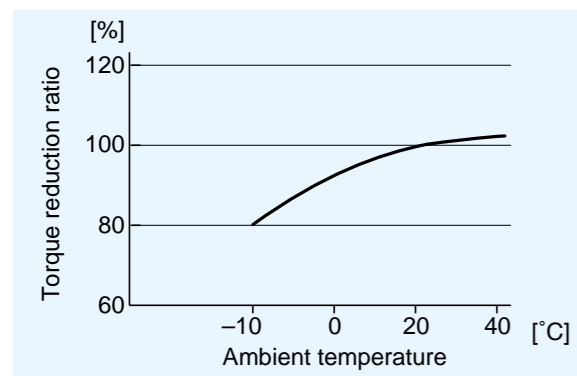

Overhung load and thrust load

The overhung load is defined as a load applied to the output shaft in the right-angle direction. This load is generated when the gear head is coupled to the machine using a chain, belt, etc., but not when the gear head is directly connected to the coupling. As shown in the figure below, the permissible value is determined based on the load applied to the L/2 position of the output shaft.

The thrust load is defined as a load applied to the output shaft in the axial direction.

Because the overhung load and thrust load significantly affect the life of the bearing, take care not to allow the load during operation to exceed the permissible overhung load and thrust load shown in the table below.

• Overhung load and thrust load

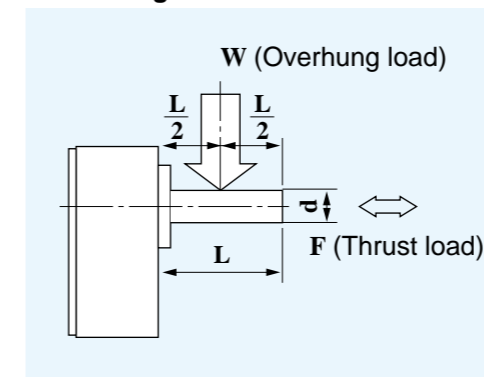

• Permissible load list

Size	Model	Permissible overhung load			Permissible thrust load		
		N	kgf	lb	N	kgf	lb
42 mm sq. (1.65 inch sq.)	M4GA□F	20	2	4.4	15	1.5	3.3
60 mm sq. (2.36 inch sq.)	MX6G□B(A)	98	10	22	29	3	6.6
	MX6G□M(A)	49	5	11			
70 mm sq. (2.76 inch sq.)	MX7G□B(A)	196	20	44	39	4	8.8
	MX7G□M(A)	98	10	22			
80 mm sq. (3.15 inch sq.)	MX8G□B	294	30	66	49	5	11
	MX8G□M	196	20	44			
90 mm sq. (3.54 inch sq.)	MX9G□B	392	40	88	98	10	22
	MX9G□M	294	30	66			
	MY9G□B	588	60	132			
90 mm sq. (3.54 inch sq.) High torque type	MR9G□B	784	80	176	147	15	33
	MP9G□B						
90 mm sq. (3.54 inch sq.) Right-angle type	MX9G□R	392	40	88	98	10	22
	MZ9G□R	588	60	132			

Service factor

Life expectancy of motor varies depending on load fluctuation. To determine the life expectancy, a factor called service factor, as shown in the table below is used. First choose the appropriate service factor according to the type of load and multiply the result by the required power to determine the design power.

• Service factor

Type of load	Typical load	Service factor		
		5 hours/day	8 hours/day	24 hours/day
Constant	Belt conveyor, One-directional rotation	0.8	1.0	1.5
Light-impact	Start/Stop, Cam-drive	1.2	1.5	2.0
Medium-impact	Instant FWD/REV, Instant stop	1.5	2.0	2.5
Heavy-impact	Frequent medium-impact	2.5	3.0	3.5

The required allowable shaft torque T_A of the gear head can be determined based on the service factor and actual load torque T_1 :

$$T_A = T_1 \times S_r$$

T_A : Allowable torque of gear head (N·m)
 T_1 : Actual load torque (N·m)
 S_r : Service factor

Use the motor so that the allowable torque T_A calculated from the formula above falls within the allowable torque range.

* Though it seems that the motor can be operated even in overload when the service factor is 0.8, note that the service factor is defined for the allowable torque of the gear head. If the motor is operated in overload, the life of insulator may be shortened or the motor may be burned out due to an abnormal temperature rise.

Outline of gear head

Standard life expectancy

Standard life expectancy: Standard life expectancy when operated for 8 hours/day at the standard load (Service factor=1.0)

* The oil seal is excluded because it is a consumable.

• Calculation of life expectancy

Calculate the life expectancy while referring to the service factor table shown last page.

When the service factor is 2.0, for example, the life expectancy is calculated as follows:

Life expectancy = 10000 (h) / 2.0 = 5000 (h)

• Standard life expectancy

	Life (hours)
Ball bearing Decimal gear head	10000 hours *
Metal bearing Right-angle 42 mm sq.	2000 hours
for C&B motor	5000 hours

* 5000 hours when used on reversible motor

Preparation

- (1) Prepare a gear head that matches a motor described in this manual.
Use of incompatible gear head will cause malfunction.
- (2) Check O-ring being correctly placed in a right place. If it is not, this may result in grease in the gear head coming out.
- (3) Wipe off any grease on the gear head flange surface.

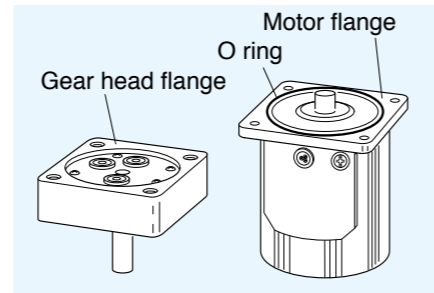

Assembling

- (1) Place the unit so that the motor shaft faces up.
Direction of the motor lead and output shaft of gear head must match an application.
- (2) Do not contact a tooth tip of pinion shaft to a tooth tip of gear head.
Set each toothes of motor and gear head correctly and gently press and turn the gear head in counter and counter-clockwise.
- (3) To attach the gear head to an application, use the "attaching screws" supplied with the gear head and tighten the screws with appropriate torque and with care not to pinch the O ring, so that the there is no gap between motor flange and gear flange.
- (4) The recommended torque is shown below.

Size	Screw size	Tightening torque	
		N-m	lb-in
42 mm sq. (1.65 inch sq.)	M3	0.6 to 1	5.31 to 8.85
60 mm sq. (2.36 inch sq.)	M4	2 to 2.5	17.7 to 22.1
70 mm sq. (2.76 inch sq.)	M5	2.5 to 3	22.1 to 26.6
80 mm sq. (3.15 inch sq.)	M5	2.5 to 3	22.1 to 26.6
90 mm sq. (3.54 inch sq.)	M6	3.5 to 4.5	31.0 to 39.8

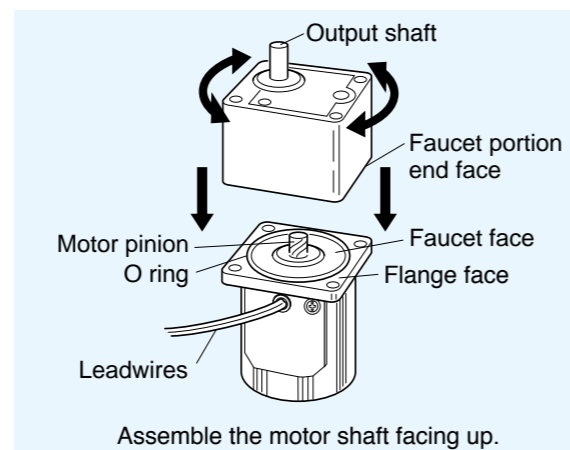

• O-ring

Repair parts
10 pcs packed in one bag.

Size (mm)	Part number
60 mm (2.36 inch) sq.	DV0PN10006
70 mm (2.76 inch) sq.	DV0PN10007
80 mm (3.15 inch) sq.	DV0PN10008
90 mm (3.54 inch) sq.	DV0PN10009

(5) Tighten the screws correctly.

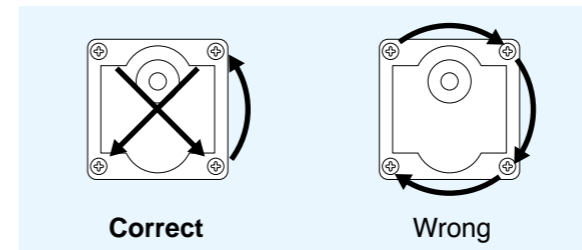

<Note>

Do not forcedly assemble the motor and gear head. Do not damage the tooth of the motor pinion and gear head.

Incorrect assembly results in abnormal noise generation or shortened unit life.

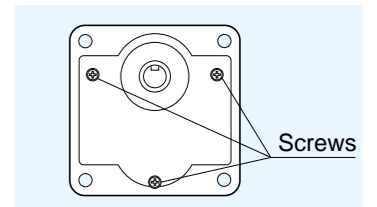

Considerations for installation of gear head

You may experience a slipping gear contact due to broken pinion tooth, locked gear or leaked grease as the gear head life comes closer.

Place a safety device to keep safe operation at any time even if such problems take place.

- Place a drop-proof device in an vertically motioned application like a lifter.
- Place a device to open the door in a door application just in case the gear head is locked.
- Place an oil pan to prevent oil from coming out in an application like food/textile etc.
- Do not place an encoder, sensor, contact, etc near a gear head where the grease may leaking out. If not, please have a protection from grease.
- Have a routain check of the gear head to avoid unexpected accident.

<Precautions>

Keep the gear head attached to the motor. Otherwise, the O ring may become distorted or damaged, causing grease leakage.

- When reassembling, first replace the O ring with a new one.
- When installing a motor associated with the gear head to the application device, temporarily secure the motor and gear head with a tape until assembly completes.

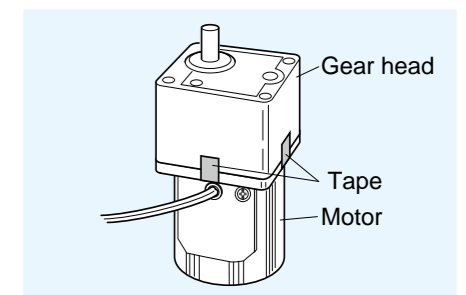

Considerations for storage of gear head

When storing the gear head as a single unit, place it with the output shaft facing down.
(To prevent grease leakage)

Model list of gear head

Gear head

• Ball bearing

Size	Reduction ratio	Model No.	Hinge	
60 mm sq. (2.36 inch sq.)	1/3, 1/3.6, 1/5, 1/6, 1/7.5, 1/9, 1/10, 1/12.5, 1/15, 1/18	MX6G3BA – MX6G18BA		
	1/20, 1/25, 1/30, 1/36	MX6G20BA – MX6G36B		
	1/50, 1/60, 1/75, 1/90, 1/100, 1/120, 1/150, 1/180	MX6G50B – MX6G180B		
70 mm sq. (2.76 inch sq.)	1/3, 1/3.6, 1/5, 1/6, 1/7.5, 1/9, 1/10, 1/12.5, 1/15, 1/18	MX7G3BA – MX7G18BA		
	1/20, 1/25, 1/30, 1/36	MX7G20BA – MX7G36B		
	1/50, 1/60, 1/75, 1/90, 1/100, 1/120, 1/150, 1/180	MX7G50B – MX7G180B		
80 mm sq. (3.15 inch sq.)	1/3, 1/3.6, 1/5, 1/6, 1/7.5, 1/9, 1/10, 1/12.5, 1/15, 1/18	MX8G3B – MX8G18B		
	1/20, 1/25, 1/30, 1/36	MX8G20B – MX8G36B		
	1/50, 1/60, 1/75, 1/90, 1/100, 1/120, 1/150, 1/180	MX8G50B – MX8G180B		
90 mm sq. (3.54 inch sq.)	40 W	1/3, 1/3.6, 1/5, 1/6, 1/7.5, 1/9, 1/10, 1/12.5, 1/15, 1/18	MX9G3B – MX9G18B	
		1/20, 1/25, 1/30, 1/36	MX9G20B – MX9G36B	
		1/50, 1/60, 1/75, 1/90, 1/100, 1/120, 1/150, 1/180	MX9G50B – MX9G180B	
	Common to 60 W, 90 W	1/3, 1/3.6, 1/5, 1/6, 1/7.5, 1/9	MZ9G3B – MZ9G9B	
		1/10, 1/12.5, 1/15, 1/18	MZ9G10B – MZ9G18B	
		1/20, 1/25, 1/30, 1/36, 1/50, 1/60	MZ9G20B – MZ9G60B	
		1/75, 1/90, 1/100, 1/120, 1/150, 1/180, 1/200	MZ9G75B – MZ9G200B	
		1/3, 1/3.6, 1/5, 1/6, 1/7.5, 1/9	MY9G3B – MY9G9B	○
		1/10, 1/12.5, 1/15, 1/18	MY9G10B – MY9G18B	○
		1/20, 1/25, 1/30, 1/36, 1/50, 1/60	MY9G20B – MY9G60B	○
		1/75, 1/90, 1/100, 1/120, 1/150, 1/180, 1/200	MY9G75B – MY9G200B	○

* For the specifications for each item, refer to the page of the motor to which it can be applied.

• Metal bearing

Size	Reduction ratio	Model No.	Hinge	
60 mm sq. (2.36 inch sq.)	1/3, 1/3.6, 1/5, 1/6, 1/7.5, 1/9, 1/10, 1/12.5, 1/15, 1/18	MX6G3MA – MX6G18MA		
	1/20, 1/25, 1/30, 1/36	MX6G20MA – MX6G36M		
	1/50, 1/60, 1/75, 1/90, 1/100, 1/120, 1/150, 1/180	MX6G50M – MX6G180M		
70 mm sq. (2.76 inch sq.)	1/3, 1/3.6, 1/5, 1/6, 1/7.5, 1/9, 1/10, 1/12.5, 1/15, 1/18	MX7G3MA – MX7G18MA		
	1/20, 1/25, 1/30, 1/36	MX7G20MA – MX7G36M		
	1/50, 1/60, 1/75, 1/90, 1/100, 1/120, 1/150, 1/180	MX7G50M – MX7G180M		
80 mm sq. (3.15 inch sq.)	1/3, 1/3.6, 1/5, 1/6, 1/7.5, 1/9, 1/10, 1/12.5, 1/15, 1/18	MX8G3M – MX8G18M		
	1/20, 1/25, 1/30, 1/36	MX8G20M – MX8G36M		
	1/50, 1/60, 1/75, 1/90, 1/100, 1/120, 1/150, 1/180	MX8G50M – MX8G180M		
90 mm sq. (3.54 inch sq.)	40 W	1/3, 1/3.6, 1/5, 1/6, 1/7.5, 1/9, 1/10, 1/12.5, 1/15, 1/18	MX9G3M – MX9G18M	
		1/20, 1/25, 1/30, 1/36	MX9G20M – MX9G36M	
		1/50, 1/60, 1/75, 1/90, 1/100, 1/120, 1/150, 1/180	MX9G50M – MX9G180M	

* For the specifications for each item, refer to the page of the motor to which it can be applied.

• Ball bearing and metal bearing

Size	Reduction ratio	Model No.	Hinge
42 mm sq. (1.65 inch sq.)	1/3, 1/3.6, 1/5, 1/6, 1/7.5, 1/9, 1/12.5, 1/15, 1/18	M4GA3F – M4GA18F	
	1/25, 1/30, 1/36, 1/50, 1/60	M4GA25F – M4GA60F	
	1/75, 1/90, 1/100, 1/120, 1/150, 1/180	M4GA75F – M4GA180F	

* For the specifications for each item, refer to the page of the motor to which it can be applied.

• High torque gear head

Size	Reduction ratio	Model No.	Hinge
90 mm sq. (3.54 inch sq.)	1/50, 1/60	MR9G50B – MR9G60B	
	1/75, 1/90, 1/100, 1/120, 1/150, 1/180, 1/200	MR9G75B – MR9G200B	
	1/50, 1/60	MP9G50B – MP9G60B	○
	1/75, 1/90, 1/100, 1/120, 1/150, 1/180, 1/200	MP9G75B – MP9G200B	○

• Right-angle gear head

Size	Reduction ratio	Model No.	Hinge	
90 mm sq. (3.54 inch sq.)	40 W	1/3, 1/3.6, 1/5, 1/6, 1/7.5, 1/9, 1/12.5, 1/15, 1/18	MX9G3R – MX9G18R	
		1/25, 1/30, 1/36,	MX9G25R – MX9G36R	
		1/50, 1/60, 1/75, 1/90, 1/100, 1/120, 1/150, 1/180	MX9G50R – MX9G180R	
	Common to 60 W, 90 W	1/3, 1/3.6, 1/5, 1/6, 1/7.5, 1/9, 1/12.5, 1/15, 1/18, 1/25	MZ9G3R – MZ9G25R	
		1/30, 1/36, 1/50, 1/60,	MZ9G30R – MZ9G60R	
		1/75, 1/90, 1/100, 1/120, 1/150, 1/180, 1/200	MZ9G75R – MZ9G200R	

• Gear head for C&B motor (Ball bearing)

* The details refer to B-342.

Size	Reduction ratio	Model No.	Hinge	
60 mm sq. (2.36 inch sq.)	1/3, 1/3.6, 1/5, 1/6, 1/7.5, 1/9, 1/10, 1/12.5, 1/15, 1/18	MX6G3H – MX6G18H		
	1/20, 1/25, 1/30, 1/36	MX6G20H – MX6G36H		
	1/50, 1/60, 1/75, 1/90, 1/100, 1/120, 1/150, 1/180	MX6G50H – MX6G180H		
70 mm sq. (2.76 inch sq.)	1/3, 1/3.6, 1/5, 1/6, 1/7.5, 1/9, 1/10, 1/12.5, 1/15, 1/18	MX7G3H – MX7G18H		
	1/20, 1/25, 1/30, 1/36	MX7G20H – MX7G36H		
	1/50, 1/60, 1/75, 1/90, 1/100, 1/120, 1/150, 1/180	MX7G50H – MX7G180H		
80 mm sq. (3.15 inch sq.)	1/3, 1/3.6, 1/5, 1/6, 1/7.5, 1/9, 1/10, 1/12.5, 1/15, 1/18	MX8G3H – MX8G18H		
	1/20, 1/25, 1/30, 1/36	MX8G20H – MX8G36H		
	1/50, 1/60, 1/75, 1/90, 1/100, 1/120, 1/150, 1/180,	MX8G50H – MX8G180H		
90 mm sq. (3.54 inch sq.)	40 W	1/3, 1/3.6, 1/5, 1/6, 1/7.5, 1/9, 1/10, 1/12.5, 1/15, 1/18	MX9G3H – MX9G18H	
		1/20, 1/25, 1/30, 1/36	MX9G20H – MX9G36H	
		1/50, 1/60, 1/75, 1/90, 1/100, 1/120, 1/150, 1/180	MX9G50H – MX9G180H	
	Common to 60 W, 90 W	1/3, 1/3.6, 1/5, 1/6, 1/7.5, 1/9	MY9G3H – MY9G9H	○
		1/10, 1/12.5, 1/15, 1/18, 1/20, 1/25, 1/30, 1/36, 1/50, 1/60	MY9G10H – MY9G60H	○
		1/75, 1/90, 1/100, 1/120, 1/150, 1/180, 1/200	MY9G70H – MY9G200H	○

* For the specifications for each item, refer to the page of the motor to which it can be applied.

Model list of gear head

Gear head accessory

• Ball bearing / Metal bearing / Ball bearing and metal bearing

Size	Reduction ratio	Model No.	Accessory				Unit: mm (inch)
			Screw	Flat washer	Hexagon nut	Key	
42 mm sq. (1.65 inch sq.)	1/3 to 1/180	M4GA3F – M4GA180F	M3P0.5 x 38 (1.50) pan head screw: 2	For M3P0.5: 2	M3P0.5: 2	—	
60 mm sq. (2.36 inch sq.)	1/3 to 1/25	MX6G3BA – MX6G25BA	M4P0.7 x 40 (1.57) pan head screw: 4	For M4P0.7: 4	M4P0.7: 4	—	
	1/30 to 1/180	MX6G30B – MX6G180B	M4P0.7 x 50 (1.97) pan head screw: 4	For M4P0.7: 4	M4P0.7: 4	—	
70 mm sq. (2.76 inch sq.)	1/3 to 1/25	MX7G3BA – MX7G25BA	M5P0.8 x 50 (1.97) pan head screw: 4	For M5P0.8: 4	M5P0.8: 4	4 x 4 x 25 (0.16 x 0.16 x 0.98) one-end round: 1	
	1/30 to 1/180	MX7G30B – MX7G180B	M5P0.8 x 55 (2.17) pan head screw: 4	For M5P0.8: 4	M5P0.8: 4	4 x 4 x 25 (0.16 x 0.16 x 0.98) one-end round: 1	
80 mm sq. (3.15 inch sq.)	1/3 to 1/180	MX8G3B – MX8G180B	M5P0.8 x 55 (2.17) pan head screw: 4	For M5P0.8: 4	M5P0.8: 4	4 x 4 x 25 (0.16 x 0.16 x 0.98) one-end round: 1	
90 mm sq. (3.54 inch sq.)	Common to 40 W, 60 W, 90 W	1/3 to 1/180	M6P1.0 x 65 (2.56) pan head screw: 4	For M6P1.0: 4	M6P1.0: 4	4 x 4 x 25 (0.16 x 0.16 x 0.98) one-end round: 1	
		1/3 to 1/200	MZ9G3B – MZ9G200B	For M6P1.0: 4	M6P1.0: 4	5 x 5 x 25 (0.20 x 0.20 x 0.98) one-end round: 1	
		1/3 to 1/200	MY9G3B – MY9G200B	M6P1.0 x 25 (0.98) hexagon socket head bolt: 4	For M6P1.0: 4	M6P1.0: 4	5 x 5 x 25 (0.20 x 0.20 x 0.98) one-end round: 1

• High torque gear head

Size	Reduction ratio	Model No.	Accessory				Unit: mm (inch)
			Screw	Flat washer	Hexagon nut	Key	
90 mm sq. (3.54 inch sq.)	1/50 to 1/200	MR9G50B – MR9G200B	M6P1.0 x 20 (0.79) hexagon socket head bolt: 4	For M6P1.0: 4	—	6 x 6 x 30 (0.24 x 0.24 x 1.18) one-end round: 1	
	1/50 to 1/200	MP9G50B – MP9G200B	M6P1.0 x 25 (0.98) hexagon socket head bolt: 4	For M6P1.0: 4	M6P1.0: 4	6 x 6 x 30 (0.24 x 0.24 x 1.18) one-end round: 1	

• Right-angle gear head

Size	Reduction ratio	Model No.	Accessory				Unit: mm (inch)
			Screw	Flat washer	Hexagon nut	Key	
90 mm sq. (3.54 inch sq.)	Common to 40 W, 60 W, 90 W	1/3 to 1/180	MX9G3R – MX9G180R	For M6P1.0: 4	—	4 x 4 x 25 (0.16 x 0.16 x 0.98) one-end round: 1	
		1/3 to 1/200	MZ9G3R – MZ9G200R	For M6P1.0: 4	—	5 x 5 x 25 (0.20 x 0.20 x 0.98) one-end round: 1	

• Gear head for C&B motor

Size	Reduction ratio	Model No.	Accessory			Unit: mm (inch)
			Screw	Flat washer	Key	
60 mm sq. (2.36 inch sq.)	1/3 to 1/18	MX6G3H – MX6G18H	M4P0.7 x 40 (1.57) pan head screw: 4	For M4P0.7: 4	—	
	1/25 to 1/180	MX6G20H – MX6G180H	M4P0.7 x 50 (1.97) pan head screw: 4	For M4P0.7: 4	—	
70 mm sq. (2.76 inch sq.)	1/3 to 1/18	MX7G3H – MX7G18H	M5P0.8 x 55 (2.17) pan head screw: 4	For M5P0.8: 4	4 x 4 x 25 (0.16 x 0.16 x 0.98) one-end round: 1	
	1/25 to 1/180	MX7G20H – MX7G180H	M5P0.8 x 65 (2.56) pan head screw: 4	For M5P0.8: 4	4 x 4 x 25 (0.16 x 0.16 x 0.98) one-end round: 1	
80 mm sq. (3.15 inch sq.)	1/3 to 1/18	MX8G3H – MX8G18H	M5P0.8 x 55 (2.17) pan head screw: 4	For M5P0.8: 4	4 x 4 x 25 (0.16 x 0.16 x 0.98) one-end round: 1	
	1/25 to 1/180	MX8G20H – MX8G180H	M5P0.8 x 65 (2.56) pan head screw: 4	For M5P0.8: 4	4 x 4 x 25 (0.16 x 0.16 x 0.98) one-end round: 1	
90 mm sq. (3.54 inch sq.)	1/3 to 1/18	MX9G3H – MX9G18H	M6P1.0 x 70 (2.76) pan head screw: 4	For M6P1.0: 4	4 x 4 x 25 (0.16 x 0.16 x 0.98) one-end round: 1	
	1/25 to 1/180	MX9G20H – MX9G180H	M6P1.0 x 85 (3.35) pan head screw: 4	For M6P1.0: 4	4 x 4 x 25 (0.16 x 0.16 x 0.98) one-end round: 1	
	1/3 to 1/200	MY9G3H – MY9G200H	M6P1.0 x 25 (0.98) hexagon socket head bolt: 4	For M6P1.0: 4	5 x 5 x 25 (0.20 x 0.20 x 0.98) one-end round: 1	

* Though a hexagon nut is supplied with the accessories, it is not necessary in mounting the gear head.

Decimal gear head (Cannot be used for C&B motor)

Size	Reduction ratio	Model No.	Applicable gear head	Page
60 mm sq. (2.36 inch sq.)	1/10	MX6G10XB	MX6G□BA MX6G□B	B-448
70 mm sq. (2.76 inch sq.)	1/10	MX7G10XB	MX7G□BA MX7G□B	B-448
80 mm sq. (3.15 inch sq.)	1/10	MX8G10XB	MX8G□B	B-448
90 mm sq. (3.54 inch sq.)	Common to 40 W, 60 W, 90 W	1/10	MX9G10XB	MX9G□B
		1/10	MZ9G10XB	MZ9G□B MY9G□B MR9G□B MP9G□B

• Decimal gear head mouting screw (specification)

Size	Reduction ratio	Applicable gear head	Specification [Unit: mm(inch)]	
60 mm sq. (2.36 inch sq.)	MX6G10XB	MX6G□BA	Cross recessed pan head screw M4 pitch 0.7, length 85(3.35): 4	
		MX6G□B		
		MX6G□MA MX6G□M		
70 mm sq. (2.76 inch sq.)	MX7G10XB	MX7G□BA	Cross recessed pan head screw M5 pitch 0.8, length 95(3.74): 4	
		MX7G□B		
		MX7G□MA MX7G□M		
80 mm sq. (3.15 inch sq.)	MX8G10XB	MX8G□B MX8G□M	Cross recessed pan head screw M5 pitch 0.8, length 85(3.35): 4	
90 mm sq. (3.54 inch sq.)	Common to 40 W, 60 W, 90 W	MX9G10XB	MX9G□B MX9G□M	Cross recessed pan head screw M6 pitch 1.0, length 100(3.94): 4
		MZ9G10XB	MZ9G□B	Cross-recessed hex head bolt M6 pitch 1.0, length 125(4.92): 4
			MY9G□B MR9G□B MP9G□B	Cross recessed pan head screw M6 pitch 1.0, length 65(2.56): 4

• Type of high torque gear head

Model No.	Dimensions	Gear head scale: 1/4, Key scale: 1/2, Unit: mm (inch)	Gear mounting screw
MR9G□B (Ball bearing) Hinge not attached		Mass 1.7 kg 3.7 lb	M6P1.0 x 20(0.79) [4 pieces attachment]
MP9G□B (Ball bearing) Hinge attached		Mass 1.7 kg 3.7 lb	M6P1.0 x 25(0.98) [4 pieces attachment]

* Cannot be attached to the C&B motor.

Allowable shaft torque with high torque gear head directly connected

* The number of revolutions is calculated based on the synchronous rotating speed (1500 r/min, 1800 r/min). Usually, actual speed is slow by 2 % to 20 % the value shown in the table, depending on load condition.

• Hinge not attached 90 mm sq. (3.54 inch sq.) / 60 W Unit of permissible torque: upper (N·m) / lower (lb-in)

Reduction ratio	Speed (r/min)								
	50 Hz	60	75	90	100	120	150	180	200
50 Hz	30	25	20	16.7	15	12.5	10	8.3	7.5
60 Hz	36	30	24	20	18	15	12	10	9
Applicable gear head MR9G50B– MR9G200B (ball bearing hinge not attached)	50 Hz	15.2 (135)	18.2 (161)	22.1 (196)	26.5 (235)	29.4 (260)			
	60 Hz	12.7 (112)	15.2 (135)	18.6 (165)	22.1 (196)	24.6 (218)	29.4 (260)		
Rotational direction Same as motor rotational direction									

• Hinge not attached 90 mm sq. (3.54 inch sq.) / 90 W Unit of permissible torque: upper (N·m) / lower (lb-in)

Reduction ratio	Speed (r/min)								
	50 Hz	60	75	90	100	120	150	180	200
50 Hz	30	25	20	16.7	15	12.5	10	8.3	7.5
60 Hz	36	30	24	20	18	15	12	10	9
Applicable gear head MR9G50B– MR9G200B (ball bearing hinge not attached)	50 Hz	21.2 (188)	25.5 (226)	29.4 (260)					
	60 Hz	18.3 (162)	21.2 (188)	26.7 (236)	29.4 (260)				
Rotational direction Same as motor rotational direction									

• Permissible torque at output shaft of gear head using decimal gear head

Applicable gear head	Reduction ratio	Speed (r/min)									
		500	600	750	900	1000	1200	1500	1800	2000	
Bearing	Decimal gear head	50 Hz	3	2.5	2	1.7	1.5	1.3	1	0.83	0.75
		60 Hz	3.6	3	2.4	2	1.8	1.5	1.2	1	0.9
MR9G□B (ball bearing hinge not attached)	MZ9G10XB	Permissible torque	N·m (lb-in)	29.4 (260)	29.4 (260)	29.4 (260)	29.4 (260)	29.4 (260)	29.4 (260)	29.4 (260)	29.4 (260)
		Rotational direction	Same as motor rotational direction								

* Please read your User's manual carefully so that you will understand the operation and safety precautions before attempting to operate the system.

Allowable shaft torque with high torque gear head directly connected

* The number of revolutions is calculated based on the synchronous rotating speed (1500 r/min, 1800 r/min). Usually, actual speed is slow by 2 % to 20 % the value shown in the table, depending on load condition.

• With hinge Sq.90 mm (3.54 inch sq.) / 60 W Unit of permissible torque: upper (N·m) / lower (lb-in)

Speed reduction ratio	Rotating speed (r/min)								
	50 Hz	60	75	90	100	120	150	180	200
50 Hz	30	25	20	16.7	15	12.5	10	8.3	7.5
60 Hz	36	30	24	20	18	15	12	10	9
Applicable gear head MP9G50B– MP9G200B (Ball bearing, with hinge)	50 Hz	15.2 (135)	18.2 (161)	22.1 (196)	26.5 (235)	29.4 (260)			
	60 Hz	12.7 (112)	15.2 (135)	18.6 (165)	22.1 (196)	24.6 (218)	29.4 (260)		
Rotation direction Same as on the motor									

• With hinge Sq.90 mm (3.54 inch sq.) / 90 W Unit of permissible torque: upper (N·m) / lower (lb-in)

Speed reduction ratio	Rotating speed (r/min)								
	50 Hz	60	75	90	100	120	150	180	200
50 Hz	30	25	20	16.7	15	12.5	10	8.3	7.5
60 Hz	36	30	24	20	18	15	12	10	9
Applicable gear head MP9G50B– MP9G200B (Ball bearing, with hinge)	50 Hz	21.2 (118)	25.5 (226)	29.4 (260)					
	60 Hz	18.3 (162)	21.2 (188)	26.7 (236)	29.4 (260)				
Rotation direction Same as on the motor									

• When intermediate gear head is used

Applicable gear head	Speed reduction ratio	Rotating speed (r/min)	500	600	750	900	1000	1200	1500	1800	2000
			3	2.5	2	1.7	1.5	1.3	1	0.83	0.75
Bearing	Intermediate gear head	50 Hz	3	2.5	2	1.7	1.5	1.3	1	0.83	0.75
		60 Hz	3.6	3	2.4	2	1.8	1.5	1.2	1	0.9
MP9G□B (Ball bearing, with hinge)	MZ9G10XB	Allowable shaft torque	N·m (lb-in)	29.4 (260)	29.4 (260)	29.4 (260)	29.4 (260)	29.4 (260)	29.4 (260)	29.4 (260)	29.4 (260)
		Rotation direction	Same as on the motor								

(Note) Because the dimensions may be subject to change, also check the determinate dimensions if the gear head is to be used for design.

• Type of right-angle gear head

Model No.	Dimensions	Gear head scale: 1/4, Key scale: 1/2, Unit: mm (inch)	Gear mounting screw
MX9G□R (Ball bearing)	<p>Mass 2.5 kg 5.5 lb</p> <p>Motor mounting surface</p> <p>Motor mounting surface</p> <p>Key (dimensions) [attachment]</p>		M6P1.0 x 20(0.79) 4 pieces attachment
MZ9G□R (Ball bearing)	<p>Mass 2.5 kg 5.5 lb</p> <p>Motor mounting surface</p> <p>Motor mounting surface</p> <p>Key (dimensions) [attachment]</p>		M6P1.0 x 20(0.79) 4 pieces attachment

* Cannot be attached to the C&B motor.

Allowable shaft torque with right-angle type gear head directly connected

* The number of revolutions is calculated based on the synchronous rotating speed (1500 r/min, 1800 r/min). Usually, actual speed is slow by 2 % to 20 % the value shown in the table, depending on load condition.

• 90 mm sq. (3.54 inch sq.) / 40 W

Unit of permissible torque: upper (N·m) / lower (lb-in)

Reduction ratio	3 3.6 5 6 7.5 9 12.5 15 18 25 30 36 50 60 75 90 100 120 150 180																					
	50 Hz	500	416.7	300	250	200	166.7	120	100	83.3	60	50	41.7	30	25	20	16.7	15	12.5	10	8.3	
Speed (r/min)	60 Hz	600	500	360	300	240	200	144	120	100	72	60	50	36	30	24	20	18	15	12	10	
Applicable gear head	MX9G3R – MX9G180R (ball bearing)	50 Hz	0.60 (5.31)	0.72 (6.37)	0.98 (8.67)	1.18 (10.4)	1.47 (13.0)	1.76 (15.6)	2.45 (21.7)	2.94 (26.0)	3.53 (31.2)	5.00 (44.3)	6.00 (53.1)	7.18 (63.6)								9.80 (86.7)
		60 Hz	0.50 (4.43)	0.60 (5.31)	0.82 (7.26)	0.98 (8.67)	1.23 (10.9)	1.47 (13.0)	2.04 (18.1)	2.45 (21.7)	2.94 (26.0)	4.17 (36.9)	5.00 (44.3)	5.98 (52.9)	8.17 (72.3)							
Rotational direction		Same as motor rotational direction																				

• Permissible torque at output shaft of gear head using decimal gear head

Applicable gear head		Reduction ratio		250	300	360	500	600	750	900	1000	1200	1500	1800	
Bearing	Decimal gear head	Speed (r/min)	50 Hz	60 Hz	6	5	4.2	3	2.5	2	1.7	1.5	1.3	1	0.83
			60 Hz	7.2	6	5	3.6	3	2.4	2	1.8	1.5	1.2	1	
MX9G25R – MX9G180R	MX9G10XB	Permissible torque	N·m (lb-in)	9.80 (86.7)	9.80 (86.7)	9.80 (86.7)	9.80 (86.7)	9.80 (86.7)	9.80 (86.7)	9.80 (86.7)	9.80 (86.7)	9.80 (86.7)	9.80 (86.7)	9.80 (86.7)	9.80 (86.7)
		Rotational direction		Same as motor rotational direction											

* Please read your User's manual carefully so that you will understand the operation and safety precautions before attempting to operate the system.

Allowable shaft torque with right-angle type gear head directly connected

* The number of revolutions is calculated based on the synchronous rotating speed (1500 r/min, 1800 r/min). Usually, actual speed is slow by 2 % to 20 % the value shown in the table, depending on load condition.

• 90 mm sq. (3.54 inch sq.) / 60 W

Unit of permissible torque: upper (N·m) / lower (lb-in)

Reduction ratio	3 3.6 5 6 7.5 9 12.5 15 18 25 30 36 50 60 75 90 100 120 150 180 200																							
	50 Hz	500	416.7	300	250	200	166.7	120	100	83.3	60	50	41.7	30	25	20	16.7	15	12.5	10	8.3	7.5		
Speed (r/min)	60 Hz	600	500	360	300	240	200	144	120	100	72	60	50	36	30	24	20	18	15	12	10	9		
Applicable gear head	MZ9G3R – MZ9G200R (ball bearing)	50 Hz	0.90 (7.97)	1.15 (10.2)	1.50 (13.3)	1.92 (17.0)	2.20 (19.5)	2.81 (24.9)	3.70 (32.7)	4.40 (38.9)	5.62 (49.7)	7.40 (65.5)	8.80 (77.9)	11.2 (99.1)	14.8 (131)	18.9 (167)								19.6 (173)
		60 Hz	0.70 (6.20)	0.90 (7.97)	1.17 (10.4)	1.50 (13.3)	1.72 (15.2)	2.20 (19.5)	2.90 (25.7)	3.44 (30.4)	4.40 (38.9)	5.79 (51.2)	7.40 (65.5)	8.80 (77.9)	11.6 (103)	14.8 (131)	15.3 (135)							
Rotational direction		Same as motor rotational direction																						

• Permissible torque at output shaft of gear head using decimal gear head

Applicable gear head		Reduction ratio		250	300	360	500	600	750	900	1000	1200	1500	1800	2000	
Bearing	MX9G10XB	Speed (r/min)	50 Hz	60 Hz	6	5	4.2	3	2.5	2	1.7	1.5	1.3	1	0.83	0.75
			60 Hz	7.2	6	5	3.6	3	2.4	2	1.8	1.5	1.2	1	0.9	
MZ9G25R – MZ9G200R	MZ9G10XB	Permissible torque	N·m (lb-in)	19.6 (173)	19.6 (173)	19.6 (173)	19.6 (173)	19.6 (173)	19.6 (173)	19.6 (173)	19.6 (173)	19.6 (173)	19.6 (173)	19.6 (173)	19.6 (173)	19.6 (173)
		Rotational direction		Same as motor rotational direction												

• 90 mm sq. (3.54 inch sq.) / 90 W

Unit of permissible torque: upper (N·m) / lower (lb-in)

Reduction ratio	3 3.6 5 6 7.5 9 12.5 15 18 25 30 36 50 60 75 90 100 120 150 180 200																					
	50 Hz	500	416.7	300	250	200	166.7	120	100	83.3	60	50	41.7	30	25	20	16.7	15	12.5	10	8.3	7.5
Speed (r/min)	60 Hz	600	500	360	300	240	200	144	120	100	72	60	50	36	30	24	20	18	15	12	10	9
Applicable gear head	MZ9G3R – MZ9G200R (ball bearing)	50 Hz	1.30 (11.5)	1.59 (14.1)	2.30 (20.4)	2.82 (25.0)	3.30 (29.2)	4.05 (35.8)	5.60 (49.6)	6.80 (60.2)	8.34 (73.8)	10.6 (93.8)	12.7 (112)	15.6 (138)								19.6 (173)
		60 Hz	1.06 (9.38)	1.30 (11.5)	1.88 (16.6)	2.30 (20.4)	2.69 (23.8)	3.30 (29.2)	4.56 (40.4)	5.54 (49.0)	6.80 (60.2)	8.15 (72.1)	10.6 (93.8)	12.7 (112)	16.0 (142)							
Rotational direction		Same as motor rotational direction																				

• Permissible torque at output shaft of gear head using decimal gear head

Applicable gear head		Reduction ratio		250	300	360	500	600	750	900	1000	1200	1500	1800	2000	
Bearing	MX9G10XB	Speed (r/min)	50 Hz	60 Hz	6	5	4.2	3	2.5	2	1.7	1.5	1.3	1	0.83	0.75
			60 Hz	7.2	6	5	3.6	3	2.4	2	1.8	1.5	1.2	1	0.9	
MZ9G25R – MZ9G200R	MZ9G10XB	Permissible torque	N·m (lb-in)	19.6 (173)	19.6 (173)	19.6 (173)	19.6 (173)	19.6 (173)	19.6 (173)	19.6 (173)	19.6 (173)	19.6 (173)	19.6 (173)	19.6 (173)	19.6 (173)	19.6 (173)
		Rotational direction		Same as motor rotational direction												

(Note) Because the dimensions may be subject to change, also check the determinate dimensions if the gear head is to be used for design.

Decimal gear head Type of decimal gear head

• **Type of decimal gear head** * Mounting screws for decimal gear head: Please prepare by customer. * Shown in □ is a gear ratio.

Model No.	Dimensions Scale: 1/4, Unit: mm (inch)	Applicable gear head	Gear mounting screw (specification)
MX6G10XB	<p>Mass 0.23 kg 0.51 lb</p>	MX6G□BA MX6G□B MX6G□MA MX6G□M	<ul style="list-style-type: none"> • M4P0.7 x 85(3.35) • Cross recessed pan head screw (4 pieces) Required screw length: 30 mm (1.18 inch) or more
MX7G10XB	<p>Mass 0.35 kg 0.77 lb</p>	MX7G□BA MX7G□B MX7G□MA MX7G□M	<ul style="list-style-type: none"> • M5P0.8 x 95(3.74) • Cross recessed pan head screw (4 pieces) Required screw length: 35 mm (1.38 inch) or more
MX8G10XB	<p>Mass 0.39 kg 0.86 lb</p>	MX8G□B MX8G□M	<ul style="list-style-type: none"> • M5P0.8 x 85(3.35) • Cross recessed pan head screw (4 pieces) Required screw length: 20 mm (0.79 inch) or more
MX9G10XB	<p>Mass 0.53 kg 1.17 lb</p>	MX9G□B MX9G□M	<ul style="list-style-type: none"> • M6P1.0 x 100(3.94) • Cross recessed pan head screw (4 pieces) Required screw length: 25 mm (0.98 inch) or more
MZ9G10XB	<p>Mass 0.65 kg 1.43 lb</p>	MZ9G□B	<ul style="list-style-type: none"> • M6P1.0 x 125(4.92) • Hexagon socket head bolt (4 pieces) Required screw length: 15 mm (0.59 inch) or more
		MY9G□B MP9G□B MR9G□B	<ul style="list-style-type: none"> • M6P1.0 x 65(2.56) • Hexagon socket head bolt (4 pieces) Required screw length: 10 mm (0.39 inch) or more

* Fit tolerance symbol is used in the outside dimension diagram of motor and gear head.
For further information, see "Fit tolerance" on page A-33.

* Please read your User's manual carefully so that you will understand the operation and safety precautions before attempting to operate the system.

Gear Head -Inch (U.S.A.)

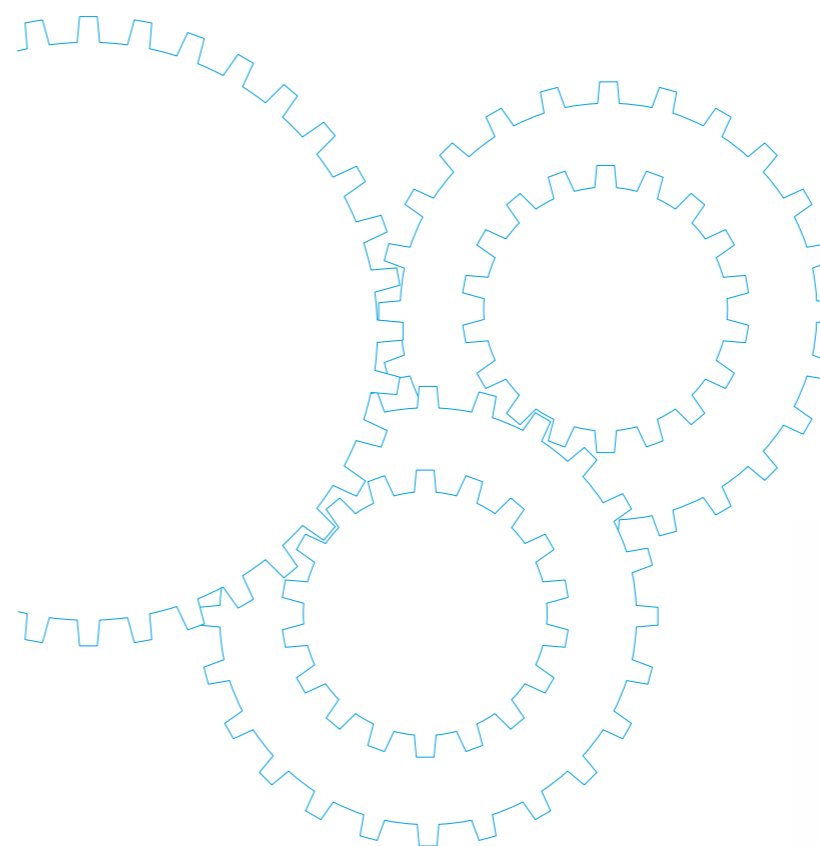

Contents

• Gear head Overview	B-450
• Gear head dimensions	B-451
• Gear head combination dimensions	B-452

Outline of Gear head -inch (U.S.A.)

Gear head -inch (U.S.A.)

Features

- These gear heads are designed according to “inch” system.
- All bearings are ball bearing.
- 22 reduction ratios from 1/3 to 1/180 are available for the X type; 23 reduction ratios from 1/3 to 1/200 are available for the Z types.
- When the decimal gear head (reduction ratio: 1/10) is used, a reduction ratio of up to 1/1800 (1/2000 for the Y and Z types) can be attained.

Gear type

X : 40 W or smaller / Hinge not attached
 Z : 60 W or larger / Hinge not attached

• Hinge not attached

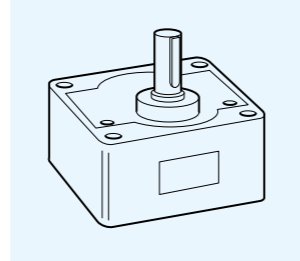

Gear type and reduction ratio list

Gear type	Motor capacity	Hinge	Reduction ratio																						
			1/3	1/3.6	1/5	1/6	1/7.5	1/9	1/10	1/12.5	1/15	1/18	1/20	1/25	1/30	1/36	1/50	1/60	1/75	1/90	1/100	1/120	1/150	1/180	1/200
X	40 W or smaller	Not attached	○	○	○	○	○	○	○	○	○	○	○	○	○	○	○	○	○	○	○	○	○	○	○
Z	60 W, 90 W	Not attached	○	○	○	○	○	○	○	○	○	○	○	○	○	○	○	○	○	○	○	○	○	○	○

Coding system

M **X** **9** **G** **30** **B** **U**

Output type Size Gear head Reduction ratio Bearing Inch sized gear head

- X : 40 W or smaller / Hinge not attached
Z : 60 W or larger / Hinge not attached
- 6 : 60 mm sq. (2.36 inch sq.)
7 : 70 mm sq. (2.76 inch sq.)
8 : 80 mm sq. (3.15 inch sq.)
9 : 90 mm sq. (3.54 inch sq.)
- (Example) 30: Reduction ratio of 1/30
- B : Ball bearing
- U : Inch sized gear head

* The motor and gear are sold separately.

* For details of gear head, refer to B-432-.

Type of gear head -inch (U.S.A.)

* Shown in □ is a gear ratio.

Model No.	Dimensions	Scale: 1/4, Unit: inch (mm)	Gear mounting screw Unit: inch (mm)
MX6G □ BU		Mass 0.24 kg (0.53 lb) [0.3 kg (0.66 lb)]	<ul style="list-style-type: none"> • Screw: M4 x 50 Cross recessed head screw4 • Flat washer for M44 • Hexagon nut: M44
MX7G □ BU		Mass 0.38 kg (0.84 lb) [0.45 kg (0.99 lb)]	<ul style="list-style-type: none"> • Screw: M5 x 55 Cross recessed head screw4 • Flat washer for M54 • Hexagon nut: M54
MX8G □ BU		Mass 0.6 kg (1.32 lb)	<ul style="list-style-type: none"> • Screw: M5 x 55 Cross recessed head screw4 • Flat washer for M54 • Hexagon nut: M54
MX9G □ BU		Mass 0.8 kg (1.76 lb)	<ul style="list-style-type: none"> • Screw: M6 x 65 Cross recessed head screw4 • Flat washer for M64 • Hexagon nut: M64
MZ9G □ BU		Mass 1.4 kg (3.09 lb)	<ul style="list-style-type: none"> • Screw: M6 x 85 hexagon socket head bolt4 • Flat washer for M64 • Hexagon nut: M64 • Key: one-end round1

(Note) Because the dimensions may be subject to change, also check the determinate dimensions if the gear head is to be used for design.

Induction motor
 Reversible motor
 3-phase motor
 Electromagnetic brake motor
 Variable speed induction motor
 Variable speed reversible motor
 Variable speed electromagnetic brake single-phase motor
 Variable speed unit motor
 C&B motor
 2-pole round shaft motor
 Gear head
 Gear head -inch (U.S.A.)

Gear head combination dimensions

Scale: 1/4, Unit: inch (mm)

Induction/ Reversible/ 3-phase motor (leadwire)

60 mm sq. (2.36 inch sq.) 6 W

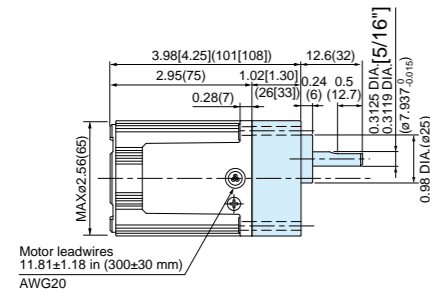

70 mm sq. (2.76 inch sq.) 15 W

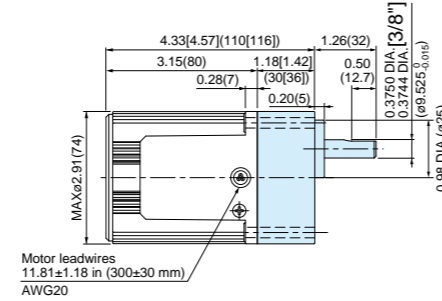

Note: The value in "[]" is for gear ratio of 1/30 or larger.

Note: The value in "[]" is for gear ratio of 1/30 or larger.

80 mm sq. (3.15 inch sq.) 25 W

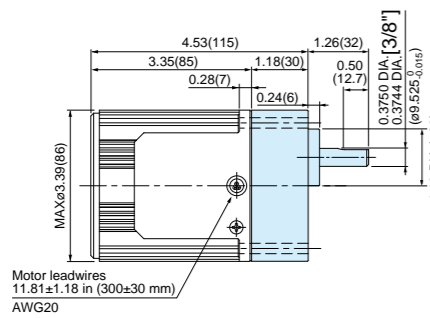

90 mm sq. (3.54 inch sq.) 40 W

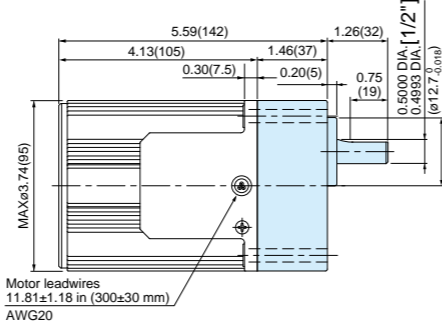

90 mm sq. (3.54 inch sq.) 60 W

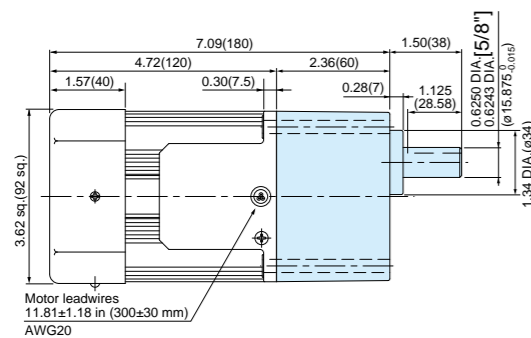

90 mm sq. (3.54 inch sq.) 90 W

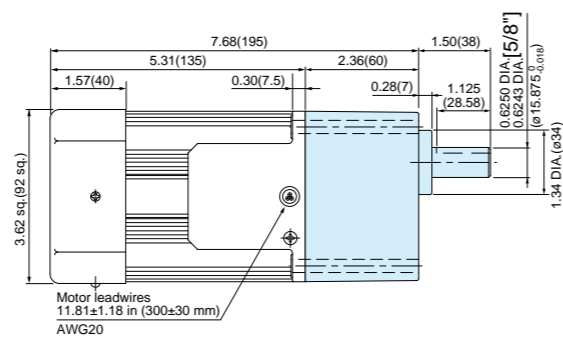

* 3-phase motor of 60 mm or 70 mm sq. is not available.

* Please read your User's manual carefully so that you will understand the operation and safety precautions before attempting to operate the system.

Induction/ Reversible/ 3-phase motor (sealed connector)

80 mm sq. (3.15 inch sq.) 25 W

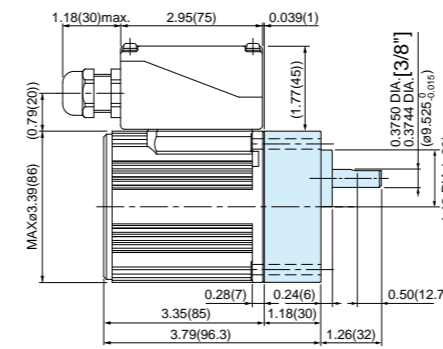

90 mm sq. (3.54 inch sq.) 40 W

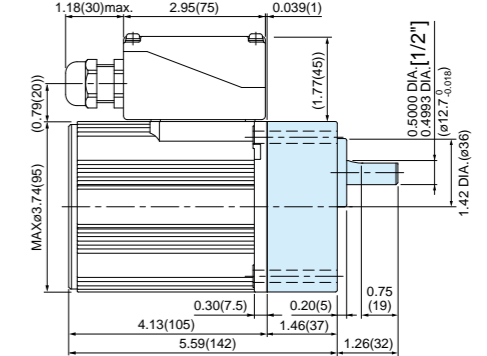

90 mm sq. (3.54 inch sq.) 60 W

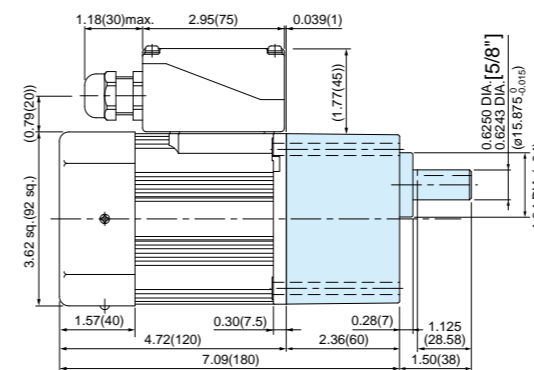

90 mm sq. (3.54 inch sq.) 90 W

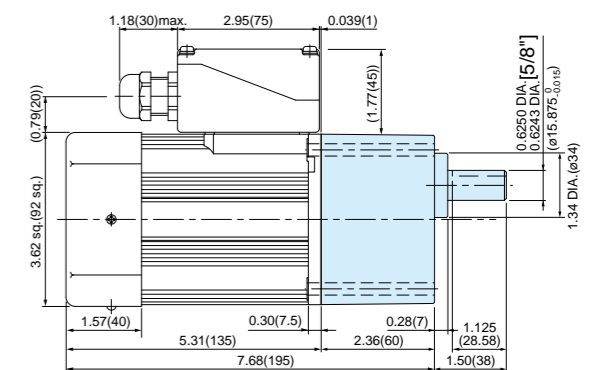

(Note) Because the dimensions may be subject to change, also check the determinate dimensions if the gear head is to be used for design.

Gear head combination dimensions

Scale: 1/4, Unit: inch (mm)

Electromagnetic brake motor (leadwire)

60 mm sq. (2.36 inch sq.) 6 W

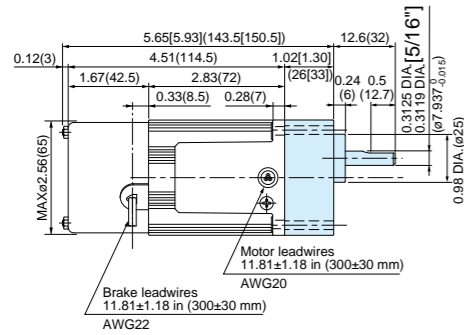

Note: The value in "[]" is for gear ratio of 1/30 or larger.

70 mm sq. (2.76 inch sq.) 15 W

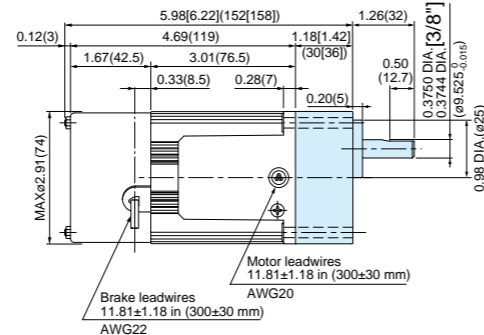

Note: The value in "[]" is for gear ratio of 1/30 or larger.

Variable speed induction/ reversible motor (leadwire)

60 mm sq. (2.36 inch sq.) 6 W

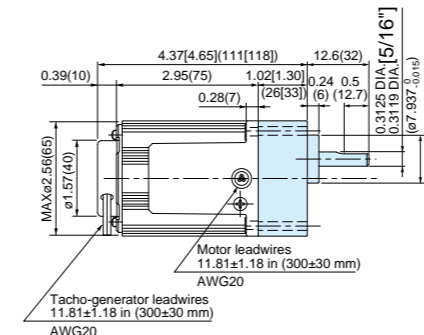

Note: The value in "[]" is for gear ratio of 1/30 or larger.

70 mm sq. (2.76 inch sq.) 15 W

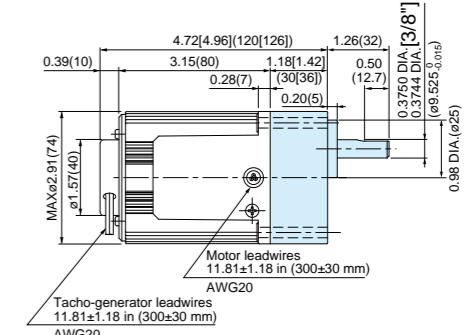

Note: The value in "[]" is for gear ratio of 1/30 or larger.

80 mm sq. (3.15 inch sq.) 25 W

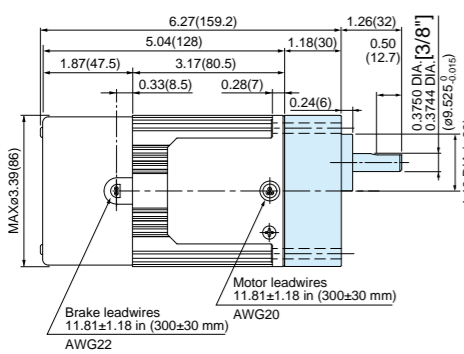

90 mm sq. (3.54 inch sq.) 40 W

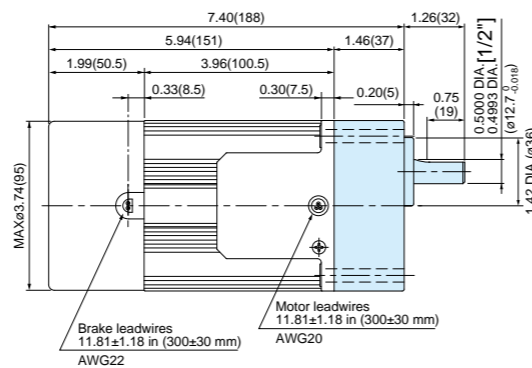

80 mm sq. (3.15 inch sq.) 25 W

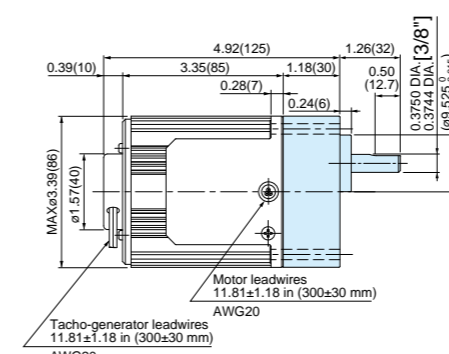

90 mm sq. (3.54 inch sq.) 40 W

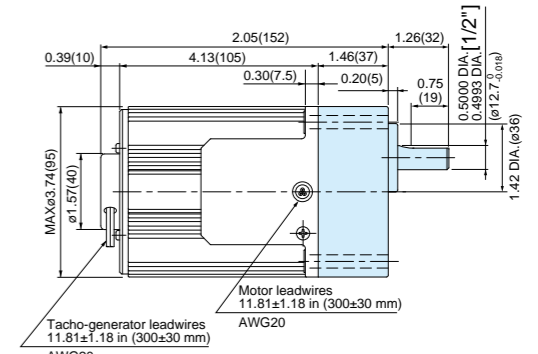

90 mm sq. (3.54 inch sq.) 60 W

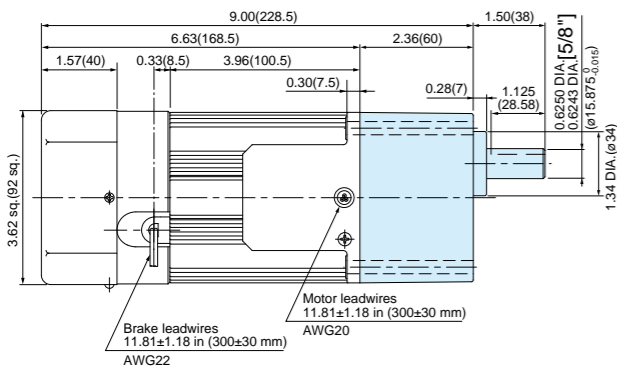

90 mm sq. (3.54 inch sq.) 90 W

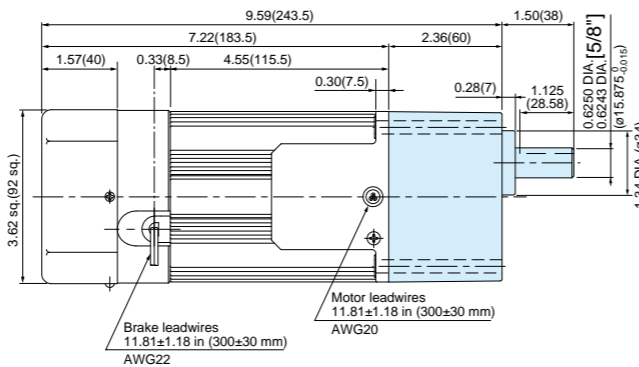

90 mm sq. (3.54 inch sq.) 60 W

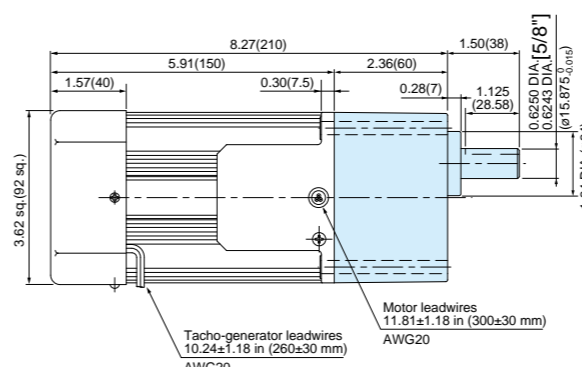

90 mm sq. (3.54 inch sq.) 90 W

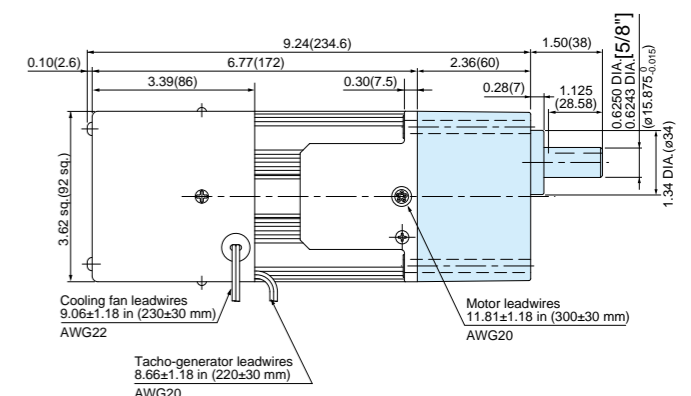

* Please read your User's manual carefully so that you will understand the operation and safety precautions before attempting to operate the system.

(Note) Because the dimensions may be subject to change, also check the determinate dimensions if the gear head is to be used for design.

Induction motor
Reversible motor
3-phase motor
Electromagnetic brake motor
Variable speed induction motor
Variable speed reversible motor
Variable speed electromagnetic brake single-phase motor
Variable speed unit motor
C&B motor
2-pole round shaft round
Gear head
Gear head - inch (U.S.A.)

