

Driver Integrated 5-Phase Stepping Motor

PKA Series

Built-in Controller Type

This is an all-in-one DC power supply input 5-phase stepping motor in which the driver and motor are integrated. This contributes to space saving and a reduction in the size of the customer's equipment.

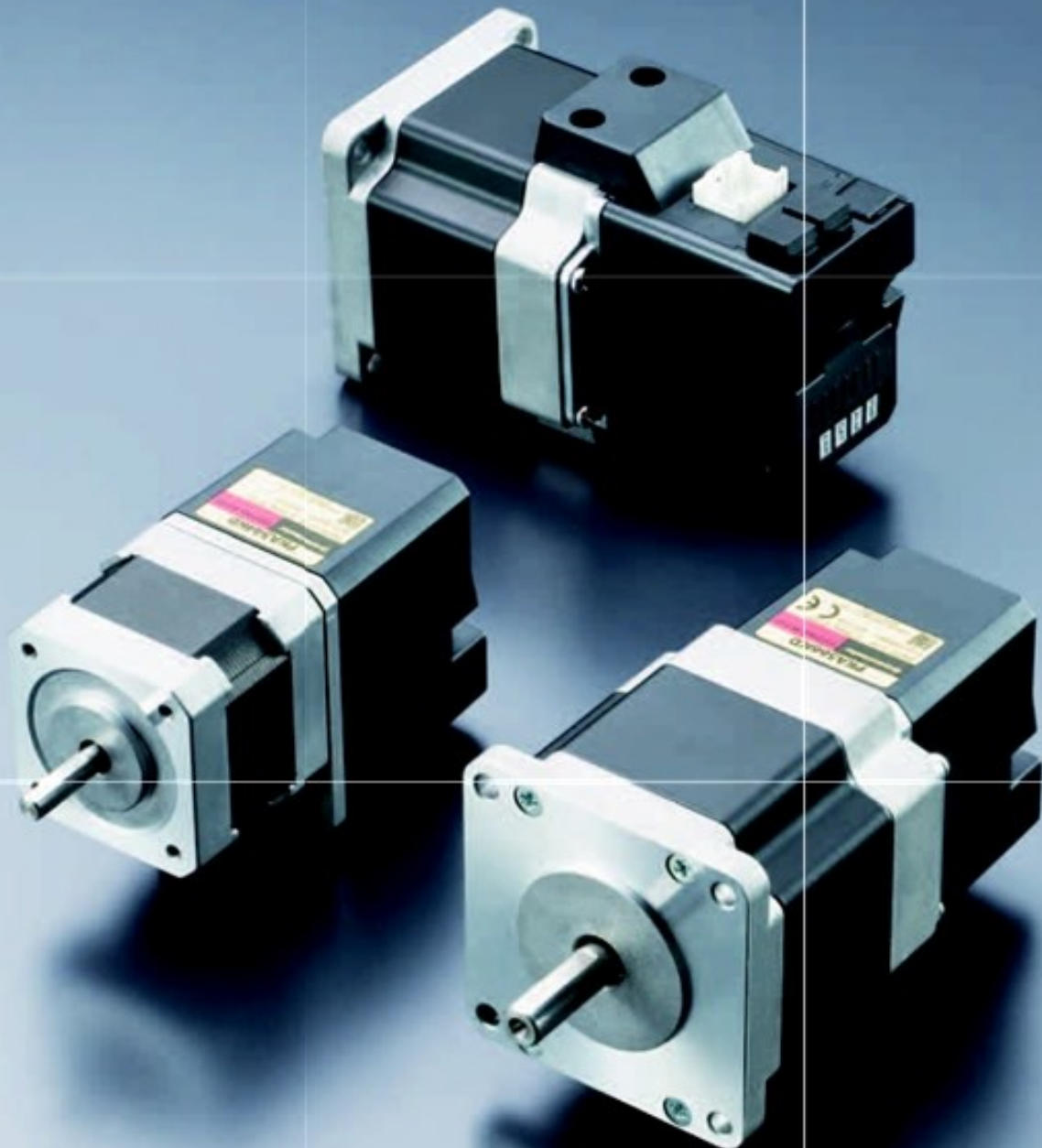

This is a DC input 5-phase stepping motor in which the driver and motor are integrated.

No wiring is needed between the driver and motor, contributing to space saving and a reduction in the size of the customer's equipment. It also reduces man hours required for wiring.

There are two methods of control that can be selected, including Modbus control.

Contributes to Space Saving and Reduced Wiring in the Equipment

The driver and the motor are integrated. Also, since there is a built-in positioning function, there is no need for a pulse generator. The system is simplified, contributing to space saving and a reduction in the size of the customer's equipment. It also requires less wiring.



Contributes to a Shorter Equipment Startup Time

Since no wiring is needed between the motor and driver or driver and pulse generator, wiring time is reduced. This also decreases the number of problems caused by wiring. All of this contributes to a shorter startup time for the customer's equipment.

- Motor + Driver + Pulse Generator

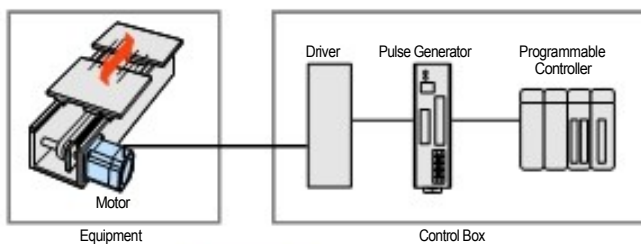

- PKA Series

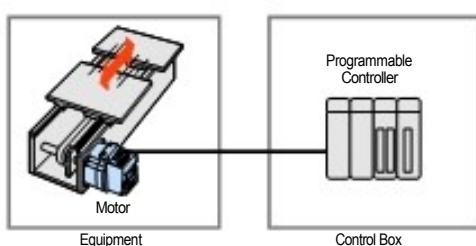

Two Control Method Options

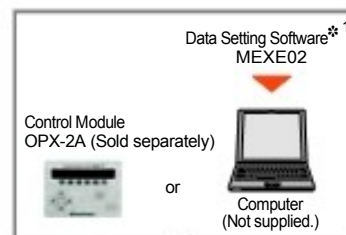

RS-485 communication

* 1 Data Setting Software MEXE02

Operating data settings, parameter changes, and monitoring are done on a computer.

Compatible software can be downloaded from the Oriental Motor website.

<http://www.orientalmotor.eu>

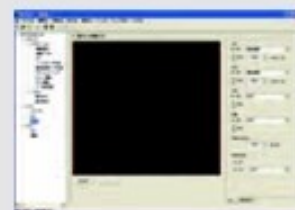

- Operating Status Waveform Monitoring



I/O Control



Programmable Controller

The function of a pulse generator is built in, letting you build an operation system by connecting directly to a programmable controller. Since no pulse generator is required, space is saved and the system is simplified.

Modbus Control

Computer



or



Programmable Controller

Operating data, parameter settings or operation commands can be input via RS-485 communication. A maximum of 31 motors can be connected to one programmable controller. Multi-axis simultaneous starting is also possible. The protocol is compatible with Modbus (RTU) and can be easily connected via a programmable controller, etc.

Reduces the Load on High-Order Programmable Controllers

A positioning function is built in, ensuring that the traveling amount, speed, and other operating data is retained in the motor. It is also equipped with a variety of other operation functions in addition to the positioning operation, such as continuous operation and a return-to-home operation. This contributes to a reduced load on the programmable controller, and a simplified program.

• Positioning Operation

The motor's operating speed and traveling amount are set in the operating data, and operations are performed in accordance with the selected operating data.

◇ Linked Operation

If the operating data is set to "linked", continuous positioning with the following data number is possible with one START signal.

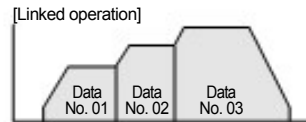

If data No. 01 is selected and START input, linked driving from data No. 01 to No. 03 is performed without the motor stopping.

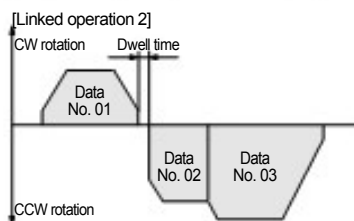

If data No. 01 is selected and START input, the data No. 01 operation is executed. After that, it is stopped for only the set dwell time* and then the operations from data No. 02 to No. 03 are executed. Operating data with a different rotation direction can also be linked.

* Dwell time is the wait time until the next positioning operation starts.

◇ Sequential Operation

If the operating data is set to "sequential positioning", positioning of the next data number is performed in sequence every time a START signal is input.

• Speed Control Operation

The motor operates continuously while a FWD signal or RVS signal is input. Because it operates at the speed of the operating data set beforehand, multistep speed-change operation is possible by changing the data number.

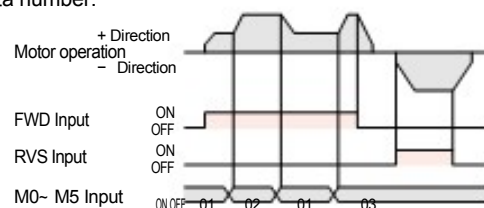

• Return-To-Home Operation

It is equipped with a return-to-home operation, so return-to-home can be done easily by wiring a sensor.

System Configuration

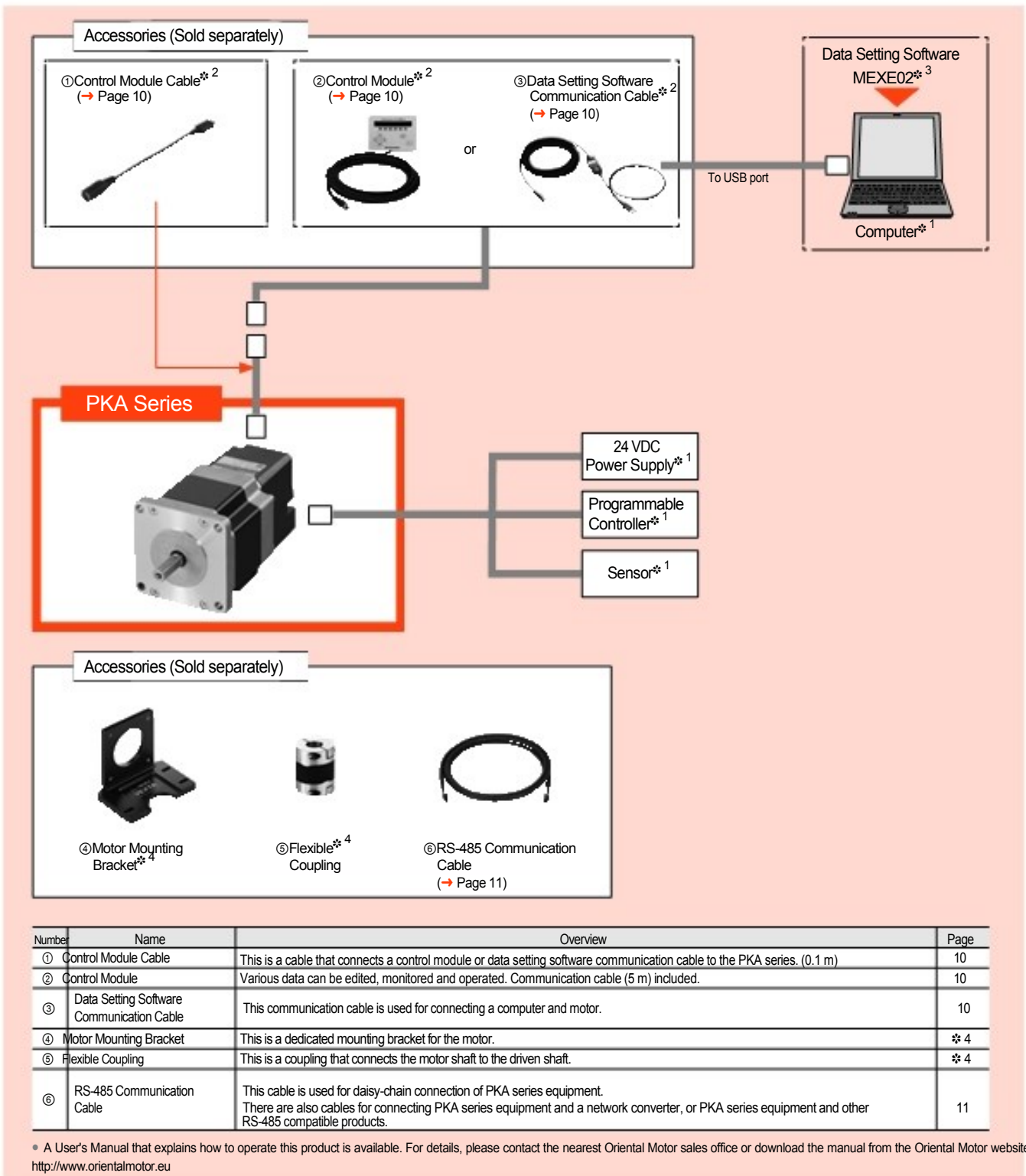

System Configuration Example



- * 1 Not supplied.
- * 2 This is required for driving I/O control.
- * 3 Compatible software can be downloaded from the Oriental Motor website. A CD-ROM is also distributed.
- * 4 For details, please contact the nearest Oriental Motor sales office.

The system configuration shown above is an example. Other combinations are also available.

Product Line

Product Name
PKA544KD
PKA566KD

Product Name	PKA544KD	PKA566KD
Max. Holding Torque	N·m 0.18	0.83
Holding Torque at Motor Standstill	N·m 0.09	0.41
Rotor Inertia	J·kg·m ² 54×10 ⁻⁷	280×10 ⁻⁷
Rated Current	A/Phase 0.75	1.4
Basic Step Angle	0.72°	
Power Supply Input	24 VDC±10% 1.4 A	24 VDC±10% 2.5 A
Excitation Mode	Microstep	

■ Speed - Torque Characteristics fs: Max. starting frequency

PKA544KD

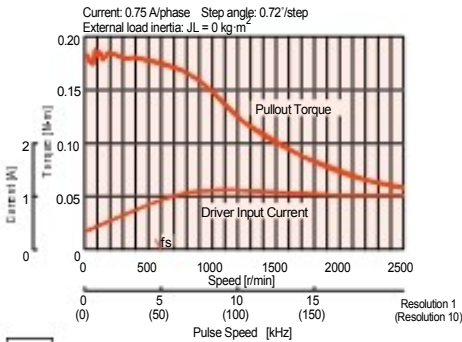

PKA566KD

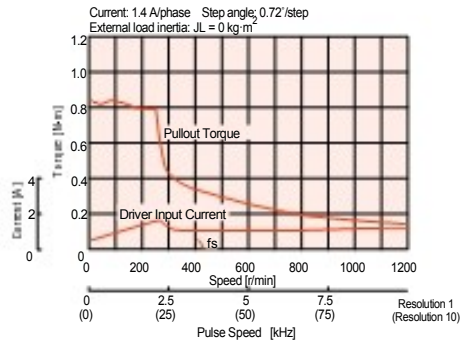

Note

• Depending on the driving conditions, a considerable amount of heat may be generated by the motor. Be sure to keep the motor case temperature at 75°C max.

■ Control Circuit Specifications

No. of Positioning Data Sets	64
Operation functions	Positioning Operation, Return-To-Home Operation, Continuous Operation, JOG Operation, Test Operation

■ Control Circuit RS-485 Communication Specification

Protocol	Modbus protocol (Modbus RTU mode)
Electrical Characteristics	EIA-485 compliance Twisted-pair wire (TIA/EIA-568B CAT5e or greater recommended) is used up to a total extension length of 50 m.
Transmission/Reception Mode	Half-duplex communication
Baud Rate	9600 bps/19200 bps/38400 bps/57600 bps/115200 bps
Physical Layer	Asynchronous mode (data: 8-bit, stop bit: 1-bit/2-bit, parity: none/odd/even)
Connection Type	Up to 31 units can be connected to one programmable controller (master equipment).

■ General Specifications

Specifications	Motor	
Heat-Resistant Class	130 (B)	
Insulation Resistance	The measured value is 100 MΩ min. when a 500 VDC megger is applied as follows under normal ambient temperature and humidity: · FG terminal and motor case — Between power input terminals	
Dielectric Strength	No abnormality is judged with the following application for 1 minute under normal ambient temperature and humidity: · FG terminal and motor case — Between power input terminals 500 VAC 50 Hz or 60 Hz	
Operating environment (In operation)	Ambient Temperature	0~ +50°C (non-freezing)
	Ambient Humidity	85% max. (non-condensing)
	Atmosphere	Use in an area without corrosive gases and dust. The product should not be exposed to water, oil or other liquids.
Degree of Protection	IP20	
Temperature Rise	Winding temperature rise is 80°C max. (measured by the resistance change method) at the rated current, at standstill, and 5-phases energized.	
Stop Position Accuracy*1	±3 arc minutes (±0.05°)	
Shaft Runout	0.05 T. I. R. (mm)*4	
Radial Play*2	0.025 mm max. of 5 N	
Axial Play*3	0.075 mm max. of 10 N	
Concentricity of Installing Pilot to the Shaft	0.075 T. I. R. (mm)*4	
Perpendicularity of Installation Surface to the Shaft	0.075 T. I. R. (mm)*4	

*1 This value is for full step under no load. (The value changes with the size of the load.)

*2 Radial Play: Displacement in shaft position in the radial direction when a 5 N load is applied in the vertical direction to the tip of the motor shaft.

*3 Axial Play: Displacement in shaft position in the axial direction when a 10 N load is applied to the motor shaft in the axial direction.

*4 T. I. R. (Total Indicator Reading): The total dial gauge reading when the measurement section is rotated one revolution centered on the reference axis center.

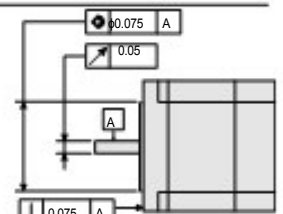

■ Permissible Overhung Load and Permissible Thrust Load

Unit = N

Motor Frame Size	Product Name	Max. Permissible Overhung Load Distance from Shaft End mm					Permissible Thrust Load
		0	5	10	15	20	
42 mm	PKA544KD	20	25	34	52	-	Motor
60 mm	PKA566KD	63	75	95	130	190	Self-Weight max.

■ Dimensions (Unit = mm)

● Motor

Frame Size 42 mm

Product Name	Mass kg
PKA544KD	0.37

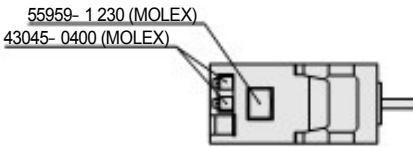
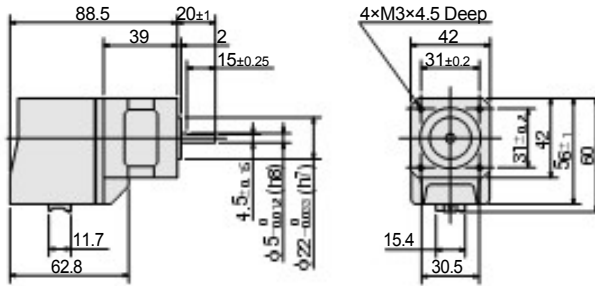

Frame Size 60 mm

Product Name	Mass kg
PKA566KD	0.89

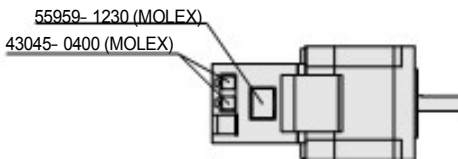
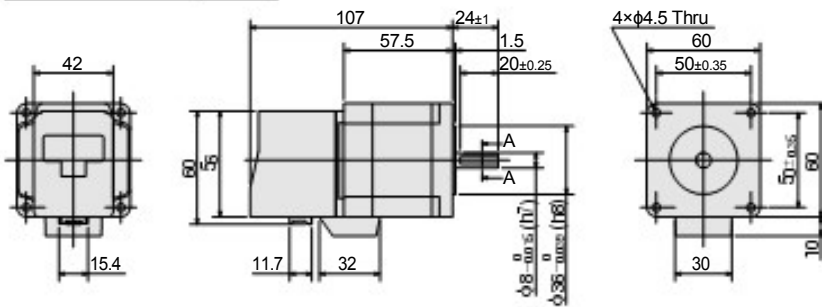

● Connection Cable (Included)

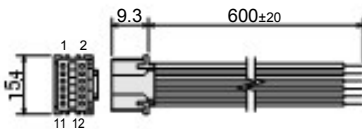

■ Connection and Operation

● Names and Function of Parts

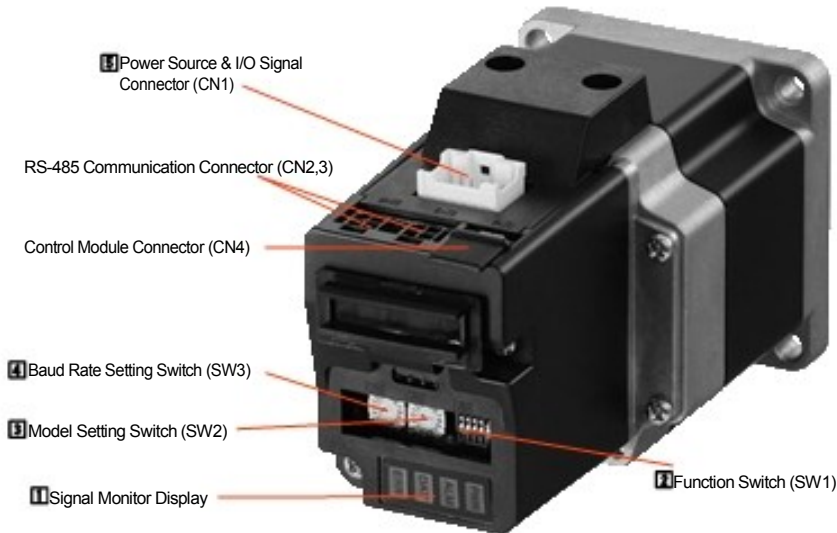

1 Signal Monitor Display

◇ LED Indicator

Indication	Color	Function	Lighting Condition
PWR	Green	Power Supply Indication	When the power supply is input
ALM	Red	Alarm Indication	When protective function is activated (blinking)
DAT	Green	Communication Indicator	When data is being received and sent
ERR	Red	Communication Error Indicator	When communication data is abnormal

2 Function Switch (SW1)

Indication	No.	Function
SW1	1,2	This sets the terminating resistance for RS-485 communication (120 Ω) (factory setting: OFF). OFF: No terminating resistance ON: Terminating resistance
	3	This sets the model number in combination with the model setting switch (SW2) (factory setting: OFF).
	4	This sets the protocol for RS-485 communication (factory setting: OFF).

◇ RS-485 Communication Protocol Setting

Destination No.	Network Converter Connection	Modbus RTU Mode
4	OFF	ON

3 Model Setting Switch (SW2)

Indication	Function
SW2	This is set during use with RS-485 communication. It sets the model number (factory setting: 0).

4 Baud Rate Setting Switch (SW3)

Indication	Function
SW3	This is set during use with RS-485 communication. It sets the baud rate (factory setting: 7).

◇ RS-485 Baud Rate Setting

No.	Baud Rate (bps)
0	9600
1	19200
2	38400
3	57600
4	115200
5~6	Not used
7	625000 (Network Converter Connection)
8~F	Not used

Power Source & I/O Signal Connector (CN1)

Indication	Pin No.	Signal Name	Content
CN1	1	FG	Frame Ground
	2	GND	Power Supply GND
	3	IN-COM	Input Common
	4	+24 VDC	+24 VDC Power Supply Input
	5	IN0	Control Input 0 (initial value: +LS)*
	6	IN1	Control Input 1 (initial value: - LS)*
	7	IN2	Control Input 2 (initial value: HOMES)*
	8	IN3	Control Input 3 (initial value: STOP)*
	9	OUT0+	Control Output 0 (initial value: ALM)*
	10	OUT0-	
	11	OUT1+	Control Output 1 (initial value: READY)*
	12	OUT1-	

* Assigned functions are set by means of the parameter settings. The above is the initial value. For details, refer to the User's Manual.

The following input signals can be assigned to input terminals IN0~ 3.

Input Signal					
0: Not used	8: MS0	18: STOP	36: R4	44: R12	52: M4
1: FWD	9: MS1	24: ALM-RST	37: R5	45: R13	53: M5
2: RVS	10: MS2	25: P-PRESET	38: R6	46: R14	60: +LS
3: HOME	11: MS3	27: HMI	39: R7	47: R15	61: - LS
4: START	12: MS4	32: R0	40: R8	48: M0	62: HOMES
5: SSTART	13: MS5	33: R1	41: R9	49: M1	63: SLIT
6: +JOG	16: FREE	34: R2	42: R10	50: M2	
7: - JOG	17: AWO	35: R3	43: R11	51: M3	

The following output signals can be assigned to output terminal OUT0~ 1.

Output Signal					
0: Not used	9: MS1_R	33: R1	42: R10	51: M3_R	67: READY
1: FWD_R	10: MS2_R	34: R2	43: R11	52: M4_R	68: MOVE
2: RVS_R	11: MS3_R	35: R3	44: R12	53: M5_R	70: HOME-P
3: HOME_R	12: MS4_R	36: R4	45: R13	60: +LS_R	72: TIM
4: START_R	13: MS5_R	37: R5	46: R14	61: - LS_R	73: AREA1
5: SSTART_R	16: FREE_R	38: R6	47: R15	62: HOMES_R	74: AREA2
6: +JOG_R	17: AWO_R	39: R7	48: M0_R	63: SLIT_R	75: AREA3
7: - JOG_R	18: STOP_R	40: R8	49: M1_R	65: ALM	80: S-BSY
8: MS0_R	32: R0	41: R9	50: M2_R	66: WNG	

• Connection Diagram

◇ Connection to Programmable Controller

• Example of Connection with Current Sink Output Circuit (PNP specification)

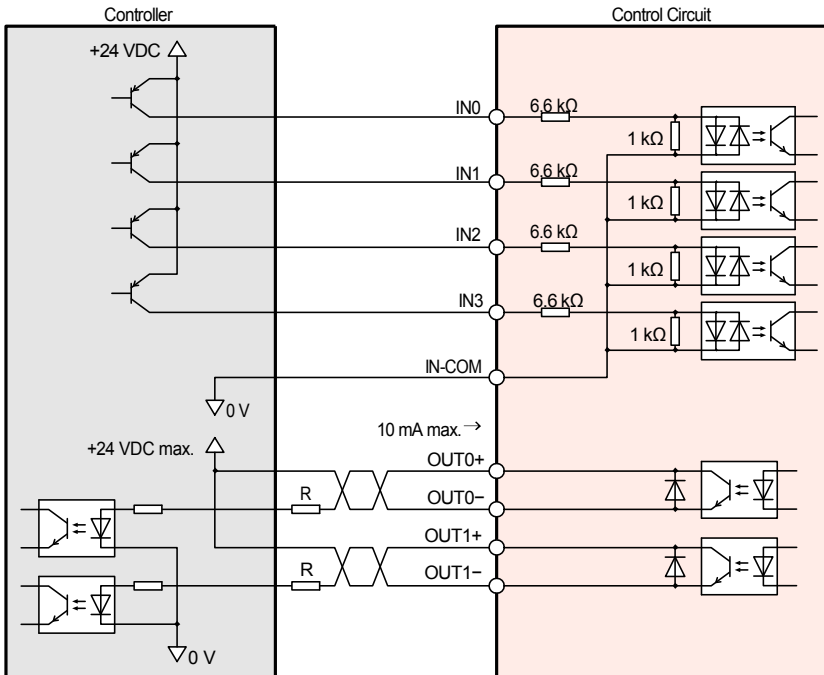

• Example of Connection with Current Sink Output Circuit (NPN specification)

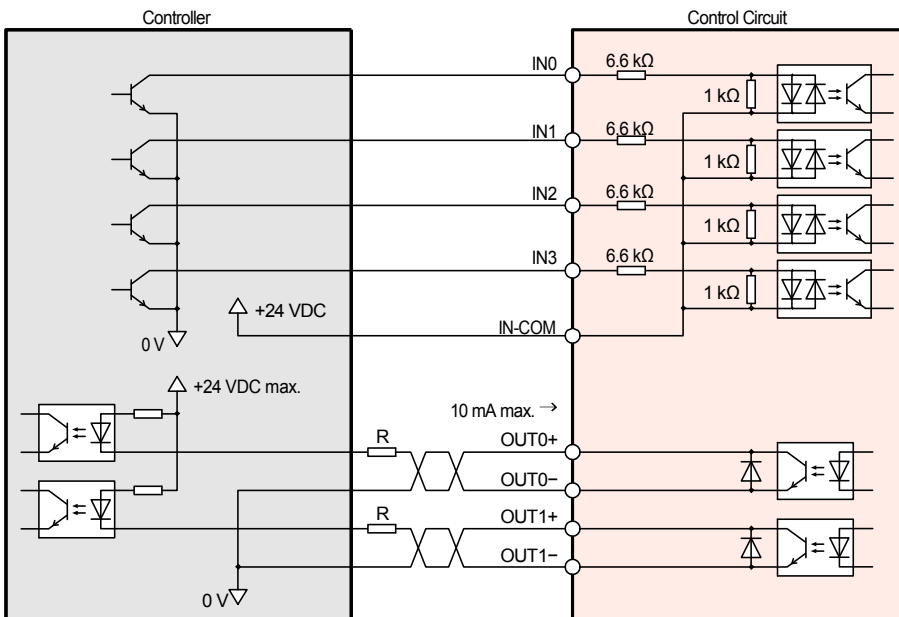

Note

- Please use 24 VDC for the input signal.
- Please use 24 VDC 10 mA max. for the input signal. When the current value exceeds 10 mA, connect the external resistor R to keep the current 10 mA max. • If noise generated by the power supply cable causes a problem with the specific wiring or layout, shield the cable or use ferrite cores.

Accessories (Sold separately)

These accessories are needed to change parameter settings, data settings, etc. in the PKA Series.

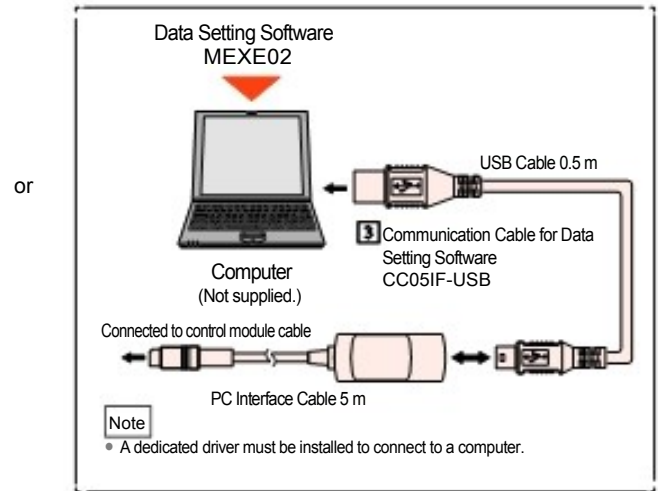
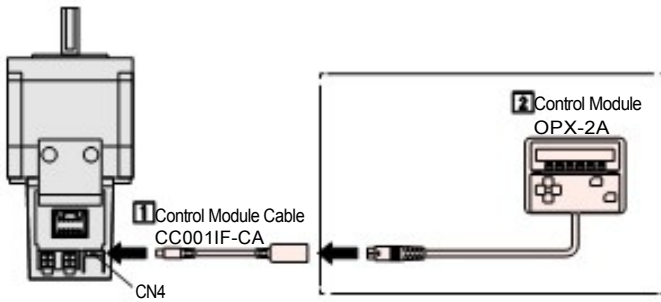

1 Control Module Cable

This is a cable that connects an OPX-2A or data setting software communication cable to the PKA Series.

Product Line

Product Name
CC0011F-CA

Dimensions

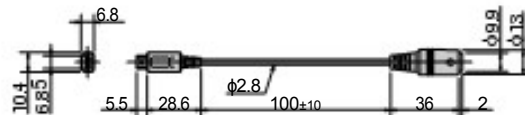

2 Control Module

Changes can be made to parameter settings, data settings, etc. It can also be used for speed and I/O monitoring, teaching, etc.

Product Line

Product Name
OPX-2A

Specifications

Indication	LED
Cable Length	5 m
Operating Ambient Temperature	0~ +40°C (non-freezing)



Dimensions (Unit = mm)

Control Module

Mass: 0.25 kg

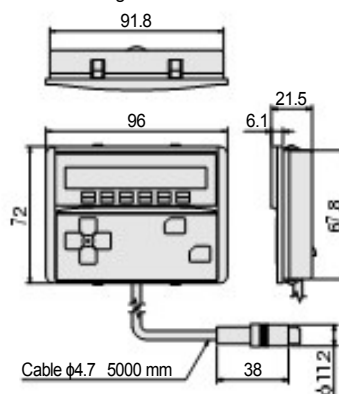

Installation Hole Dimensions

(Installation Plate Thickness 1~ 3 mm)

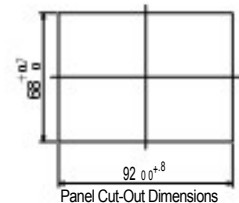

3 Communication Cable for Data Setting Software

This communication cable is used for connecting a computer and motor.

Product Line

Product Name
CC051F-USB



■ Data Setting Software MEXE02

Data setting software can be downloaded from the Oriental Motor website.

<http://www.orientalmotor.eu>

A CD-ROM is also distributed.

For details, please go to the Oriental Motor website or contact the nearest Oriental Motor sales office.

■ Operating Environment

● Operating System (OS)

- Microsoft Windows 2000 Professional Service Pack 4
Be sure to use the Rollup1 provided by Microsoft Corporation.
Check "Program Additions and Deletions" to see if Rollup1 is used.

The following OS are only compatible with 32-bit (x86) and 64-bit (x64) versions.

- Microsoft Windows XP Home Edition Service Pack 3
- Microsoft Windows XP Professional Service Pack 2
- Microsoft Windows XP Professional Service Pack 3*¹
- Microsoft Windows Vista Home Basic Service Pack 2
- Microsoft Windows Vista Home Premium Service Pack 2
- Microsoft Windows Vista Business Service Pack 2
- Microsoft Windows Vista Ultimate Service Pack 2
- Microsoft Windows Vista Enterprise Service Pack 2
- Microsoft Windows 7 Starter Service Pack 1
- Microsoft Windows 7 Home Premium Service Pack 1
- Microsoft Windows 7 Professional Service Pack 1
- Microsoft Windows 7 Ultimate Service Pack 1
- Microsoft Windows 7 Enterprise Service Pack 1

* 1 32-bit (x86) version only

● PC

Recommended CPU* ²	Intel Core processor 2 GHz min. (Compatible with OS)
Display	Video Adapter and Monitor with Resolution of XGA (1024 × 768) min.
Recommended Memory* ²	32-bit version (x86): 1 GB min. 64-bit version (x64): 2 GB min.
Hard Disk* ³	Free disk space of 30 MB min.
USB Port	USB 1.1 1 Port
Disk Device	CD-ROM Drive (Used for installation)

*² The operating conditions of the OS must be met.

*³ MEXE02 requires Microsoft .NET Framework 2.0 Service Pack 2. It will be automatically installed if it is not already installed, so 500 MB max. of free space may be required.

Note

- Depending on the system environment used by the customer, the required memory and hard disk space may vary.
- Windows and Windows Vista are registered trademarks of Microsoft Corporation in the United States and other countries.

RS-485 Communication Cable

This is an RS-485 communication cable.



CC020-RS4A

■ Product Line

Product Name	Overview	Length m
CC020-RS4A	This cable is used for daisy-chain connection of PKA Series equipment.	2

■ Dimensions

CC020-RS4A

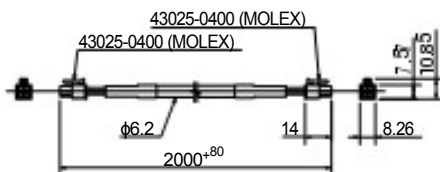

● Connection Example

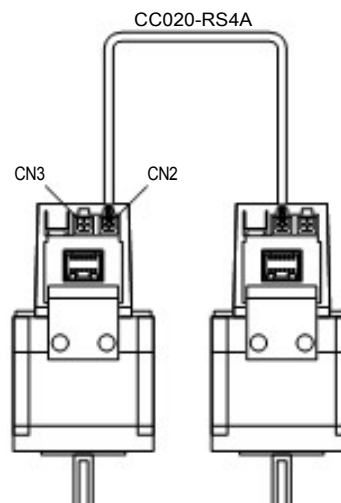

This product is manufactured at a plant certified with the international standards ISO 9001 (for quality assurance) and ISO 14001 (for systems of environmental management).

Specifications are subject to change without notice.
This catalogue was published in October, 2012.

Orientalmotor

ORIENTAL MOTOR (EUROPA) GmbH

www.orientalmotor.de

European Headquarters and Düsseldorf Office
Schiebsstraße 74
40549 Düsseldorf, Germany
Tel: 0211-5206700 Fax: 0211-52067099

Munich Office

Carl-von-Linde-Straße 42
85716 Unterschleißheim, Germany
Tel: 089-318122500 Fax: 089-318122525

Hamburg Office

Meckelfelder Weg 2
21079 Hamburg, Germany
Tel: 040-76910443 Fax: 040-76910445

Jena Office

Wildenbruchstraße 15
07745 Jena, Germany
Tel: 03641-675280 Fax: 03641-675288

Frankfurt Office

Kruppstraße 105
60388 Frankfurt, Germany
Tel: 069-40149780 Fax: 069-40149782

Stuttgart Office

Tel: 07335-924853 Fax: 07335-924854

ORIENTAL MOTOR (UK) LTD.

www.oriental-motor.co.uk

UK Headquarters

Unit 5, Faraday Office Park,
Rankine Road, Basingstoke,
Hampshire RG24 8AH U.K.
Tel: 01256-347090 Fax: 01256-347099

Birmingham Office

Suite 45
Plato Close, Tachbrook Park
Leamington Spa CV34 6WE, U.K.
Tel: 01926-671220 Fax: 01256-347099

ORIENTAL MOTOR (FRANCE) SARL

www.orientalmotor.fr

France Headquarters

56, Rue-des Hautes Pâtures
9200 Nanterre Cedex, France
Tel: 01 47 86 97 50 Fax: 01 47 82 45 16

Lyon Office

10, Allée des Sorbiers
69673 Bron Cedex, France
Tel: 04 78 41 15 02 Fax: 04 78 41 15 90

ORIENTAL MOTOR ITALIA s.r.l.

www.orientalmotor.it

Italy Headquarters

Via A. De Gasperi, 85
20017 Mazzo di Rho (MI), Italy
Tel: 02-93906346 Fax: 02-93906348

Bologna Office

Via mori, 6
40054 Prunaro di Budrio (BO), Italy
Tel: 051-6931249 Fax: 051-6929266

Verona Office

Piazza Roma, 3A
37066 Sommacampagna (VR), Italy
Tel: 045-8961049 Fax: 045-8971978

ORIENTAL MOTOR CO., LTD.

www.orientalmotor.co.jp

Headquarters

4-8-1 Higashiueno
Taito-ku, Tokyo 110-8536, Japan
Tel: (03)6744-0361 Fax: (03)5826-2576

For more information please contact: