

Orientalmotor

Stepper Motor and Driver Package α STEP

AZ Series

Equipped with Battery-Free Absolute Sensor



ADVANCED PERFORMANCE

Absolute × Battery-Free Brings advanced POSITIONING close to hand.

The new **AZ** Series line-up achieves absolute positioning without the need for a battery.

As a battery is not needed this contributes to a reduction in total cost.

So the **AZ** Series offers absolute positioning for an affordable price.

*See page 12 for details on the lineup.



HPG Geared Type



PS Geared Type



□20 mm



□28 mm



□42 mm

Stepper Motor and Driver Package α STEP

AZ Series

Equipped with Battery-Free Absolute Sensor

■ Lineup

Standard Options

□20 mm/□28 mm/□85 mm

Geared Options with Electromagnetic Brake

□42 mm/□60 mm/□90 mm



TS Geared Type



Harmonic Geared Type



□60 mm



□85 mm

ADVANCED
PERFORMANCE

Equipped with a newly developed ABZO sensor, this is advanced technology at an affordable price.

Newly developed **ABZO** sensor

We have developed a compact, low cost, battery-free mechanical absolute sensor (patented). This affordable motor series allows for productivity improvements and cost reductions.



● Mechanical Sensor

Analog clocks measure the current time based on the positions of the second hand, minute hand and hour hand. ABZO sensor is a mechanical sensor equipped with multiple gears equivalent to the hands on a clock. As it detects positioning information by detecting the angles of the respective gears, a battery is not required.

● Multirotation Absolute System

Absolute position detection is possible with ± 900 rotations (1800 rotations)* of the motor shaft from the home position.

* The frame sizes 20 and 28 mm are ± 450 rotations (900 rotations).

● Home Position Setting

By pressing the switch on the driver surface home position can be set simply, and the home position can be saved with the ABZO sensor. Furthermore, it is possible to set the home position using the data setting software (**MEXE02**) or the external input signal.

·Basic principles are like an analog clock

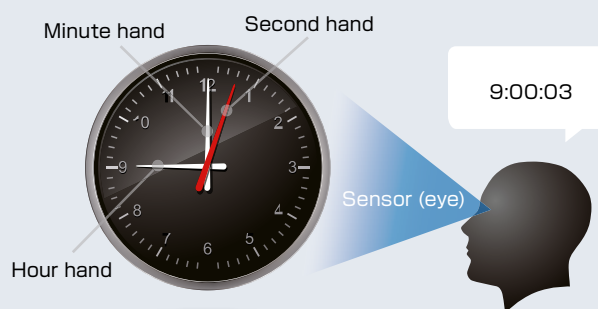

·Home Position Setting

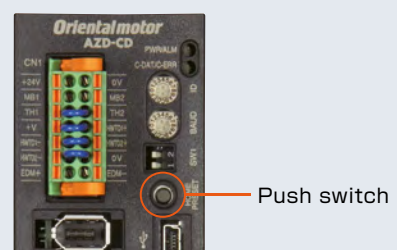

External Sensors Not Required

As it is an absolute system, external sensors such as the home sensor or limit sensor are not required.

● High Speed Return-to-Home + Improved Return-to-Home Accuracy

Because return-to-home is possible without using an external sensor, return-to-home can be performed at high speed without taking the sensor sensitivity into account, allowing for a shortened machine cycle. Furthermore, as return-to-home can be performed without concern for differences in the home sensor, it is possible to improve home position accuracy.

Pre-ABZO homing method example

The home position is detected at low speed by detecting the limit sensor (\pm LS) and home sensor (HOME).

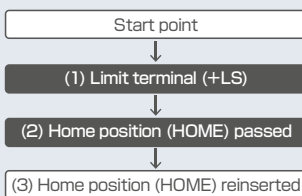
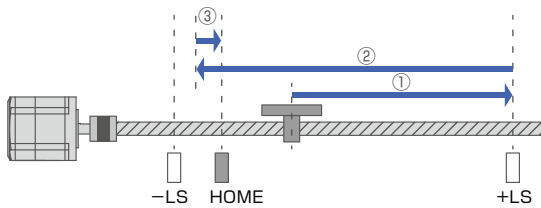

Return-to-home takes time ...



AZ Series utilising ABZO sensor homing method

There is no need to detect the limit sensor, and it moves directly at high speed to the home position recorded by the ABZO sensor.

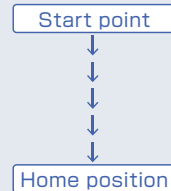
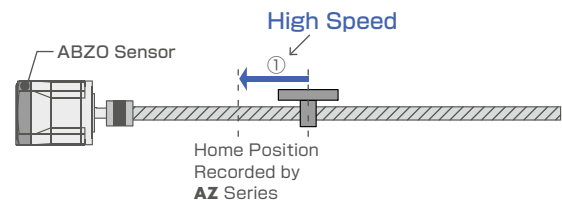

Through high speed return-to-home, machine cycle can be shortened!



● Cost reductions

Sensor costs and cable costs can be reduced, leading to lower system costs.

● Cable savings

This reduces cabling, increasing device design degree of freedom.

● Not affected by sensor

The **AZ** Series eliminates concerns such as sensor malfunctions, sensor faults or disconnection of the sensor lines. For example, sensor malfunctions due to metal flakes or oil mist floating about in the environment will be prevented.

● In systems where limit switches are not possible, software limits can be used to prevent the limit values being exceeded.

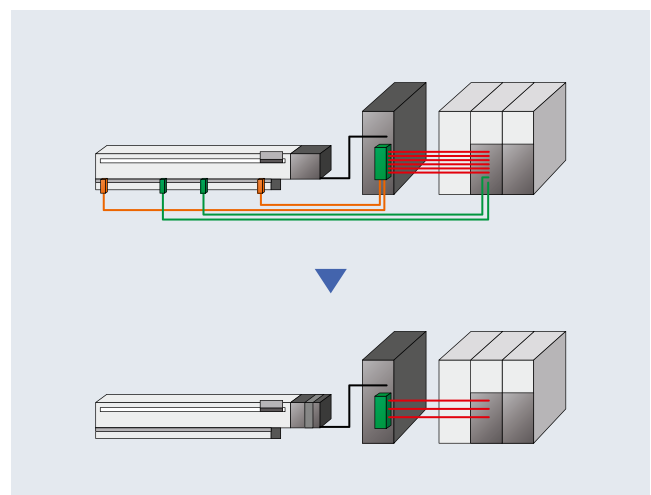

Achieves a Battery-Free Absolute System.

Battery-Free ABZO Sensor

As this is a mechanical sensor, a battery is not necessary. The positioning information is managed mechanically by the ABZO sensor.



● Maintaining Positioning Information

Even if the power shuts down during a positioning operation, the positioning information is retained. Furthermore, for built-in controller types, positioning operations can restart without performing a return-to-home operation when recovering from an emergency stop of the production line or a power cut.

● If the motor is temporarily replaced it is necessary to reset the home position as the positioning information is stored in the ABZO sensor.

Built-in Controller Type

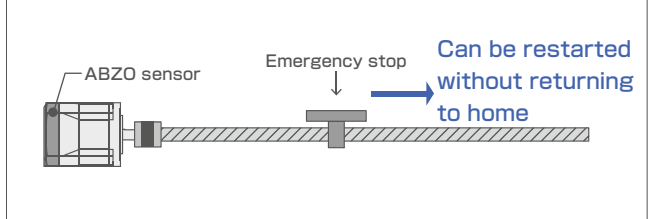

● Reduction in Maintenance

There is no need to replace the battery, so the effort and cost of maintenance is reduced.

● Drivers take up less Space

As space is not required for the battery, this frees up space within the panel for other purposes.

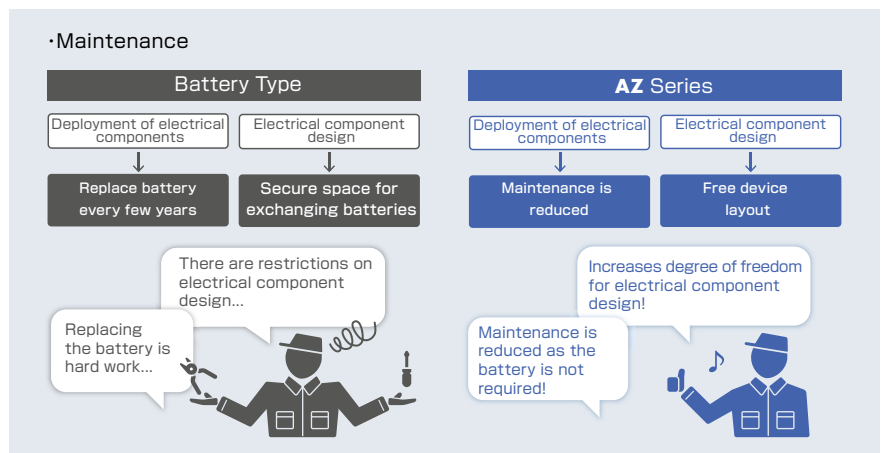

● Safe for Overseas Shipping

As normal batteries are self discharging, care is required when transporting the device over long periods, such as in the case of overseas shipments. ABZO sensors do not require batteries, so there is no deadline for the storage of positioning information. Furthermore, there is no need to consider the respective regulations etc. when exporting overseas.

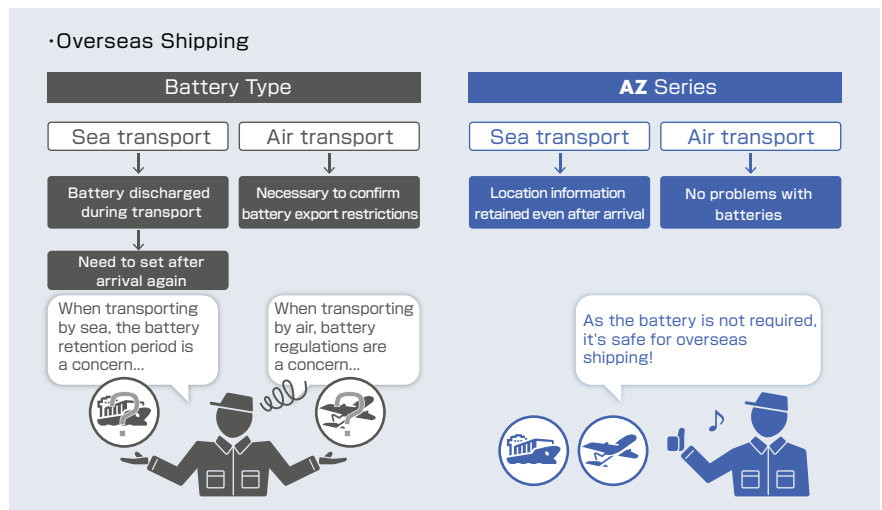

Save Energy with High Reliability and High Efficiency of α STEP



High Reliability

We have adopted a proprietary control system.

We have achieved high reliability by linking the benefits of open loop control and closed loop control.

- **Keeps driving even in the case of sudden load changes or sudden acceleration**

Normally it drives with open loop control in sync with the pulse commands. At times of overload, control instantly switches to control using a closed loop, and perform positioning correction.

- **Tuning not required**

As normally it drives with open loop control, when there is a change in load, such as in the belt mechanism, cam and chain drive, the positioning can be determined without gain adjustment.

- **Outputs an alarm signal in case an abnormality occurs**

When overload continuously occurs, an alarm signal is output and when positioning determination is complete, a signal is output. This supports high reliability.

- **Storing of stop position**

When determining positioning, it stops using the motor's own holding torque without hunting. Therefore it is suitable for use in a situation where vibration could cause a problem when stopping due to a low-rigidity mechanism.

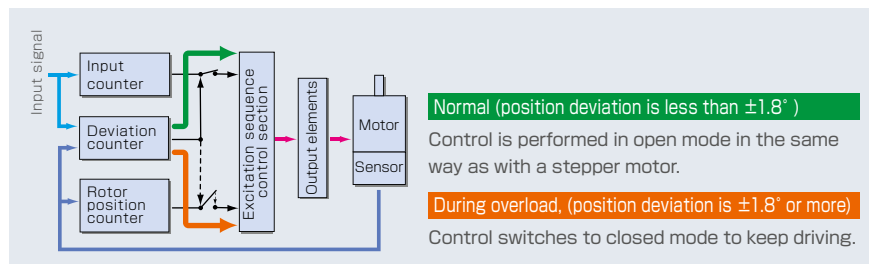

Energy Saving

Energy saving is also achieved by reducing motor heat generation through high efficiency.

- **Reduced heat generation**

We have achieved a significant decrease in heat generation through high efficiency.

- **The amount of power consumption has been reduced to 47% of its previous levels through energy saving**

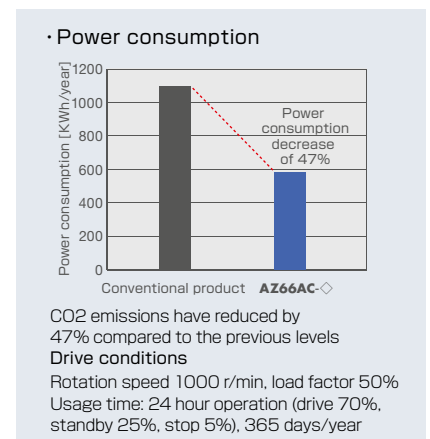
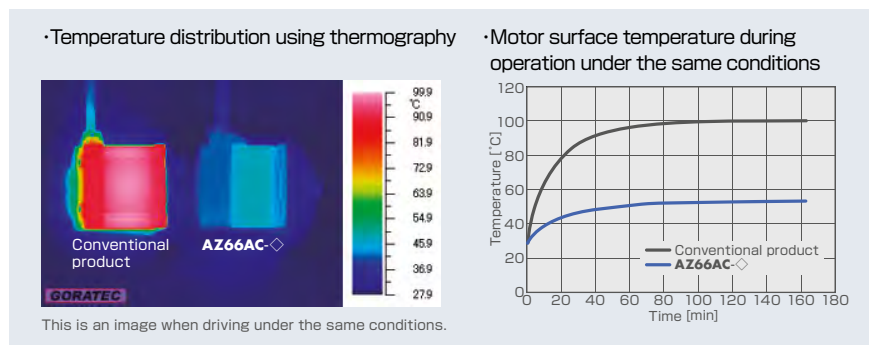

Four drivers that can be chosen based on the master control system.



NEW Pulse-Input Type with RS-485 Communication AC DC

This type executes operations by inputting pulses into the driver. It controls the motor using a pulse generator. By using RS-485 communication motor status information (position, speed, torque, alarm, temperature, etc.) can be monitored.

Basic Settings (setting when shipped)

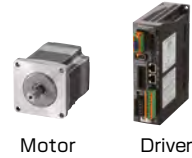

Operating Data Settings
Parameter Settings
Data setting software **MEXE02**

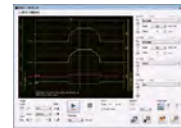

By using the MEXE02 data setting software, the alarm history can be displayed and a variety of monitoring can be customized according to the customer's needs.

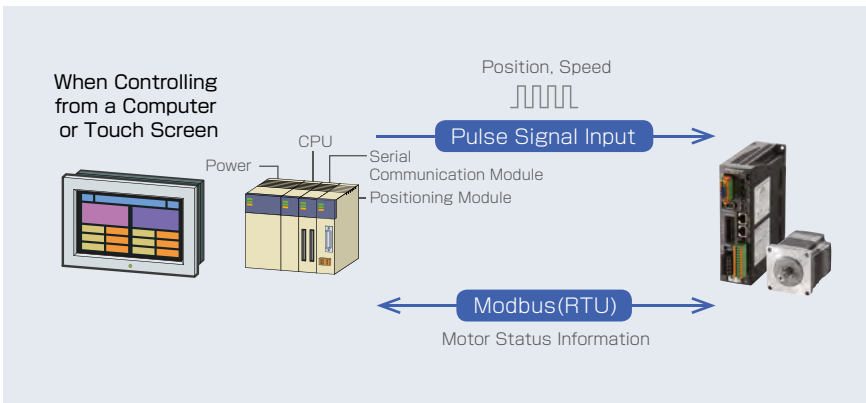

Built-in Controller Type FLEX AC DC

The built-in controller type driver allows for up-to 256 items of operating data, such as motor speed, position, acceleration / deceleration, interrupts, etc to be executed by a master controller via (1) I/O, (2) Modbus (RTU)/RS-485 or (3) FA network.

Basic Settings (setting when shipped)

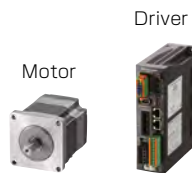

Operating Data Settings
Parameter Changes

Data setting software (**MEXE02**)

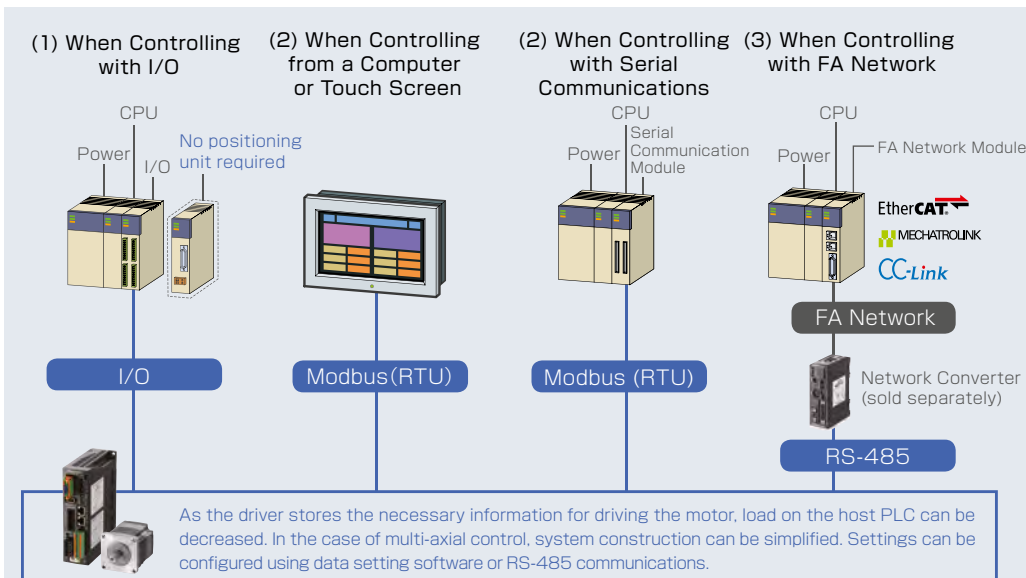
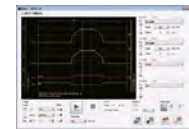

Alternatively this can be set using RS-485 communications.

Through the use of network converters (sold separately), EtherCAT, CC Link and MECHATROLINK communications are supported. Through the available communication protocols it is possible to set the operating data, parameters, and operating commands, allowing for shorter design and build times.

● EtherCAT is a registered trademark for which a license is provided by Beckhoff Automation GmbH in Germany.
● CC-Link is a registered trademark of CC-Link Partner Association and MECHATROLINK is a registered trademark of MECHATROLINK Members Association.

Pulse-Input Type

AC

DC

The pulse-input type driver is driven by a pulse and direction input from a host PLC. Motion control is carried out via a pulse generator; an add on module to the PLC which must be prepared by the customer.

Basic Settings
(setting when shipped)

Motor



Driver



By using the data setting software (**MEXE02**), it is possible to confirm alarm history and monitor the various states.

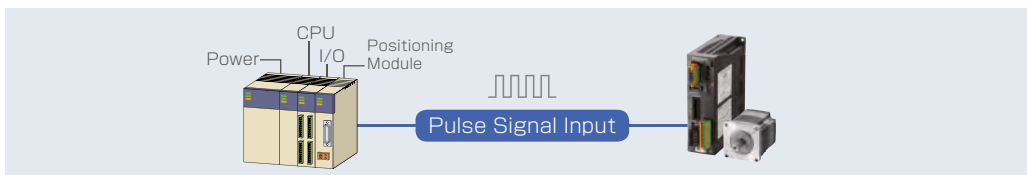

● Data setting software (**MEXE02**) can be downloaded from the website.

NEW

Network Compliant Multi-Axis Driver

DC

This multi-axis driver is corresponding to EtherCAT drive profiles.

It can be connected to **AZ** Series DC input motors and to linear actuators equipped with those motors.

Drivers for 2 axes, 3 axes and 4 axes are available.

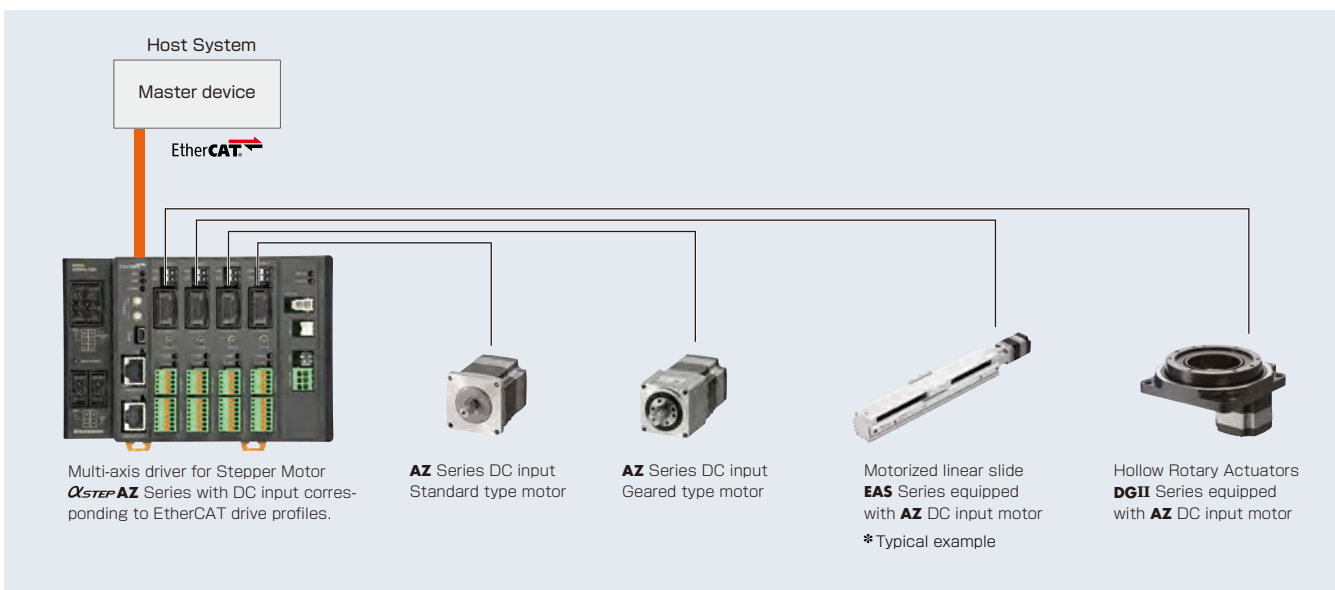

● EtherCAT is registered trademark and patented technology, licensed by Beckhoff Automation GmbH, Germany.

● Data setting software (**MEXE02**) can be downloaded from the website.

Simple Settings and Usable Functions that could not be realized without **AZ**



Data setting software **MEXE02**

Data setting software can be downloaded from the website.

Simple Settings/Easy Operations

By using the **MEXE02** software it is possible to adjust the motor configuration and edit multiple operating and parameter settings. Furthermore, the built-in controller is able to carry out sequential control from multiple inputs or predefined interrupts without requiring a master controller.

● Unit-type setting wizard

The units wizard is a function which allows the engineer to input the units they wish to work with. Thereby reducing the burden of converting units when inputting operational data.



● A simple system can be realised without a master controller.

The built-in controller type driver can set and execute independently up-to 256 items of operating data, such as motor speed and index length. Furthermore, with sequential control it is possible to form a simple system without a master controller. This is ideal for index and return operations or aligned transportation, such as lifetime / durability tests.

In case of questions please use our free hotline:
00800 22 55 66 22

Test Functions

Function for driving the motor independently and with which it is possible to connect with the master control system. By using during device startup, this can help to save time.

● Teaching Remote Operation At startup

It is possible to simply set home positions and drive the motor from the data setting software. Before connecting to the master control system, as it can perform teaching and test operations, this contributes to saving time for device startup.

● I/O Test At startup When driving

You can perform input signal monitoring and output signal forced output. This is a convenient function for confirming hard wiring with the master control system and the network I/O operation.

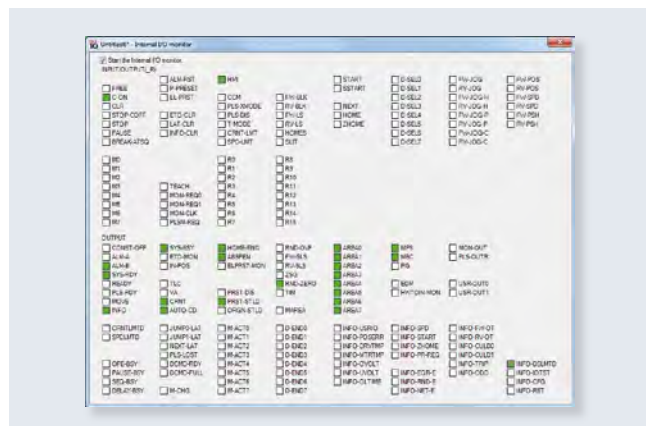
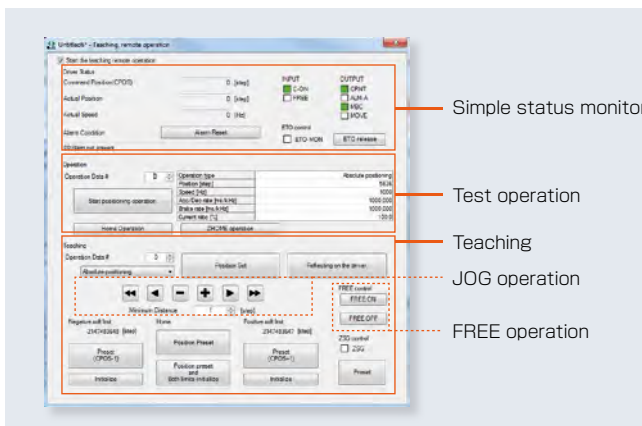

Monitor Function

Excellent monitor functions are included in order to confirm the motor driving state. Using differently based on the various scenarios helps with device startup, shortening of adjustment time and efficient maintenance.

● Waveform Monitoring At startup

It is possible to monitor the motor driving state and output signal state in the same way as with an oscilloscope. Use this when starting up or adjusting the device.



● Alarm Monitoring When driving During maintenance

When an abnormality occurred, it is possible to confirm the content of the abnormality, driving state when it occurred, and countermeasure methods. As the countermeasure method can be confirmed, the abnormality can be handled smoothly.

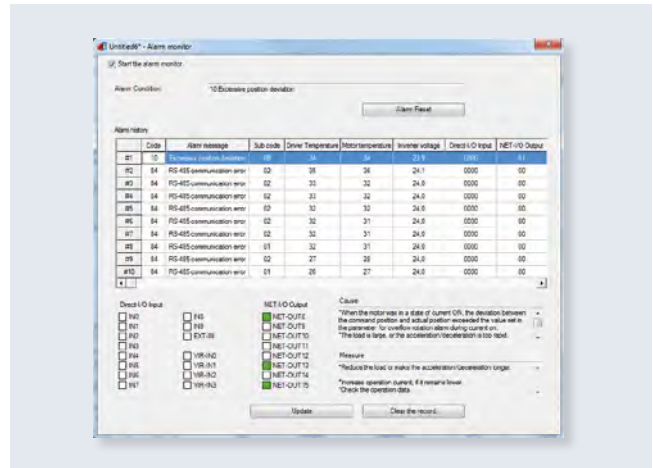

● Status Monitoring When driving During maintenance

When driving, it is possible to monitor speed, motor/driver temperature and load rate, as well as total revolutions from start of use. For the various items, as it is possible to set any signal to output, this is effective for efficient maintenance.

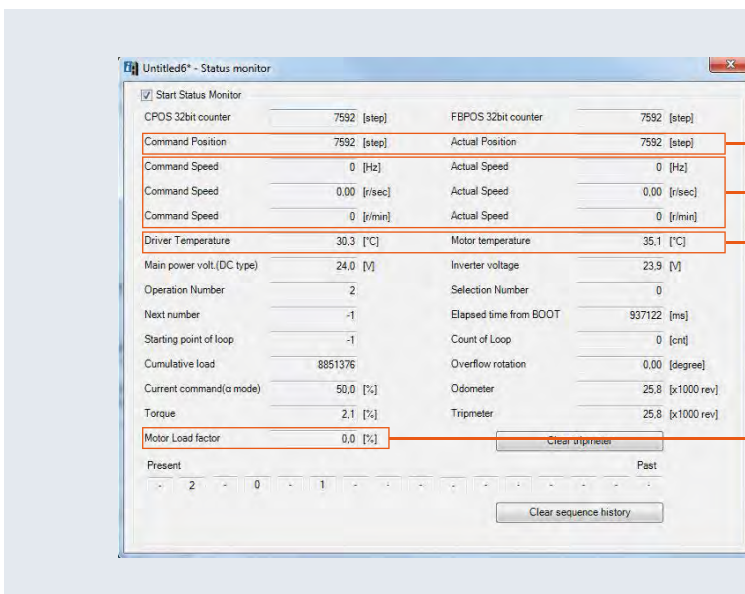

The actual position is detected in relation to the command position.

The actual speed is detected in relation to the command speed.

Detects the temperature within the motor encoder part and driver.

Displays the current load rate, given that the output torque for the speed during rotation is 100%.

Lineup

Motor

AC Single-Phase 200-240 VAC

DC 24/48 VDC

Type	Electro-magnetic Brake	Frame Size [mm]				
		20	28 ^{*6}	42 ^{*2}	60	85/90 ^{*4}
Standard Type  Motor shaft shape One side milled/straight/with key	No	DC ^{*1}	DC ^{*1}	AC DC	AC DC	AC
	Yes	—	—	AC DC ^{*3}	AC DC	AC ^{*5}
TS Geared Type (Spur Gear Mechanism) Cable direction can be selected Downward, upward, right, left Low gear ratios, high-speed operations Gear Ratio 7.2, 10, 20, 30	No	—	—	AC DC	AC DC	AC
	Yes	—	—	AC DC	AC DC	AC
Right Angle Gearhead FC Geared Type (Face Gear Mechanism) Right-angled gearhead for positioning Gear Ratio 7.2, 10, 20, 30	No	—	—	AC DC	AC DC	—
	Yes	—	—	AC DC	AC DC	—
PS Geared Type (Planetary Gear Mechanism) A wide variety of gear ratios for selecting the desired step angle Gear Ratio 5, 7.2, 10, 25, 36, 50	No	—	NEW DC ^{*1}	AC DC	AC DC	AC
	Yes	—	—	AC DC	AC DC	AC
HPG Geared Type (Harmonic Drive®) High positioning accuracy Gear Ratio 5, 9, 15	No	—	—	AC DC	AC DC	AC
	Yes	—	—	AC DC	AC DC	AC
Harmonic Geared Type (Harmonic Drive®) High positioning accuracy Gear Ratio 50, 100	No	—	NEW DC ^{*1}	AC DC	AC DC	AC
	Yes	—	—	AC DC	AC DC	AC

*1 24 VDC only *2 HPG geared type is 40 mm *3 only for AZM46 *4 in case of geared type *5 only for AZM98 *6 Harmonic gear type is 30 mm

- Notes**
- Please use the above values as reference to see the differences between each type. These values vary depending on the motor frame size and gear ratio.
 - Harmonic planetary, harmonic drive and  are registered trademarks and trademarks of Harmonic Drive Systems Inc.

As a variation on stepper motors, we have prepared a geared motor in which the gears are combined. You can select the optimal type from among each geared motor, considering torque, accuracy (backlash) and price.

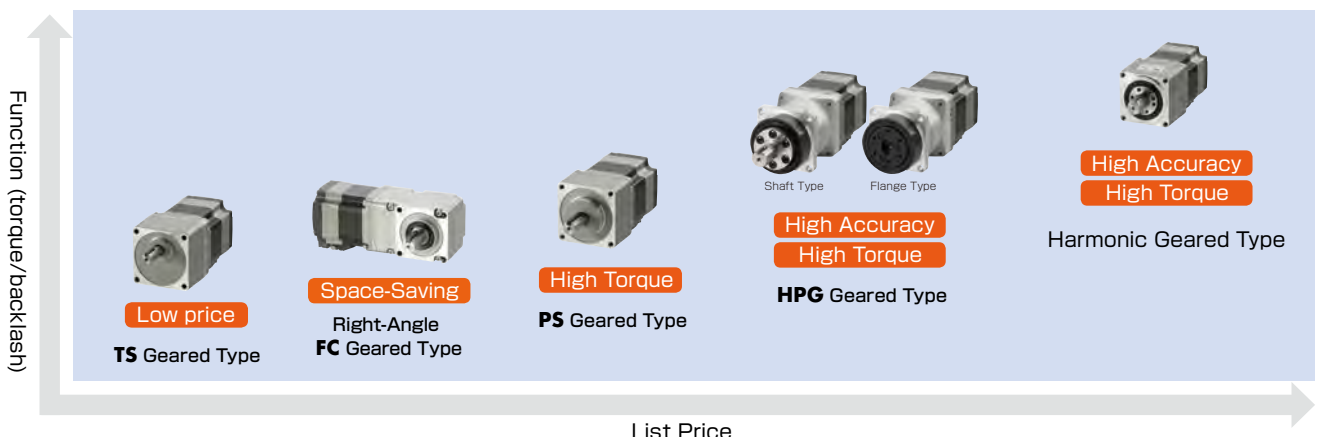

Permissible Torque, Instantaneous Maximum Torque [N·m]	Backlash [arcmin]	Basic Resolution [°/pulse]	Output Shaft Rotation Speed [r/min]
Excitation maximum static torque 4	—	0.36	6000
Permissible torque / Instantaneous maximum torque 25 45	10	0.012	833
Permissible torque 10.5	10	0.012	416
Permissible torque / Instantaneous maximum torque 37 60	7	0.0072	600
Permissible torque / Instantaneous maximum torque 24 33	3	0.024	900
Permissible torque / Instantaneous maximum torque 52 107	0	0.0036	70

Driver



Built-in Controller Type **FLEX**

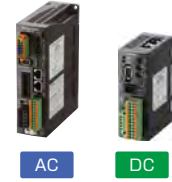

Pulse-Input Type with RS-485 Communication **FLEX** **NEW**

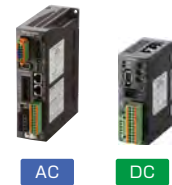

Pulse-Input Type



Network Compliant Multi-Axis Driver **NEW**



- FLEX** is the collective name for products that support I/O control, Modbus (RTU) control and FA network control via network converters.
- EtherCAT** is a registered trademark for which a license is provided by Beckhoff Automation GmbH in Germany.

Shaft Shape and Cable Direction can be Selected to the Needs of Application.

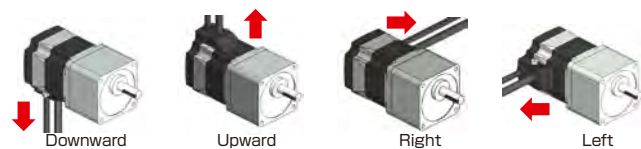

The cable direction can be selected out of four directions from the output shaft.

Standard Type

Frame Size	Shaft Shape	NEW	NEW
	One Side Milled	Straight	With key
20 mm	●	—	—
28 mm	●	—	—
42 mm	●	●	●*
60 mm	●	●	●
85 mm	●	●	●

*AZM48 only

TS Geared Type

Frame Size [mm]	Cable Direction			
	Downward	Upward	NEW	NEW
42	●	●	●	●
60	●	●	●	●
90	●	●	●	●

System Configuration

When Combining a Magnetic Brake Type Motor with a Built-in Controller Type Driver or Pulse-Input with RS-485 Communication Driver.

An example of a system configuration when using a built-in controller type driver by I/O or by RS-485. Motor, driver, cables should be ordered separately.

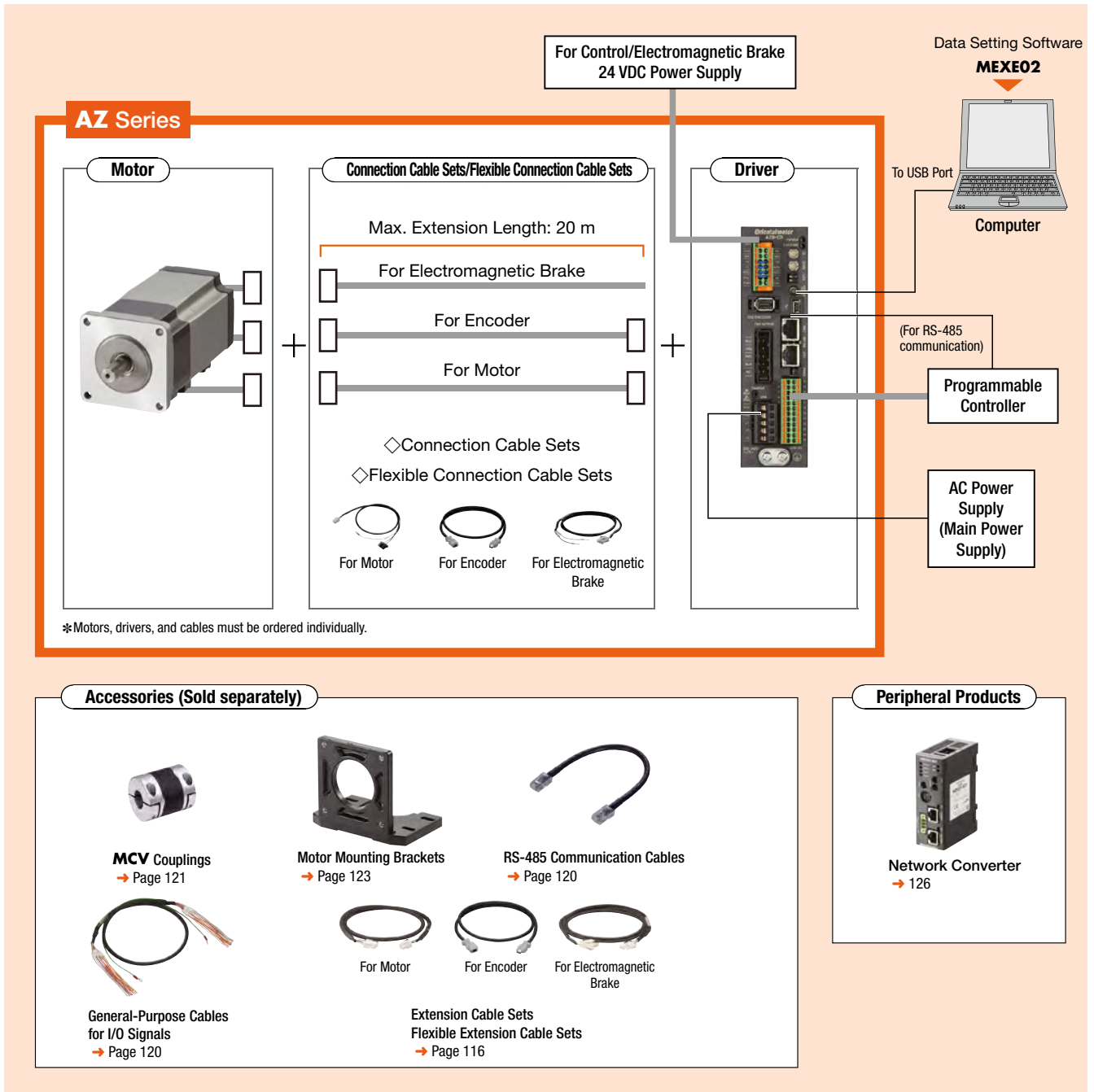

System configuration price example

AZ Series			Accessory		
Motor	Driver	Connection Cable Sets	Sold Separately		
AZM66MC	AZD-CD	CC030VZFB	Motor Mounting Bracket	Flexible Coupling	General-Purpose Cables for I/O Signals (1 m)
492.00 €	528.00 €	71.00 €	PAL2P-5	MCV251010	CC16D010B-1
			13.00 €	53.00 €	20.00 €

The system configuration shown above is an example. Other combinations are also available.

Note

The motor cable and electromagnetic brake cable from the motor cannot be connected directly to the driver. When connecting to a driver, use a connection cable.

● **Combination of Standard Type Motor with Electromagnetic Brake and Pulse Input Type Driver**

An example of a single-axis system configuration with the SCX11 controller is shown below.

Motors, drivers, and cables must be ordered individually.

*Not supplied.

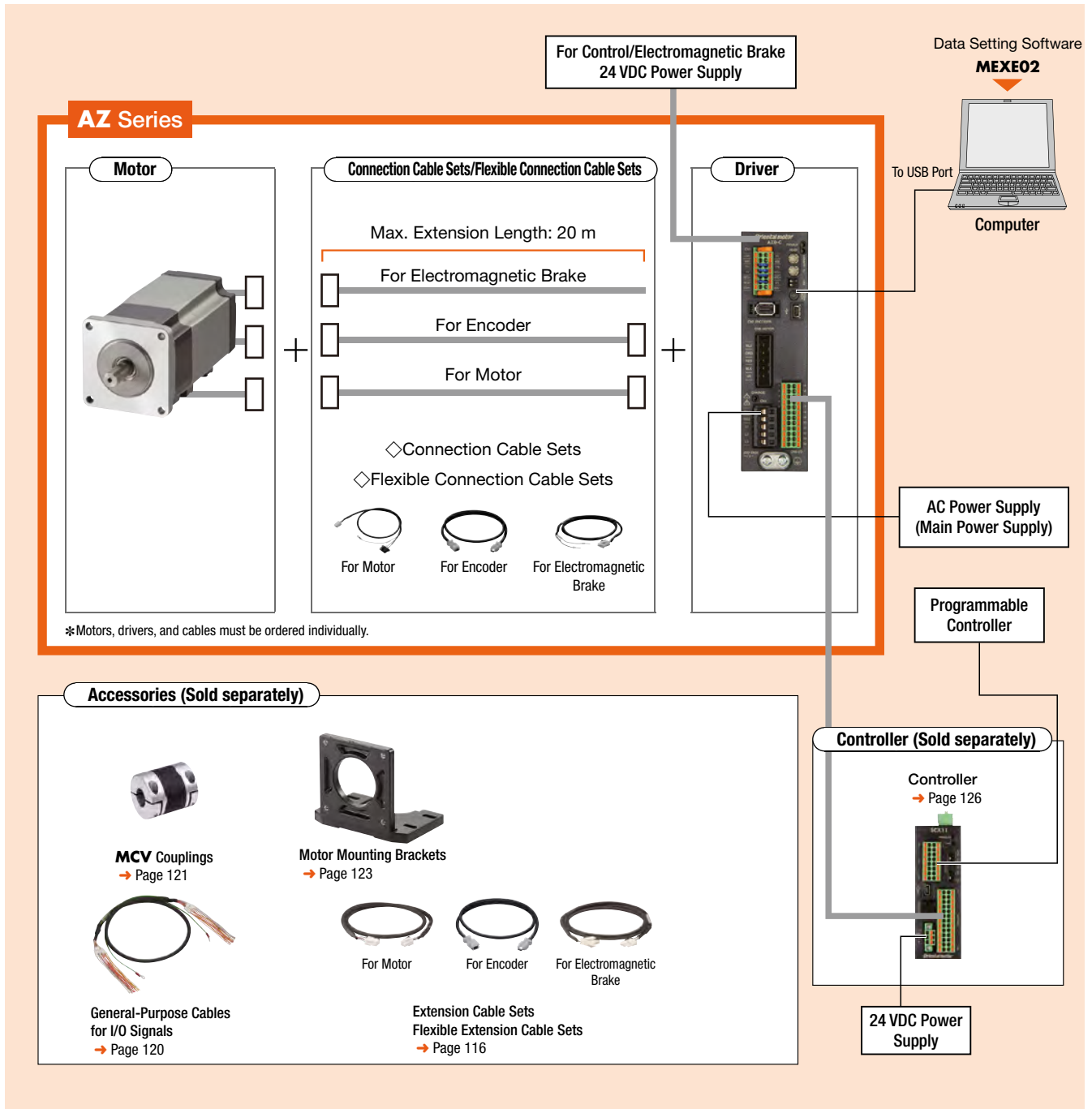

● **System configuration price example**

AZ Series			Accessory			
Motor	Driver	Connection Cable Sets	Sold Separately			
AZM66MC	AZD-C	CC030VZFB	Controller	Motor Mounting Bracket	Flexible Coupling	General-Purpose Cables for I/O Signals (1 m)
492.00 €	473.00 €	71.00 €	SCX11	PAL2P-5	MCV251010	CC16D010B-1
			237.00 €	13.00 €	53.00 €	20.00 €

● The system configuration shown above is an example. Other combinations are also available.

Note

● The motor cable and electromagnetic brake cable from the motor cannot be connected directly to the driver. When connecting to a driver, use a connection cable.

Features

System Configuration

Product Line

Specifications and Features

Dimensions

Connection and Operation

System Configuration

Product Line

Specifications and Features

Dimensions

Connection and Operation

Multiaxis Driver

Accessories

Product Number Code

Motor

◇ Standard Type

AZM 6 6 A 0 C

① ② ③ ④ ⑤ ⑥

◇ PS, HPG, Harmonic Geared Type

AZM 6 6 A C - HP 15 F

① ② ③ ④ ⑥ ⑦ ⑧ ⑨

◇ TS Geared Type

AZM 6 6 A C - TS 10 U

① ② ③ ④ ⑤ ⑥ ⑦ ⑧

◇ FC Geared Type

AZM 6 6 A C - FC 10 U A

① ② ③ ④ ⑤ ⑥ ⑦ ⑧ ⑨

Driver

AZD - C D

① ② ③

Connection Cable Sets/Flexible Connection Cable Sets

CC 050 V Z F B

① ② ③ ④ ⑤ ⑥

①	Motor Type	AZM: AZ Series Motor
②	Motor Frame Size	4: 42 mm (HPG Geared Type is 40 mm) 6: 60 mm 9: 85 mm (Geared Type is 90 mm)
③	Motor Case Length	
④	Configuration	A: Single Shaft M: With Electromagnetic Brake
⑤	Shaft Shape*	0: Straight Type 1: With Key
⑥	Motor Specification	C: AC Power Supply Input Specifications
⑦	Geared Type	PS: PS Geared Type HP: HPG Geared Type HS: Harmonic Geared Type
⑧	Gear Ratio	
⑧	Output Shaft Type	HPG Geared Type Blank: Shaft Output F: Flange Output

*For standard types without specified shaft shape one shaft side is milled.

①	Motor Type	AZM: AZ Series Motor
②	Motor Frame Size	4: 42 mm 6: 60 mm 9: 90 mm
③	Motor Case Length	
④	Configuration	A: Single Shaft M: With Electromagnetic Brake
⑤	Motor Specification	C: AC Power Supply Input Specifications
⑥	Geared Type	TS: TS Geared Type
⑦	Gear Ratio	
⑧	Cable Direction	U: Up L: Left R: Right

①	Motor Type	AZM: AZ Series Motor
②	Motor Frame Size	4: 42 mm 6: 60 mm
③	Motor Case Length	
④	Configuration	A: Single Shaft M: With Electromagnetic Brake
⑤	Motor Specification	C: AC Power Supply Input Specifications
⑥	Geared Type	FC: FC Geared Type
⑦	Gear Ratio	
⑧	Cable Direction	D: Down U: Up
⑨	Identification	A: Solid shaft

*With the output shaft pointing to the left the cable direction is defined by looking from the gearhead side.

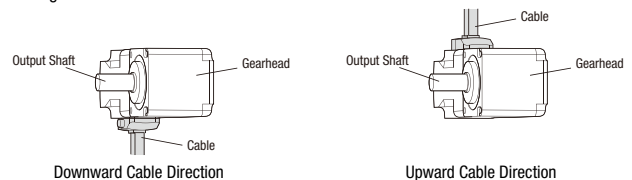

①	Driver Type	AZD: AZ Series Driver
②	Power Supply Input	C: Single-Phase 200~240 VAC
③	Type	D: Built-in Controller Type X: Pulse-Input Type with RS-485 Communication Blank: Pulse Input Type

①		CC: Cable
②	Length	005: 0.5 m 010: 1 m 015: 1.5 m 020: 2 m 025: 2.5 m 030: 3 m 040: 4 m 050: 5 m 070: 7 m 100: 10 m 150: 15 m 200: 20 m
③	Reference Number	
④	Applicable Models	Z: AZ Series
⑤	Cable Type	F: Connection Cable Sets R: Flexible Connection Cable Sets
⑥	Electromagnetic Brake	Blank: Without Electromagnetic Brake B: With Electromagnetic Brake

Product Line

For the single-phase 100-120 VAC models and three-phase 200-240 VAC models, please contact the nearest Oriental Motor sales office.

Motor

◇ Standard Type



Frame Size [mm]	Product Name	List Price
42	AZM46AC AZM46AOC	271.00 €
	AZM48AC AZM48AOC	281.00 €
	AZM48A1C	292.00 €
60	AZM66AC AZM66AOC	319.00 €
	AZM66A1C	319.00 €
	AZM69AC AZM69AOC	325.00 €
	AZM69A1C	325.00 €
	AZM98AC AZM98AOC	347.00 €
85	AZM98A1C	357.00 €
	AZM911AC AZM911AOC	367.00 €
	AZM911A1C	377.00 €

◇ Standard Type with Electromagnetic Brake



Frame Size [mm]	Product Name	List Price
42	AZM46MC AZM46MOC	405.00 €
60	AZM66MC AZM66MOC	492.00 €
	AZM66M1C	492.00 €
	AZM69MC AZM69MOC	498.00 €
85	AZM69M1C	506.00 €
	AZM98MC AZM98MOC	538.00 €
	AZM98M1C	547.00 €

◇ TS Geared Type



Frame Size [mm]	Product Name	Gear Ratio	List Price
42	AZM46AC-TS □◇ AZM46AC-TS □◇	3.6, 7.2 10, 20, 30	376.00 € 387.00 €
	60	AZM66AC-TS □◇ AZM66AC-TS □◇	3.6, 7.2 10, 20, 30
90		AZM98AC-TS □◇ AZM98AC-TS □◇	3.6, 7.2 10, 20, 30

◇ TS Geared Type with Electromagnetic Brake



Frame Size [mm]	Product Name	Gear Ratio	List Price
42	AZM46MC-TS □◇ AZM46MC-TS □◇	3.6, 7.2 10, 20, 30	510.00 € 521.00 €
	60	AZM66MC-TS □◇ AZM66MC-TS □◇	3.6, 7.2 10, 20, 30
90		AZM98MC-TS □◇ AZM98MC-TS □◇	3.6, 7.2 10, 20, 30

◇ FC Geared Type



Frame Size [mm]	Product Name	Gear Ratio	List Price
42	AZM46AC-FC □UA AZM46AC-FC □DA	7.2, 10, 20, 30	497.00 €
	60	AZM66AC-FC □UA AZM66AC-FC □DA	7.2, 10, 20, 30

◇ FC Geared Type with Electromagnetic Brake



Frame Size [mm]	Product Name	Gear Ratio	List Price
42	AZM46MC-FC □UA AZM46MC-FC □DA	7.2, 10, 20, 30	631.00 €
	60	AZM66MC-FC □UA AZM66MC-FC □DA	7.2, 10, 20, 30

◇ PS Geared Type



Frame Size [mm]	Product Name	Gear Ratio	List Price
42	AZM46AC-PS □ AZM46AC-PS □	5, 7.2, 10 25, 36, 50	455.00 € 495.00 €
	60	AZM66AC-PS □ AZM66AC-PS □	5, 7.2, 10 25, 36, 50
90		AZM98AC-PS □ AZM98AC-PS □	5, 7.2, 10 25, 36, 50

◇ PS Geared Type with Electromagnetic Brake



Frame Size [mm]	Product Name	Gear Ratio	List Price
42	AZM46MC-PS □ AZM46MC-PS □	5, 7.2, 10 25, 36, 50	589.00 € 630.00 €
	60	AZM66MC-PS □ AZM66MC-PS □	5, 7.2, 10 25, 36, 50
90		AZM98MC-PS □ AZM98MC-PS □	5, 7.2, 10 25, 36, 50

● A number indicating the gear ratio is entered where the box □ is located in the product name.

● Either **R** (right), **L** (left) or **U** (up) is entered for the cable withdrawing direction in ◇ in the product name.

Features

System Configuration

Product Line

Specifications and Features

Dimensions

Connection and Operation

System Configuration

Product Line

Specifications and Features

DC Input

Dimensions

Connection and Operation

Multiaxis Driver

Accessories



◇ **HPG Geared Type**

Frame Size [mm]	Product Name	List Price
40	AZM46AC-HP5	605.00 €
	AZM46AC-HP5F	594.00 €
	AZM46AC-HP9	605.00 €
	AZM46AC-HP9F	594.00 €
60	AZM66AC-HP5	817.00 €
	AZM66AC-HP5F	800.00 €
	AZM66AC-HP15	961.00 €
	AZM66AC-HP15F	943.00 €
90	AZM98AC-HP5	1,030.00 €
	AZM98AC-HP5F	1,007.00 €
	AZM98AC-HP15	1,139.00 €
	AZM98AC-HP15F	1,116.00 €



◇ **HPG Geared Type with Electromagnetic Brake**

Frame Size [mm]	Product Name	List Price
40	AZM46MC-HP5	746.00 €
	AZM46MC-HP5F	734.00 €
	AZM46MC-HP9	746.00 €
	AZM46MC-HP9F	734.00 €
60	AZM66MC-HP5	998.00 €
	AZM66MC-HP5F	980.00 €
	AZM66MC-HP15	1,141.00 €
	AZM66MC-HP15F	1,124.00 €
90	AZM98MC-HP5	1,230.00 €
	AZM98MC-HP5F	1,207.00 €
	AZM98MC-HP15	1,339.00 €
	AZM98MC-HP15F	1,316.00 €



◇ **Harmonic Geared Type**

Frame Size [mm]	Product Name	Gear Ratio	List Price
42	AZM46AC-HS □	50, 100	772.00 €
60	AZM66AC-HS □		1,040.00 €
90	AZM98AC-HS □		1,139.00 €



◇ **Harmonic Geared Type with Electromagnetic Brake**

Frame Size [mm]	Product Name	Gear Ratio	List Price
42	AZM46MC-HS50	50, 100	906.00 €
60	AZM66MC-HS50		1,213.00 €
90	AZM98MC-HS50		1,440.00 €

● **Driver**

◇ **Built-in Controller Type**

Power Supply Input	Product Name	List Price
Single-Phase 200-240 VAC	AZD-CD	528.00 €



◇ **Pulse-Input Type with RS-485 Communication**

Power Supply Input	Product Name	List Price
Single-Phase 200-240 VAC	AZD-CX	528.00 €



◇ **Pulse Input Type**

Power Supply Input	Product Name	List Price
Single-Phase 200-240 VAC	AZD-C	473.00 €



● Connection Cable Sets/Flexible Connection Cable Sets

Use the flexible connection cable in applications where the cable is bent and flexed repeatedly. To extend the connection cables extension cables and flexible extension cables are provided. Please see page 116.

The motor cable and electromagnetic brake cable from the motor cannot be connected directly to the driver. Use a connection cable to connect the driver.



For Motor For Encoder

◇ Without Electromagnetic Brake

Product Line	Length L [m]	Product Name	List Price
Connection Cable Sets	0.5	CC005VZF	34.00 €
	1	CC010VZF	34.00 €
	1.5	CC015VZF	38.00 €
	2	CC020VZF	44.00 €
	2.5	CC025VZF	49.00 €
	3	CC030VZF	55.00 €
	4	CC040VZF	82.00 €
	5	CC050VZF	92.00 €
	7	CC070VZF	114.00 €
	10	CC100VZF	149.00 €
	15	CC150VZF	206.00 €
	20	CC200VZF	261.00 €
Flexible Connection Cable Sets	0.5	CC005VZR	72.00 €
	1	CC010VZR	72.00 €
	1.5	CC015VZR	77.00 €
	2	CC020VZR	83.00 €
	2.5	CC025VZR	88.00 €
	3	CC030VZR	93.00 €
	4	CC040VZR	107.00 €
	5	CC050VZR	119.00 €
	7	CC070VZR	151.00 €
	10	CC100VZR	200.00 €
	15	CC150VZR	289.00 €
	20	CC200VZR	359.00 €



For Motor For Encoder For Electromagnetic Brake

◇ Type with an Electromagnetic Brake

Product Line	Length L [m]	Product Name	List Price
Connection Cable Sets	0.5	CC005VZFB	46.00 €
	1	CC010VZFB	46.00 €
	1.5	CC015VZFB	52.00 €
	2	CC020VZFB	59.00 €
	2.5	CC025VZFB	65.00 €
	3	CC030VZFB	71.00 €
	4	CC040VZFB	102.00 €
	5	CC050VZFB	113.00 €
	7	CC070VZFB	140.00 €
	10	CC100VZFB	180.00 €
	15	CC150VZFB	248.00 €
	20	CC200VZFB	314.00 €
Flexible Connection Cable Sets	0.5	CC005VZRB	95.00 €
	1	CC010VZRB	95.00 €
	1.5	CC015VZRB	105.00 €
	2	CC020VZRB	114.00 €
	2.5	CC025VZRB	119.00 €
	3	CC030VZRB	127.00 €
	4	CC040VZRB	143.00 €
	5	CC050VZRB	161.00 €
	7	CC070VZRB	203.00 €
	10	CC100VZRB	261.00 €
	15	CC150VZRB	365.00 €
	20	CC200VZRB	465.00 €

■ Included

● Motor

Type	Included	Parallel Key	Motor Installation Screw	Operating Manual
Standard	—	—	—	1 Copy
TS Geared	Frame Size 42 mm	—	—	
	Frame Size 60 mm	1 Piece	M4×60 P0.7 (4 Screws)	
	Frame Size 90 mm	1 Piece	M8×90 P1.25 (4 Screws)	
FC Geared	1 Piece	—	—	
PS Geared	1 Piece	—	—	
HPG Geared	Shaft Output	1 Piece	—	
	Flange Output	—	—	
Harmonic Geared	1 Piece	—	—	

● For the functions and operation of the product please refer to the operating manual (function edition). The function edition is not included in the product, please contact the nearest sales office or download it from the website.

● Driver

Type	Included	Connector	Operating Manual
Built-in Controller Type Pulse Input Type	—	<ul style="list-style-type: none"> • Connector for CN4 (1 Piece) • Connector for CN1 (1 Piece) • Connector for CN5 (1 Piece) • Connector Wiring Lever (1 Piece) 	1 Copy

● Connection Cable Sets / Flexible Connection Cable Sets

Type	Included	Operating Manual
Connection Cable Sets Flexible Connection Cable Sets	—	1 Copy

Output Power of Stepper Motors (Reference Values)

The output power (W) of AC servomotors is displayed as rated torque, i.e. the output power (W) when rotating at rated speed.

On the other hand, as stepper motors featuring with high positioning accuracy and high torque at low and medium speeds don't have a rated speed, the rated output power cannot be displayed. For reference it is shown below which torque of the **AZ** Series Standard Type is equivalent to which rated torque of the servomotor.

AZ Series (Standard Type)			Equivalent Rated Torque of Servomotor (Reference Value)
Frame Size [mm]	Product Name	Price	
42	AZM46	from 778.00 €	Equivalent to Rated Torque of 50-100 W
	AZM48	from 788.00 €	
60	AZM66	from 826.00 €	Equivalent to Rated Torque of 100-200 W
	AZM69	from 832.00 €	Equivalent to Rated Torque of 200-400 W
85	AZM98	from 854.00 €	Equivalent to Rated Torque of 400-750 W
	AZM911	from 874.00 €	

*Total price for motor, driver and 1 m connection cable.

● Frame Size 42 mm

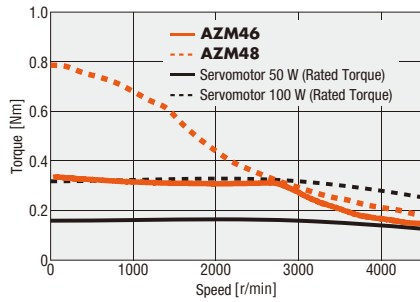

● Frame Size 60 mm

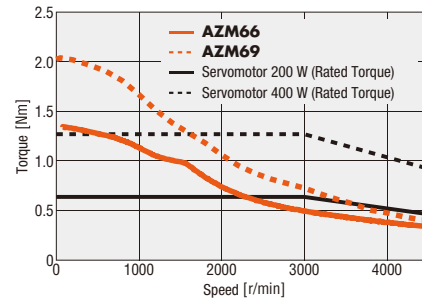

● Frame Size 85 mm

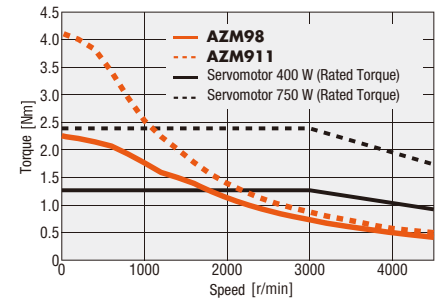

● Data for the speed-torque characteristics is based on Oriental Motor's internal measurement conditions. If the conditions are changed, the characteristics may also change as a result.

Standard Type Frame Size 42 mm, 60 mm, 85 mm

Specifications



Motor Product Name	Single Shaft	AZM46A□C	AZM48A□C	AZM66A□C	AZM69A□C	AZM98A□C	AZM911A□C	
	With Electromagnetic Brake	AZM46M□C	—	AZM66M□C	AZM69M□C	AZM98M□C	—	
Driver Product Name	Built-in Controller Type	AZD-CD (Single-Phase 200-240 VAC)						
	Pulse-Input Type with RS-485 Communication	AZD-CX (Single-Phase 200-240 VAC)						
	Pulse Input Type	AZD-C (Single-Phase 200-240 VAC)						
Maximum Holding Torque	Nm	0.3	0.77	1.2	2	2	4	
Holding Torque at Motor Standstill	Power ON	Nm	0.15	0.38	0.6	1	1	2
	With Electromagnetic Brake	Nm	0.15	—	0.6	1	1	—
Rotor Inertia	J: kg m ²	55×10^{-7} (71×10^{-7})*1	115×10^{-7}	370×10^{-7} (530×10^{-7})*1	740×10^{-7} (900×10^{-7})*1	1090×10^{-7} (1250×10^{-7})*1	2200×10^{-7}	
Resolution	Resolution Setting: 1000 P/R	0.36°/Pulse						
Power Supply Input	Voltage and Frequency	Single-Phase 200-240 VAC -15~+6% 50/60 Hz						
	Input Current	A	1.7	1.6	2.3	3.3	3.3	3.9
Control Power Supply		24 VDC ±5%*2 0.25 A (0.33 A)*1	24 VDC ±5% 0.25 A	24 VDC ±5%*2 0.25 A (0.5 A)*1				

● Either **0** (straight) or **1** (with key) indicating the shaft shape is entered where the box □ is located in the product name. (For **AZM46** straight only). For the one side milled shaft shape no number is specified.

*1 The brackets () indicate the specifications for the product with an electromagnetic brake.

*2 For the type with an electromagnetic brake, a 24 VDC±4% specification applies if the wiring distance between the motor and driver is extended to 20 m using a cable.

Speed - Torque Characteristics (Reference Value)

AZM46

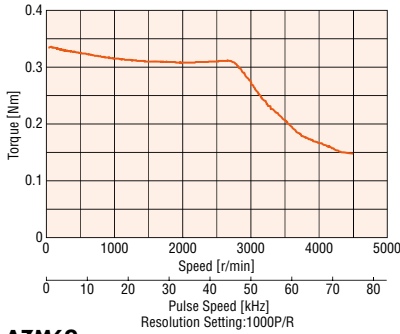

AZM48

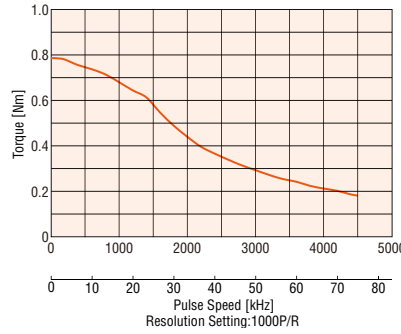

AZM66

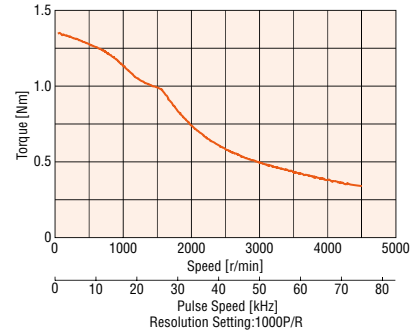

AZM69

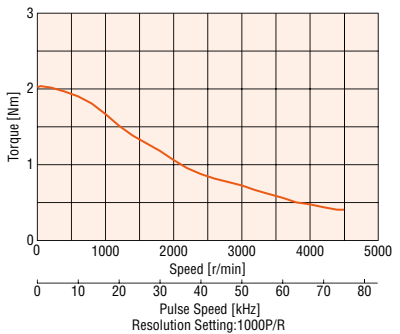

AZM98

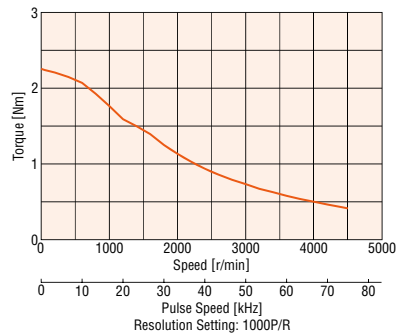

AZM911

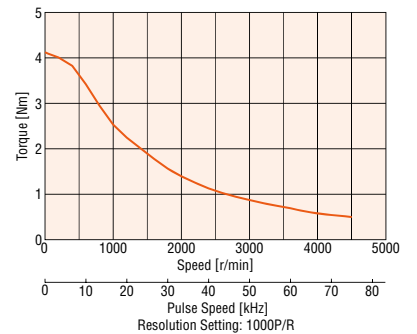

Notes

- The speed-torque characteristics are data based upon our measurement conditions. When these conditions change, these characteristics may change.
- Depending on the driving conditions, a considerable amount of heat may be generated by the motor. Be sure to keep the motor case temperature at 80°C or less in order to protect the ABZO sensor. (When conforming to the UL standards, it is required to keep the temperature of the motor case at 75°C or less, since the motor is recognized as thermal class A.)

Explanation of Terms in Specifications Table

Maximum Holding Torque	The maximum holding torque (holding force) the motor has when power (rated current) is being supplied but the motor shaft is at standstill. (With geared types, the value of holding torque considers the permissible strength of the gear.)	
Permissible Torque	This is the maximum torque continuously applied to the gear output shaft.	
Max. Instantaneous Torque	This is the maximum torque that can be applied to the gear output shaft during acceleration/deceleration, such as when an inertial load is started and stopped.	
Holding Torque at Motor Standstill	When Power is ON	This is the holding torque when the automatic current cutback function is activated.
	Electromagnetic Brake	This is the static friction torque that the electromagnetic brake can generate at rest. (Electromagnetic brake is power off activated type.)

TS Geared Type Frame Size 42 mm

Specifications



Motor Product Name	Single Shaft	AZM46AC-TS3.6 <input type="checkbox"/>	AZM46AC-TS7.2 <input type="checkbox"/>	AZM46AC-TS10 <input type="checkbox"/>	AZM46AC-TS20 <input type="checkbox"/>	AZM46AC-TS30 <input type="checkbox"/>
	With Electromagnetic Brake	AZM46MC-TS3.6 <input type="checkbox"/>	AZM46MC-TS7.2 <input type="checkbox"/>	AZM46MC-TS10 <input type="checkbox"/>	AZM46MC-TS20 <input type="checkbox"/>	AZM46MC-TS30 <input type="checkbox"/>
Driver Product Name	Built-in Controller Type	AZD-CD (Single-Phase 200-240 VAC)				
	Pulse-Input Type with RS-485 Communication	AZD-CX (Single-Phase 200-240 VAC)				
	Pulse Input Type	AZD-C (Single-Phase 200-240 VAC)				
Maximum Holding Torque	Nm	0.65	1.2	1.7	2	2.3
Rotor Inertia	J: kg m ²	55×10^{-7} (71×10^{-7})*1				
Gear Ratio		3.6	7.2	10	20	30
Resolution	Resolution Setting: 1000P/R	0.1°/Pulse	0.05°/Pulse	0.036°/Pulse	0.018°/Pulse	0.012°/Pulse
Permissible Torque	N·m	0.65	1.2	1.7	2	2.3
Maximum Instantaneous Torque	N·m	0.85	1.6	2	3	
Holding Torque at	Power ON	N·m	0.54	1	1.5	2.2
Motor Standstill	With Electromagnetic Brake	N·m	0.54	1	1.5	2.2
Speed Range	r/min	0~833	0~416	0~300	0~150	0~100
Backlash	arcmin	45 (0.75)	25 (0.42)		15 (0.25)	
Power Supply Input	Voltage and Frequency	Single-Phase 200-240 VAC -15~+6% 50/60 Hz				
	Input Current	A 1.7				
Control Power Supply		24 VDC ±5%*2 0.25 A (0.33 A)*1				

● Either **R** (right), **U** (up) or **L** (left) indicating the cable withdrawing direction is entered where the box is located within the product name. For the downward direction no letter is entered in the box .

*1 The brackets () indicate the specifications for the product with an electromagnetic brake.

*2 If a 20 m extension cable is used for the electromagnetic brake type, the 24 VDC±4% specification applies.

Speed - Torque Characteristics (Reference Value)

AZM46 Gear Ratio 3.6

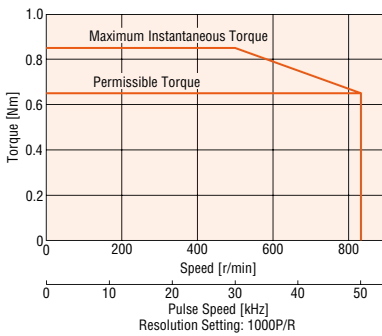

AZM46 Gear Ratio 7.2

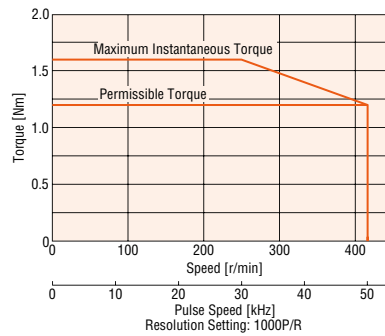

AZM46 Gear Ratio 10

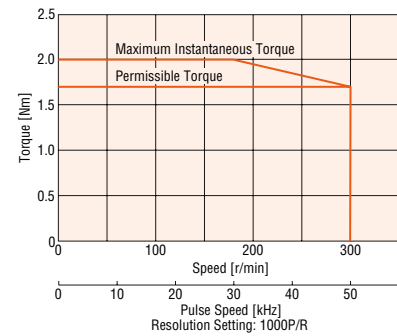

AZM46 Gear Ratio 20

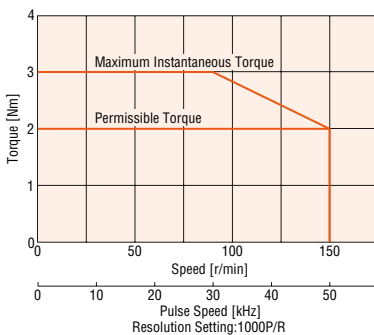

AZM46 Gear Ratio 30

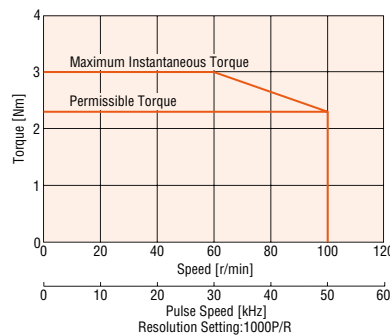

Notes

● The speed-torque characteristics are data based upon our measurement conditions. When these conditions change, these characteristics may change.

● Depending on the driving conditions, a considerable amount of heat may be generated by the motor. Be sure to keep the motor case temperature at 80 °C or less in order to protect the ABZO sensor. (When conforming to the UL standards, it is required to keep the temperature of the motor case at 75 °C or less, since the motor is recognized as thermal class A.)

TS Geared Type Frame Size 60 mm

Specifications



Motor Product Name	Single Shaft	AZM66AC-TS3.6	AZM66AC-TS7.2	AZM66AC-TS10	AZM66AC-TS20	AZM66AC-TS30
With Electromagnetic Brake		AZM66MC-TS3.6	AZM66MC-TS7.2	AZM66MC-TS10	AZM66MC-TS20	AZM66MC-TS30
Driver Product Name	Built-in Controller Type	AZD-CD (Single-Phase 200-240 VAC)				
Pulse-Input Type with RS-485 Communication		AZD-CX (Single-Phase 200-240 VAC)				
Pulse Input Type		AZD-C (Single-Phase 200-240 VAC)				
Maximum Holding Torque	Nm	1.8	3	4	5	6
Rotor Inertia	J: kg m ²	370×10 ⁻⁷ (530×10 ⁻⁷)*1				
Gear Ratio		3.6	7.2	10	20	30
Resolution	Resolution Setting: 1000P/R	0.1°/Pulse	0.05°/Pulse	0.036°/Pulse	0.018°/Pulse	0.012°/Pulse
Permissible Torque	Nm	1.8	3	4	5	6
Maximum Instantaneous Torque*	Nm	*	4.5	6	8	10
Holding Torque at Power ON	Nm	1.3	2.6	3.7	5	6
Motor Standstill With Electromagnetic Brake	Nm	1.3	2.6	3.7	5	6
Speed Range	r/min	0~833	0~416	0~300	0~150	0~100
Backlash	arcmin	35 (0.59)	15 (0.25)		10 (0.17)	
Power Supply Input	Voltage and Frequency	Single-Phase 200-240 VAC -15~+6% 50/60 Hz				
Input Current	A	2.3				
Control Power Supply		24 VDC ±5%*2 0.25 A (0.5 A)*1				

* For the geared motor output torque, refer to the speed – torque characteristics.

● Either **R** (right), **U** (up) or **L** (left) indicating the cable withdrawing direction is entered where the box □ is located within the product name. For the downward direction no letter is entered in the box □.

*1 The brackets () indicate the specifications for the product with an electromagnetic brake.

*2 If a 20 m extension cable is used for the electromagnetic brake type, the 24 VDC±4% specification applies.

Speed - Torque Characteristics (Reference Value)

AZM66 Gear Ratio 3.6

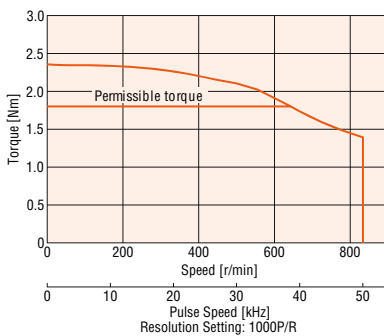

AZM66 Gear Ratio 7.2

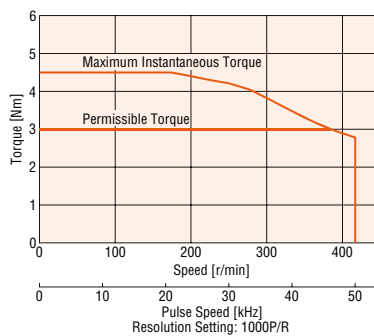

AZM66 Gear Ratio 10

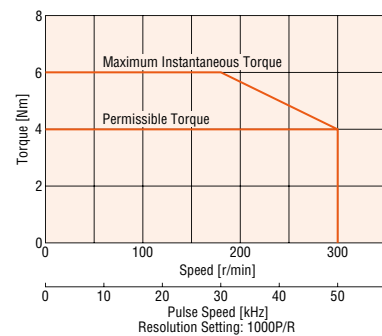

AZM66 Gear Ratio 20

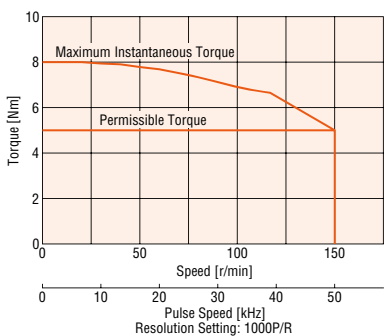

AZM66 Gear Ratio 30

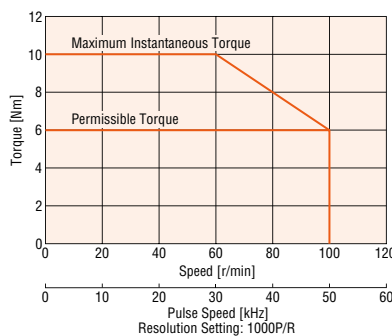

Notes

- The speed-torque characteristics are data based upon our measurement conditions. When these conditions change, these characteristics may change.
- Depending on the driving conditions, a considerable amount of heat may be generated by the motor. Be sure to keep the motor case temperature at 80 °C or less in order to protect the ABZO sensor. (When conforming to the UL standards, it is required to keep the temperature of the motor case at 75 °C or less, since the motor is recognized as thermal class A.)

TS Geared Type Frame Size 90 mm



Specifications

Motor Product Name	Single Shaft	AZM98AC-TS3.6 <input type="checkbox"/>	AZM98AC-TS7.2 <input type="checkbox"/>	AZM98AC-TS10 <input type="checkbox"/>	AZM98AC-TS20 <input type="checkbox"/>	AZM98AC-TS30 <input type="checkbox"/>
	With Electromagnetic Brake	AZM98MC-TS3.6 <input type="checkbox"/>	AZM98MC-TS7.2 <input type="checkbox"/>	AZM98MC-TS10 <input type="checkbox"/>	AZM98MC-TS20 <input type="checkbox"/>	AZM98MC-TS30 <input type="checkbox"/>
Driver Product Name	Built-in Controller Type	AZD-CD (Single-Phase 200-240 VAC)				
	Pulse-Input Type with RS-485 Communication	AZD-CX (Single-Phase 200-240 VAC)				
	Pulse Input Type	AZD-C (Single-Phase 200-240 VAC)				
Maximum Holding Torque	Nm	6	10	14	20	25
Rotor Inertia	J: kg m ²	1090×10 ⁻⁷ (1250×10 ⁻⁷)* ¹				
Gear Ratio		3.6	7.2	10	20	30
Resolution	Resolution Setting: 1000 P/R	0.1°/Pulse	0.05°/Pulse	0.036°/Pulse	0.018°/Pulse	0.012°/Pulse
Permissible Torque	Nm	6	10	14	20	25
Maximum Instantaneous Torque*	Nm	*	*	20	*	45
Holding Torque at Power ON	Nm	3.6	7.2	10	20	25
Motor Standstill With Electromagnetic Brake	Nm	3.6	7.2	10	20	25
Speed Range	r/min	0~833	0~416	0~300	0~150	0~100
Backlash	arcmin	25 (0.42)	15 (0.25)		10 (0.17)	
Power Supply Input	Voltage and Frequency	Single-Phase 200-240 VAC -15~+6% 50/60 Hz				
	Input Current	A 3.3				
Control Power Supply		24 VDC ±5%* ² 0.25 A (0.5 A)* ¹				

* For the geared motor output torque, refer to the speed – torque characteristics.

● Either **R** (right), **U** (up) or **L** (left) indicating the cable withdrawing direction is entered where the box is located within the product name. For the downward direction no letter is entered in the box .

*¹ The brackets () indicate the specifications for the product with an electromagnetic brake.

*² If a 20 m extension cable is used for the electromagnetic brake type, the 24 VDC ±4% specification applies.

Speed - Torque Characteristics (Reference Value)

AZM98 Gear Ratio 3.6

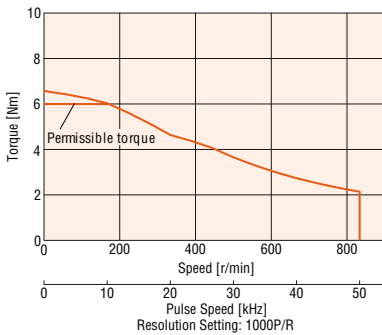

AZM98 Gear Ratio 7.2

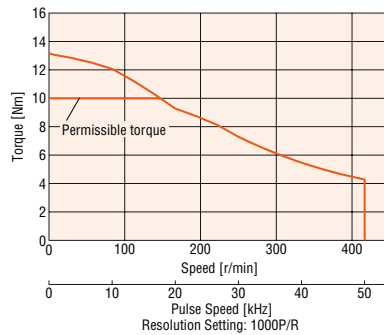

AZM98 Gear Ratio 10

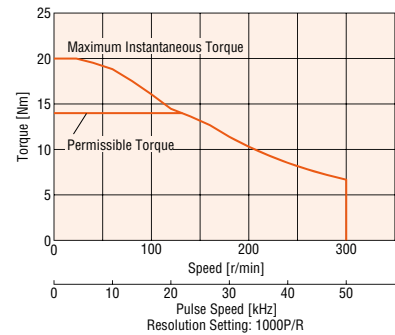

AZM98 Gear Ratio 20

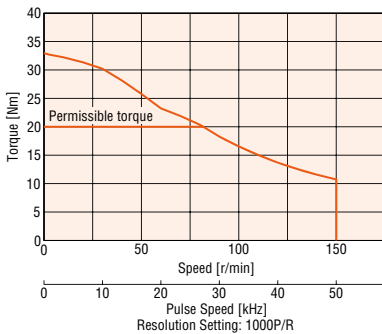

AZM98 Gear Ratio 30

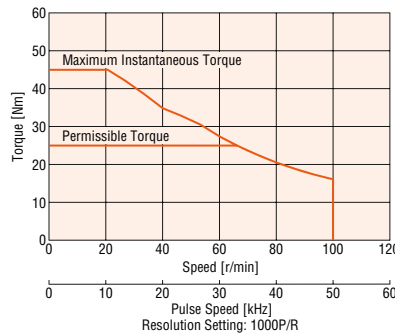

Notes

- The speed-torque characteristics are data based upon our measurement conditions. When these conditions change, these characteristics may change.
- Depending on the driving conditions, a considerable amount of heat may be generated by the motor. Be sure to keep the motor case temperature at 80 °C or less in order to protect the ABZO sensor. (When conforming to the UL standards, it is required to keep the temperature of the motor case at 75 °C or less, since the motor is recognized as thermal class A.)

FC Geared Type Frame Size 42 mm

Specifications



Motor Product Name	Single Shaft	AZM46AC-FC7.2□A	AZM46AC-FC10□A	AZM46AC-FC20□A	AZM46AC-FC30□A	
	With Electromagnetic Brake	AZM46MC-FC7.2□A	AZM46MC-FC10□A	AZM46MC-FC20□A	AZM46MC-FC30□A	
Driver Product Name	Built-in Controller Type	AZD-CD (Single-Phase 200-240 VAC)				
	Pulse Input Type with RS-485 Communication	AZD-CX (Single-Phase 200-240 VAC)				
	Pulse Input Type	AZD-C (Single-Phase 200-240 VAC)				
Maximum Holding Torque	Nm	0.7	1	2	3	
Rotor Inertia	J: kg m ²	55×10^{-7} (71×10^{-7})*1				
Gear Ratio		7.2	10	20	30	
Resolution	Resolution Setting: 1000P/R	0.05°/Pulse	0.036°/Pulse	0.018°/Pulse	0.012°/Pulse	
Permissible Torque	Nm	0.7	1	2	3	
Holding Torque at	Power ON	Nm	0.7	1	2	3
Motor Standstill	With Electromagnetic Brake	Nm	0.7	1	2	3
Speed Range	r/min	0~416	0~300	0~150	0~100	
Backlash	arcmin	25 (0.42°)		15 (0.25°)		
Power Supply Input	Voltage and Frequency	Single-Phase 200-240 VAC -15~+6% 50/60 Hz				
	Input Current	A 1.7				
Control Power Supply		24 VDC ±5%*2 0.25 A (0.5 A)*1				

● Either **U** (up) or **D** (down) indicating the cable withdrawing direction is entered where the box □ is located within the product name.

*1 The brackets () indicate the specifications for the product with an electromagnetic brake.

*2 If a 20 m extension cable is used for the electromagnetic brake type, the 24 VDC ±4% specification applies.

Speed - Torque Characteristics (Reference Value)

AZM46 Gear Ratio 7.2

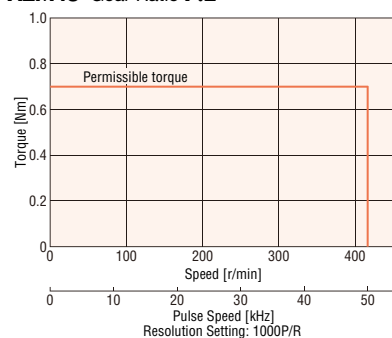

AZM46 Gear Ratio 10

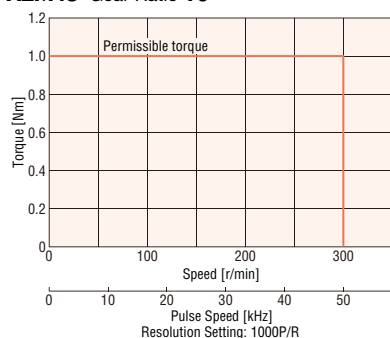

AZM46 Gear Ratio 20

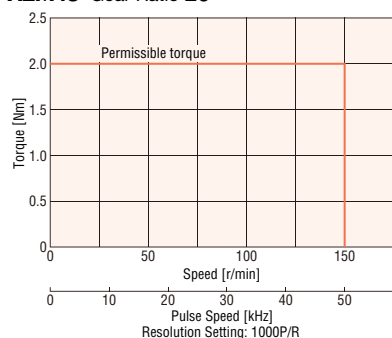

AZM46 Gear Ratio 30

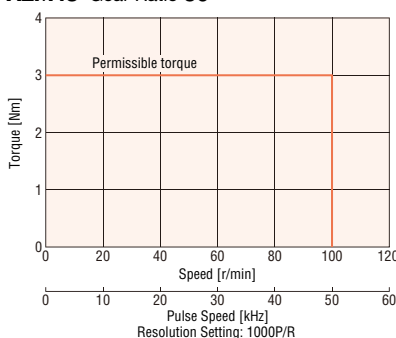

Notes

● The speed-torque characteristics are data based upon our measurement conditions. When these conditions change, these characteristics may change.

● Depending on the driving conditions, a considerable amount of heat may be generated by the motor. Be sure to keep the motor case temperature at 80 °C or less in order to protect the ABZO sensor. (When conforming to the UL standards, it is required to keep the temperature of the motor case at 75 °C or less, since the motor is recognized as thermal class A.)

Features

System Configuration

Product Line

Specifications and Features

AC Input

Dimensions

Connection and Operation

System Configuration

Product Line

Specifications and Features

DC Input

Dimensions

Connection and Operation

Multiaxis Driver

Accessories

FC Geared Type Frame Size 60 mm



Specifications

Motor Product Name	Single Shaft	AZM66AC-FC7.2□A	AZM66AC-FC10□A	AZM66AC-FC20□A	AZM66AC-FC30□A
With Electromagnetic Brake		AZM66MC-FC7.2□A	AZM66MC-FC10□A	AZM66MC-FC20□A	AZM66MC-FC30□A
Driver Product Name	Built-in Controller Type	AZD-CD (Single-Phase 200-240 VAC)			
Pulse-Input Type with RS-485 Communication		AZD-CX (Single-Phase 200-240 VAC)			
Pulse Input Type		AZD-C (Single-Phase 200-240 VAC)			
Maximum Holding Torque	Nm	2.5	3.5	7	10
Rotor Inertia	J: kg m ²	370×10 ⁻⁷ (530×10 ⁻⁷)*1			
Gear Ratio		7.2	10	20	30
Resolution	Resolution Setting: 1000P/R	0.05°/Pulse	0.036°/Pulse	0.018°/Pulse	0.012°/Pulse
Permissible Torque	Nm	2.5	3.5	7	10
Holding Torque at Power ON	Nm	2.5	3.5	7	10
Motor Standstill With Electromagnetic Brake	Nm	2.5	3.5	7	10
Speed Range	r/min	0~416	0~300	0~150	0~100
Backlash	arcmin	15 (0.25°)		10 (0.17°)	
Power Supply Input	Voltage and Frequency	Single-Phase 200-240 VAC -15~+6% 50/60 Hz			
Input Current	A	2.3			
Control Power Supply		24 VDC ±5%*2 0.25 A (0.5 A)*1			

● Either **U** (up) or **D** (down) indicating the cable withdrawing direction is entered where the box □ is located within the product name.

*1 The brackets () indicate the specifications for the product with an electromagnetic brake.

*2 If a 20 m extension cable is used for the electromagnetic brake type, the 24 VDC ±4% specification applies.

Speed - Torque Characteristics (Reference Value)

AZM66 Gear Ratio 7.2

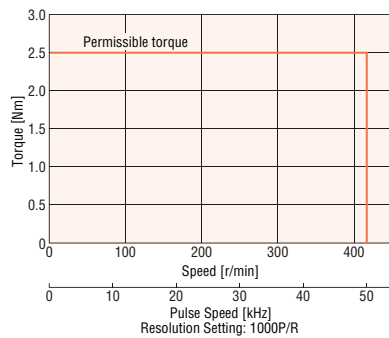

AZM66 Gear Ratio 10

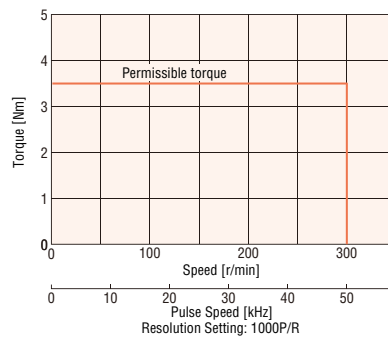

AZM66 Gear Ratio 20

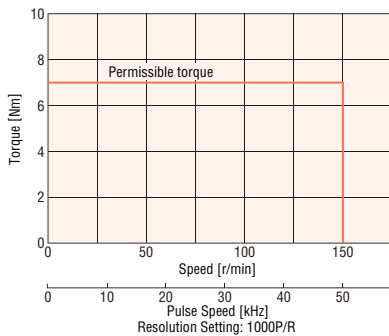

AZM66 Gear Ratio 30

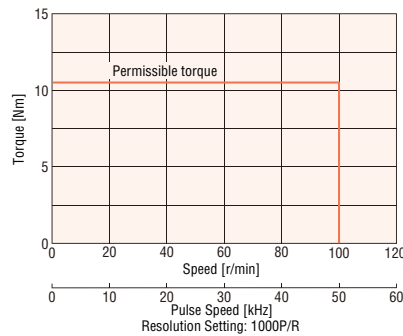

Notes

● The speed-torque characteristics are data based upon our measurement conditions. When these conditions change, these characteristics may change.

● Depending on the driving conditions, a considerable amount of heat may be generated by the motor. Be sure to keep the motor case temperature at 80 °C or less in order to protect the ABZO sensor. (When conforming to the UL standards, it is required to keep the temperature of the motor case at 75 °C or less, since the motor is recognized as thermal class A.)

PS Geared Type Frame Size 42 mm

Specifications



Motor Product Name	Single Shaft	AZM46AC-PS5	AZM46AC-PS7.2	AZM46AC-PS10	AZM46AC-PS25	AZM46AC-PS36	AZM46AC-PS50
With Electromagnetic Brake		AZM46MC-PS5	AZM46MC-PS7.2	AZM46MC-PS10	AZM46MC-PS25	AZM46MC-PS36	AZM46MC-PS50
Driver Product Name	Built-in Controller Type	AZD-CD (Single-Phase 200-240 VAC)					
Pulse-Input Type with RS-485 Communication		AZD-CX (Single-Phase 200-240 VAC)					
Pulse Input Type		AZD-C (Single-Phase 200-240 VAC)					
Maximum Holding Torque	Nm	1	1.5	2.5	3		
Rotor Inertia	J: kg m ²	55×10 ⁻⁷ (71×10 ⁻⁷)*1					
Gear Ratio		5	7.2	10	25	36	50
Resolution	Resolution Setting: 1000P/R	0.072°/Pulse	0.05°/Pulse	0.036°/Pulse	0.0144°/Pulse	0.01°/Pulse	0.0072°/Pulse
Permissible Torque	Nm	1	1.5	2.5	3		
Maximum Instantaneous Torque	Nm	1.5	2		6		
Holding Torque at Power ON	Nm	0.75	1	1.5	2.5	3	
Motor Standstill With Electromagnetic Brake	Nm	0.75	1	1.5	2.5	3	
Speed Range	r/min	0~600	0~416	0~300	0~120	0~83	0~60
Backlash	arcmin	15 (0.25°)					
Power Supply Input	Voltage and Frequency	Single-Phase 200-240 VAC -15~+6% 50/60 Hz					
	Input Current	1.7					
Control Power Supply		24 VDC ±5%*2 0.25 A (0.33 A)*1					

*1 The brackets () indicate the specifications for the product with an electromagnetic brake.

*2 If a 20 m extension cable is used for the electromagnetic brake type, the 24 VDC ±4% specification applies.

Speed - Torque Characteristics (Reference Value)

AZ46 Gear Ratio 5

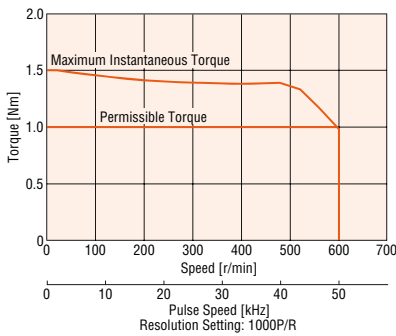

AZ46 Gear Ratio 7.2

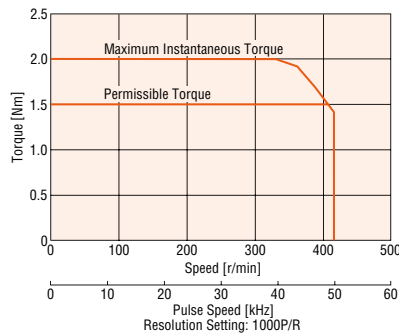

AZ46 Gear Ratio 10

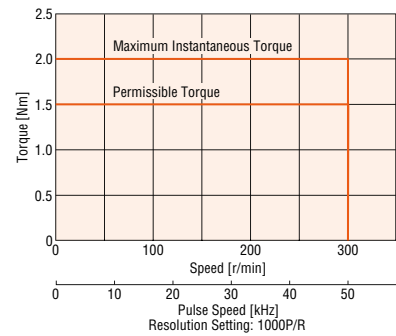

AZ46 Gear Ratio 25

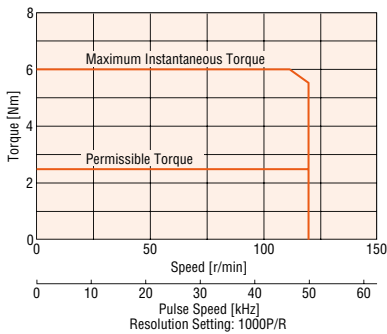

AZ46 Gear Ratio 36

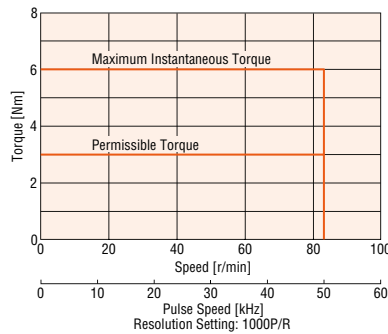

AZ46 Gear Ratio 50

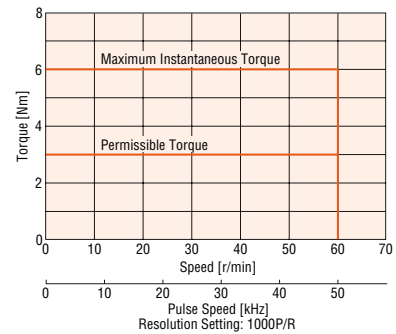

Notes

- The speed-torque characteristics are data based upon our measurement conditions. When these conditions change, these characteristics may change.
- Depending on the driving conditions, a considerable amount of heat may be generated by the motor. Be sure to keep the motor case temperature at 80 °C or less in order to protect the ABZO sensor. (When conforming to the UL standards, it is required to keep the temperature of the motor case at 75 °C or less, since the motor is recognized as thermal class A.)

PS Geared Type Frame Size 60 mm



Specifications

Motor Product Name	Single Shaft	AZM66AC-PS5	AZM66AC-PS7.2	AZM66AC-PS10	AZM66AC-PS25	AZM66AC-PS36	AZM66AC-PS50
With Electromagnetic Brake		AZM66MC-PS5	AZM66MC-PS7.2	AZM66MC-PS10	AZM66MC-PS25	AZM66MC-PS36	AZM66MC-PS50
Driver Product Name	Built-in Controller Type	AZD-CD (Single-Phase 200-240 VAC)					
Pulse-Input Type with RS-485 Communication		AZD-CX (Single-Phase 200-240 VAC)					
Pulse Input Type		AZD-C (Single-Phase 200-240 VAC)					
Maximum Holding Torque	Nm	3.5	4	5	8		
Rotor Inertia	J: kg m ²	370×10 ⁻⁷ (530×10 ⁻⁷)*1					
Gear Ratio		5	7.2	10	25	36	50
Resolution	Resolution Setting: 1000P/R	0.072°/Pulse	0.05°/Pulse	0.036°/Pulse	0.0144°/Pulse	0.01°/Pulse	0.0072°/Pulse
Permissible Torque	Nm	3.5	4	5	8		
Maximum Instantaneous Torque*	Nm	*	*	11	16	20	
Holding Torque at Power ON	Nm	3	4	5	8		
Motor Standstill With Electromagnetic Brake	Nm	3	4	5	8		
Speed Range	r/min	0~600	0~416	0~300	0~120	0~83	0~60
Backlash	arcmin	7 (0.12°)			9 (0.15°)		
Power Supply Input	Voltage and Frequency	Single-Phase 200-240 VAC -15~+6% 50/60 Hz					
Input Current	A	2.3					
Control Power Supply		24 VDC ±5%*2 0.25 A (0.5 A)*1					

* For the geared motor output torque, refer to the speed – torque characteristics.

*1 The brackets () indicate the specifications for the product with an electromagnetic brake.

*2 If a 20 m extension cable is used for the electromagnetic brake type, the 24 VDC ±4% specification applies.

Speed - Torque Characteristics (Reference Value)

AZ66 Gear Ratio 5

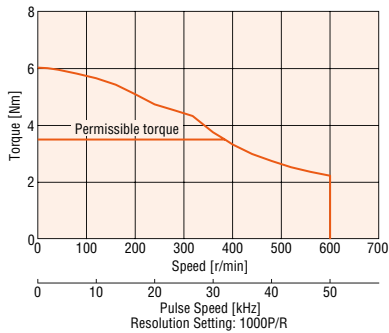

AZ66 Gear Ratio 7.2

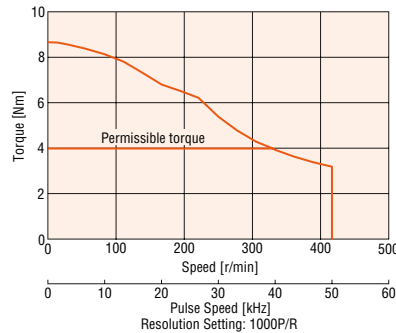

AZ66 Gear Ratio 10

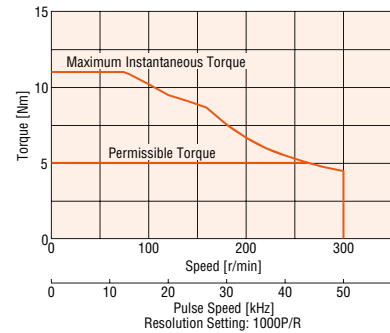

AZ66 Gear Ratio 25

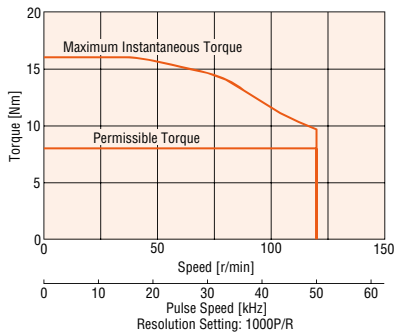

AZ66 Gear Ratio 36

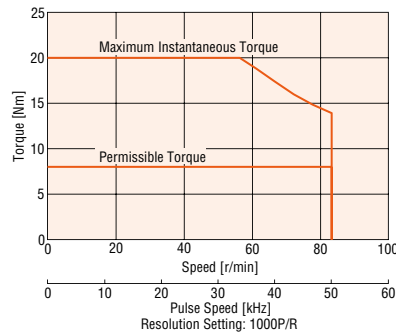

AZ66 Gear Ratio 50

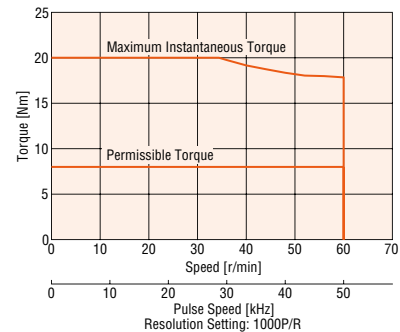

Notes

- The speed-torque characteristics are data based upon our measurement conditions. When these conditions change, these characteristics may change.
- Depending on the driving conditions, a considerable amount of heat may be generated by the motor. Be sure to keep the motor case temperature at 80 °C or less in order to protect the ABZO sensor. (When conforming to the UL standards, it is required to keep the temperature of the motor case at 75 °C or less, since the motor is recognized as thermal class A.)

PS Geared Type Frame Size 90 mm

Specifications



Motor Product Name	Single Shaft	AZM98AC-PS5	AZM98AC-PS7.2	AZM98AC-PS10	AZM98AC-PS25	AZM98AC-PS36	AZM98AC-PS50	
With Electromagnetic Brake		AZM98MC-PS5	AZM98MC-PS7.2	AZM98MC-PS10	AZM98MC-PS25	AZM98MC-PS36	AZM98MC-PS50	
Driver Product Name	Built-in Controller Type	AZD-CD (Single-Phase 200-240 VAC)						
Pulse-Input Type with RS-485 Communication		AZD-CX (Single-Phase 200-240 VAC)						
Pulse Input Type		AZD-C (Single-Phase 200-240 VAC)						
Maximum Holding Torque	Nm	10	14	20	37			
Rotor Inertia	J: kg m ²	1090×10 ⁻⁷ (1250×10 ⁻⁷)*1						
Gear Ratio		5	7.2	10	25	36	50	
Resolution	Resolution Setting: 1000 P/R	0.072°/Pulse	0.05°/Pulse	0.036°/Pulse	0.0144°/Pulse	0.01°/Pulse	0.0072°/Pulse	
Permissible Torque*	Nm	*	*	20	37			
Maximum Instantaneous Torque*	Nm	*	*	*	60			
Holding Torque at Motor Standstill	Power ON	Nm	5	7.2	10	25	36	37
With Electromagnetic Brake	Nm	5	7.2	10	25	36	37	
Speed Range	r/min	0~600	0~416	0~300	0~120	0~83	0~60	
Backlash	arcmin	7 (0.12)				9 (0.15)		
Power Supply Input	Voltage and Frequency	Single-Phase 200-240 VAC -15~+6% 50/60 Hz						
Input Current	A	3.3						
Control Power Supply		24 VDC ±5%*2 0.25 A (0.5 A)*1						

* For the geared motor output torque, refer to the speed – torque characteristics.

*1 The brackets () indicate the specifications for the product with an electromagnetic brake.

*2 If a 20 m extension cable is used for the electromagnetic brake type, the 24 VDC ±4% specification applies.

Speed - Torque Characteristics (Reference Value)

AZ98 Gear Ratio 5

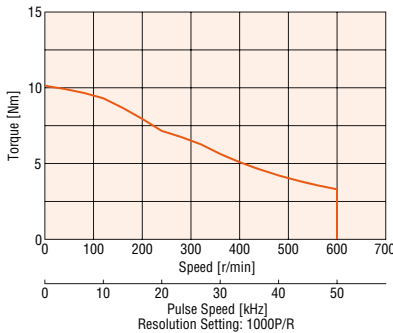

AZ98 Gear Ratio 7.2

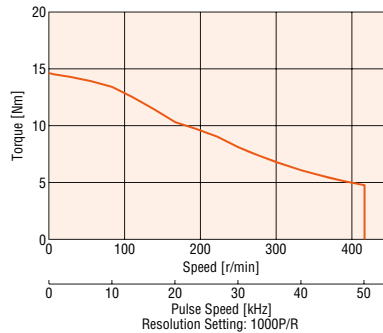

AZ98 Gear Ratio 10

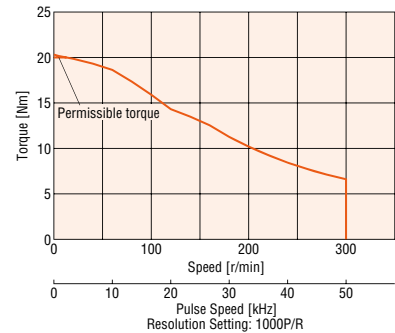

AZ98 Gear Ratio 25

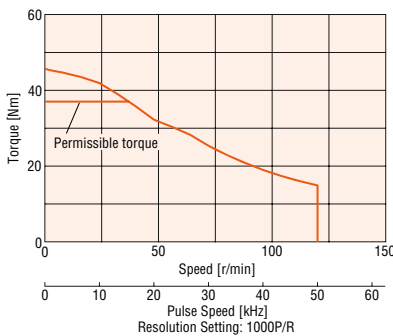

AZ98 Gear Ratio 36

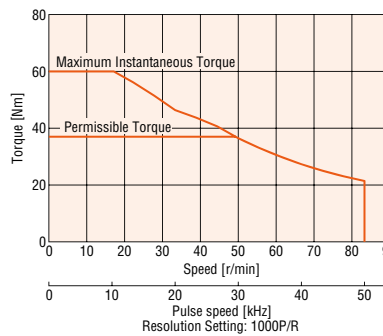

AZ98 Gear Ratio 50

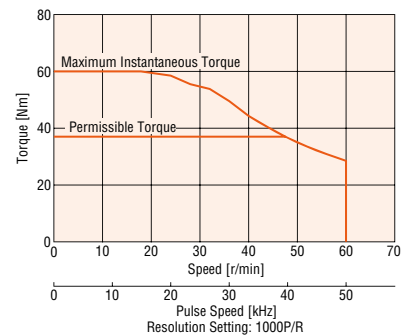

Notes

- The speed-torque characteristics are data based upon our measurement conditions. When these conditions change, these characteristics may change.
- Depending on the driving conditions, a considerable amount of heat may be generated by the motor. Be sure to keep the motor case temperature at 80 °C or less in order to protect the ABZO sensor. (When conforming to the UL standards, it is required to keep the temperature of the motor case at 75 °C or less, since the motor is recognized as thermal class A.)

HPG Geared Type Frame Size 40 mm, 60 mm, 90 mm



Specifications

Motor Product Name	Single Shaft	AZM46AC-HP5 □	AZM46AC-HP9 □	AZM66AC-HP5 □	AZM66AC-HP15 □	AZM98AC-HP5 □	AZM98AC-HP15 □
	With Electromagnetic Brake	AZM46MC-HP5 □	AZM46MC-HP9 □	AZM66MC-HP5 □	AZM66MC-HP15 □	AZM98MC-HP5 □	AZM98MC-HP15 □
Driver Product Name	Built-in Controller Type	AZD-CD (Single-Phase 200-240 VAC)					
	Pulse-Input Type with RS-485 Communication	AZD-CX (Single-Phase 200-240 VAC)					
	Pulse Input Type	AZD-C (Single-Phase 200-240 VAC)					
Maximum Holding Torque	Nm	1.5	2.5	5.9	9	10	24
Rotor Inertia	J: kg m ²	55×10 ⁻⁷ (71×10 ⁻⁷)*1		370×10 ⁻⁷ (530×10 ⁻⁷)*1		1090×10 ⁻⁷ (1250×10 ⁻⁷)*1	
Inertia*2	J: kg m ²	5.8×10 ⁻⁷ (4.2×10 ⁻⁷)	3.4×10 ⁻⁷ (2.9×10 ⁻⁷)	92×10 ⁻⁷ (86×10 ⁻⁷)	78×10 ⁻⁷ (77×10 ⁻⁷)	629×10 ⁻⁷ (589×10 ⁻⁷)	488×10 ⁻⁷ (488×10 ⁻⁷)
Gear Ratio		5	9	5	15	5	15
Resolution	Resolution Setting: 1000P/R	0.072°/Pulse	0.04°/Pulse	0.072°/Pulse	0.024°/Pulse	0.072°/Pulse	0.024°/Pulse
Permissible Torque*	Nm	*	2.5	5.9	9	*	24
Maximum Instantaneous Torque*	Nm	*	*	*	*	*	*
Holding Torque at Power ON	Nm	0.75	1.35	3	9	5	15
Motor Standstill With Electromagnetic Brake	Nm	0.75	1.35	3	9	5	15
Speed Range	r/min	0~900	0~500	0~900	0~300	0~900	0~300
Backlash	arcmin	3 (0.05°)					
Power Supply Input	Voltage and Frequency	Single-Phase 200-240 VAC -15~+6% 50/60 Hz					
	Input Current	1.7		2.3		3.3	
Control Power Supply		24 VDC ±5%*4 0.25 A (0.33 A)*1		24 VDC ±5%*4 0.25 A (0.5 A)*1			
Output Flange Surface Runout*3	mm	0.02				0.04	
Output Flange Inner Runout*3	mm	0.03		0.04			

- * For the geared motor output torque, refer to the speed – torque characteristics.
- For the flange output type, **F** is specified where the box □ is located in the product name.
- *1 The brackets () indicate the specifications for the product with an electromagnetic brake.
- *2 The internal inertia of the gear is the value converted to the motor shaft. () contain values for the flange output type.
- *3 Specifications for the flange output type.
- *4 If a 20 m extension cable is used for the electromagnetic brake type, the 24 VDC ±4% specification applies.

Speed - Torque Characteristics (Reference Value)

AZ46 Gear Ratio 5

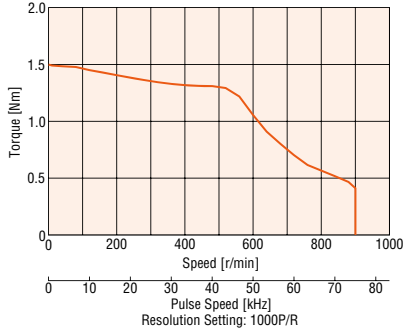

AZ66 Gear Ratio 5

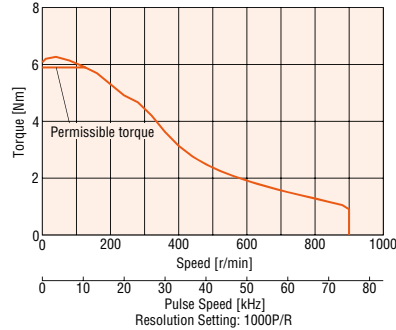

AZ98 Gear Ratio 5

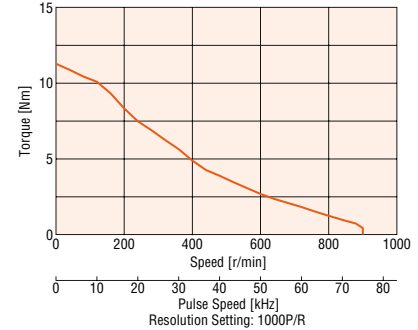

AZ46 Gear Ratio 9

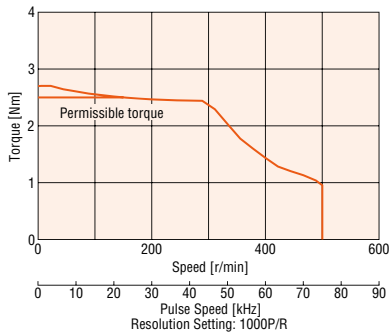

AZ66 Gear Ratio 15

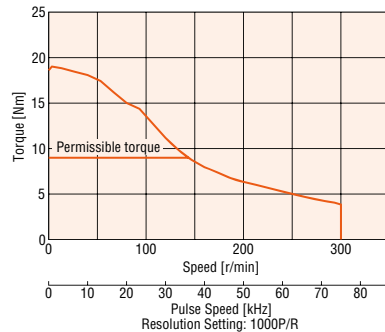

AZ98 Gear Ratio 15

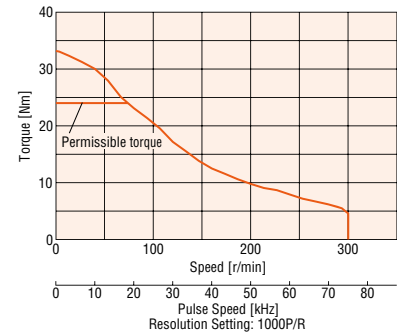

Notes

- The speed-torque characteristics are data based upon our measurement conditions. When these conditions change, these characteristics may change.
- Depending on the driving conditions, a considerable amount of heat may be generated by the motor. Be sure to keep the motor case temperature at 80 °C or less in order to protect the ABZO sensor. (When conforming to the UL standards, it is required to keep the temperature of the motor case at 75 °C or less, since the motor is recognized as thermal class A.)

Harmonic Geared Type Frame Size 42 mm, 60 mm, 90 mm

Specifications



Motor Product Name	Single Shaft	AZM46AC-HS50	AZM46AC-HS100	AZM66AC-HS50	AZM66AC-HS100	AZM98AC-HS50	AZM98AC-HS100	
	With Electromagnetic Brake	AZM46MC-HS50	AZM46MC-HS100	AZM66MC-HS50	AZM66MC-HS100	AZM98MC-HS50	AZM98MC-HS100	
Driver Product Name	Built-in Controller Type	AZD-CD (Single-Phase 200-240 VAC)						
	Pulse Input Type with RS-485 Communication	AZD-CX (Single-Phase 200-240 VAC)						
	Pulse Input Type	AZD-C (Single-Phase 200-240 VAC)						
Maximum Holding Torque	Nm	3.5	5	7	10	33	52	
Rotor Inertia	J: kg m ²	72×10 ⁻⁷ (88×10 ⁻⁷)*1		405×10 ⁻⁷ (565×10 ⁻⁷)*1		1290×10 ⁻⁷ (1450×10 ⁻⁷)*1		
Gear Ratio		50	100	50	100	50	100	
Resolution	Resolution Setting: 1000P/R	0.0072°/Pulse	0.0036°/Pulse	0.0072°/Pulse	0.0036°/Pulse	0.0072°/Pulse	0.0036°/Pulse	
Permissible Torque	Nm	3.5	5	7	10	33	52	
Maximum Instantaneous Torque*	Nm	8.3	11	23	36	*	107	
Holding Torque at Motor Standstill	Power ON	Nm	3.5	5	7	10	33	52
	With Electromagnetic Brake	Nm	3.5	5	7	10	33	52
Speed Range	r/min	0~70	0~35	0~70	0~35	0~70	0~35	
Lost Motion (Load Torque)		arcmin	1.5 max.	1.5 max.	0.7 max.	0.7 max.	0.7 max.	
			(±0.16 N-m)	(±0.20 N-m)	(±0.28 N-m)	(±0.39 N-m)	(±1.2 N-m)	
Power Supply Input	Voltage and Frequency	Single-Phase 200-240 VAC -15~+6% 50/60 Hz						
	Input Current	A	1.7		2.3		3.3	
Control Power Supply		24 VDC ±5%*2 0.25 A (0.33 A)*1		24 VDC ±5%*2 0.25 A (0.5 A)*1				

* For the geared motor output torque, refer to the speed – torque characteristics.

*1 The brackets () indicate the specifications for the product with an electromagnetic brake.

*2 If a 20 m extension cable is used for the electromagnetic brake type, the 24 VDC ±4% specification applies.

Note

● The rotor inertia represents a sum of the inertia of the harmonic gear converted to motor shaft values.

Speed - Torque Characteristics (Reference Value)

AZ46 Gear Ratio 50

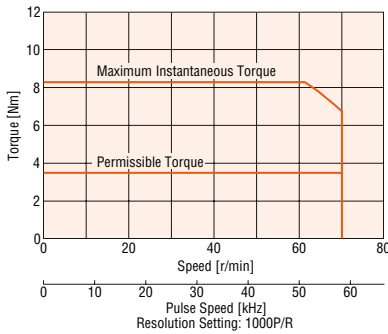

AZ66 Gear Ratio 50

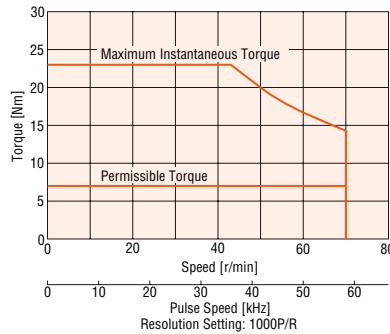

AZ98 Gear Ratio 50

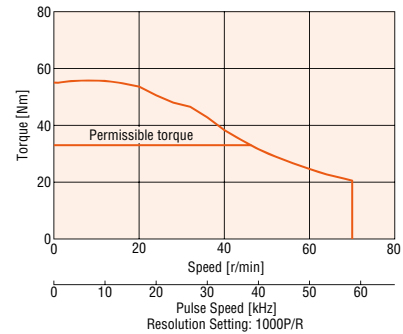

AZ46 Gear Ratio 100

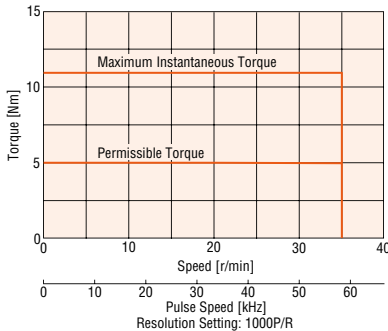

AZ66 Gear Ratio 100

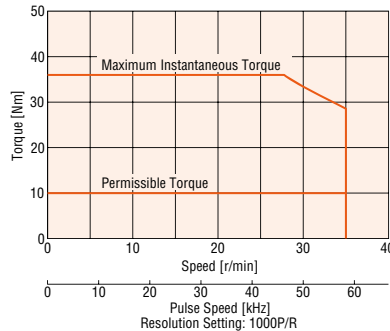

AZ98 Gear Ratio 100

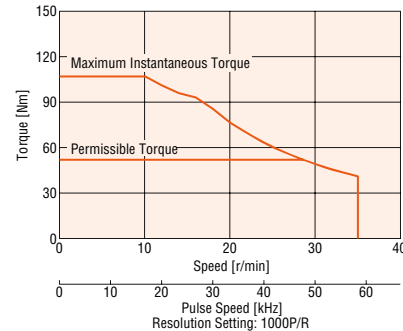

Notes

● The speed-torque characteristics are data based upon our measurement conditions. When these conditions change, these characteristics may change.

● Depending on the driving conditions, a considerable amount of heat may be generated by the motor. Be sure to keep the motor case temperature at 80 °C or less in order to protect the ABZO sensor. (When conforming to the UL standards, it is required to keep the temperature of the motor case at 75 °C or less, since the motor is recognized as thermal class A.)

Driver Specifications

Driver Type	Built-in Controller Type	Pulse-Input Type with RS-485 Communication	Pulse Input Type		
Driver Product Name	AZD-CD	AZD-CX	AZD-C		
I/O Function	Maximum Input Pulse Frequency	–	Line driver output by programmable controller: 1 MHz (When the pulse duty is 50 %) Open-collector output by programmable controller: 250 kHz (When the pulse duty is 50 %) Negative Logic Pulse Input (Initial Value)		
	Number of Positioning Data Sets	256	256 *1		
	Direct Inputs	10	6		
	Direct Outputs		6		
	RS-485 Communication Network Inputs		16	–	
	RS-485 Communication Network Outputs	16	–		
Setting Tool	Data Setting Software MEXEO2		○		
Coordinates Management Method		Battery-free Absolute System			
Operation	Positioning Operation	Positioning Operation	○	○	○*1
		Positioning Push-Motion Operation*2	○	○	○*1
	Connecting Method	Independent Operation	○	○	○*1
		Sequential Operation	○	○	○*1
		Multistep Speed-Change (Configuration Connection)	○	○	○*1
	Sequence Control	Loop Operation (Repeating)	○	○	○*1
		Event Jump Operation	○	○	○*1
	Continuous Operation	Position Control	○	○	○*1
		Speed Control	○	○	○*1
		Torque Control	○	○	○*1
Push-Motion*2		○	○	○*1	
Return-to-home Operation	Return-to-home Operation	○	○	○	
	High Speed Return-to-Home Operation	○	○	○	
JOG Operation		○	○	○	
Monitor/Information	Waveform Monitoring	○	○	○	
	Overload Detection	○	○	○	
	Overheat Detection (Motor/Driver)	○	○	○	
	Position/Speed Information	○	○	○	
	Temperature Detection (Motor/Driver)	○	○	○	
	Motor Load Factor	○	○	○	
Alarm	Traveled Distance / Cumulated Traveled Distance	○	○	○	

*1 This can be used by setting with the data setting software **MEXEO2**.

*2 Push-motion can not be used with a geared motor.

RS-485 Communication Specification

Protocol	Modbus RTU Mode
Electrical Characteristics	EIA-485 Based, Straight Cable Use shielded twisted-pair cables (TIA/EIA-568B CAT5e or better recommended). The max. total extension length is 50 m.
Communication Mode	Half duplex and start-stop synchronization (data: 8 bits, stop bit: 1 bit or 2 bits, parity: none, even, or odd)
Baud Rate	9600 bps/19200 bps/38400 bps/57600 bps/115200 bps/230400 bps are available
Connection Type	Up to 31 units can be connected to a single programmable controller (master equipment).

General Specifications

	Motor	Driver	
		Built-in Controller Type Pulse-Input Type with RS-485 Communication	Pulse Input Type
Heat-resistant Class	130 (B) [UL 105 (A) certified]	-	
Insulation Resistance	100 MΩ or more when a 500 VDC megger is applied between the following places: · Case – Motor Windings · Case – Electromagnetic Brake Windings*1	100 MΩ or more when a 500 VDC megger is applied between the following places: · Protective Earth Terminal – Power Supply Terminal · Encoder Connector – Power Supply Terminal · I/O Signal Terminal – Power Supply Terminal	
Dielectric Voltage	Sufficient to withstand the following for 1 minute: · Case – Motor Windings 1.5 kVAC, 50 Hz or 60 Hz · Case – Electromagnetic Brake Windings*1 1.5 kVAC, 50 Hz or 60 Hz	Sufficient to withstand the following for 1 minute: · Protective Earth Terminal – Power Supply Terminal 1.5 kVAC, 50 Hz or 60 Hz · Encoder Connector – Power Supply Terminal 1.8 kVAC, 50 Hz or 60 Hz · I/O Signal Terminal – Power Supply Terminal 1.8 kVAC, 50 Hz or 60 Hz	
Operating Environment (In operation)	Ambient Temperature	0~+40°C (Non-freezing) *2	
	Ambient Humidity	85% or less (Non-condensing)	
	Atmosphere	No corrosive gases or dust. The product should not be exposed to water, oil or other liquids.	
Degree of Protection	IP66 (excluding installation surfaces and connector locations)	IP10	IP20
Stop Position Accuracy	AZM46, AZM48 : ±4 Minutes (±0.067°)	AZM66, AZM69, AZM98, AZM911 : ±3 Minutes (±0.05°)	
Shaft Runout	0.05 T.I.R. (mm)*4	-	
Concentricity of Installation Pilot to the Shaft	0.075 T.I.R. (mm)*4	-	
Perpendicularity of Installation Surface to the Shaft	0.075 T.I.R. (mm)*4	-	
Multiple Rotation Detection Range Upon Power OFF	±900 Rotation (1,800 Rotations)		

*1 Only for products with an electromagnetic brake.

*2 Based on Oriental Motor's measurement conditions.

*3 When a heat sink of a capacity at least equivalent to an aluminum plate with a size of 200×200 mm and 2 mm thickness.

*4 T. I. R. (Total Indicator Reading): The total dial gauge reading when the measurement section is rotated once around the reference axis center.

Note

- Do not measure insulation resistance or perform a dielectric strength test while the motor and driver are connected. Also, do not perform these tests on the motor absolute sensor part.

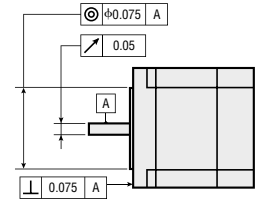

Electromagnetic Brake Specifications

Product Name	AZM46	AZM66	AZM69	AZM98
Type	Power Off Activated Type			
Power Supply Voltage	24 VDC ±5%*			
Power Supply Current	A	0.08	0.25	0.25
Brake Activation Time	ms	20		
Brake Release Time	ms	30		
Time Rating	Continuous			

*If a 20 m extension cable is used for the electromagnetic brake type, the 24 VDC ±4% specification applies.

- The product names are listed such that the product names are identifiable.

Rotation Direction

This refers to the direction viewed from the output shaft side.

The rotation direction of the gear output shaft with respect to the standard type motor output shaft differs depending on the type of gear and gear ratio. Refer to the following table.

Type	Gear Ratio	Rotation Direction with Respect to Motor Output Shaft
TS Geared Type	3.6, 7.2, 10	Same direction
	20, 30	Opposite direction
FC Geared Type PS Geared Type HPG Geared Type	All gear ratios	Same direction
Harmonic Geared Type	All gear ratios	Opposite direction

- Standard Type Motor

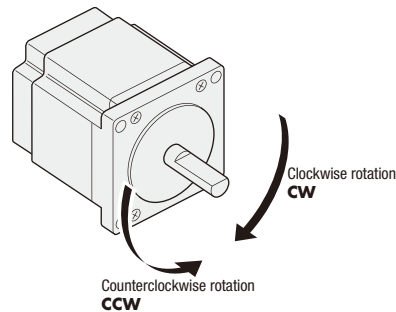

Permissible Radial Load and Permissible Axial Load

Unit: N

	Motor Frame Size [mm]	Product	Gear Ratio	Permissible Radial Load					Permissible Axial Load
				Distance from Shaft End [mm]					
				0	5	10	15	20	
Standard	42	AZM46	-	35	44	58	85	-	15
		AZM48		30	35	44	58	85	
	60	AZM66, AZM69		90	100	130	180	270	30
	85	AZM98, AZM911		260	290	340	390	480	60
TS Geared	42	AZM46	3.6, 7.2, 10	20	30	40	50	-	15
			20, 30	40	50	60	70	-	
	60	AZM66	3.6, 7.2, 10	120	135	150	165	180	40
			20, 30	170	185	200	215	230	
	90	AZM98	3.6, 7.2, 10	300	325	350	375	400	150
			20, 30	400	450	500	550	600	
FC Geared	42	AZM46	7.2, 10, 20, 30	180	200	220	250	-	100
	60	AZM66		270	290	310	330	-	200
PS Geared	42	AZM46	5	70	80	95	120	-	100
			7.2	80	90	110	140	-	
			10	85	100	120	150	-	
			25	120	140	170	210	-	
			36	130	160	190	240	-	
			50	150	170	210	260	-	
	60	AZM66	5	170	200	230	270	320	200
			7.2	200	220	260	310	370	
			10	220	250	290	350	410	
			25	300	340	400	470	560	
			36	340	380	450	530	630	
			50	380	430	500	600	700	
	90	AZM98	5	380	420	470	540	630	600
			7.2	430	470	530	610	710	
			10	480	530	590	680	790	
			25	650	720	810	920	1070	
			36	730	810	910	1040	1210	
			50	820	910	1020	1160	1350	
HPG Geared	40	AZM46	5	150	170	190	230	270	430
			9	180	200	230	270	320	510
	60	AZM66	5	250	270	300	330	360	700
			15	360	380	420	460	510	980
	90	AZM98	5	600	630	670	710	750	1460
			15	830	880	930	980	1050	2030
Harmonic Geared	42	AZM46	50, 100	180	220	270	360	510	220
	60	AZM66		320	370	440	550	720	450
	90	AZM98		1090	1150	1230	1310	1410	1300

- The products can be identified with the detailed product code.
- The PS geared type, PN geared type, and HPG geared type have a full lifetime of 20,000 hours when either the permissible radial load or the permissible axial load is applied. For TS and Harmonic geared types lifetime please contact the nearest Oriental Motor sales office.

Radial Load and Axial Load

Distance from Shaft End [mm]

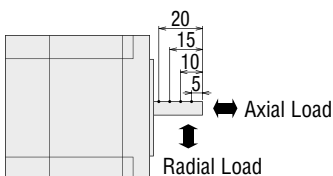

Permissible Moment Load

If an excentric load is applied when attaching an arm or table to the flange face, calculate the moment load with the following formula. The moment load should not exceed the permissible values shown in the table below.

HPG Geared Type Flange Output Type

Product Name	Gear Ratio	Permissible Axial Load [N]	Permissible Moment Load [N·m]	Coefficient a [m]
AZM46	5	430	4.9	0.006
	9	510	5.9	
AZM66	5	700	12.0	0.011
	15	980	17.2	
AZM98	5	1460	38.7	0.0115
	15	2030	53.5	

m : Work mass [kg]
 g : Gravitational acceleration [m/s²]
 F : External force [N]
 L : Distance from center of output flange
 a : Coefficient [m]
 ΔF : Load on output flange side [N]
 F_s : Permissible axial load [N]
 ΔM : Moment load [N·m]
 M : Permissible moment load [N·m]

The required moment load can be calculated according to the following formula.

Example 1: When external force F (N) is applied at a distance of L (m) from the centre of the output flange

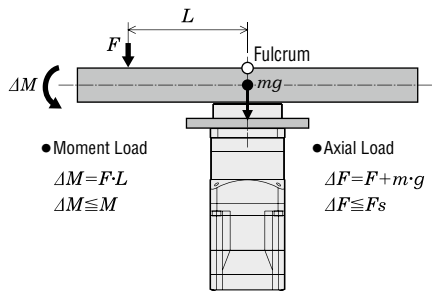

Example 2: When external force F (N) is applied at a distance of L (m) from the surface mounting of the output flange

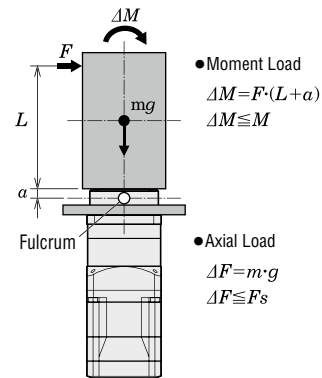

Harmonic Geared Type

Product Name	Permissible Axial Load [N]	Permissible Moment Load [N·m]	Coefficient a [m]
AZM46	220	5.6	0.009
AZM66	450	11.6	0.0114

The required moment load can be calculated according to the following formula.

Example 1: When external force F (N) is applied at a distance of L (m) from the centre of the output flange

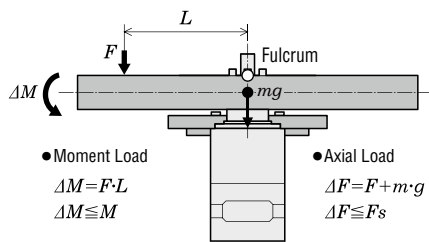

Example 2: When external force F (N) is applied at a distance of L (m) from the surface mounting of the output flange

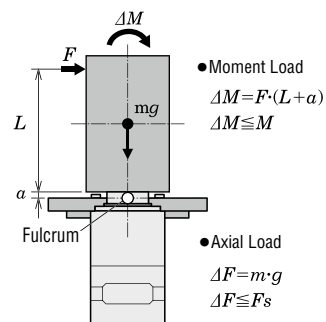

Load Torque - Driver Input Current Characteristics

The following are the relationships between the load torque and driver input current at each speed when the motor is operated. From these characteristics, it is possible to estimate the current capacity actually required when used with multiple axes. For geared motors, convert to torque and speed at the motor shaft.

$$\text{Motor shaft speed} = \text{Gear output shaft speed} \times \text{Gear ratio [r/min]}$$

$$\text{Motor shaft torque} = \frac{\text{Gear output shaft torque}}{\text{Gear Ratio}} \text{ [N}\cdot\text{m]}$$

Single Phase 200–240 VAC

AZM46□C

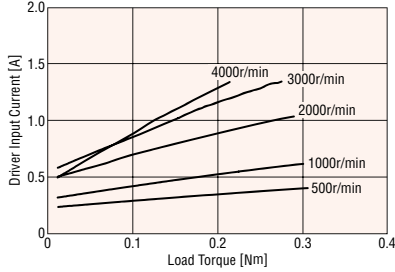

AZM48□C

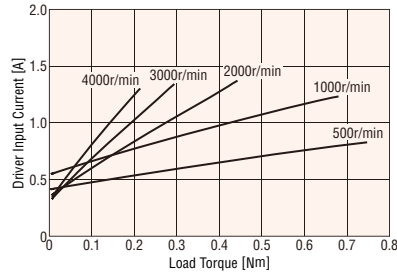

AZM66□C

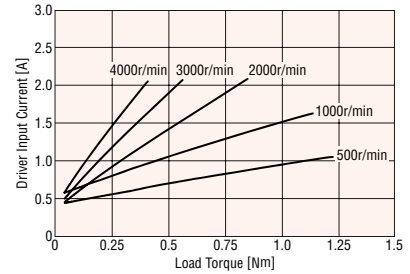

AZM69□C

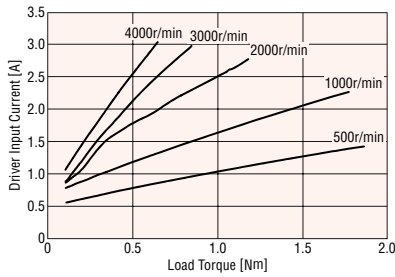

AZM98□C

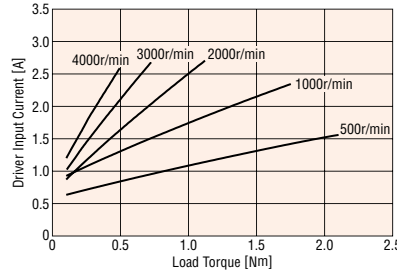

AZM911□C

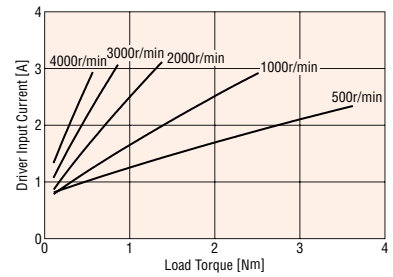

Dimensions (Unit = mm)

Motors

◇ Standard Type

Frame Size 42 mm

Product Name	Mass [kg]
AZM46A□C	0.44

One Side Milled

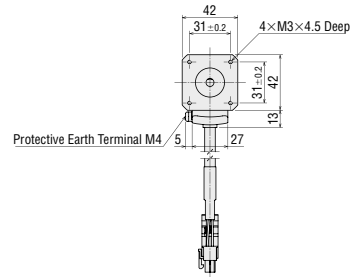
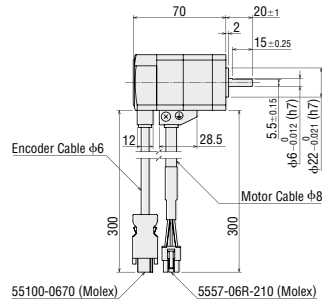

Straight

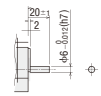

Frame Size 42 mm

Product Name	Mass [kg]
AZM48A□C	0.68

One Side Milled

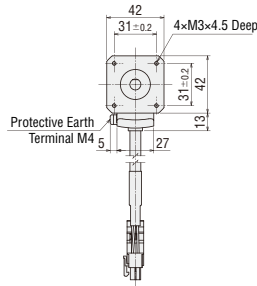
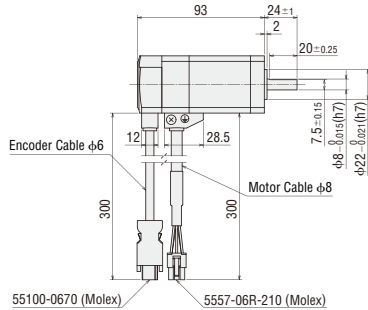

Straight

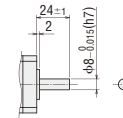

With Key

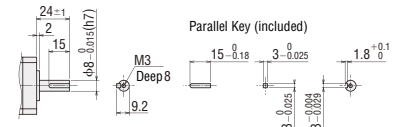

Frame Size 60 mm

Product Name	L	Mass [kg]
AZM66A□C	72	0.91
AZM69A□C	97.5	1.4

One Side Milled

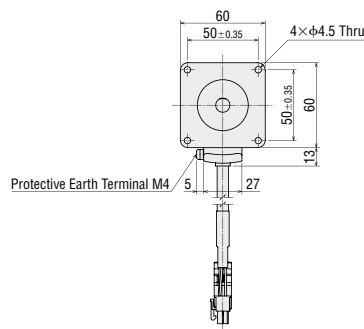
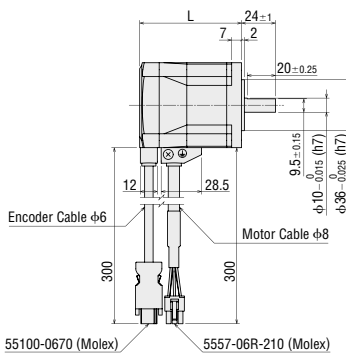

Straight

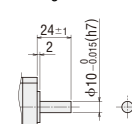

With Key

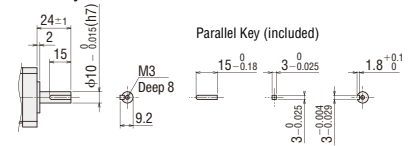

● Either **0** (straight) or **1** (with key) indicating the shaft shape is entered where the box □ is located within the product name. (For **AZM46** straight only).

Frame Size 85 mm

Product Name	L	Mass [kg]
AZM98A □C	84	1.9
AZM911A □C	114	3

One Side Milled

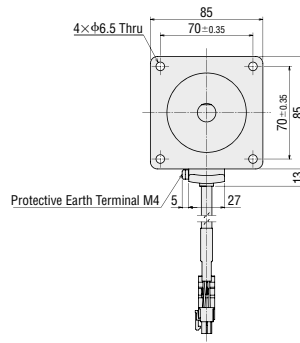
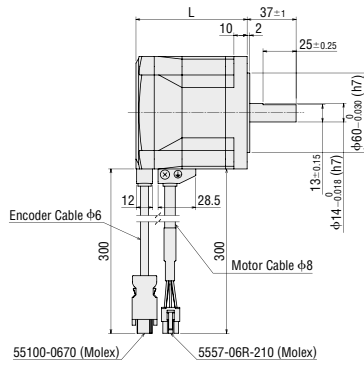

Straight

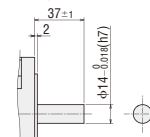

With Key

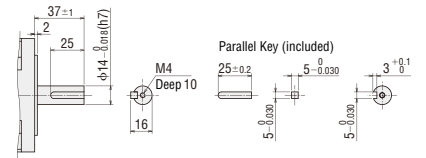

◇ Standard Type with Electromagnetic Brake

Frame Size 42 mm

Product Name	Mass [kg]
AZM46M □C	0.61

One Side Milled

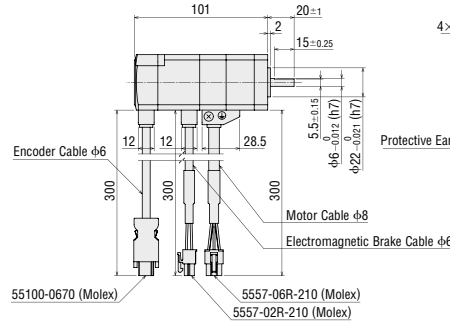
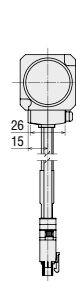

Straight

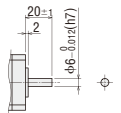

Frame Size 60 mm

Product Name	L	Mass [kg]
AZM66M □C	118	1.3
AZM69M □C	143.5	1.8

One Side Milled

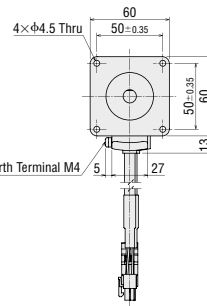
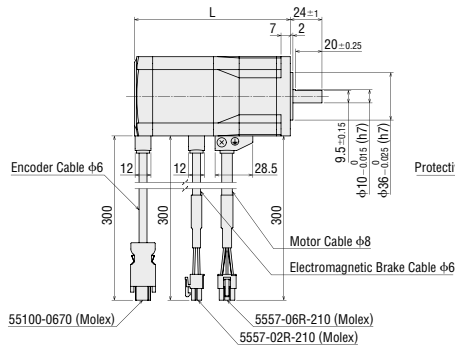
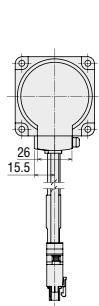

Straight

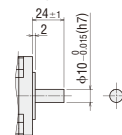

With Key

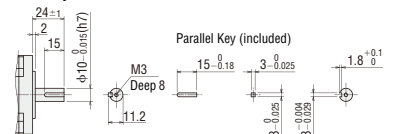

● Either 0 (straight) or 1 (with key) indicating the shaft shape is entered where the box □ is located within the product name. (For **AZM46** straight only).

Frame Size 85 mm

Product Name	Mass [kg]
AZM98M □C	2.5

One Side Milled

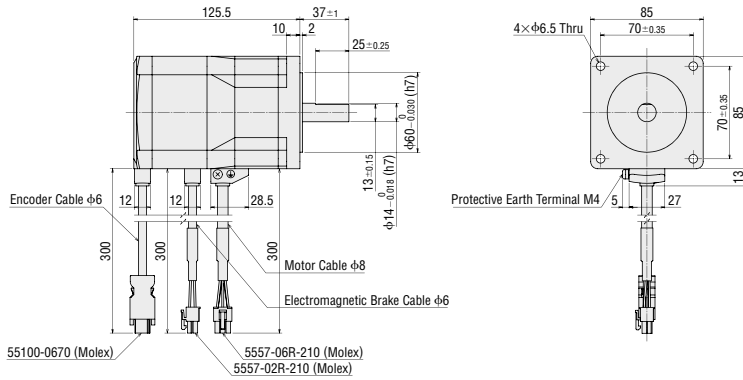

Straight

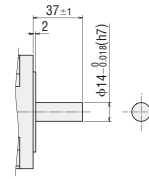

With Key

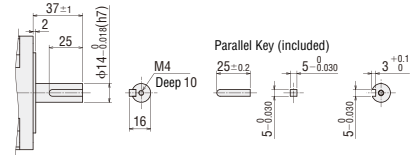

◇ TS Geared Type

Frame Size 42 mm

Product Name	Gear Ratio	Mass [kg]
AZM46AC-TS □◇	3.6, 7.2, 10, 20, 30	0.59

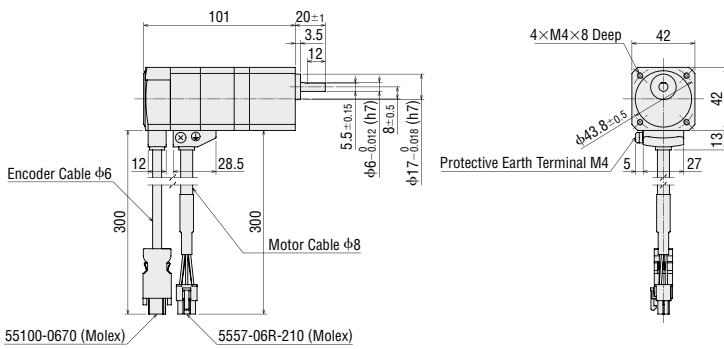

● Cable Direction

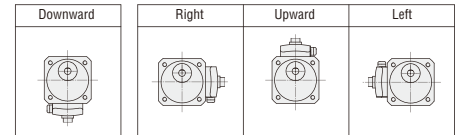

Frame Size 60 mm

Product Name	Gear Ratio	Mass [kg]
AZM66AC-TS □◇	3.6, 7.2, 10, 20, 30	1.3

● Installation screw: M4×60 P0.7 (4 screws included)

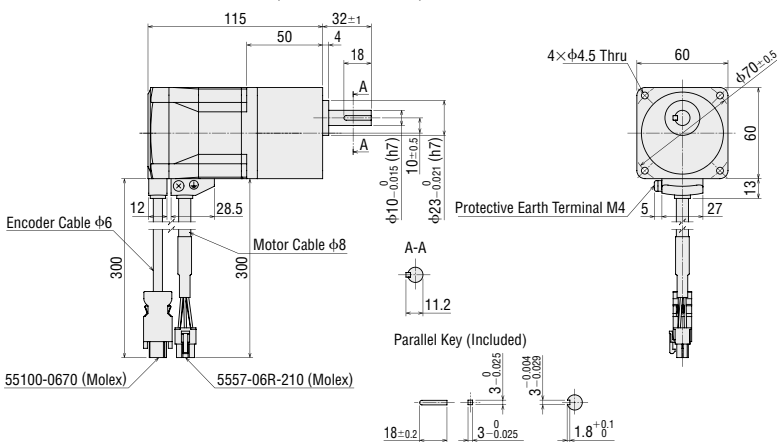

● Cable Direction

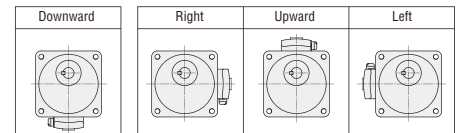

● The **■** within the product name includes a number expressing the gear ratio.

● Either **R** (right), **U** (up) or **L** (left) indicating the cable withdrawing direction is entered where the box **◇** is located within the product name. For downward direction no letter is entered in the box **◇**.

Frame Size 90 mm

Product Name	Gear Ratio	Mass [kg]
AZM98AC-TS 	3.6, 7.2, 10, 20, 30	3.1

● Installation screw: M8×90 P1.25 (4 screws included)

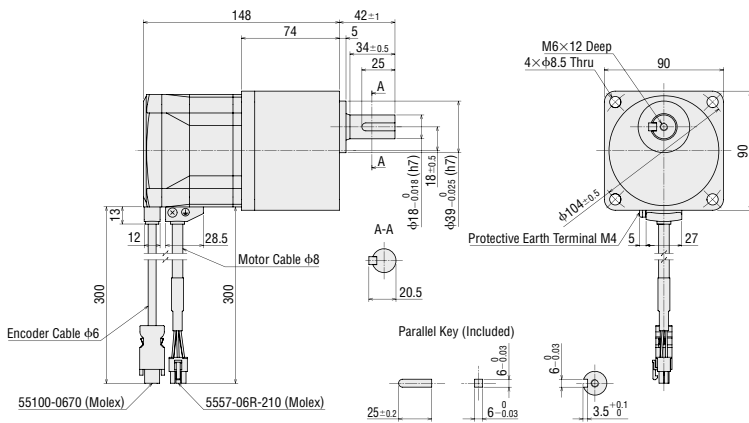

● Cable Direction

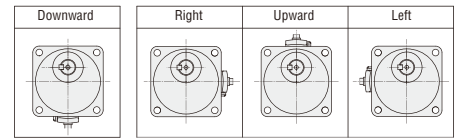

◇ TS Geared Type with Electromagnetic Brake

Frame Size 42 mm

Product Name	Gear Ratio	Mass [kg]
AZM46MC-TS 	3.6, 7.2, 10, 20, 30	0.76

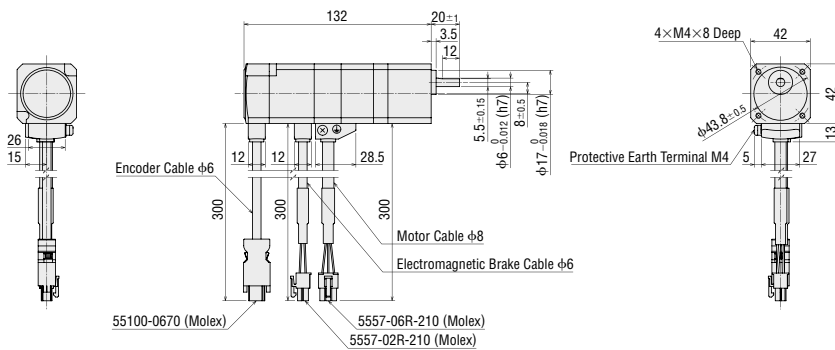

● Cable Direction

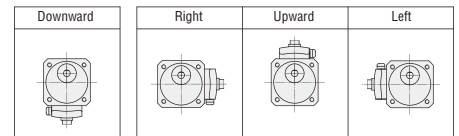

Frame Size 60 mm

Product Name	Gear Ratio	Mass [kg]
AZM66MC-TS 	3.6, 7.2, 10, 20, 30	1.7

● Installation screw: M4×60 P0.7 (4 screws included)

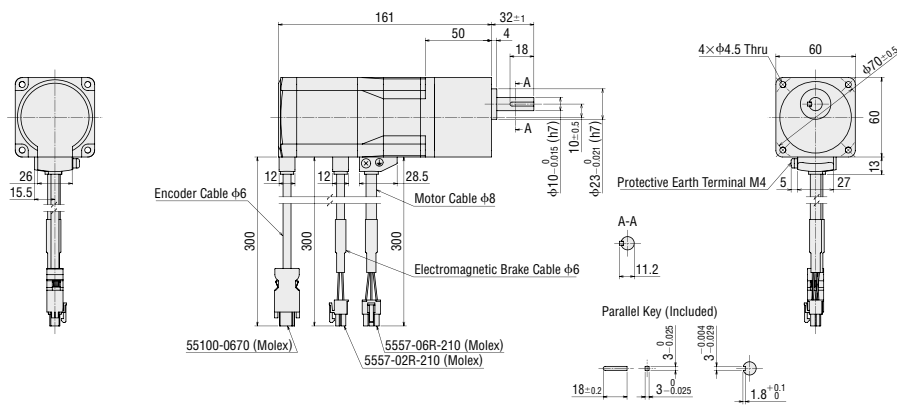

● Cable Direction

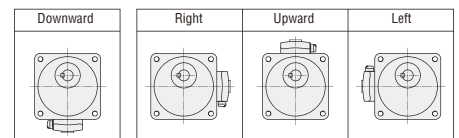

● The within the product name includes a number expressing the gear ratio.

● Either **R** (right), **U** (up) or **L** (left) indicating the cable withdrawing direction is entered where the box is located within the product name. For downward direction no letter is entered in the box .

Frame Size 90 mm

Product Name	Gear Ratio	Mass [kg]
AZM98MC-TS ◊	3.6, 7.2, 10, 20, 30	3.7

● Installation screw: M8×90 P1.25 (4 screws included)

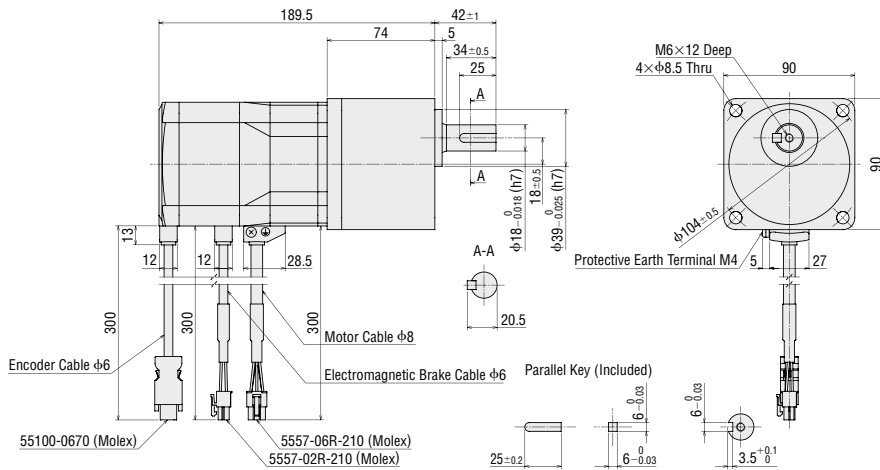

● Cable Direction

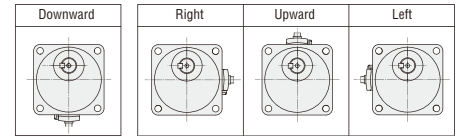

◊ FC Geared Type

Frame Size 42 mm Cable Withdrawing Direction Up

Product Name	Gear Ratio	Mass [kg]
AZM46AC-FC ◻ UA	7.2, 10, 20, 30	0.79

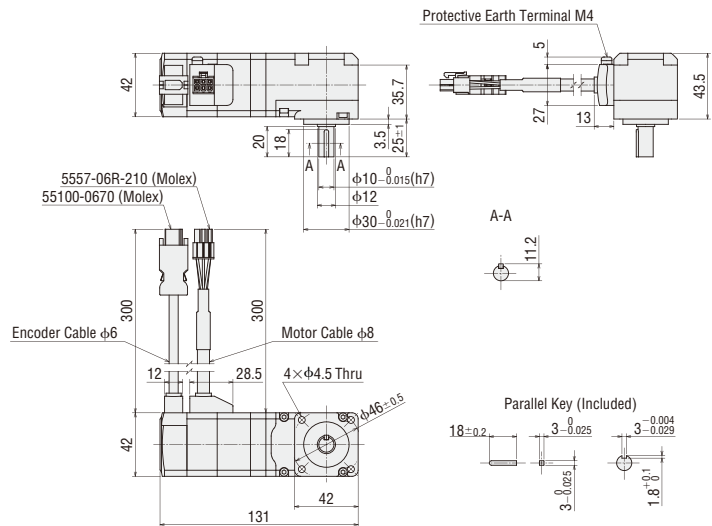

Frame Size 42 mm Cable Withdrawing Direction Down

Product Name	Gear Ratio	Mass [kg]
AZM46AC-FC ◻ DA	7.2, 10, 20, 30	0.79

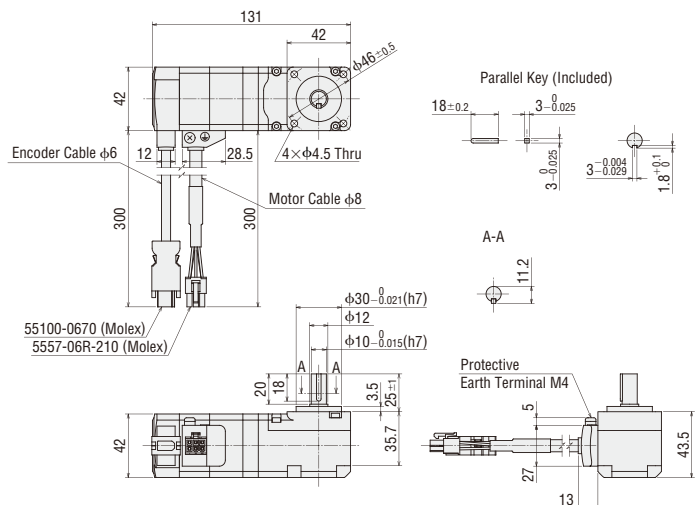

● The ◻ within the product name includes a number expressing the gear ratio.

● Either **R** (right), **U** (up) or **L** (left) indicating the cable withdrawing direction is entered where the box ◊ is located within the product name. For downward direction no letter is entered in the box ◊.

Features

System Configuration

Product Line

Specifications and Features

Dimensions

Connection and Operation

System Configuration

Product Line

Specifications and Features

Dimensions

Connection and Operation

Multiaxis Driver

Accessories

Accessories

Frame Size 60 mm Cable Withdrawing Direction Up

Product Name	Gear Ratio	Mass [kg]
AZM66AC-FC ■ UA	7.2, 10, 20, 30	1.8

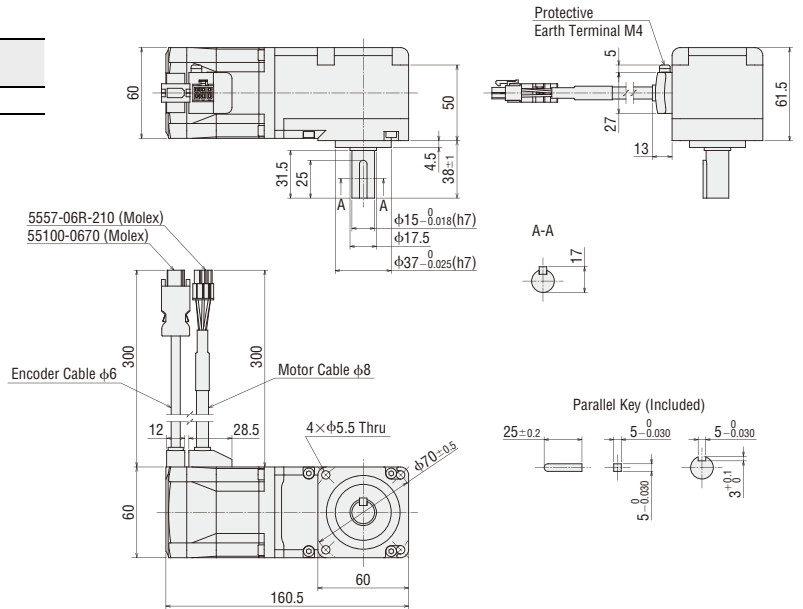

Frame Size 60 mm Cable Withdrawing Direction Down

Product Name	Gear Ratio	Mass [kg]
AZM66AC-FC ■ DA	7.2, 10, 20, 30	1.8

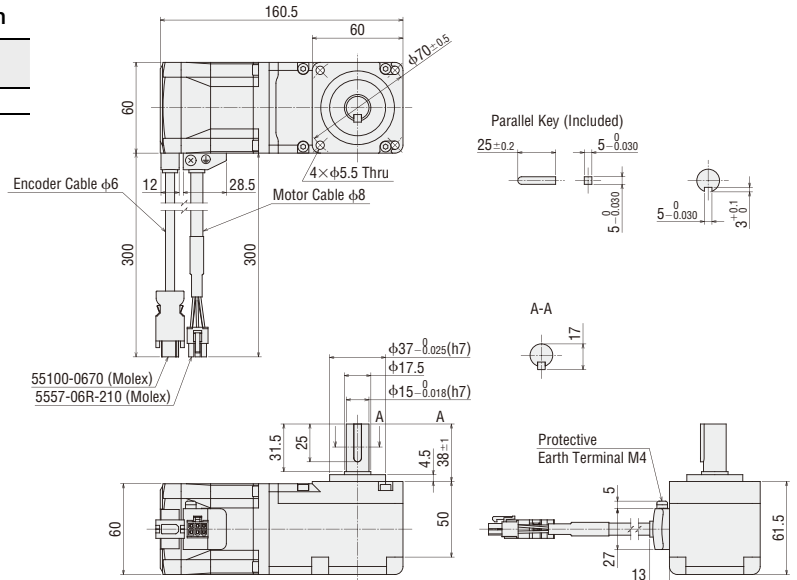

◇ FC Geared Type with Electromagnetic Brake
Frame Size 42 mm Cable Withdrawing Direction Up

Product Name	Gear Ratio	Mass [kg]
AZM46MC-FC ■ UA	7.2, 10, 20, 30	0.96

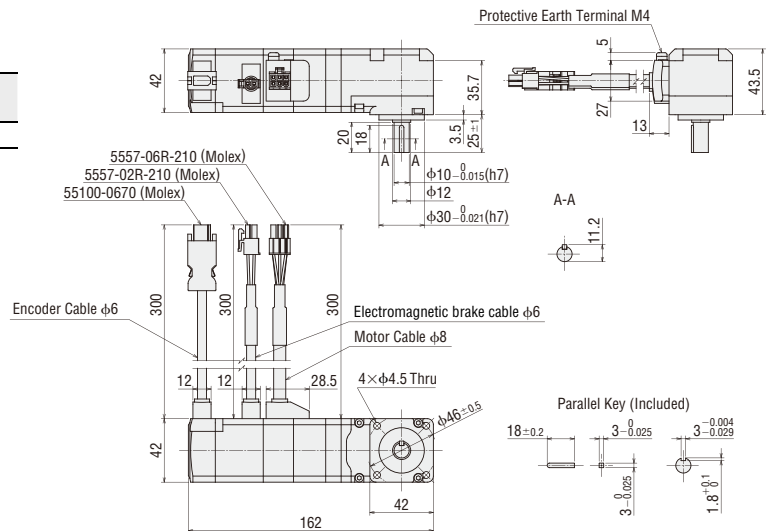

● The ■ within the product name includes a number expressing the gear ratio.

Frame Size 42 mm Cable Withdrawing Direction Down

Product Name	Gear Ratio	Mass [kg]
AZM46MC-FC DA	7.2, 10, 20, 30	0.96

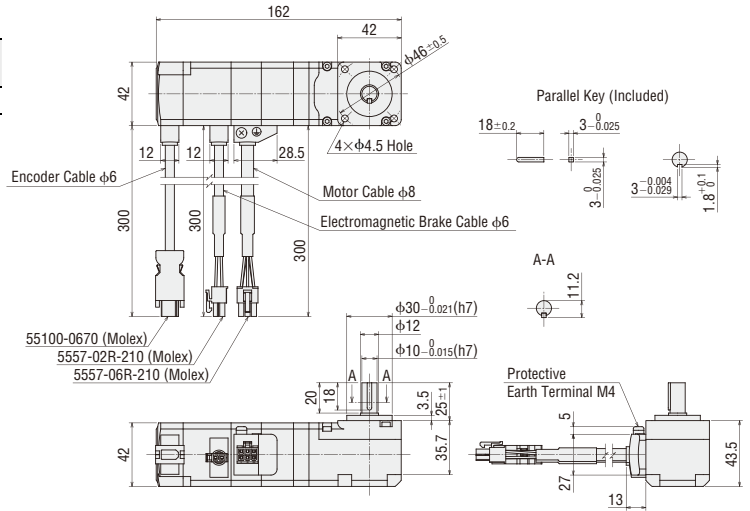

Frame Size 60 mm Cable Withdrawing Direction Up

Product Name	Gear Ratio	Mass [kg]
AZM66MC-FC UA	7.2, 10, 20, 30	2.2

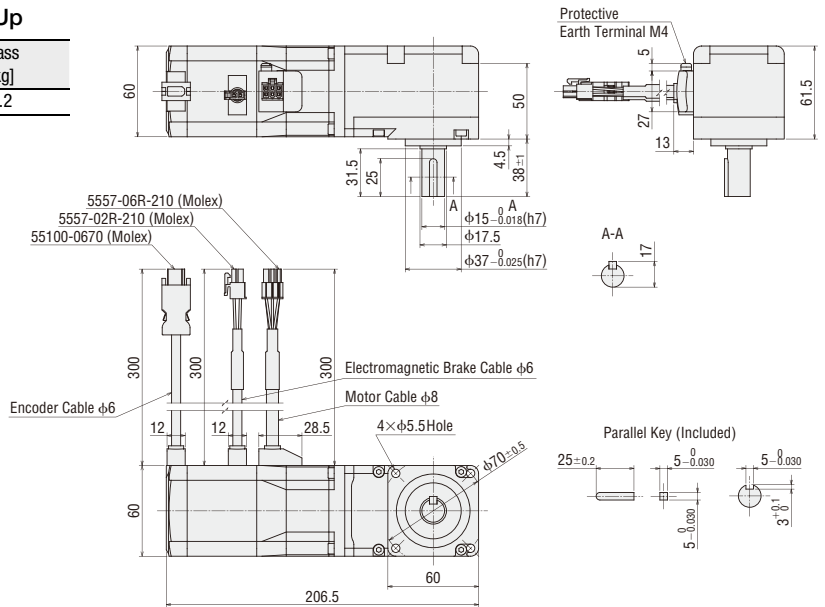

Frame Size 60 mm Cable Withdrawing Direction Down

Product Name	Gear Ratio	Mass [kg]
AZM66AC-MC DA	7.2, 10, 20, 30	2.2

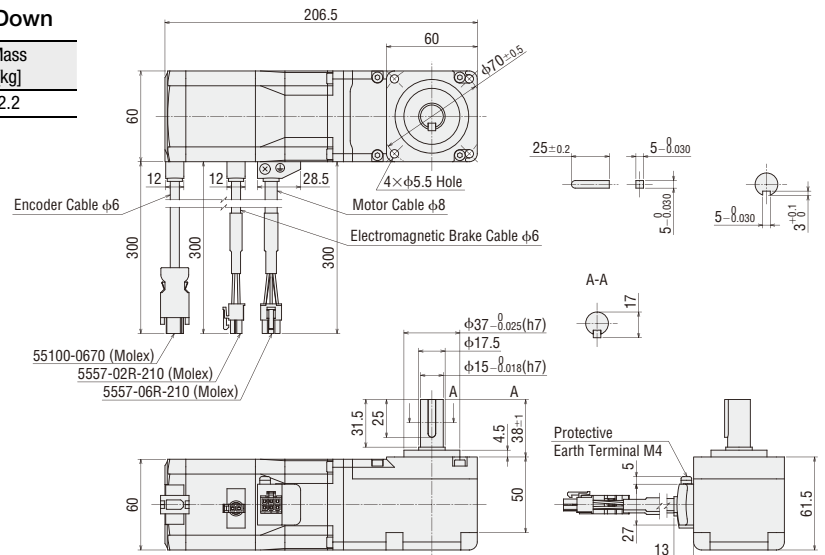

● The within the product name includes a number expressing the gear ratio.

Features	System Configuration	Product Line	Specifications and Features	Dimensions	Connection and Operation	System Configuration	Product Line	Specifications and Features	Dimensions	Connection and Operation	MultiAxis Driver	Accessories
----------	----------------------	--------------	-----------------------------	------------	--------------------------	----------------------	--------------	-----------------------------	------------	--------------------------	------------------	-------------

◇ **PS Geared Type**

Frame Size 42 mm

Product Name	Gear Ratio	L	Mass [kg]
AZM46AC-PS ■	5, 7, 2, 10	98	0.64
	25, 36, 50	121.5	0.79

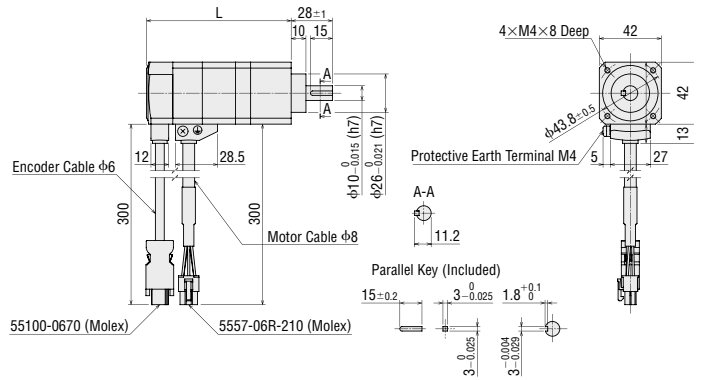

Frame Size 60 mm

Product Name	Gear Ratio	L	Mass [kg]
AZM66AC-PS ■	5, 7, 2, 10	104	1.3
	25, 36, 50	124	1.6

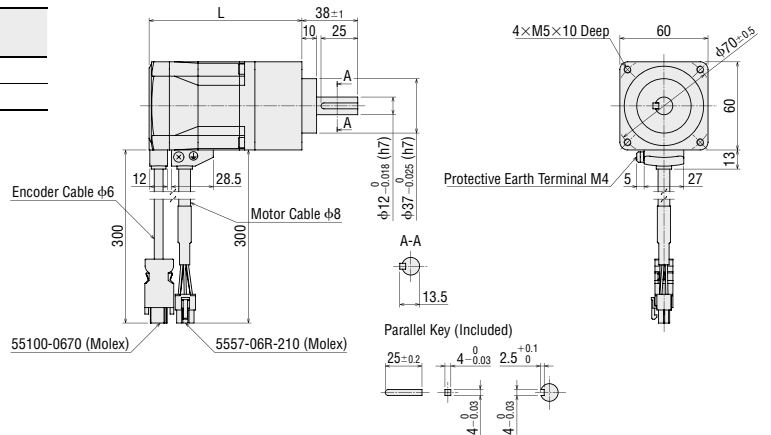

Frame Size 90 mm

Product Name	Gear Ratio	L	Mass [kg]
AZM98AC-PS ■	5, 7, 2, 10	131	3.3
	25, 36, 50	158.5	4.1

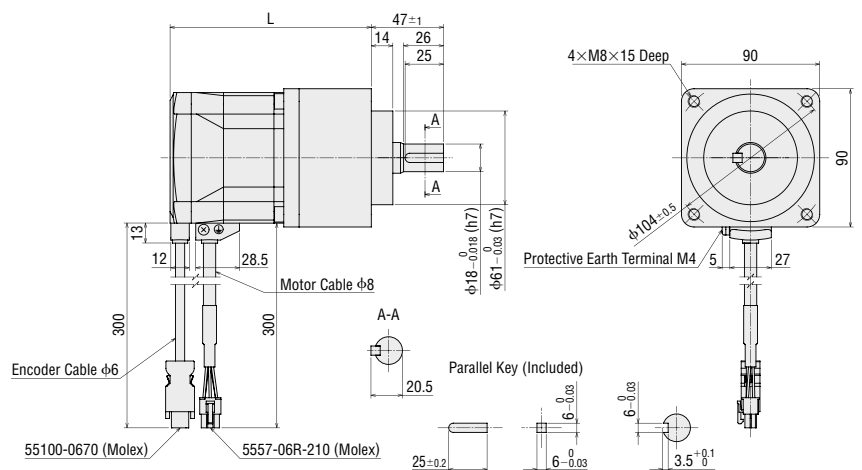

● The ■ within the product name includes a number expressing the gear ratio.

◆ **PS Geared Type with Electromagnetic Brake**
Frame Size 42 mm

Product Name	Gear Ratio	L	Mass [kg]
AZM46MC-PS ■	5, 7.2, 10	129	0.81
	25, 36, 50	152	0.96

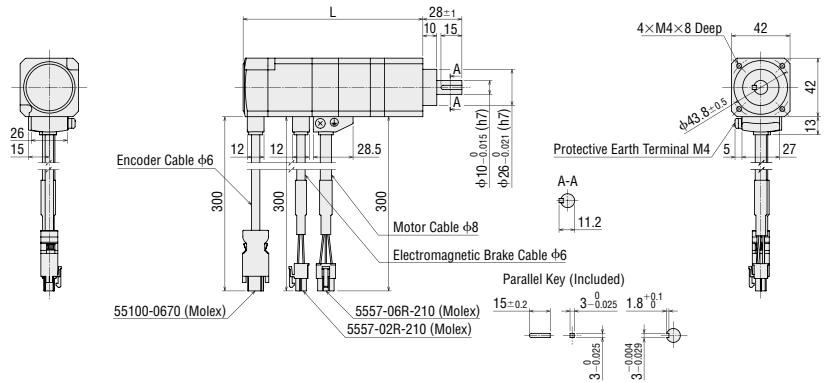

Frame Size 60 mm

Product Name	Gear Ratio	L	Mass [kg]
AZM66MC-PS ■	5, 7.2, 10	150	1.7
	25, 36, 50	170	2.0

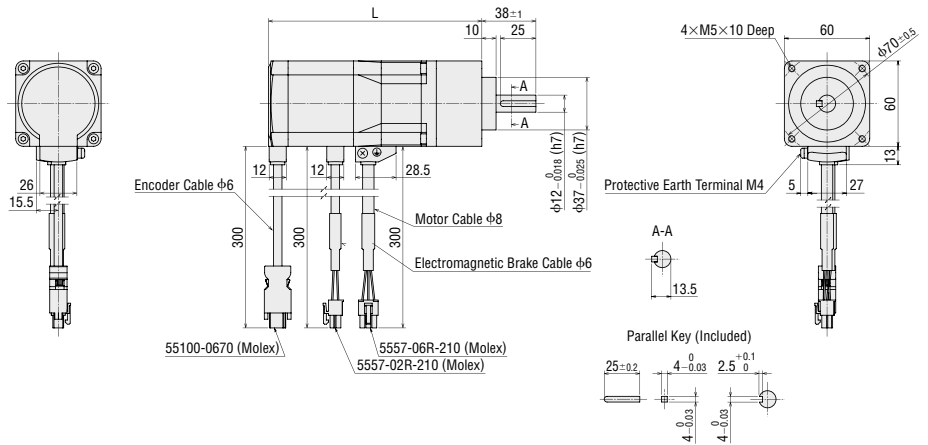

Frame Size 90 mm

Product Name	Gear Ratio	L	Mass [kg]
AZM98MC-PS ■	5, 7.2, 10	172.5	3.9
	25, 36, 50	200	4.7

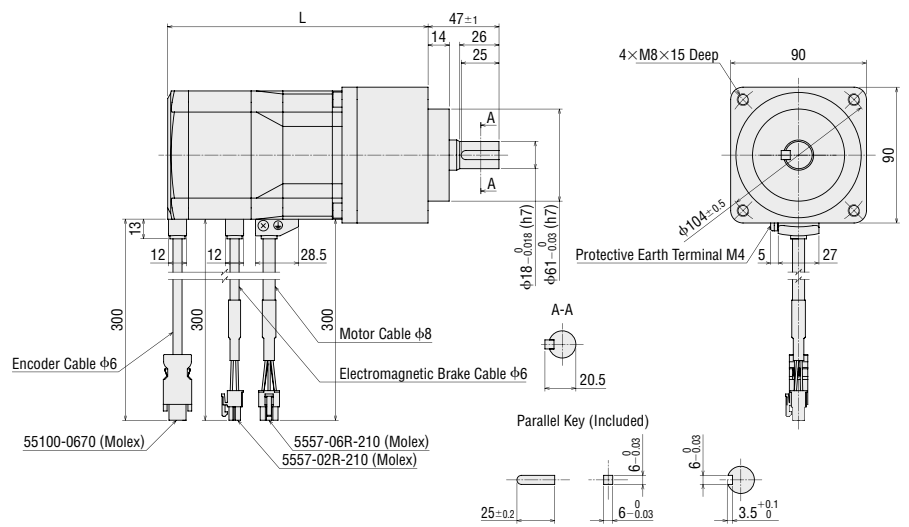

● The ■ within the product name includes a number expressing the gear ratio.

Features
System Configuration
Product Line
Specifications and Features
AC Input
Dimensions
Connection and Operation
System Configuration
Product Line
Specifications and Features
DC Input
Dimensions
Connection and Operation
Multi-axis Driver
Accessories

◆ **HPG** Geared Type Shaft Output Type
Frame Size 40 mm

Product Name	Gear Ratio	Mass [kg]
AZM46AC-HP ■	5, 9	0.71

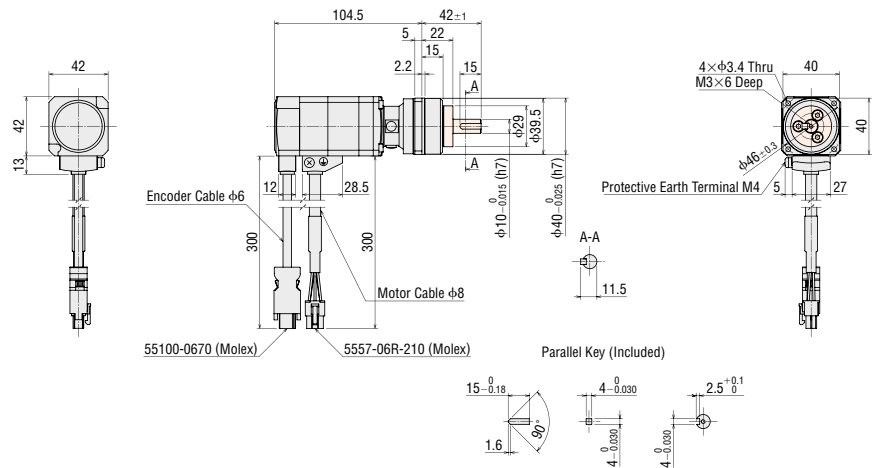

Frame Size 60 mm

Product Name	Gear Ratio	Mass [kg]
AZM66AC-HP ■	5, 15	1.9

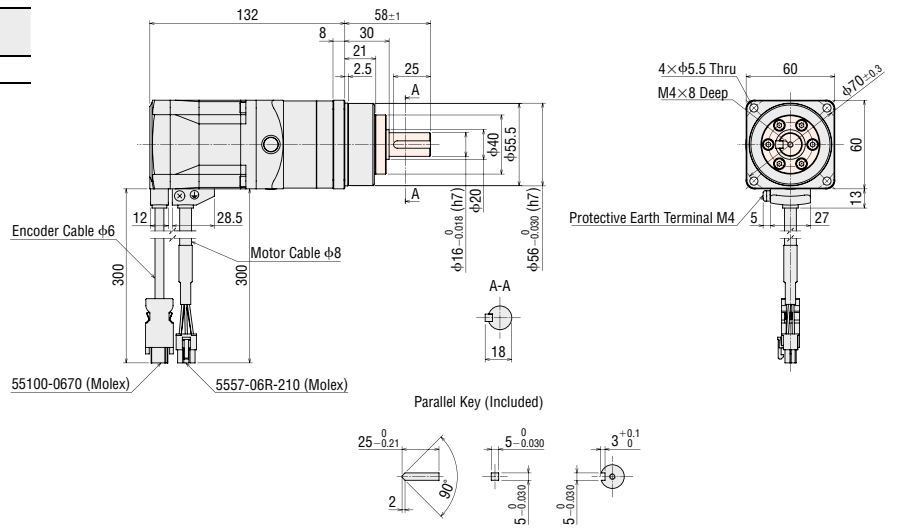

Frame Size 90 mm

Product Name	Gear Ratio	Mass [kg]
AZM98AC-HP ■	5, 15	4.8

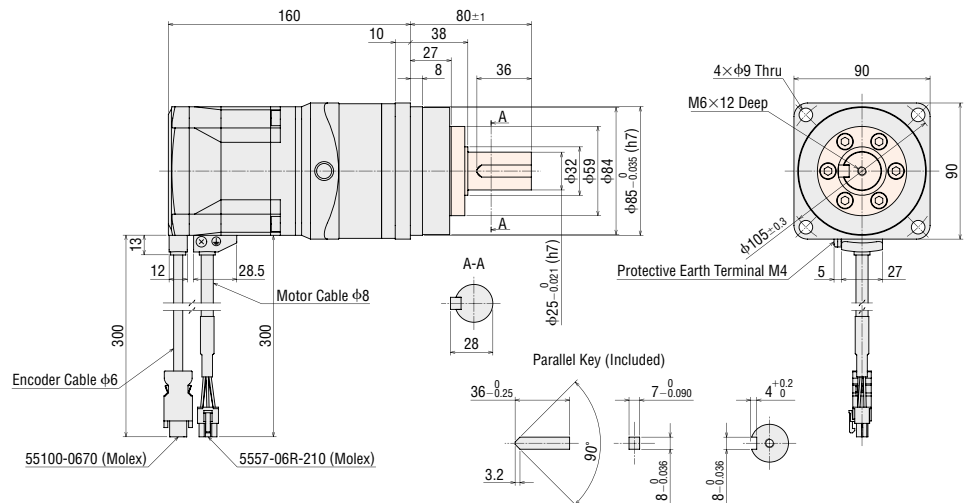

- The coloured part of the outline drawing is the rotation section.
- The ■ within the product name includes a number expressing the gear ratio.

◆ **HPG Geared Type Flange Output Type**
Frame Size 40 mm

Product Name	Gear Ratio	Mass [kg]
AZM46AC-HP ■F	5, 9	0.66

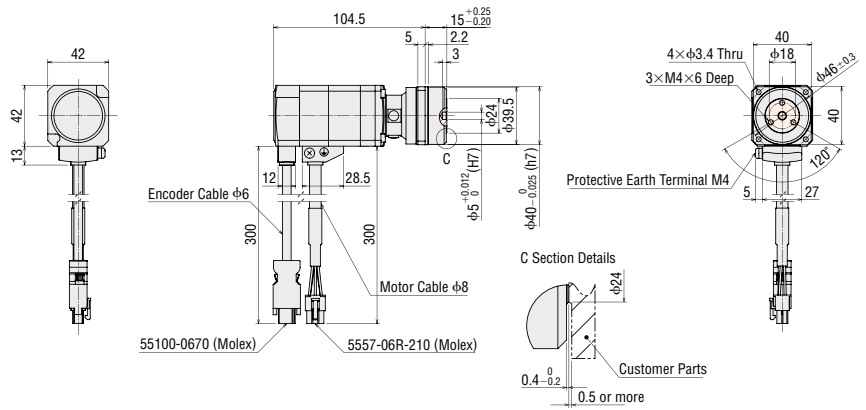

Frame Size 60 mm

Product Name	Gear Ratio	Mass [kg]
AZM66AC-HP ■F	5, 15	1.8

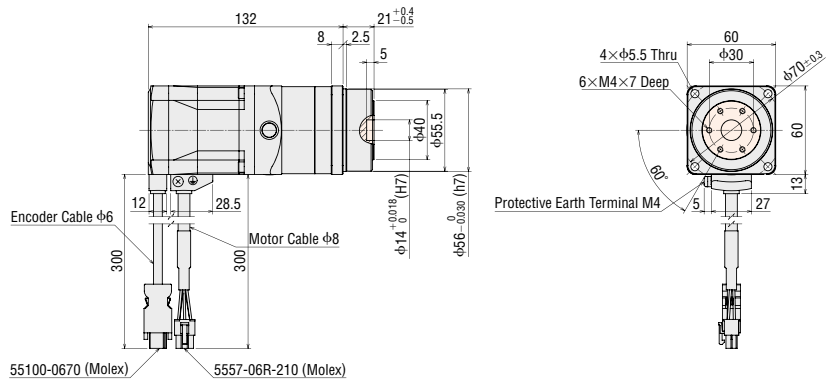

Frame Size 90 mm

Product Name	Gear Ratio	Mass [kg]
AZM98AC-HP ■F	5	4.5
	15	4.4

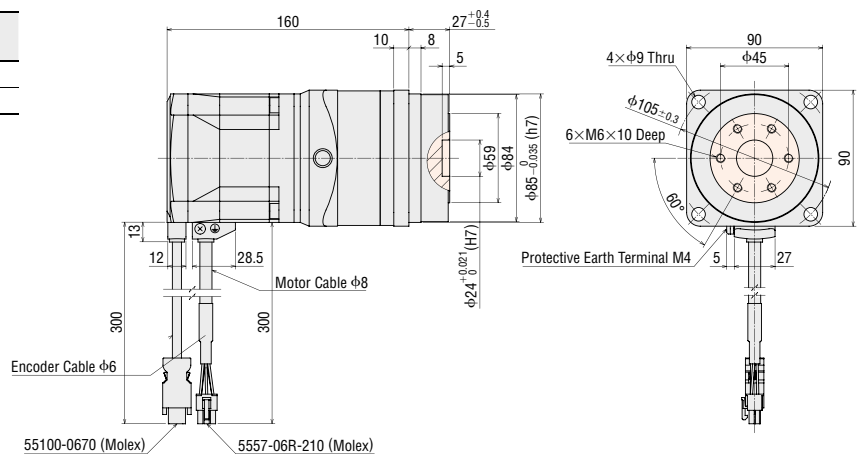

- The coloured part of the outline drawing is the rotation section.
- The ■ within the product name includes a number expressing the gear ratio.

Features
System Configuration
Product Line
Specifications and Features
AC Input
Dimensions
Connection and Operation
System Configuration
Product Line
Specifications and Features
DC Input
Dimensions
Connection and Operation
Multiaxis Driver
Accessories

◆ **HPG** Geared Type with Electromagnetic Brake Shaft Output Type
 Frame Size 40 mm

Product Name	Gear Ratio	Mass [kg]
AZM46MC-HP ■	5, 9	0.88

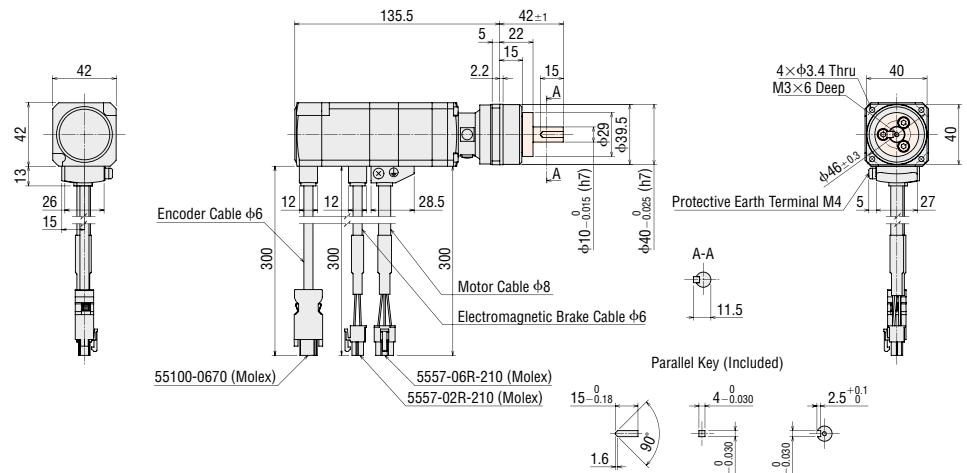

Frame Size 60 mm

Product Name	Gear Ratio	Mass [kg]
AZM66MC-HP ■	5, 15	2.3

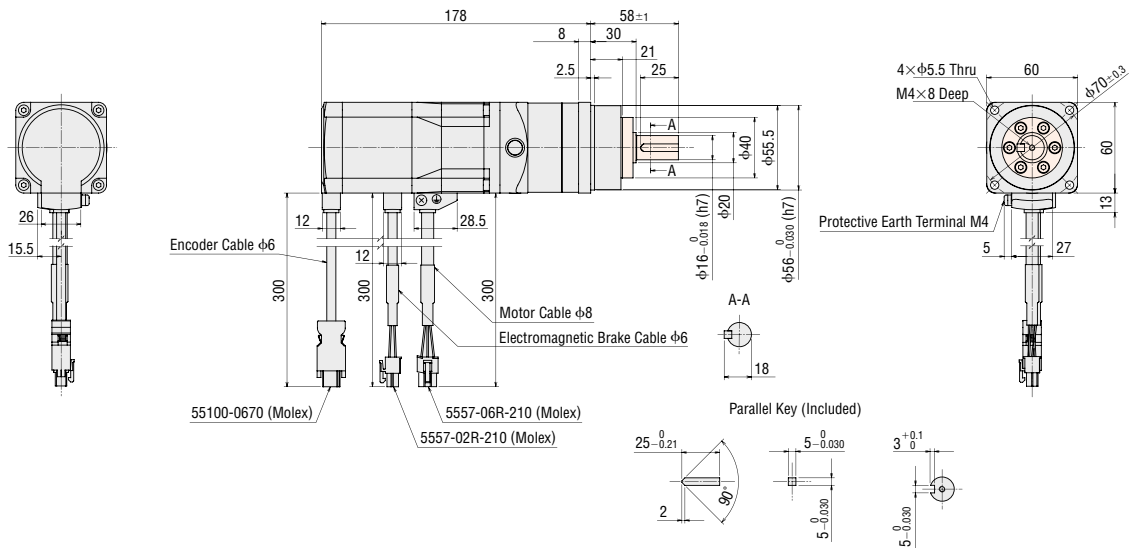

Frame Size 90 mm

Product Name	Gear Ratio	Mass [kg]
AZM98MC-HP ■	5, 15	5.4

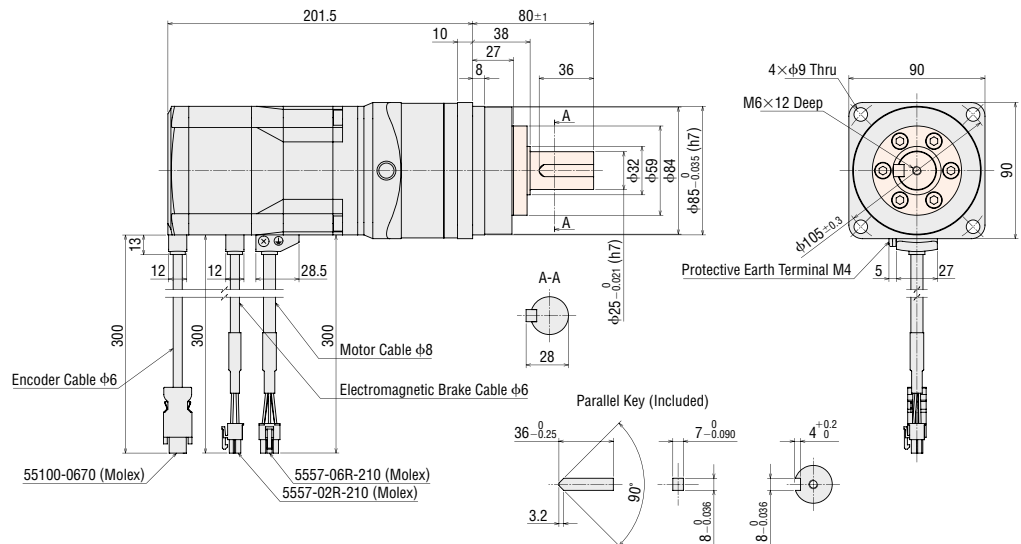

- The coloured part of the outline drawing is the rotation section.
- The ■ within the product name includes a number expressing the gear ratio.

◆ **HPG Geared Type with Electromagnetic Brake Flange Output Type**
Frame Size 40 mm

Product Name	Gear Ratio	Mass [kg]
AZM46MC-HP ■F	5, 9	0.83

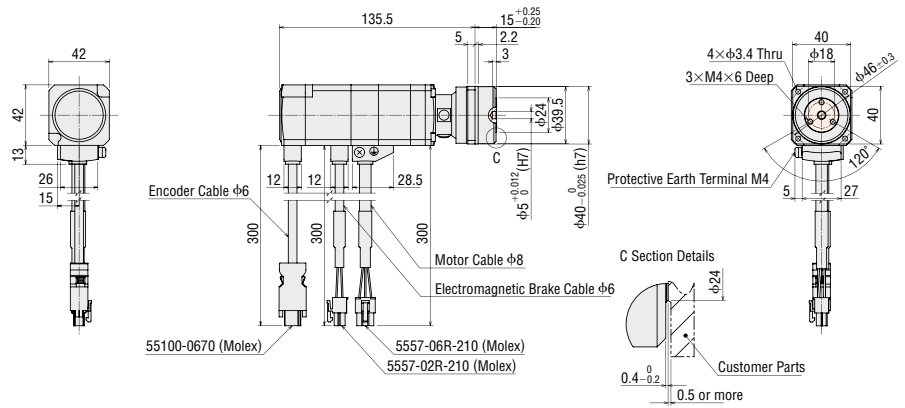

Frame Size 60 mm

Product Name	Gear Ratio	Mass [kg]
AZM66MC-HP ■F	5, 15	2.2

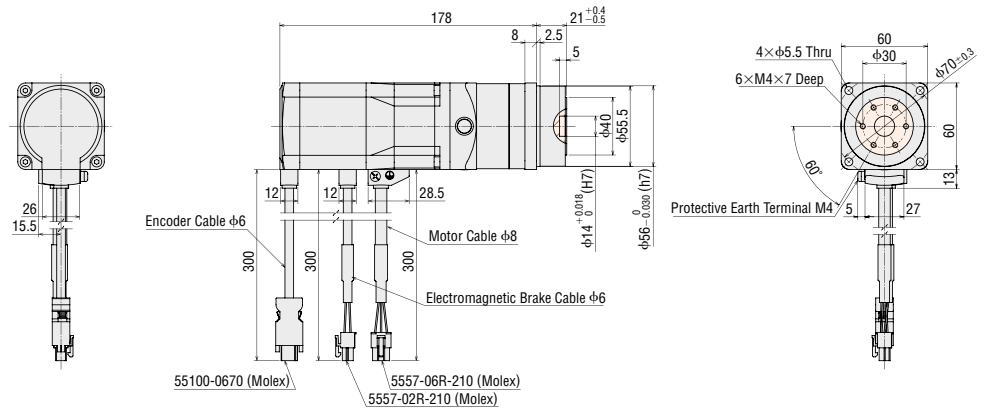

Frame Size 90 mm

Product Name	Gear Ratio	Mass [kg]
AZM98MC-HP ■F	5	5.1
	15	5

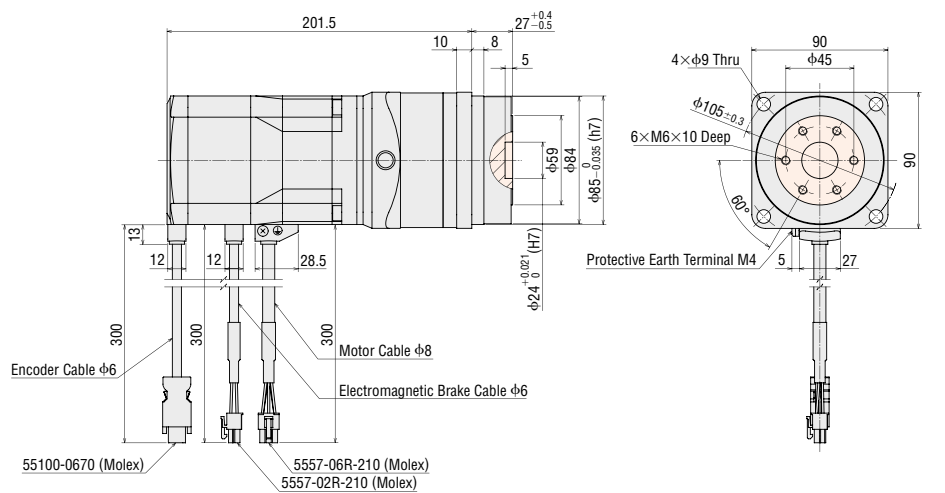

- The coloured part of the outline drawing is the rotation section.
- The ■ within the product name includes a number expressing the gear ratio.

Features
System Configuration
Product Line
Specifications and Features
AC Input
Dimensions
Connection and Operation
System Configuration
Product Line
Specifications and Features
DC Input
Dimensions
Connection and Operation
Multiaxis Driver
Accessories

◇ Harmonic Geared Type

Frame Size 42 mm

Product Name	Gear Ratio	Mass [kg]
AZM46AC-HS ■	50, 100	0.65

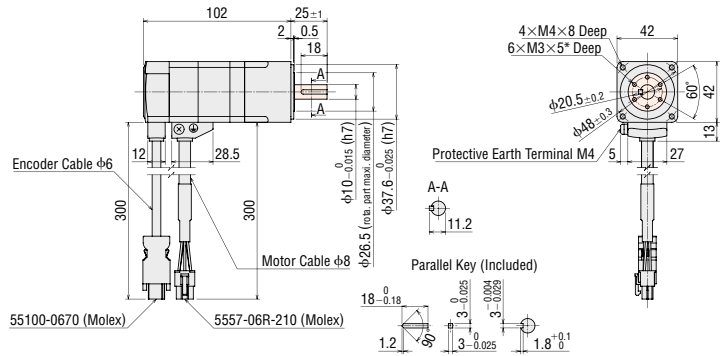

*The position of the output shaft relative to the screw holes on the rotating part cannot be specified. Adjust the position via the size of the screw holes on the load installation surface.

Frame Size 60 mm

Product Name	Gear Ratio	Mass [kg]
AZM66AC-HS ■	50, 100	1.4

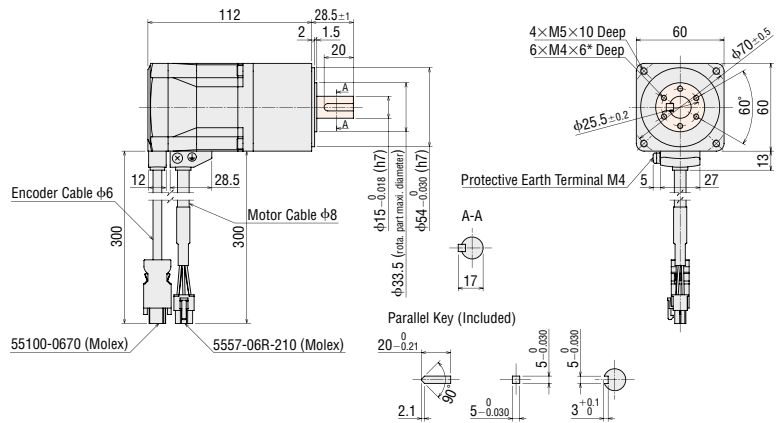

*The position of the output shaft relative to the screw holes on the rotating part cannot be specified. Adjust the position via the size of the screw holes on the load installation surface.

Frame Size 90 mm

Product Name	Gear Ratio	Mass [kg]
AZM98AC-HS ■	50, 100	3.9

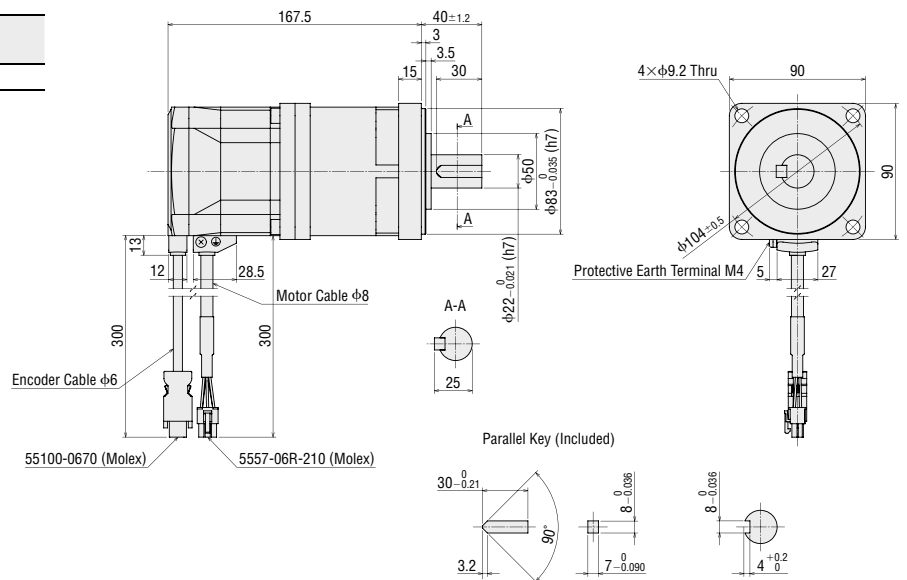

- The coloured part ■ of the outline drawing is the rotation section.
- The ■ within the product name includes a number expressing the gear ratio.

◇ Harmonic Geared Type with Electromagnetic Brake
Frame Size 42 mm

Product Name	Gear Ratio	Mass [kg]
AZM46MC-HS ■	50, 100	0.82

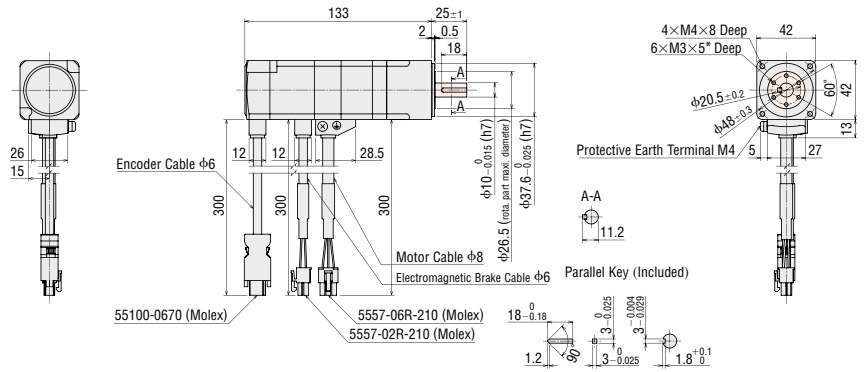

*The position of the output shaft relative to the screw holes on the rotating part cannot be specified. Adjust the position via the size of the screw holes on the load installation surface.

Frame Size 60 mm

Product Name	Gear Ratio	Mass [kg]
AZM66MC-HS ■	50, 100	1.8

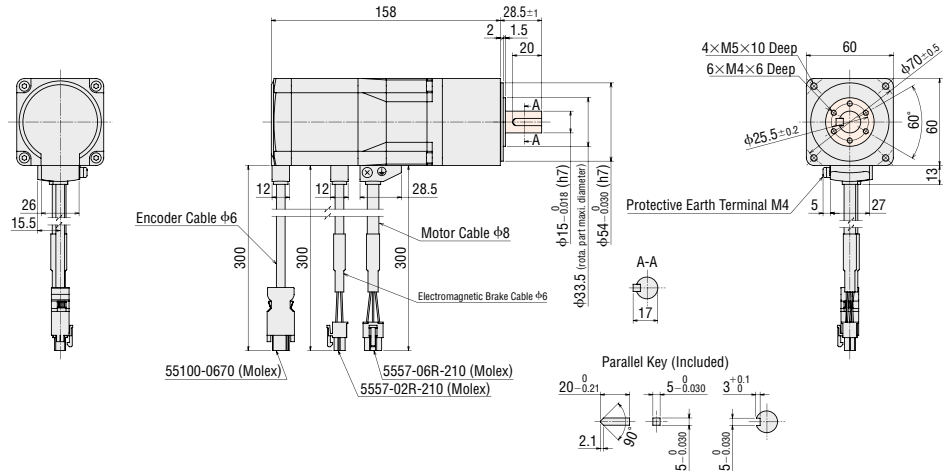

*The position of the output shaft relative to the screw holes on the rotating part cannot be specified. Adjust the position via the size of the screw holes on the load installation surface.

Frame Size 90 mm

Product Name	Gear Ratio	Mass [kg]
AZM98MC-HS ■	50, 100	4.5

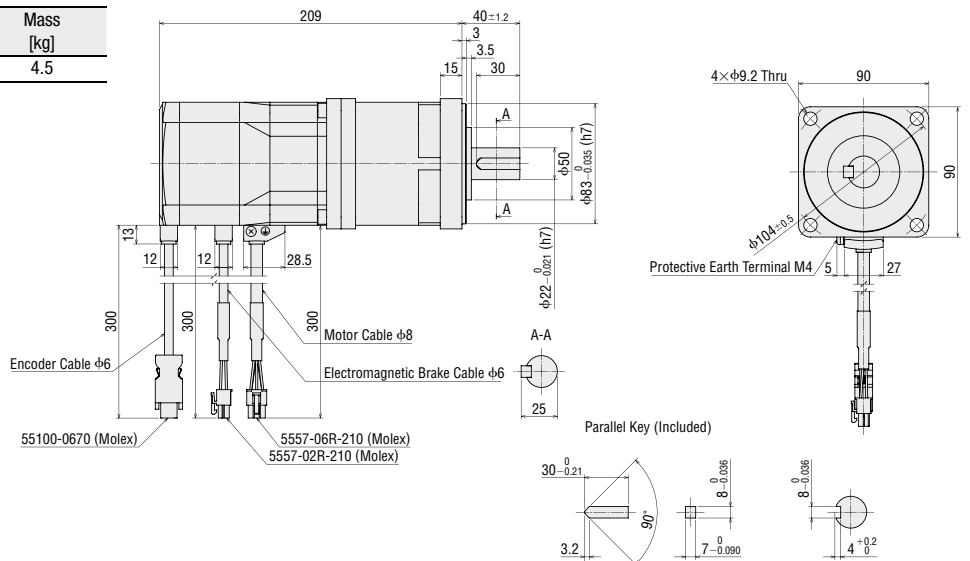

- The coloured part ■ of the outline drawing is the rotation section.
- The ■ within the product name includes a number expressing the gear ratio.

● Drivers

◇ Built-in Controller Type, Pulse-Input Type with RS-485 Communication

Driver Product Name: **AZD-CD, AZD-CX**

Mass: 0.65 kg

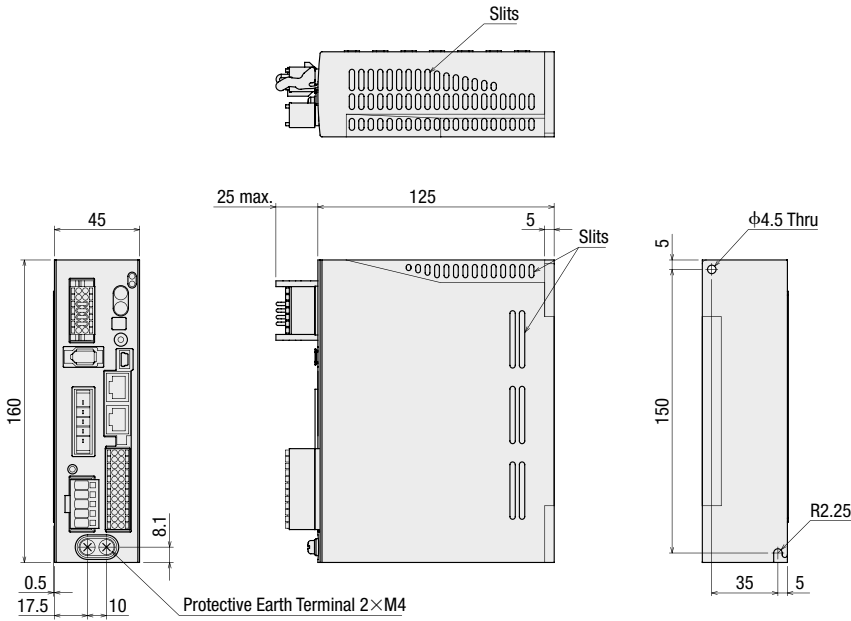

● Accessories

Connector for Main Power Supply/Regeneration Unit (CN4)

Connector: 05JFAT-SAXGDK-H5.0
(JST Mfg. Co., Ltd.)

Connector for Input/Output Signal (CN5)

Connector: DFMC1,5/12-ST-3,5
(PHOENIX CONTACT GmbH & Co. KG)

Connector for 24 VDC Power Supply Input/Regeneration Unit Thermal Input/Electromagnetic Brake Output Terminal (CN1)

Connector: DFMC1,5/7-ST-3,5-LR
(PHOENIX CONTACT GmbH & Co. KG)

Lever for Connector: J-FAT-0T

(JST Mfg. Co., Ltd.)

◇ Pulse-Input Type

Driver Product Name: **AZD-C**

Mass: 0.65 kg

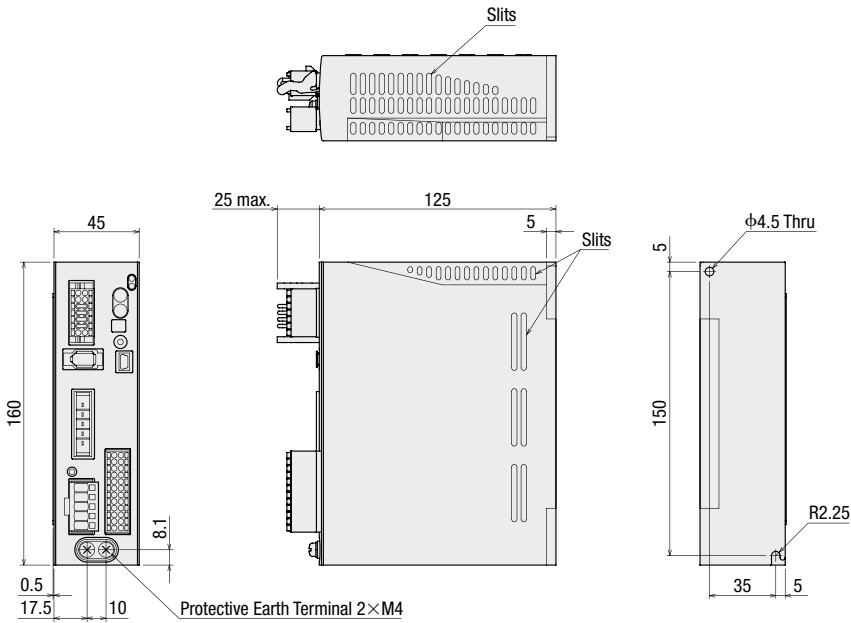

● Accessories

Connector for Main Power Supply/Regeneration Unit (CN4)

Connector: 05JFAT-SAXGDK-H5.0
(JST Mfg. Co., Ltd.)

Connector for Input/Output Signal (CN5)

Connector: DFMC1,5/12-ST-3,5
(PHOENIX CONTACT GmbH & Co. KG)

Connector for 24 VDC Power Supply Input/Regeneration Unit Thermal Input/Electromagnetic Brake Output Terminal (CN1)

Connector: DFMC1,5/7-ST-3,5-LR
(PHOENIX CONTACT GmbH & Co. KG)

Lever for Connector: J-FAT-0T

(JST Mfg. Co., Ltd.)

● Connection Cable Sets / Flexible Connection Cable Sets

◇ Connection Cable for Motor

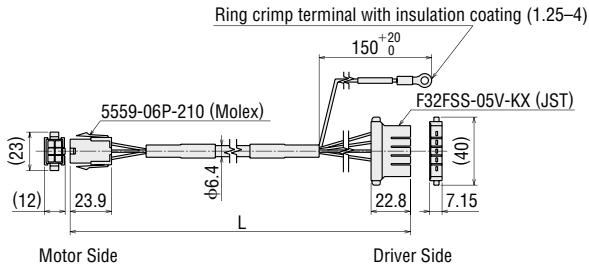

◇ Connection Cable for Electromagnetic Brake
(Only for electromagnetic brake products)

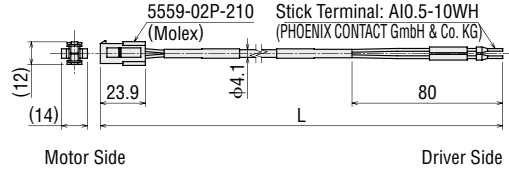

◇ Connection Cable for Encoder

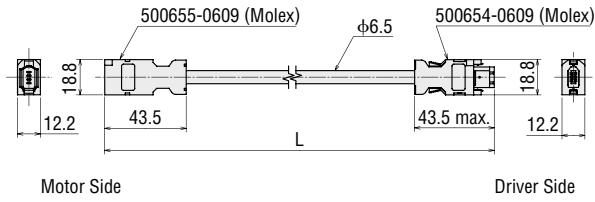

*The length L [m] is specified where L is located in the dimensions in "Product Line" on page 19.

Notes

- The motor cable and electromagnetic brake cable from the motor cannot be connected directly to the driver. When connecting to a driver, use the connection cable.

AC Input	Features
	System Configuration
	Product Line
	Specifications and Features
DC Input	Dimensions
	Connection and Operation
	System Configuration
	Product Line
	Specifications and Features
	Dimensions
	Connection and Operation
	Multiaxis Driver
Accessories	

Connection and Operation (Built-in Controller Type / Pulse-Input Type with RS-485 Communication)

Name and Functions of Driver Parts

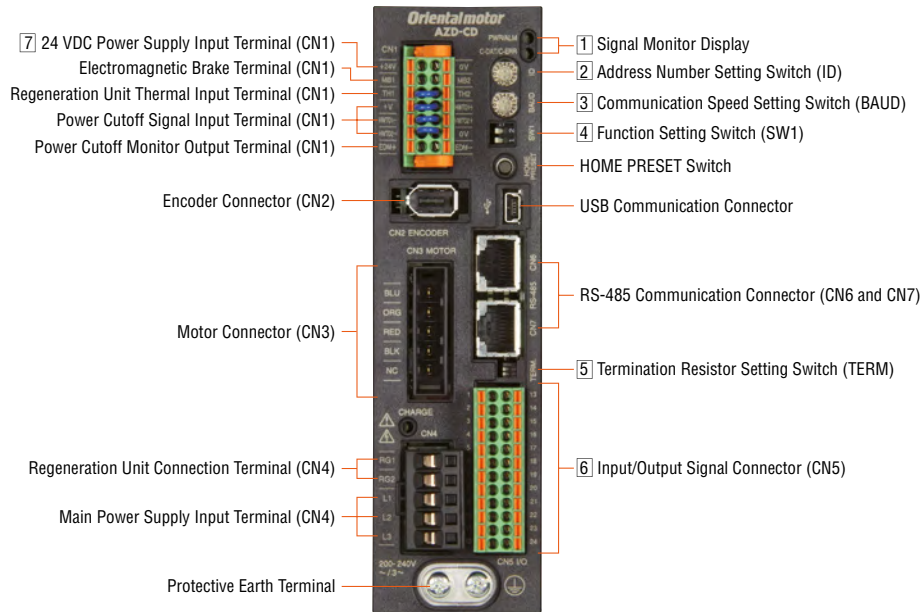

1 Signal Monitor Displays

◇ LED Displays

Display	Colour	Function	When Activated
PWR	Green	Power Display	When 24 VDC power is on.
ALM	Red	Alarm Display	Blinks when protective functions are activated.
C-DAT	Green	Communication Display	When communication data is received or sent.
C-ERR	Red	Communication Error Display	When there is an error with communication data.

2 Address Number Setting Switch (ID)

Display	Function
ID	Set the address number for RS-485 communication (Factory Setting: Built-in controller type : 0. Pulse input with RS-485 communication type : 1)

3 Communication Speed Setting Switch

Display	Function
BAUD	Set this when using RS-485 communication. Set the communication speed (Factory Setting: Built-in controller type : 7. Pulse input with RS-485 communication type : 4)

4 Function Setting Switch

Display	No.	Function
SW1	1	This sets the address number in combination with the address number setting switch (ID) (Factory Setting: OFF).
	2	Set the protocol of RS-485 communication (Factory Setting: Built-in controller type: OFF. Pulse input with RS-485 communication type : ON)

◇ Settings of the RS-485 Communication Speed

No.	Baud Rate [bps]
0	9600
1	19200
2	38400
3	57600
4	115200
5	230400
6	Not used
7	Network Converter
8-F	Not used

5 Termination Resistor Setting Switch

Display	No.	Function
TERM	1	Set the RS-485 communication termination resistor (120Ω) (Factory Setting: OFF) . OFF: no termination resistor, ON: termination resistor connected.
	2	

● Please use the same settings for both No. 1 and No. 2.

6 Input/Output Signal Connector (CN5)

For the Pulse-Input Type with RS-485 Communication pin No. 1, 2, 13 and 14 are for pulse input. For connecting to a programmable controller refer to page 63-64 of the Pulse-Input Type.

Display	Pin Number	Driver Type	Signal Name	Content
CN5	1	Built-In Controller Type	IN0	START This signal is used to start positioning operation.
		Pulse-Input Type with RS-485 Communication	CW+* [PLS+]	CW Pulse Input+ [Pulse Input+] Pulse signal for motor operation in CW direction with 2 pulse input method. The brackets [] show the content when using 1 pulse input method.
	2	Built-In Controller Type	IN2	M1 Use the 3 bits of M0, M1, M2, to select the drive data No.
		Pulse-Input Type with RS-485 Communication	CCW+* [DIR+]	CCW Pulse Input+ [Rotation Direction Input+] Pulse signal for motor operation in CCW direction with 2 pulse input method. The brackets [] show the content when using 1 pulse input method.
	3	Common	IN4	ZHOME Move to the home position set with the HOME PRESET switch.
	4	Common	IN6	STOP Stop the motor.
	5	Common	IN-COM [0-7]*	IN0-IN7 input common
	6	Common	IN8	FW-JOG Start JOG operation.
	7	Common	OUT0	HOME-END Output when determining the home position or completing high speed return-to-home operation.
	8	Common	OUT2	PLS-RDY Not used
	9	Common	OUT4	MOVE Output while operating the motor.
	10	Common	OUT-COM*	Output common
	11	Common	ASG+	A phase pulse output+
	12	Common	BSG+	B phase pulse output+
	13	Built-In Controller Type	IN1	M0 Use the 3 bits of M0, M1, M2, to select the drive data No.
		Pulse-Input Type with RS-485 Communication	CW-* [PLS-]	CW-* [PLS-] Pulse signal for motor operation in CW direction with 2 pulse input method. The brackets [] show the content when using 1 pulse input method.
	14	Built-In Controller Type	IN3	M2 Use the 3 bits of M0, M1, M2, to select the drive data No.
		Pulse-Input Type with RS-485 Communication	CCW-* [DIR-]	CCW Pulse Input+ [Rotation Direction Input+] Pulse signal for motor operation in CCW direction with 2 pulse input method. The brackets [] show the content when using 1 pulse input method.
	15	Common	IN5	FREE The motor is set to non-excitation.
	16	Common	IN7	ALM-RST Reset the alarm.
	17	Common	IN-COM [8-9]*	IN8, IN9 input common
	18	Common	IN9	RV-JOG Start JOG operation.
	19	Common	OUT1	IN-POS Output when the motor operation is complete.
	20	Common	OUT3	READY Output when the driver is ready for operation.
21	Common	OUT5	ALM-B Output the driver alarm state (normal close).	
22	Common	GND* ¹⁾	Ground	
23	Common	ASG-	A phase pulse output -	
24	Common	BSG-	B phase pulse output -	

● Assigned functions are set by means of the parameter settings. The above is the initial value. For details, refer to the User's Manual.

* The initial value setting cannot be changed.

7 24 VDC Input/Electromagnetic Brake Connection Terminal/Regeneration Unit Thermal Input/Power Cutoff Signal Input Terminal/Power Cutoff Monitor Output Terminal (CN1)

Display	Input/Output	Terminal Name	Content
+24 V	Input	24 VDC Power Input Terminal+	This is the driver control circuit power. Be sure to connect this.
0 V		24 VDC Power Input Terminal-	
MB1	Output	Electromagnetic Brake Connection Terminal-	Connect the cable for Electromagnetic Brake Connection Terminal.
MB2		Electromagnetic Brake Connection Terminal+	
TH1	Input	Regeneration Unit Thermal Input Terminal	Connect the optional regenerative resistance (RGB100) (sold separately). When not connecting the regenerative resistance, short circuit between the terminals (RGB100).
TH2		Regeneration Unit Thermal Input Terminal	
HWT01+	Input	Drive Cutoff Signal Input Terminal 1+	Connect the switch and programmable controller. When either HWT01 input or HWT02 input is OFF, the electricity to the motor is cut directly by hardware without the CPU.
HWT01-		Drive Cutoff Signal Input Terminal 1-	
HWT02+		Drive Cutoff Signal Input Terminal 2+	
HWT02-		Drive Cutoff Signal Input Terminal 2-	
EDM+	Output	Drive Cutoff Signal Input Terminal+	Connect the programmable controller. When both HWT01 input and HWT02 input are OFF, EDM output becomes ON.
EDM-		Drive Cutoff Signal Input Terminal-	

● Connection Diagram

◇ Connection to Peripheral Equipment

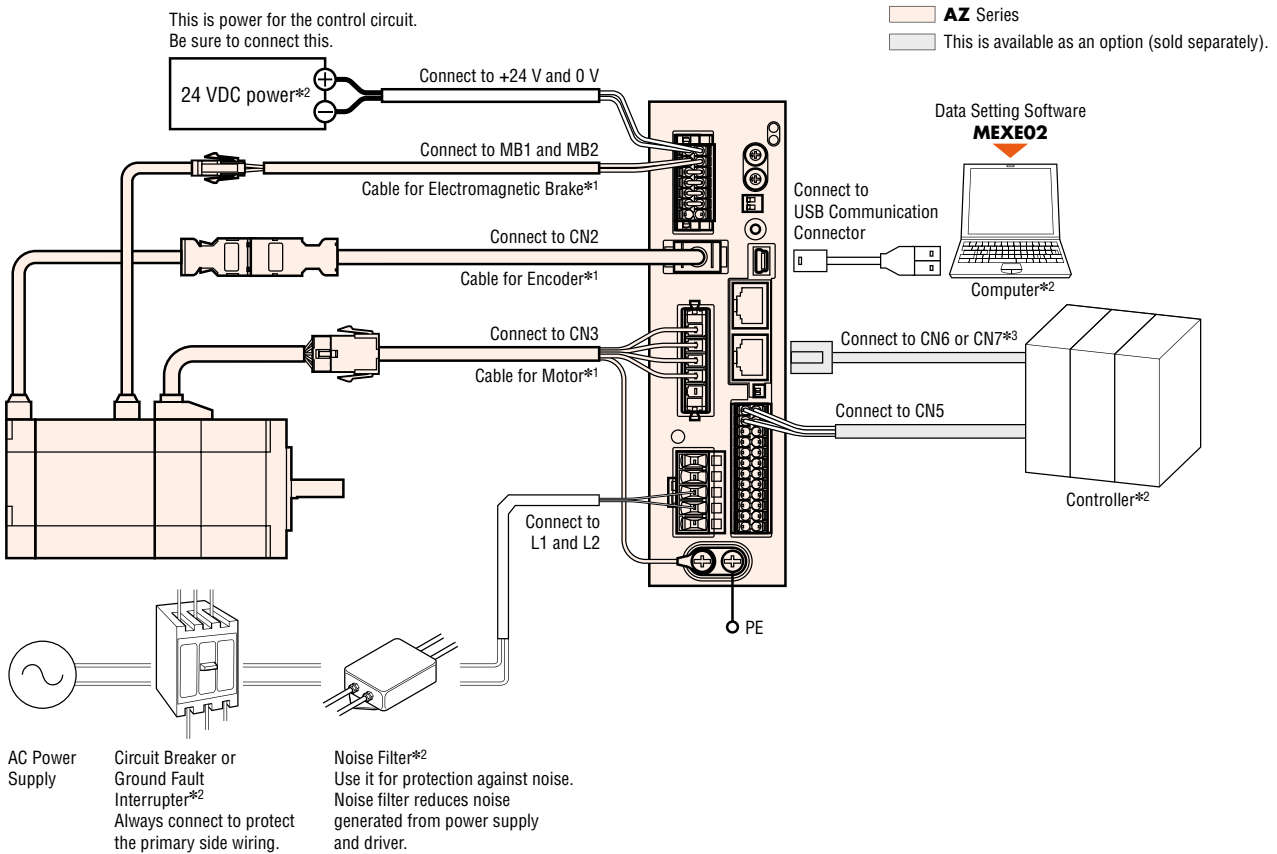

*1 Make sure a cabling distance between the motor and the driver is 20 m or less.

*2 Prepared by the customer.

*3 When controlling with RS-485 communications, connect to the controller.

◇ Connecting a Main Power Supply

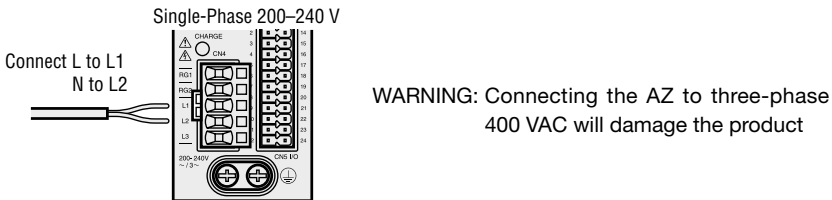

◇ USB Cable Connection

The computer on which the data setting software **MEXE02** is installed and driver are connected with a USB cable. Use the following specifications for the USB cable.

Specification	USB 2.0 (full speed)
Cable	Length: 3 m (or less)
	Format: A-mini-B

◇ Connecting to a Host Controller

● Connecting to a Current Sink Output Circuit

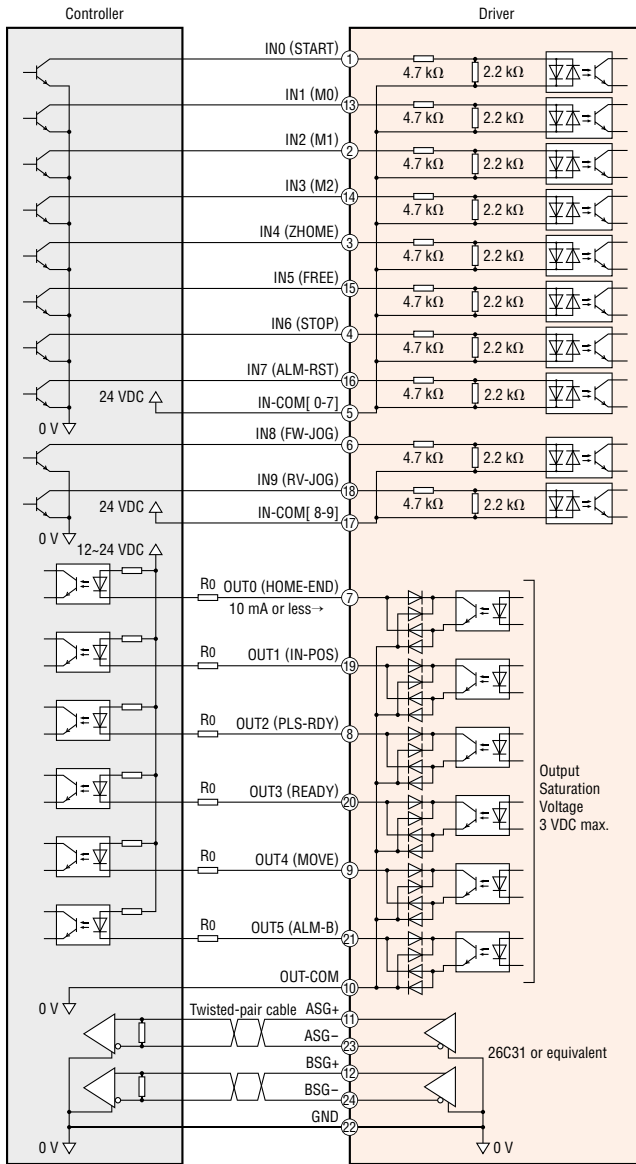

Notes

- Use 24 VDC for the input signals.
- Use output signal at 12~24 VDC 10 mA or less. When the current value exceeds 10 mA, connect an external resistor R_o to reduce the current to 10 mA or less.
- Make sure the signal line is wired at a distance of 200 mm or longer from the power lines (power supply line and motor line). Further, do not insert the signal line in the same pipe as the power lines or bundle them together.
- When noise is emitted from the motor cable or power cable due to wiring or allocation and it cause a problem, shield the cable or use ferrite cores.

● Connecting to a Current Source Output Circuit

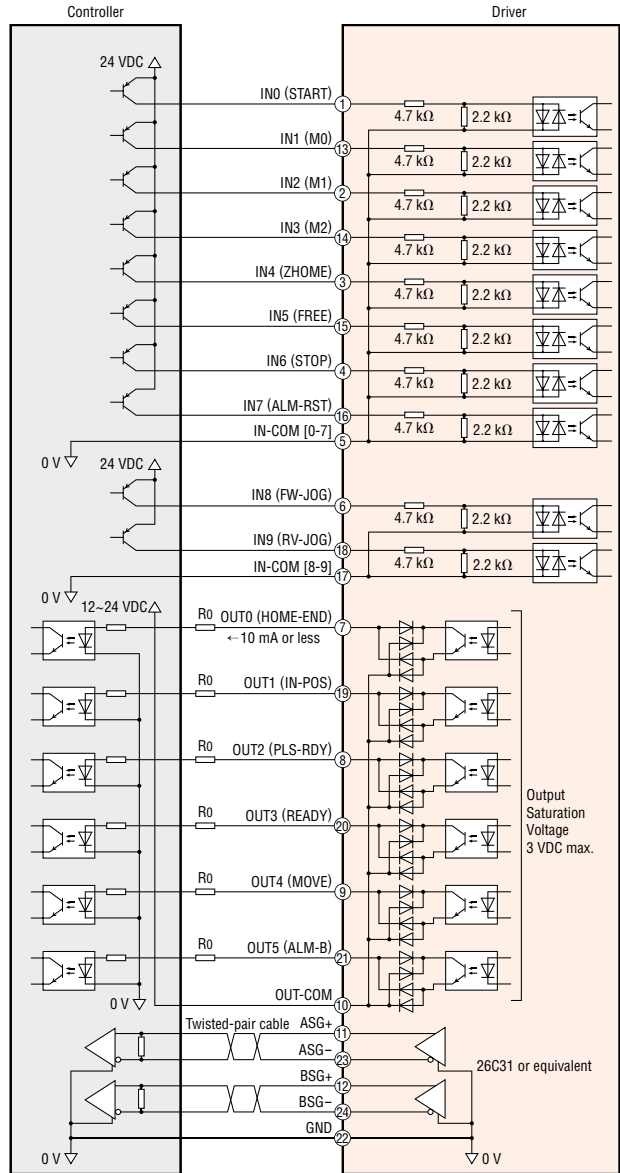

Notes

- Use 24 VDC for the input signals.
- Use output signal at 12~24 VDC 10 mA or less. When the current value exceeds 10 mA, connect an external resistor R_o to reduce the current to 10 mA or less.
- Make sure the signal line is wired at a distance of 200 mm or longer from the power line (power supply line and motor line). Further, do not insert the signal line in the same pipe as the power lines or bundle them together.
- When noise is emitted from the motor cable or power cable due to wiring or allocation and it cause a problem, shield the cable or use ferrite cores.

◇ Connecting to a Programmable Controller (Pulse-Input Type with RS-485 Communication)

The connection diagram is the same like that of the Pulse-Input Type. See page 63-64

Features
System Configuration
Product Line
Specifications and Features
AC Input
Dimensions
Connection and Operation
System Configuration
Product Line
Specifications and Features
DC Input
Dimensions
Connection and Operation
Multiaxis Driver
Accessories

Connection and Operation (Pulse-Input Type)

Names and Functions of Driver Parts

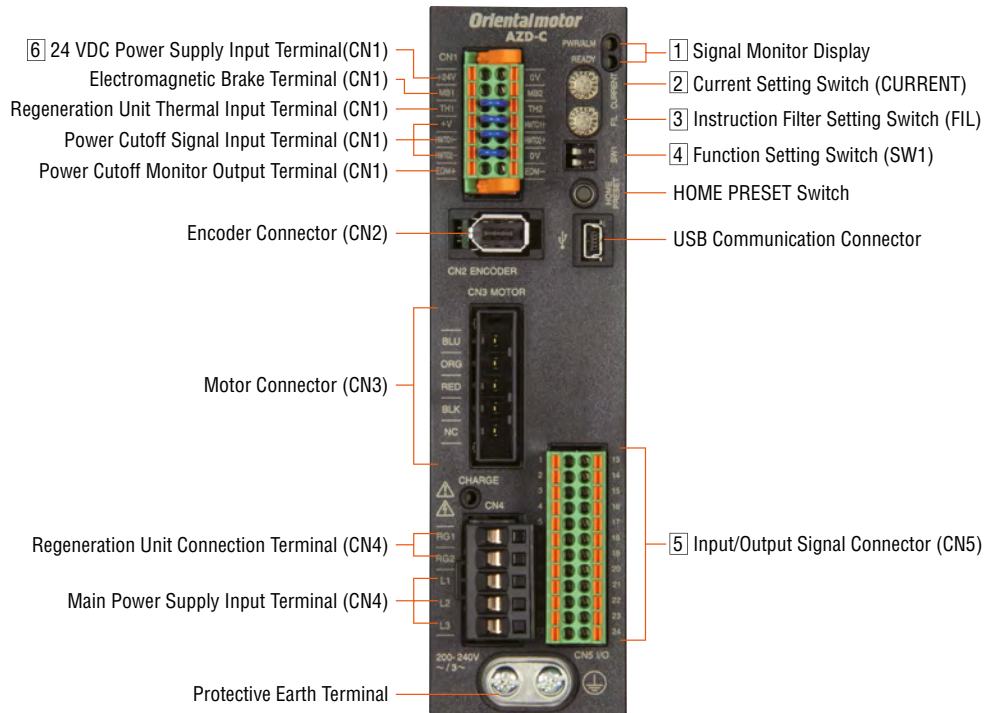

1 Signal Monitor Displays

◇ LED Display

Display	Colour	Function	When Activated
PWR	Green	Power Display	When 24 VDC power is on.
ALM	Red	Alarm Display	Blinks when protective functions are activated.
READY	Green	READY Output	When READY output is set to ON.

2 Current Setting Switch

Display	Function
CURRENT	Set basic current that is the base for the operation current and stop current (Factory Setting: F).

3 Command Filter Setting Switch

Display	Function
FIL	Adjust the responsiveness of the motor (Factory Setting: 1).

4 Function Setting Switch

Display	No.	Function
SW1	1	Sets the resolution per one rotation of the motor output shaft: OFF [1000 p/r] (Factory Setting); ON [10000 p/r]
	2	Sets the pulse input format to 1 pulse input mode or 2 pulse input mode. (Factory setting: ON [1-pulse input mode])

5 Input/Output Signal Connector (CN4)

Display	Pin Number	Signal Name	Content	
CN4	1	CW+[PLS+]*1	CW pulse input+[pulse input+]	Pulse signal for motor operation in CW direction with 2 pulse input method. The brackets [] show the content when using 1 pulse input method.
	2	CCW+[DIR+]*1	CCW pulse input+[rotation direction input+]	Pulse signal for motor operation in CCW direction with 2 pulse input method. The brackets [] show the content when using 1 pulse input method.
	3	IN4	ZHOME	Move to the home position set with the HOME PRESET switch.
	4	IN6	STOP	Stop the motor.
	5	IN-COM [4-7]*1	IN4-IN7 input common	
	6	IN8	FW-JOG	Start JOG operation.
	7	OUT0	HOME-END	Output when determining the home position or completing high speed return-to-home operation.
	8	OUT2	PLS-RDY	Output when the pulse input preparation is complete.
	9	OUT4	MOVE	Output while operating the motor.
	10	OUT-COM*1	Output common	
	11	ASG+	A phase pulse output+	
	12	BSG+	B phase pulse output+	
	13	CW-[PLS-]*1	CW pulse input-[pulse input-]	Pulse signal for motor operation in CW direction with 2 pulse input method. The brackets [] show the content when using 1 pulse input method.
	14	CCW-[DIR-]*1	CCW pulse input-[rotation direction input -]	Pulse signal for motor operation in CCW direction with 2 pulse input method. The brackets [] show the content when using 1 pulse input method.
	15	IN5	FREE	The motor is set to non-excitation.
	16	IN7	ALM-RST	Reset the alarm.
	17	IN-COM [8-9]*1	IN8, IN9 input common	
	18	IN9	RV-JOG	Start JOG operation.
	19	OUT1	IN-POS	Output when the motor operation is complete.
	20	OUT3	READY	Outputs when the driver is ready for operation.
	21	OUT5	ALM-B	Output the driver alarm state (normal close).
	22	GND*1	Ground	
	23	ASG-	A phase pulse output-	
	24	BSG-	B phase pulse output-	

● Assigned functions are set by means of the parameter settings. The above is the initial value. For details, refer to the User's Manual.

*1 The initial value setting cannot be changed.

6 24 VDC Assigned functions are set by means of the parameter settings. The above is the initial value. For details, refer to the User's Manual. (CN1)

Display	Input/Output	Terminal Name	Content
+24 V	Input	24 VDC Power Input Terminal +	This is the driver control circuit power. Be sure to connect this.
0 V		24 VDC Power Input Terminal -	
MB1	Output	Electromagnetic Brake Terminal -	Connect the cable for electromagnetic brake of the electromagnetic brake type motor.
MB2		Electromagnetic Brake Terminal +	
TH1	Input	Regeneration Unit Thermal Input Terminal	Connect the optional regenerative resistance (RGB100) (sold separately). When not connecting the regenerative resistance, short circuit between the terminals (RGB100).
TH2		Regeneration Unit Thermal Input Terminal	
HWT01 +	Input	Drive Cutoff Signal Input Terminal 1 +	Connect the switch and programmable controller. When either HWT01 input or HWT02 input is OFF, the electricity to the motor is cut directly by hardware without the CPU.
HWT01 -		Drive Cutoff Signal Input Terminal 1 -	
HWT02 +		Drive Cutoff Signal Input Terminal 2 +	
HWT02 -		Drive Cutoff Signal Input Terminal 2 -	
EDM +	Output	Drive Cutoff Monitor Output Terminal +	Connect the programmable controller. When both HWT01 input and HWT02 input are OFF, EDM output becomes ON.
EDM -		Drive Cutoff Monitor Output Terminal -	

● **Connection Diagram**

◇ **Connection to Peripheral Equipment**

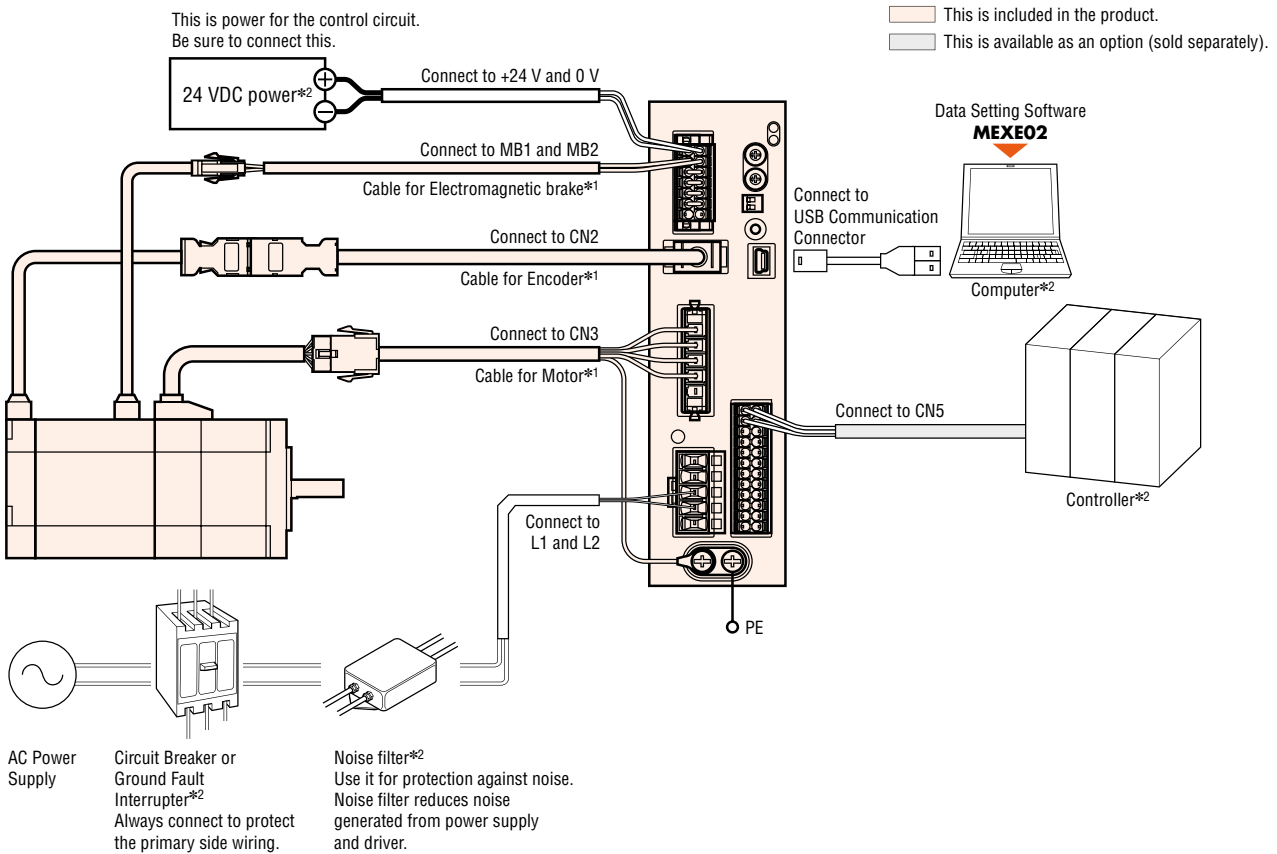

*1 Make sure a cabling distance between the motor and the driver is 20 m or less.

*2 Prepared by the customer.

◇ **Connecting a Main Power Supply**

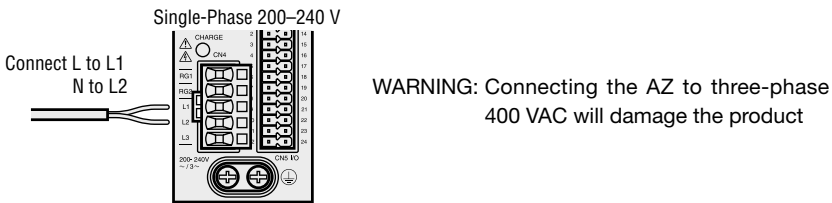

◇ **USB Cable Connection**

The computer on which the data setting software **MEXE02** is installed and driver are connected with a USB cable. Use the following specifications for the USB cable.

Specification	USB 2.0 (full speed)
Cable	Length: 3 m (or less)
	Format: A-mini-B

◇ Connecting to a Host Controller

● Connecting to a Current Sink Output Circuit

When the pulse input is a line driver

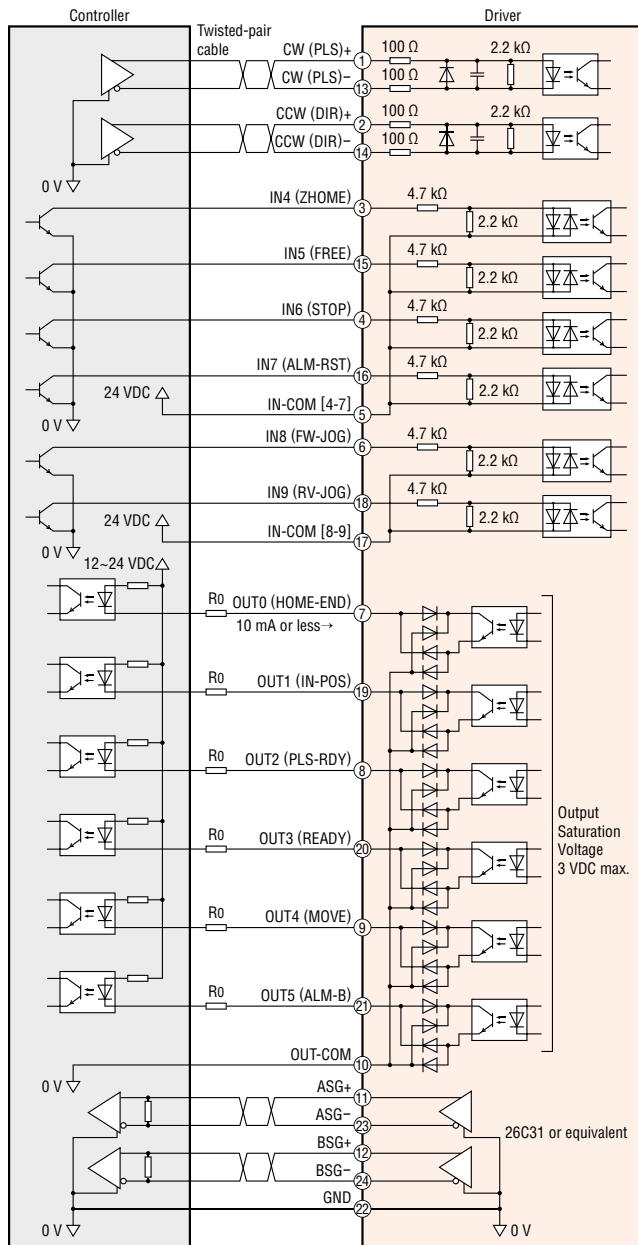

Notes

- Use 24 VDC for the input signals.
- Use output signal at 12~24 VDC 10 mA or less. When the current value exceeds 10 mA, connect the external resistance R₀ to reduce the current to 10 mA or less.
- Make sure the signal line is wired at a distance of 200 mm or longer from the power line (power supply line and motor line). Furthermore, do not insert the signal line in the same pipe as the power lines or bundle them together.
- When noise is emitted from the motor cable or power cable due to wiring or allocation and it cause a problem, shield the cable or use ferrite cores.

When the pulse input is an open collector

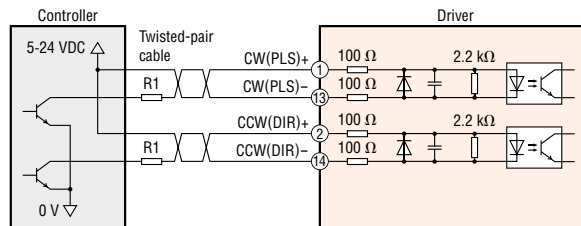

Notes

- For CW (PLS) input and CCW (DIR) input, use 5~24 VDC. Where the voltage exceeds 5 VDC, connect the external resistance R₁ to adjust the input current to be 7~20 mA.

Features
System Configuration
Product Line
Specifications and Features
AC Input
Dimensions
Connection and Operation
System Configuration
Product Line
Specifications and Features
DC Input
Dimensions
Connection and Operation
Multiaxis Driver
Accessories

◇ Connecting to a Host Controller

● Connecting to a Current Source Output Circuit

When the pulse input is a line driver

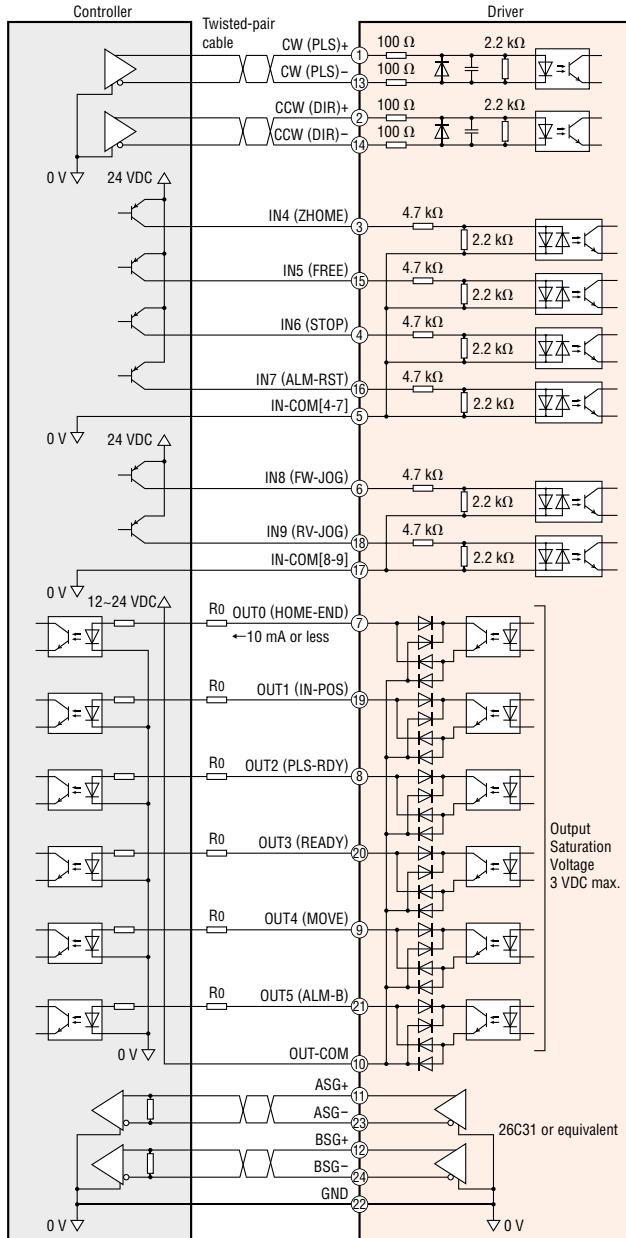

Notes

- Use 24 VDC for the input signals.
- Use output signal at 12~24 VDC 10 mA or less. When the current value exceeds 10 mA, connect to external resistance R_0 to reduce the current to 10 mA or less.
- Make sure the signal line is wired at a distance of 200 mm or longer from the power line (power supply line and motor line). Furthermore, do not insert the signal line in the same pipe as the power lines or bundle them together.
- When noise is emitted from the motor cable or power cable due to wiring or allocation and it cause a problem, shield the cable or use ferrite cores.

When the pulse input is an open collector

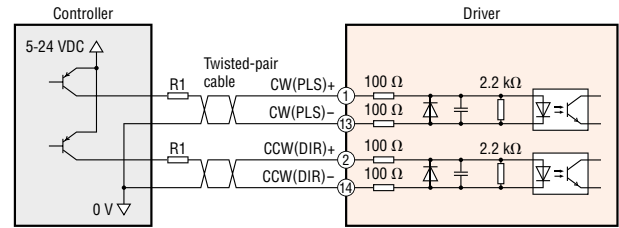

Notes

- For CW (PLS) input and CCW (DIR) input, use 5~24 VDC. Where the voltage exceeds 5 VDC, connect the external resistance R_1 to adjust the input current to be 7~20 mA.

System Configuration

Combination of Standard Type Motor with Electromagnetic Brake and Built-in Controller Type Driver or Pulse-Input Type Driver with RS-485 Communication

An example of a configuration using I/O control or RS-485 communication is shown below.
Motors, drivers, and cables must be ordered individually.

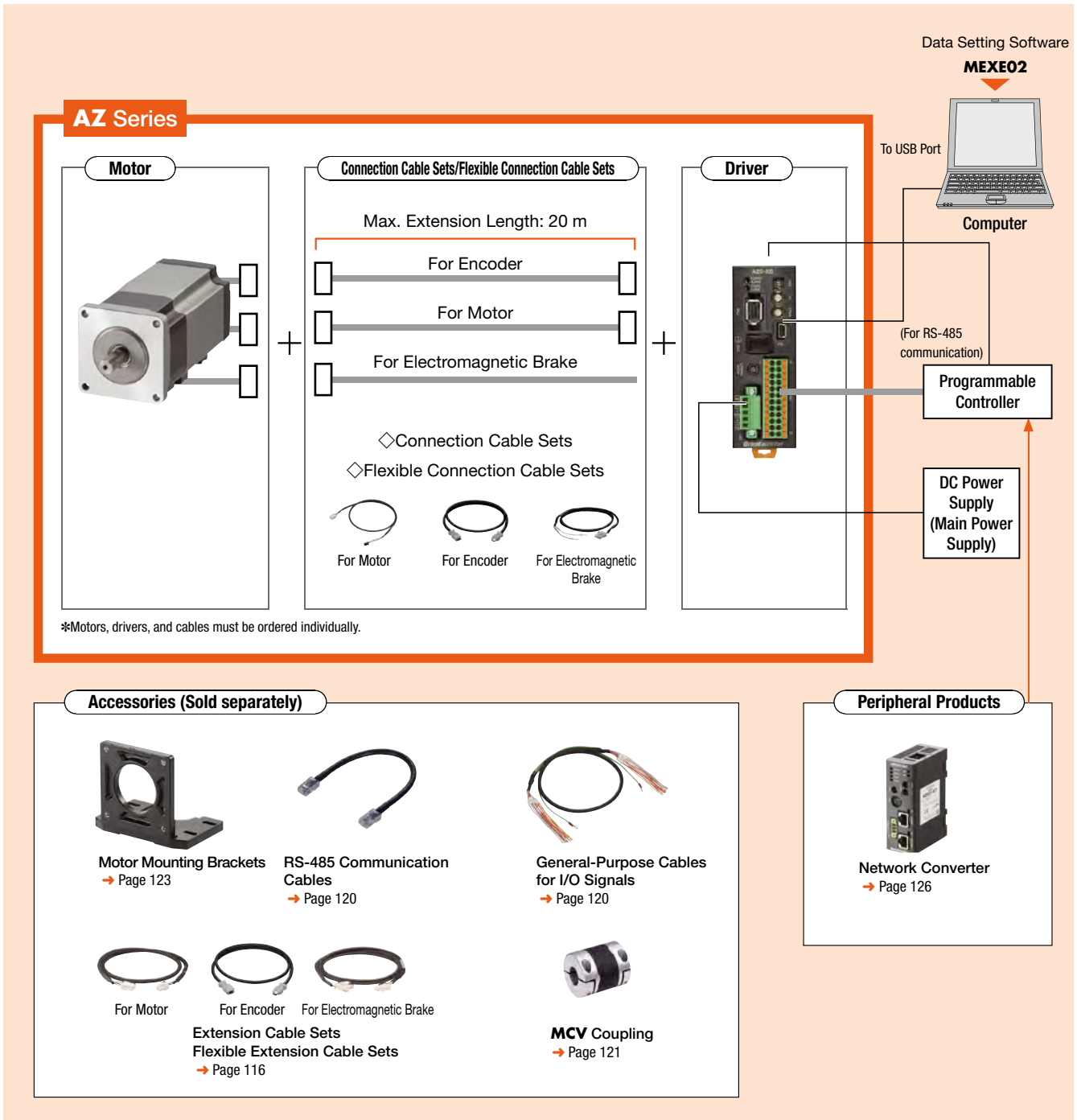

System Configuration Example

AZ Series			Accessory		
Motor	Driver	Connection Cable Sets	Sold Separately		
AZM66MK	AZD-KD	CC030VZFB2	Motor Mounting Bracket	Flexible Coupling	General-Purpose Cables for I/O Signals (1 m)
492.00 €	396.00 €	69.00 €	PAL2P-5	MCV251010	CC16D010B-1
			13.00 €	53.00 €	20.00 €

● The system configuration shown above is an example. Other combinations are also available.

Note

● The motor cable and electromagnetic brake cable from the motor cannot be connected directly to the driver. When connecting to a driver, use a connection cable.

● **Combination of Standard Type Motor with Electromagnetic Brake and Pulse Input Type Driver or Pulse-Input Type Driver with RS-485 Communication**

An example of a single-axis system configuration with the **SCX11** controller is shown below. Motors, drivers, and cables must be ordered individually.

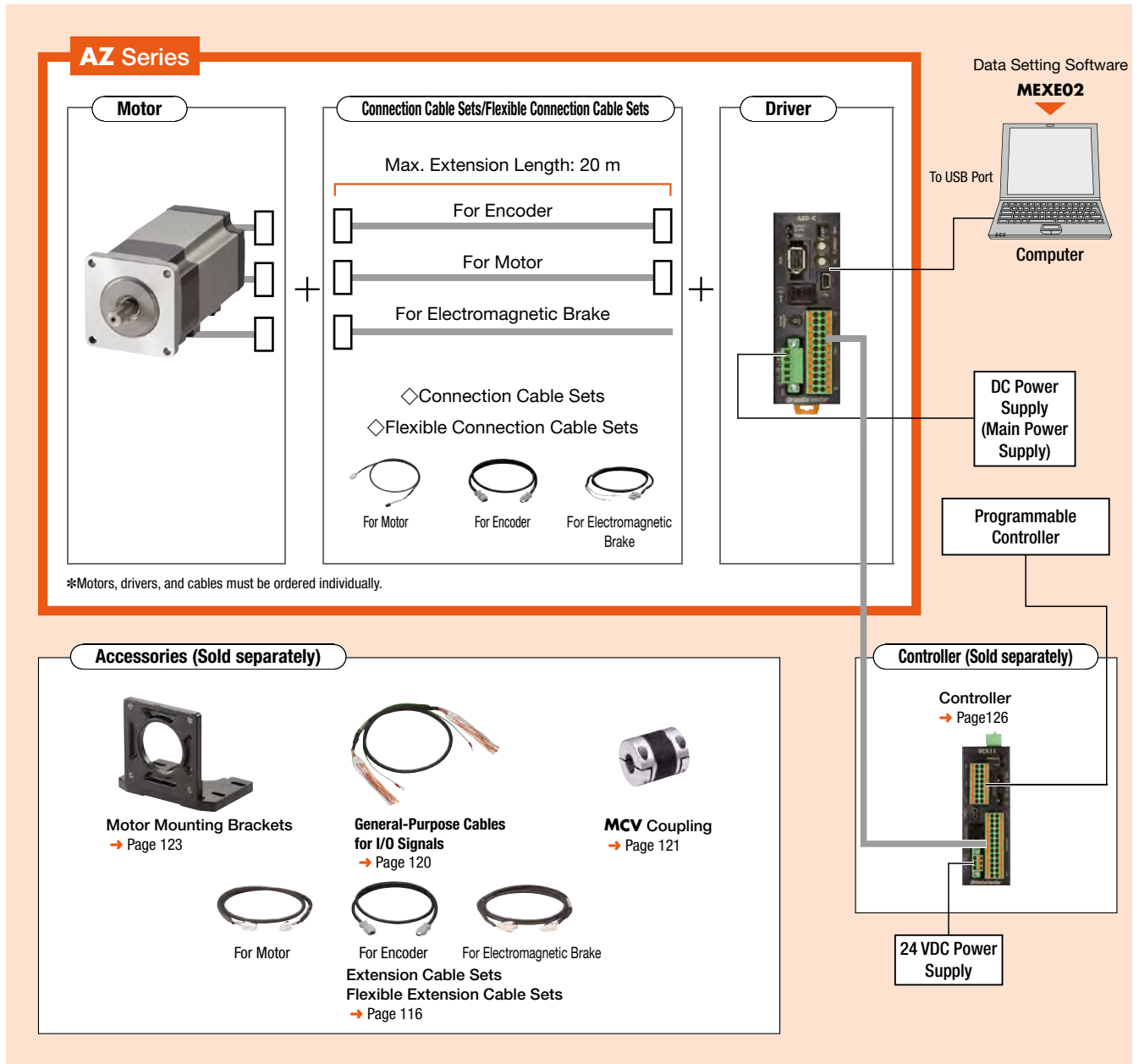

● **System Configuration Example**

AZ Series			Accessory			
Motor	Driver	Connection Cable Sets	Sold Separately			
AZM66MK	AZD-K	CC030VZFB2	Controller	Motor Mounting Brackets	Flexible Coupling	General-Purpose Cables for I/O Signals (1 m)
492.00 €	341.00 €	69.00 €	SCX11	PAL2P-5	MCV251010	CC16D010B-1
			237.00 €	13.00 €	53.00 €	20.00 €

● The system configuration shown above is an example. Other combinations are also available.

Note

● The motor cable and electromagnetic brake cable from the motor cannot be connected directly to the driver. When connecting to a driver, use a connection cable.

Product Number Code

Motor

◇ Standard Type

AZM 6 6 A 0 K

① ② ③ ④ ⑤ ⑥

◇ PS, HPG, Harmonic Geared Type

AZM 6 6 A K - HP 15 F

① ② ③ ④ ⑤ ⑥ ⑦ ⑧ ⑨

◇ TS Geared Type

AZM 6 6 A K - TS 10 U

① ② ③ ④ ⑤ ⑥ ⑦ ⑧

◇ FC Geared Type

AZM 6 6 A K - FC 10 U A

① ② ③ ④ ⑤ ⑥ ⑦ ⑧ ⑨

Driver

AZD - K D

① ② ③

Connection Cable Sets/Flexible Connection Cable Sets

CC 050 V Z □ F B 2

① ② ③ ④ ⑤ ⑥ ⑦ ⑧

①	Motor Type	AZM: AZ Series Motor
②	Motor Frame Size	1: 20 mm 2: 28 mm 4: 42 mm (HPG Geared Type is 40 mm) 6: 60 mm
③	Motor Case Length	
④	Configuration	A: Single Shaft M: With Electromagnetic Brake
⑤	Shaft Shape	0: Straight Type 1: With Key
⑥	Motor Specification	K: DC Power Supply Input
⑦	Geared Type	TS: TS Geared Type PS: PS Geared Type HP: HPG Geared Type HS: Harmonic Geared Type
⑧	Gear Ratio	
⑨	Output Shaft Type	HPG Geared Type Blank: Shaft Output F: Flange Output

*For standard types without specified shaft shape one shaft side is milled.

①	Motor Type	AZM: AZ Series Motor
②	Motor Frame Size	4: 42 mm 6: 60 mm
③	Motor Case Length	
④	Configuration	A: Single Shaft M: With Electromagnetic Brake
⑤	Motor Specification	K: DC Power Supply Input
⑥	Geared Type	TS: TS Geared Type
⑦	Gear Ratio	
⑧	Cable Direction	U: Up L: Left R: Right

①	Motor Type	AZM: AZ Series Motor
②	Motor Frame Size	4: 42 mm 6: 60 mm
③	Motor Case Length	
④	Configuration	A: Single Shaft M: With Electromagnetic Brake
⑤	Motor Specification	K: DC Power Supply Input
⑥	Geared Type	FC: FC Geared Type
⑦	Gear Ratio	
⑧	Cable Direction	D: Down U: Up
⑨	Identification	A: Solid shaft

*With the output shaft pointing to the left the cable direction is defined by looking from the gearhead side.

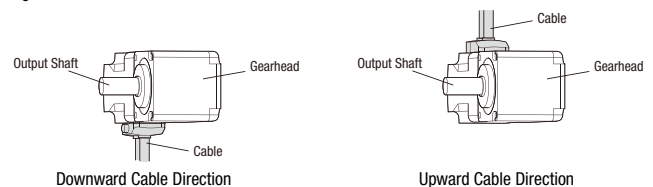

①	Driver Type	AZD: AZ Series Driver
②	Power Supply Input	K: 24/48 VDC
③	Type	D: Built-in Controller Type X: Pulse-Input Type with RS-485 Communication Blank: Pulse Input Type

①		CC: Cable
②	Length	005: 0.5 m 010: 1 m 015: 1.5 m 020: 2 m 025: 2.5 m 030: 3 m 040: 4 m 050: 5 m 070: 7 m 100: 10 m 150: 15 m 200: 20 m
③	Reference Number	
④	Applicable Models	Z: AZ Series
⑤	Reference Number	Blank: Frame Size 42 mm (HPG Geared Type is 40 mm), 60 mm 2: Frame Size 20 mm, 28 mm
⑥	Cable Type	F: Connection Cable Sets R: Flexible Connection Cable Sets
⑦	Electromagnetic Brake	Blank: Without Electromagnetic Brake B: With Electromagnetic Brake
⑧	Cable Specifications	2: DC Power Supply Input

Features

System Configuration

Product Line

AC Input

Specifications and Features

Dimensions and Operation

System Configuration

Product Line

Specifications and Features

DC Input

Dimensions and Operation

Connection and Operation

Multiaxis Driver

Accessories

Product Line

Motor

◇ Standard Type



Frame Size [mm]	Product Name	List Price
20	AZM14AK	253.00 €
	AZM15AK	
28	AZM24AK	253.00 €
	AZM26AK	
	AZM28AK	
42	AZM46AK	271.00 €
	AZM46A0K	
	AZM48AK	281.00 €
	AZM48A0K	
	AZM48A1K	292.00€
	60	AZM66AK
AZM66A0K		
AZM66A1K		319.00 €
AZM69AK		325.00 €
AZM69A0K		
AZM69A1K	335.00 €	

◇ Standard Type with Electromagnetic Brake



Frame Size [mm]	Product Name	List Price
42	AZM46MK	405.00 €
	AZM46M0K	
60	AZM66MK	492.00 €
	AZM66M0K	
	AZM66M1K	492.00 €
	AZM69MK	498.00 €
	AZM69M0K	
AZM69M1K	506.00 €	

◇ TS Geared Type



Frame Size [mm]	Product Name	Gear Ratio	List Price
42	AZM46AK-TS□UA	3.6, 7.2	376.00 €
	AZM46AK-TS□UA	10, 20, 30	387.00 €
60	AZM66AK-TS□UA	3.6, 7.2	440.00 €
	AZM66AK-TS□UA	10, 20, 30	451.00 €

◇ TS Geared Type with Electromagnetic Brake



Frame Size [mm]	Product Name	Gear Ratio	List Price
42	AZM46MK-TS□UA	3.6, 7.2	510.00 €
	AZM46MK-TS□UA	10, 20, 30	521.00 €
60	AZM66MK-TS□UA	3.6, 7.2	613.00 €
	AZM66MK-TS□UA	10, 20, 30	624.00 €

◇ FC Geared Type



Frame Size [mm]	Product Name	Gear Ratio	List Price
42	AZM46AK-FC□UA	7.2, 10, 20, 30	497.00 €
	AZM46AK-FC□DA		
60	AZM66AK-FC□UA	7.2, 10, 20, 30	561.00 €
	AZM66AK-FC□DA		

◇ FC Geared Type with Electromagnetic Brake



Frame Size [mm]	Product Name	Gear Ratio	List Price
42	AZM46MK-FC□UA	7.2, 10, 20, 30	631.00 €
	AZM46MK-FC□DA		
60	AZM66MK-FC□UA	7.2, 10, 20, 30	734.00 €
	AZM66MK-FC□DA		

◇ PS Geared Type



Frame Size [mm]	Product Name	Gear Ratio	List Price
42	AZM46AK-PS□	5, 7.2, 10	455.00 €
	AZM46AK-PS□	25, 36, 50	495.00 €
60	AZM66AK-PS□	5, 7.2, 10	544.00 €
	AZM66AK-PS□	25, 36, 50	601.00 €

◇ PS Geared Type with Electromagnetic Brake



Frame Size [mm]	Product Name	Gear Ratio	List Price
42	AZM46MK-PS□	5, 7.2, 10	589.00 €
	AZM46MK-PS□	25, 36, 50	630.00 €
60	AZM66MK-PS□	5, 7.2, 10	717.00 €
	AZM66MK-PS□	25, 36, 50	774.00 €

● A number indicating the gear ratio is entered where the box □ is located in the product name.
 ● Either **R** (right), **L** (left) or **U** (up) is entered for the cable withdrawing direction in ◇ in the product name.



◇ HPG Geared Type

Frame Size [mm]	Product Name	List Price
40	AZM46AK-HP5	605.00 €
	AZM46AK-HP5F	594.00 €
	AZM46AK-HP9	605.00 €
	AZM46AK-HP9F	594.00 €
60	AZM66AK-HP5	817.00 €
	AZM66AK-HP5F	800.00 €
	AZM66AK-HP15	961.00 €
	AZM66AK-HP15F	943.00 €

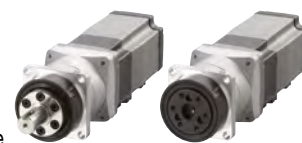

◇ HPG Geared Type with Electromagnetic Brake

Frame Size [mm]	Product Name	List Price
40	AZM46MK-HP5	746.00 €
	AZM46MK-HP5F	734.00 €
	AZM46MK-HP9	746.00 €
	AZM46MK-HP9F	734.00 €
60	AZM66MK-HP5	998.00 €
	AZM66MK-HP5F	980.00 €
	AZM66MK-HP15	1,141.00 €
	AZM66MK-HP15F	1,124.00 €



◇ Harmonic Geared Type

Frame Size [mm]	Product Name	Gear Ratio	List Price
42	AZM46AK-HS □	50, 100	772.00 €
60	AZM66AK-HS □		1,040.00 €



◇ Harmonic Geared Type with Electromagnetic Brake

Frame Size [mm]	Product Name	Gear Ratio	List Price
42	AZM46MK-HS □	50, 100	906.00 €
60	AZM66MK-HS □		1,213.00 €



● Driver

◇ Built-in Controller Type

Power Supply Input	Product Name	List Price
24/48 VDC	AZD-KD	396.00 €



◇ Pulse-Input Type with RS-485 Communication

Power Supply Input	Product Name	List Price
24/48 VDC	AZD-KX	396.00 €



◇ Pulse Input Type

Power supply input	Product Name	List Price
24/48 VDC	AZD-K	341.00 €

● Connection Cable Sets/Flexible Connection Cable Sets

Use the flexible connection cable in applications where the cable is bent and flexed repeatedly. To extend the connection cables extension cables and flexible extension cables are provided. Please see page 116-117.

The motor cable and electromagnetic brake cable from the motor cannot be connected directly to the driver. Use a connection cable to connect the driver.

[For **AZM14, AZM15, AZM24, AZM26**]



◇ Without Electromagnetic Brake

Product Line	Length L [m]	Product Name	List Price
Connection Cable Sets	0.5	CC005VZ2F2	32.00 €
	1	CC010VZ2F2	32.00 €
	1.5	CC015VZ2F2	36.00 €
	2	CC020VZ2F2	42.00 €
	2.5	CC025VZ2F2	47.00 €
	3	CC030VZ2F2	53.00 €
	4	CC040VZ2F2	82.00 €
	5	CC050VZ2F2	92.00 €
	7	CC070VZ2F2	114.00 €
	10	CC100VZ2F2	149.00 €
	15	CC150VZ2F2	206.00 €
	20	CC200VZ2F2	261.00 €

Product Line	Length L [m]	Product Name	List Price
Flexible Connection Cable Sets	0.5	CC005VZ2R2	72.00 €
	1	CC010VZ2R2	72.00 €
	1.5	CC015VZ2R2	77.00 €
	2	CC020VZ2R2	83.00 €
	2.5	CC025VZ2R2	89.00 €
	3	CC030VZ2R2	77.00 €
	4	CC040VZ2R2	107.00 €
	5	CC050VZ2R2	119.00 €
	7	CC070VZ2R2	152.00 €
	10	CC100VZ2R2	200.00 €
	15	CC150VZ2R2	280.00 €
	20	CC200VZ2R2	359.00 €

[For **AZM46, AZM66, AZM69**]



◇ Without Electromagnetic Brake

Product Line	Length L [m]	Product Name	List Price
Connection Cable Sets	0.5	CC005VZF2	32.00 €
	1	CC010VZF2	32.00 €
	1.5	CC015VZF2	36.00 €
	2	CC020VZF2	42.00 €
	2.5	CC025VZF2	47.00 €
	3	CC030VZF2	53.00 €
	4	CC040VZF2	82.00 €
	5	CC050VZF2	92.00 €
	7	CC070VZF2	114.00 €
	10	CC100VZF2	149.00 €
	15	CC150VZF2	206.00 €
	20	CC200VZF2	261.00 €
Flexible Connection Cable Sets	0.5	CC005VZR2	72.00 €
	1	CC010VZR2	72.00 €
	1.5	CC015VZR2	77.00 €
	2	CC020VZR2	83.00 €
	2.5	CC025VZR2	88.00 €
	3	CC030VZR2	93.00 €
	4	CC040VZR2	107.00 €
	5	CC050VZR2	119.00 €
	7	CC070VZR2	151.00 €
	10	CC100VZR2	200.00 €
	15	CC150VZR2	289.00 €
	20	CC200VZR2	359.00 €



Product Line	Length L [m]	Product Name	List Price
Connection Cable Sets	0.5	CC005VZFB2	44.00 €
	1	CC010VZFB2	44.00 €
	1.5	CC015VZFB2	50.00 €
	2	CC020VZFB2	57.00 €
	2.5	CC025VZFB2	63.00 €
	3	CC030VZFB2	69.00 €
	4	CC040VZFB2	102.00 €
	5	CC050VZFB2	113.00 €
	7	CC070VZFB2	140.00 €
	10	CC100VZFB2	180.00 €
	15	CC150VZFB2	248.00 €
	20	CC200VZFB2	314.00 €
Flexible Connection Cable Sets	0.5	CC005VZRB2	95.00 €
	1	CC010VZRB2	95.00 €
	1.5	CC015VZRB2	105.00 €
	2	CC020VZRB2	114.00 €
	2.5	CC025VZRB2	119.00 €
	3	CC030VZRB2	127.00 €
	4	CC040VZRB2	143.00 €
	5	CC050VZRB2	161.00 €
	7	CC070VZRB2	203.00 €
	10	CC100VZRB2	261.00 €
	15	CC150VZRB2	365.00 €
	20	CC200VZRB2	465.00 €

Included

● Motor

Type	Included	Parallel Key	Motor Installation Screw	Operating Manual
Standard	—	—	—	1 Copy
TS Geared	Frame Size 42 mm	—	—	
	Frame Size 60 mm	1 Piece	M4×60 P0.7 (4 Screws)	
FC Geared	1 Piece	—	—	
PS Geared	1 Piece	—	—	
HPG Geared	Shaft Output	1 Piece	—	
	Flange Output	—	—	
Harmonic Geared	1 Piece	—	—	

● For the functions and operation of the product please refer to the operating manual (function edition). The function edition is not included in the product, please contact the nearest sales office or download it from the website.

● Driver

Type	Included	Connector	Operating Manual
Built-in Controller Type	—	· Connector for CN4 (1 Piece) · Connector for CN1 (1 Piece)	1 Copy
Pulse Input Type	—		

● Connection Cable Sets / Flexible Connection Cable Sets

Type	Included	Operating Manual
Connection Cable Sets	—	—
Flexible Connection Cable Sets	—	1 Copy

Standard Type Frame Size 20 mm, 28 mm



Specifications

Motor Product Name	Single Shaft	AZM14AK	AZM15AK	AZM24AK	AZM26AK
Driver Product Name	Built-in Controller Type	AZD-KD			
	Pulse-input Type with RS-485 Communication	AZD-KX			
	Pulse Input Type	AZD-K			
Maximum Holding Torque	N·m	0.02	0.036	0.095	0.19
Holding Torque at Motor Standstill	N·m	0.01	0.018	0.047	0.095
Rotor Inertia	J: kg·m ²	2.7×10^{-7}	3.9×10^{-7}	9.2×10^{-7}	17×10^{-7}
Resolution	Resolution Setting: 1000 P/R	0.36°/Pulse			
Power Supply Input	Voltage	24 VDC ± 5%			
	Input Current	A	0.5	0.6	1.6

Speed - Torque Characteristics (Reference Value)

AZM14

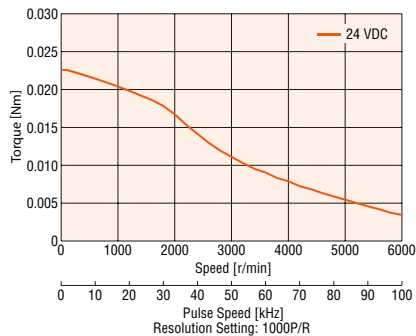

AZM15

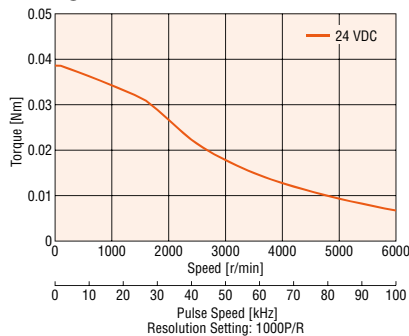

AZM24

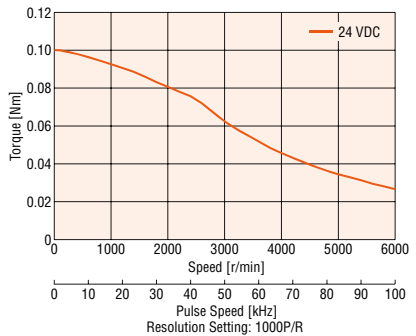

AZM26

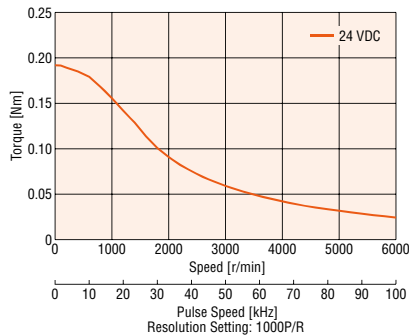

Notes

- The speed-torque characteristics are data based upon our measurement conditions. When these conditions change, these characteristics may change.
- Depending on the driving conditions, a considerable amount of heat may be generated by the motor. Be sure to keep the motor case temperature at 80°C or less in order to protect the ABZO sensor.

Explanation of Terms in Specifications Table

Maximum Holding Torque	The maximum holding torque (holding force) the motor has when power (rated current) is being supplied but the motor shaft is at standstill. (With geared types, the value of holding torque considers the permissible strength of the gear.)	
Permissible Torque	This is the maximum torque continuously applied to the gear output shaft.	
Max. Instantaneous Torque	This is the maximum torque that can be applied to the gear output shaft during acceleration/deceleration, such as when an inertial load is started and stopped.	
Holding Torque at Motor Standstill	When Power is ON	This is the holding torque when the automatic current cutback function is activated.
	Electromagnetic Brake	This is the static friction torque that the electromagnetic brake can generate at rest. (Electromagnetic brake is power off activated type.)

Standard Type Frame Size 42 mm, 60 mm

Specifications



Motor Product Name	Single Shaft	AZM46A□K	AZM48A□K	AZM66A□K	AZM69A□K	
	With Electromagnetic Brake	AZM46M□K	—	AZM66M□K	AZM69M□K	
Driver Product Name	Built-in Controller Type	AZD-KD				
	Pulse-Input Type with RS-485 Communication	AZD-KX				
	Pulse Input Type	AZD-K				
Maximum Holding Torque	Nm	0.3	0.72	1	2	
Holding Torque at Motor Standstill	Power ON	Nm	0.15	0.36	0.5	1
	Electromagnetic Brake	Nm	0.15	—	0.5	1
Rotor Inertia	J: kgm ²	55×10^{-7} (71×10^{-7})*1	115×10^{-7}	370×10^{-7} (530×10^{-7})*1	740×10^{-7} (900×10^{-7})*1	
Resolution	Resolution Setting: 1000 P/R	0.36°/Pulse				
Power Supply Input	Voltage	24 VDC ± 5%*2 / 48 VDC ± 5%*3				
	Input Current	A	1.72 (1.8)*1	2.2	3.55 (3.8)*1	3.45 (3.7)*1

● Either **0** (straight) or **1** (with key) indicating the shaft shape is entered where the box □ is located in the product name. (For **AZM46** straight only). For the one side milled shaft shape no number is specified.

*1 The brackets () indicate the specifications for the product with an electromagnetic brake.

*2 If a 20 m extension cable is used for the electromagnetic brake type, the 24 VDC ± 4% specification applies.

*3 When the motor is operated at 48 VDC input, as a reference, use an inertial load 10 times the rotor inertial ratio or less and twice the safety factor or more when calculating the acceleration torque (excluding **AZM46**).

*4 Only for the Motor.

Speed - Torque Characteristics (Reference Value)

AZM46

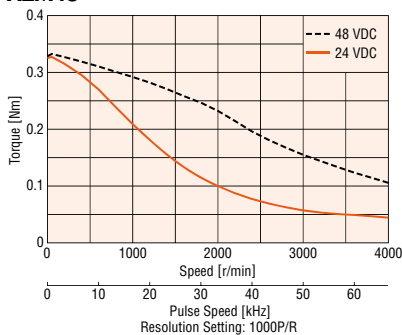

AZM48

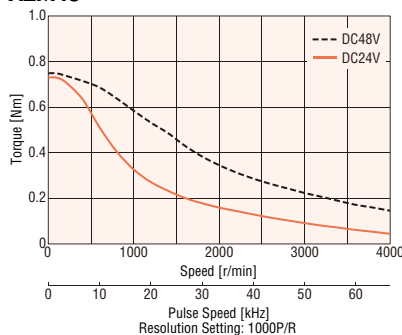

AZM66

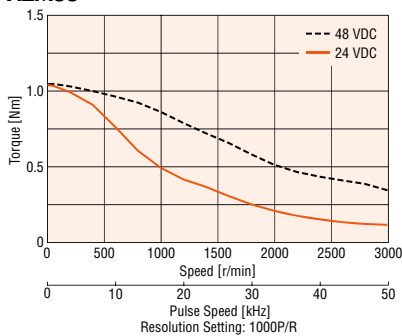

AZM69

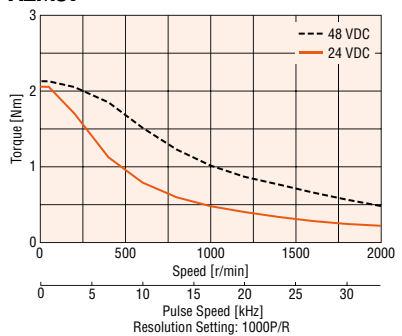

Notes

● The speed-torque characteristics are data based upon our measurement conditions. When these conditions change, these characteristics may change.

● Depending on the driving conditions, a considerable amount of heat may be generated by the motor. Be sure to keep the motor case temperature at 80°C or less in order to protect the ABZO sensor. (When conforming to the UL standards, it is required to keep the temperature of the motor case at 75°C or less, since the motor is recognized as thermal class A.)

TS Geared Type Frame Size 42 mm

Specifications



Motor Product Name	Single Shaft	AZM46AK-TS3.6	AZM46AK-TS7.2	AZM46AK-TS10	AZM46AK-TS20	AZM46AK-TS30	
	With Electromagnetic Brake	AZM46MK-TS3.6	AZM46MK-TS7.2	AZM46MK-TS10	AZM46MK-TS20	AZM46MK-TS30	
Driver Product Name	Built-in Controller Type	AZD-KD					
	Pulse-Input Type with RS-485 Communication	AZD-KX					
	Pulse Input Type	AZD-K					
Maximum Holding Torque	N·m	0.65	1.2	1.7	2	2.3	
Rotor Inertia	J: kg·m ²	55×10 ⁻⁷ (71×10 ⁻⁷)*1					
Gear Ratio		3.6	7.2	10	20	30	
Resolution	Resolution Setting: 1000P/R	0.1°/Pulse	0.05°/Pulse	0.036°/Pulse	0.018°/Pulse	0.012°/Pulse	
Permissible Torque	N·m	0.65	1.2	1.7	2	2.3	
Maximum Instantaneous Torque*	N·m	0.85	1.6	2	*	3	
Holding Torque at Motor Standstill	Power ON	N·m	0.54	1	1.5	1.8	2.3
	Electromagnetic Brake	N·m	0.54	1	1.5	1.8	2.3
Speed Range	r/min	0~833	0~416	0~300	0~150	0~100	
Backlash	arcmin	45 (0.75)	25 (0.42)		15 (0.25)		
Power Supply Input	Voltage	24 VDC±5%*2/48 VDC±5%					
	Input Current	1.72 (1.8)*1					

*For the geared motor output torque, refer to the speed – torque characteristics.

● Either **R** (right), **U** (up) or **L** (left) indicating the cable withdrawing direction is entered where the box □ is located within the product name. For the downward direction no letter is entered in the box □.

*1 The brackets () indicate the specifications for the product with an electromagnetic brake.

*2 If a 20 m extension cable is used for the electromagnetic brake type, the 24 VDC±4% specification applies.

*3 Only for the Motor.

Speed - Torque Characteristics (Reference Value)

AZM46 Gear Ratio 3.6

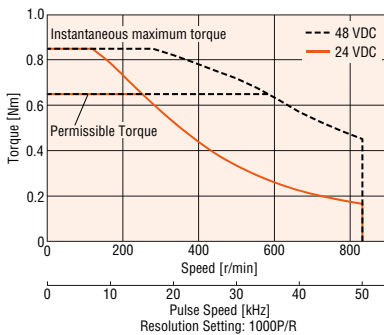

AZM46 Gear Ratio 7.2

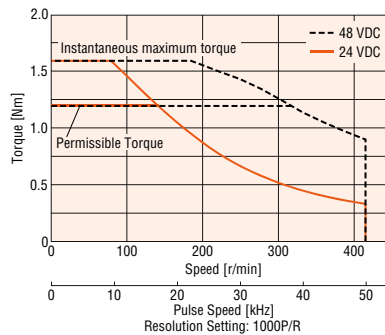

AZM46 Gear Ratio 10

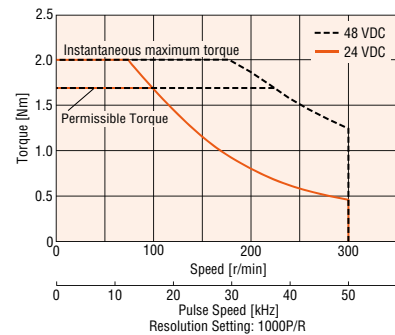

AZM46 Gear Ratio 20

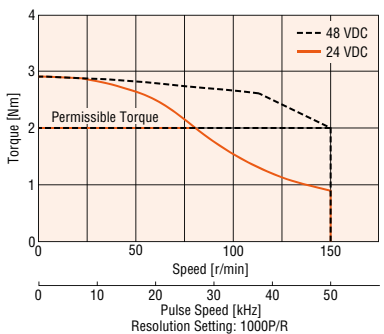

AZM46 Gear Ratio 30

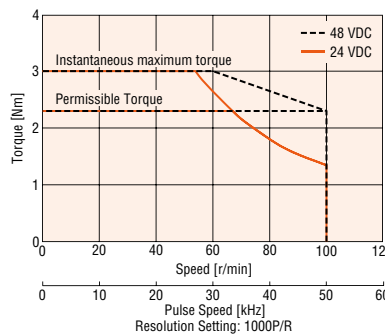

Notes

- The speed-torque characteristics are data based upon our measurement conditions. When these conditions change, these characteristics may change.
- Depending on the driving conditions, a considerable amount of heat may be generated by the motor. Be sure to keep the motor case temperature at 80°C or less in order to protect the ABZO sensor. (When conforming to the UL standards, it is required to keep the temperature of the motor case at 75°C or less, since the motor is recognized as thermal class A.)

Features

System Configuration

Product Line

AC Input

Specifications and Features

Dimensions

Connection and Operation

System Configuration

Product Line

Specifications and Features

DC Input

Dimensions and Operation

Connection and Operation

MultiAxis Driver

Accessories

TS Geared Type Frame Size 60 mm

Specifications



Motor Product Name	Single Shaft	AZM66AK-TS3.6 <input type="checkbox"/>	AZM66AK-TS7.2 <input type="checkbox"/>	AZM66AK-TS10 <input type="checkbox"/>	AZM66AK-TS20 <input type="checkbox"/>	AZM66AK-TS30 <input type="checkbox"/>
	With Electromagnetic Brake	AZM66MK-TS3.6 <input type="checkbox"/>	AZM66MK-TS7.2 <input type="checkbox"/>	AZM66MK-TS10 <input type="checkbox"/>	AZM66MK-TS20 <input type="checkbox"/>	AZM66MK-TS30 <input type="checkbox"/>
Driver Product Name	Built-in Controller Type	AZD-KD				
	Pulse-Input Type with RS-485 Communication	AZD-KX				
	Pulse Input Type	AZD-K				
Maximum Holding Torque	Nm	1.8	3	4	5	6
Rotor Inertia	J: kgm ²	370×10^{-7} (530×10^{-7})* ¹				
Gear Ratio		3.6	7.2	10	20	30
Resolution	Resolution Setting: 1000P/R	0.1°/Pulse	0.05°/Pulse	0.036°/Pulse	0.018°/Pulse	0.012°/Pulse
Permissible Torque	Nm	1.8	3	4	5	6
Maximum Instantaneous Torque*	Nm	*	*	*	8	10
Holding Torque at Power ON	Nm	1.1	2.2	3	5	6
Motor Standstill Electromagnetic Brake	Nm	1.1	2.2	3	5	6
Speed Range	r/min	0~833	0~416	0~300	0~150	0~100
Backlash	arcmin	35 (0.59)		15 (0.25)		10 (0.17)
Power Supply Input	Voltage	$24 \text{ VDC} \pm 5\%^{*2} / 48 \text{ VDC} \pm 5\%^{*3}$				
	Input Current	3.55 (3.8)* ¹				

*For the geared motor output torque, refer to the speed – torque characteristics.

● Either **R** (right), **U** (up) or **L** (left) indicating the cable withdrawing direction is entered where the box is located within the product name. For the downward direction no letter is entered in the box .

*1 The brackets () indicate the specifications for the product with an electromagnetic brake.

*2 If a 20 m extension cable is used for the electromagnetic brake type, the 24 VDC±4% specification applies.

*3 When operating at 48 VDC input, set inertia load to approximately 10 times or less that of the rotor inertia ratio, and twice that of the safety rate when calculating acceleration torque.

*4 Only for the Motor.

Speed - Torque Characteristics (Reference Value)

AZM66 Gear Ratio 3.6

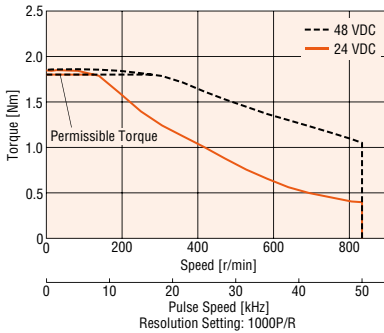

AZM66 Gear Ratio 7.2

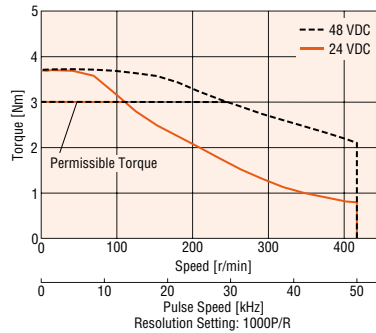

AZM66 Gear Ratio 10

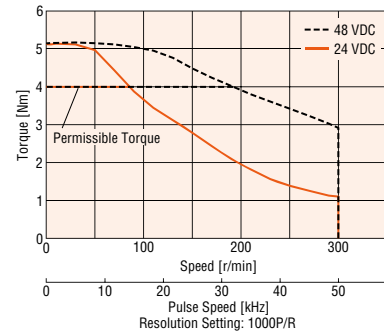

AZM66 Gear Ratio 20

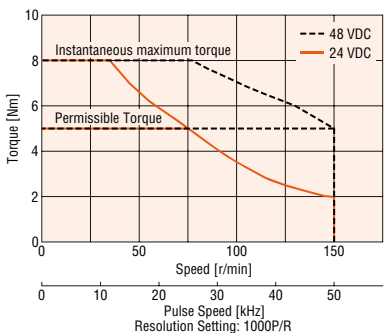

AZM66 Gear Ratio 30

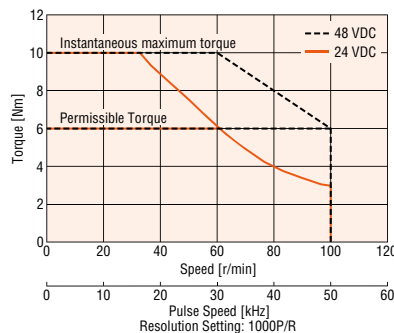

Notes

● The speed-torque characteristics are data based upon our measurement conditions. When these conditions change, these characteristics may change.

● Depending on the driving conditions, a considerable amount of heat may be generated by the motor. Be sure to keep the motor case temperature at 80°C or less in order to protect the ABZO sensor. (When conforming to the UL standards, it is required to keep the temperature of the motor case at 75°C or less, since the motor is recognized as thermal class A.)

FC Geared Type Frame Size 42 mm

Specifications



Motor Product Name	Single Shaft	AZM46AK-FC7.2 <input type="checkbox"/> A	AZM46AK-FC10 <input type="checkbox"/> A	AZM46AK-FC20 <input type="checkbox"/> A	AZM46AK-FC30 <input type="checkbox"/> A	
	With Electromagnetic Brake	AZM46MK-FC7.2 <input type="checkbox"/> A	AZM46MK-FC10 <input type="checkbox"/> A	AZM46MK-FC20 <input type="checkbox"/> A	AZM46MK-FC30 <input type="checkbox"/> A	
Driver Product Name	Built-in Controller Type	AZD-KD				
	Pulse-Input Type with RS-485 Communication	AZD-KX				
	Pulse Input Type	AZD-K				
Maximum Holding Torque	Nm	0.7	1	2	3	
Rotor Inertia	J: kgm ²	55×10 ⁻⁷ (71×10 ⁻⁷)* ¹				
Gear Ratio		7.2	10	20	30	
Resolution	Resolution Setting: 1000P/R	0.05°/Pulse	0.036°/Pulse	0.018°/Pulse	0.012°/Pulse	
Permissible Torque	Nm	0.7	1	2	3	
Holding Torque at	Power ON	Nm	0.7	1	2	3
Motor Standstill	With Electromagnetic Brake	Nm	0.7	1	2	3
Speed Range	r/min	0~416	0~300	0~150	0~100	
Backlash	arcmin	25 (0.42°)		15 (0.25°)		
Power Supply Input	Voltage	24 VDC±5%* ² /48 VDC±5%				
	Input Current	1.72 (1.8)* ³				

● Either **U** (up) or **D** (down) indicating the cable withdrawing direction is entered where the box is located within the product name.

*¹ The brackets () indicate the specifications for the product with an electromagnetic brake.

*² If a 20 m extension cable is used for the electromagnetic brake type, the 24 VDC±4% specification applies.

*³ Only for the Motor.

Speed - Torque Characteristics (Reference Value)

AZM46 Gear Ratio 7.2

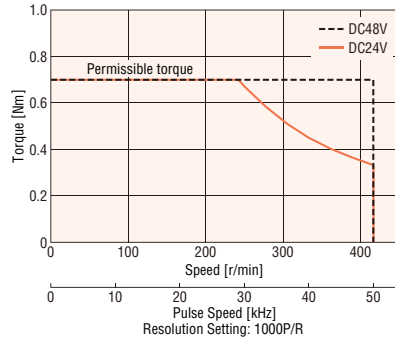

AZM46 Gear Ratio 10

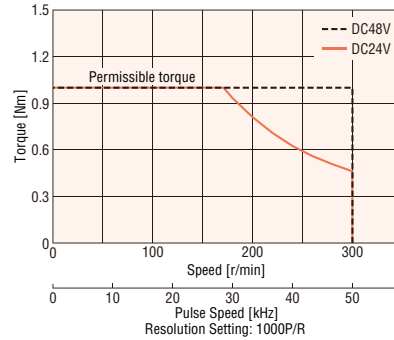

AZM46 Gear Ratio 20

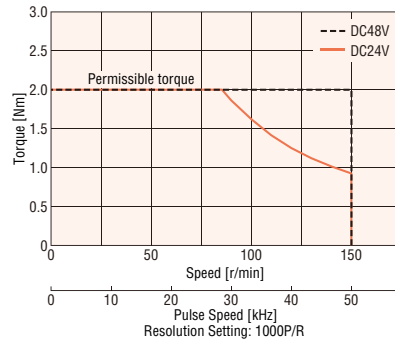

AZM46 Gear Ratio 30

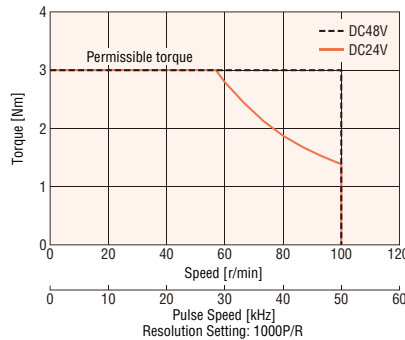

Notes

● The speed-torque characteristics are data based upon our measurement conditions. When these conditions change, these characteristics may change.

● Depending on the driving conditions, a considerable amount of heat may be generated by the motor. Be sure to keep the motor case temperature at 80°C or less in order to protect the ABZO sensor. (When conforming to the UL standards, it is required to keep the temperature of the motor case at 75°C or less, since the motor is recognized as thermal class A.)

FC Geared Type Frame Size 60 mm

Specifications



Motor Product Name	Single Shaft	AZM66AK-FC7.2□A	AZM66AC-FC10□A	AZM66AK-FC20□A	AZM66AK-FC30□A	
	With Electromagnetic Brake	AZM66MK-FC7.2□A	AZM66MC-FC10□A	AZM66MK-FC20□A	AZM66MK-FC30□A	
Driver Product Name	Built-in Controller Type	AZD-KD				
	Pulse-Input Type with RS-485 Communication	AZD-KX				
	Pulse Input Type	AZD-K				
Maximum Holding Torque	Nm	2.5	3.5	7	10	
Rotor Inertia	J: kgm ²	370×10 ⁻⁷ (530×10 ⁻⁷)*1				
Gear Ratio		7.2	10	20	30	
Resolution	Resolution Setting: 1000P/R	0.05°/Pulse	0.036°/Pulse	0.018°/Pulse	0.012°/Pulse	
Permissible Torque	Nm	2.5	3.5	7	10	
Holding Torque at	Power ON	Nm	2.5	3.5	7	10
Motor Standstill	With Electromagnetic Brake	Nm	2.5	3.5	7	10
Speed Range	r/min	0~416	0~300	0~150	0~100	
Backlash	arcmin	15 (0.25°)		10 (0.17°)		
Power Supply Input	Voltage	24 VDC±5%*2/48 VDC±5%*3				
	Input Current	3.35 (3.8)*1				

● Either **U** (up) or **D** (down) indicating the cable withdrawing direction is entered where the box □ is located within the product name.

*1 The brackets () indicate the specifications for the product with an electromagnetic brake.

*2 If a 20 m extension cable is used for the electromagnetic brake type, the 24 VDC±4% specification applies.

*3 When operating at 48 VDC input, set inertia load to approximately 10 times or less that of the rotor inertia ratio, and twice that of the safety rate when calculating acceleration torque.

*4 Only for the Motor.

Speed - Torque Characteristics (Reference Value)

AZM66 Gear Ratio 7.2

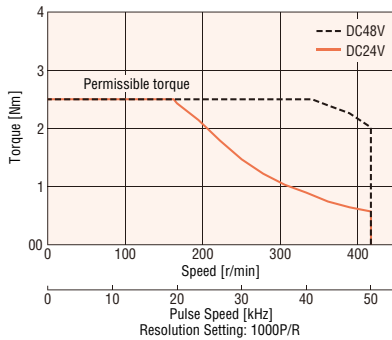

AZM66 Gear Ratio 10

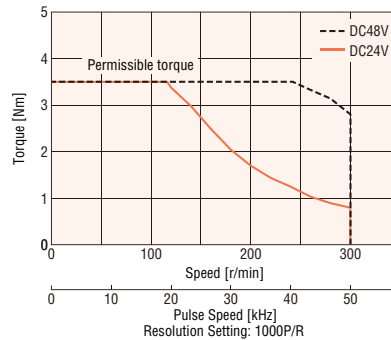

AZM66 Gear Ratio 20

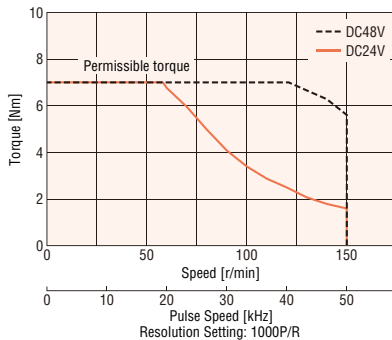

AZM66 Gear Ratio 30

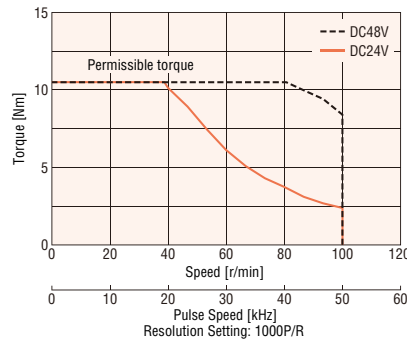

Notes

● The speed-torque characteristics are data based upon our measurement conditions. When these conditions change, these characteristics may change.

● Depending on the driving conditions, a considerable amount of heat may be generated by the motor. Be sure to keep the motor case temperature at 80°C or less in order to protect the ABZO sensor. (When conforming to the UL standards, it is required to keep the temperature of the motor case at 75°C or less, since the motor is recognized as thermal class A.)

PS Geared Type Frame Size 42 mm

Specifications



Motor Product Name	Single Shaft	AZM46AK-PS5	AZM46AK-PS7.2	AZM46AK-PS10	AZM46AK-PS25	AZM46AK-PS36	AZM46AK-PS50
Motor Product Name	With Electromagnetic Brake	AZM46MK-PS5	AZM46MK-PS7.2	AZM46MK-PS10	AZM46MK-PS25	AZM46MK-PS36	AZM46MK-PS50
Driver Product Name	Built-in Controller Type	AZD-KD					
Driver Product Name	Pulse-Input Type with RS-485 Communication	AZD-KX					
	Pulse Input Type	AZD-K					
Maximum Holding Torque	Nm	1	1.5	2.5	3		
Rotor Inertia	J: kgm ²	55×10 ⁻⁷ (71×10 ⁻⁷)*1					
Gear Ratio		5	7.2	10	25	36	50
Resolution	Resolution Setting: 1000P/R	0.072°/Pulse	0.05°/Pulse	0.036°/Pulse	0.0144°/Pulse	0.01°/Pulse	0.0072°/Pulse
Permissible Torque	Nm	1	1.5	2.5	3		
Maximum Instantaneous Torque*	Nm	*	2	6	*	6	
Holding Torque at Power ON	Nm	0.75	1	1.5	2.5	3	
Motor Standstill Electromagnetic Brake	Nm	0.75	1	1.5	2.5	3	
Speed Range	r/min	0~600	0~416	0~300	0~120	0~83	0~60
Backlash	arcmin	15 (0.25°)					
Power Supply Input	Voltage	24 VDC±5%*2/48 VDC±5%					
Power Supply Input	Input Current	1.72 (1.8)*1					

*For the geared motor output torque, refer to the speed – torque characteristics.

*1 The brackets () indicate the specifications for the product with an electromagnetic brake.

*2 If a 20 m extension cable is used for the electromagnetic brake type, the 24 VDC±4% specification applies.

*3 Only for the Motor.

Speed - Torque Characteristics (Reference Value)

AZM46 Gear Ratio 5

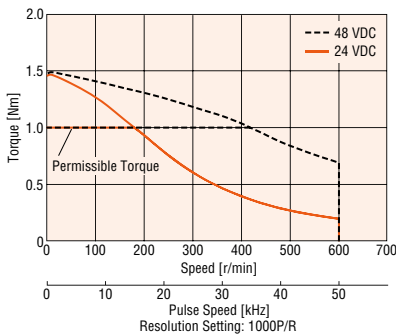

AZM46 Gear Ratio 7.2

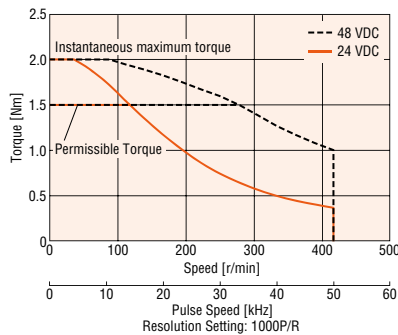

AZM46 Gear Ratio 10

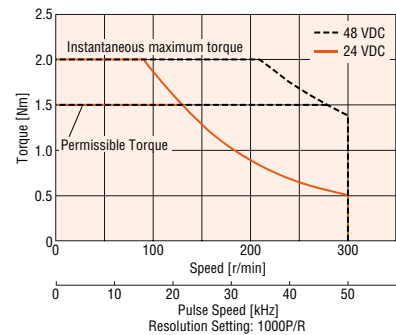

AZM46 Gear Ratio 25

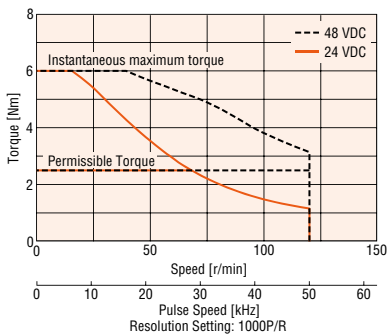

AZM46 Gear Ratio 36

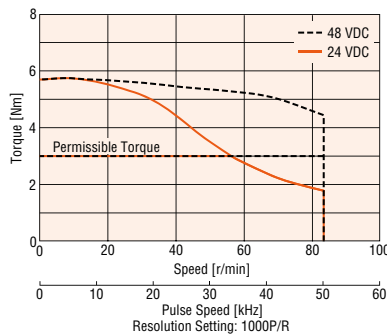

AZM46 Gear Ratio 50

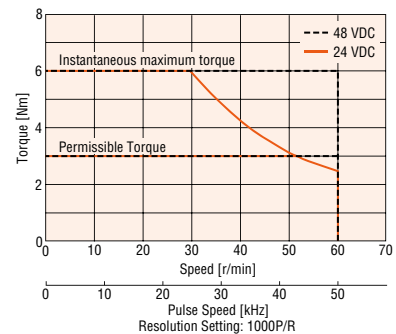

Notes

- The speed-torque characteristics are data based upon our measurement conditions. When these conditions change, these characteristics may change.
- Depending on the driving conditions, a considerable amount of heat may be generated by the motor. Be sure to keep the motor case temperature at 80°C or less in order to protect the ABZO sensor. (When conforming to the UL standards, it is required to keep the temperature of the motor case at 75°C or less, since the motor is recognized as thermal class A.)

Features
 System Configuration
 Product Line
 Specifications and Features
 Dimensions
 Connection and Operation
 System Configuration
 Product Line
 Specifications and Features
 DC Input
 Dimensions
 Connection and Operation
 Multiaxis Driver
 Accessories

PS Geared Type Frame Size 60 mm

Specifications



Motor Product Name	Single Shaft	AZM66AK-PS5	AZM66AK-PS7.2	AZM66AK-PS10	AZM66AK-PS25	AZM66AK-PS36	AZM66AK-PS50
	With Electromagnetic Brake	AZM66MK-PS5	AZM66MK-PS7.2	AZM66MK-PS10	AZM66MK-PS25	AZM66MK-PS36	AZM66MK-PS50
Driver Product Name	Built-in Controller Type	AZD-KD					
	Pulse-Input Type with RS-485 Communication	AZD-KX					
	Pulse Input Type	AZD-K					
Maximum Holding Torque	Nm	3.5	4	5	8		
Rotor Inertia	J: kgm ²	370×10^{-7} (530×10^{-7})* ¹					
Gear Ratio		5	7.2	10	25	36	50
Resolution	Resolution Setting: 1000P/R	0.072°/Pulse	0.05°/Pulse	0.036°/Pulse	0.0144°/Pulse	0.01°/Pulse	0.0072°/Pulse
Permissible Torque	Nm	3.5	4	5	8		
Maximum Instantaneous Torque*	Nm	*	*	*	*	*	20
Holding Torque at Power ON	Nm	2.5	3.6	5	7.6	8	
Motor Standstill Electromagnetic Brake	Nm	2.5	3.6	5	7.6	8	
Speed Range	r/min	0~600	0~416	0~300	0~120	0~83	0~60
Backlash	arcmin	7 (0.12°)			9 (0.15°)		
Power Supply Input	Voltage	24 VDC ± 5%* ² / 48 VDC ± 5%* ³					
	Input Current	3.55 (3.8)* ¹ A					

*For the geared motor output torque, refer to the speed – torque characteristics.

*1 The brackets () indicate the specifications for the product with an electromagnetic brake.

*2 If a 20 m extension cable is used for the electromagnetic brake type, the 24 VDC ± 4% specification applies.

*3 When operating at 48 VDC input, set inertia load to approximately 10 times or less that of the rotor inertia ratio, and twice that of the safety rate when calculating acceleration torque.

*4 Only for the Motor.

Speed - Torque Characteristics (Reference Value)

AZM66 Gear Ratio 5

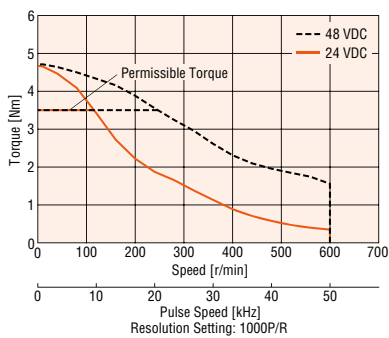

AZM66 Gear Ratio 7.2

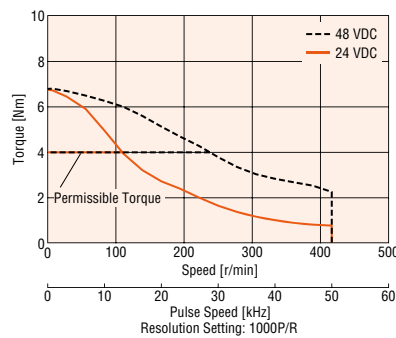

AZM66 Gear Ratio 10

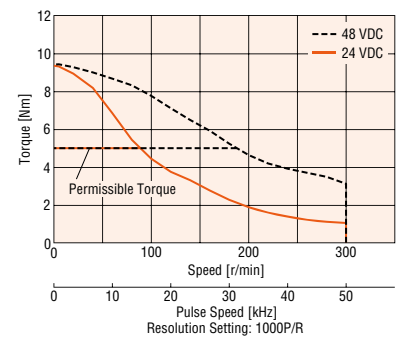

AZM66 Gear Ratio 25

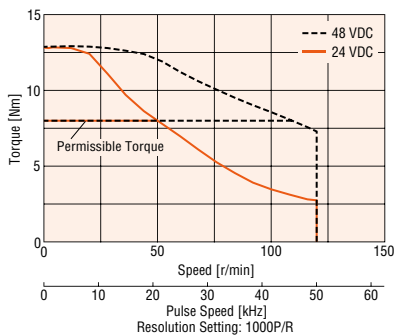

AZM66 Gear Ratio 36

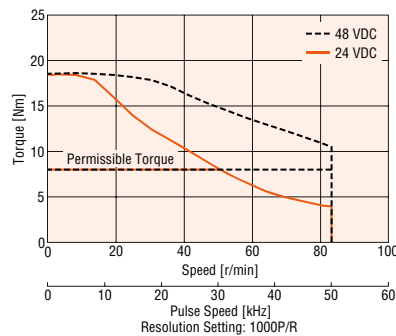

AZM66 Gear Ratio 50

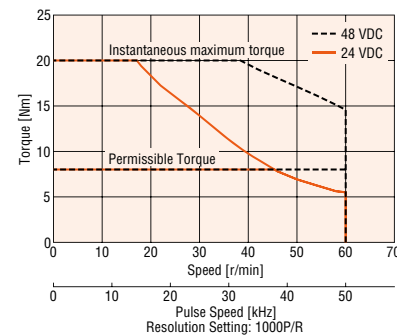

Notes

- The speed-torque characteristics are data based upon our measurement conditions. When these conditions change, these characteristics may change.
- Depending on the driving conditions, a considerable amount of heat may be generated by the motor. Be sure to keep the motor case temperature at 80°C or less in order to protect the ABZO sensor. (When conforming to the UL standards, it is required to keep the temperature of the motor case at 75°C or less, since the motor is recognized as thermal class A.)

HPG Geared Type Frame Size 40 mm, 60 mm

Specifications



Motor Product Name	Single Shaft	AZM46AK-HP5□	AZM46AK-HP9□	AZM66AK-HP5□	AZM66AK-HP15□	
	With Electromagnetic Brake	AZM46MK-HP5□	AZM46MK-HP9□	AZM66MK-HP5□	AZM66MK-HP15□	
Driver Product Name	Built-in Controller Type	AZD-KD				
	Pulse-Input Type with RS-485 Communication	AZD-KX				
	Pulse Input Type	AZD-K				
Maximum Holding Torque	Nm	1.5	2.5	5	9	
Rotor Inertia	J: kgm ²	55×10 ⁻⁷ (71×10 ⁻⁷)*1		370×10 ⁻⁷ (530×10 ⁻⁷)*1		
Inertia*2	J: kgm ²	5.8×10 ⁻⁷ (4.2×10 ⁻⁷)	3.4×10 ⁻⁷ (2.9×10 ⁻⁷)	92×10 ⁻⁷ (86×10 ⁻⁷)	78×10 ⁻⁷ (77×10 ⁻⁷)	
Gear Ratio		5	9	5	15	
Resolution	Resolution Setting: 1000P/R	0.072°/Pulse	0.04°/Pulse	0.072°/Pulse	0.024°/Pulse	
Permissible Torque*	Nm	*	2.5	*	9	
Maximum Instantaneous Torque*	Nm	*	*	*	*	
Holding Torque at	Power ON	Nm	0.75	1.35	2.5	7.5
Motor Standstill	Electromagnetic Brake	Nm	0.75	1.35	2.5	7.5
Speed Range	r/min	0~800	0~444	0~600	0~200	
Backlash	arcmin	3 (0.05°)				
Power Supply Input	Voltage	24 VDC±5%*4/48 VDC±5%*5				
	Input Current	A	1.72 (1.8)*1		3.55 (3.8)*1	
Output Flange Surface Runout*3	mm	0.02			0.04	
Output Flange Inner Runout*3	mm	0.03			0.04	

*For the output torque as a geared motor, see the speed-torque characteristics.

● For the flange output type, **F** is specified where the box □ is located in the product name.

*1 The values inside the brackets () represent the specification for the electromagnetic brake type.

*2 This is the value with the inertia moment inside the gear section converted into the motor shaft. The value within () is the flange output type.

*3 This is the flange output type value.

*4 If a 20 m extension cable is used for the electromagnetic brake type, the 24 VDC±4% specification applies.

*5 When operating at 48 VDC input, set inertia load to approximately 10 times or less that of the rotor inertia ratio, and twice that of the safety rate when calculating acceleration torque. (excluding

AZM46)

*6 Only for the Motor.

Speed - Torque Characteristics (Reference Value)

AZM46 Gear Ratio 5

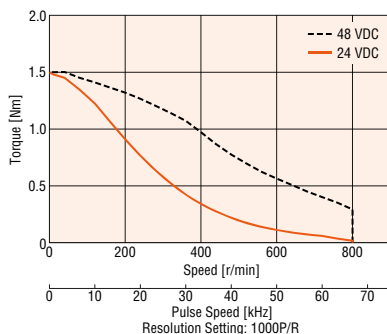

AZM46 Gear Ratio 9

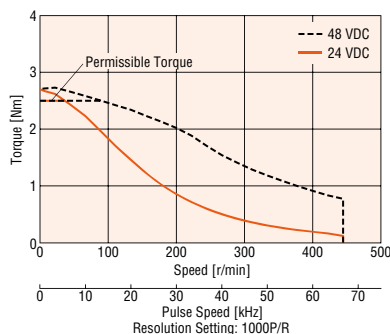

AZM66 Gear Ratio 5

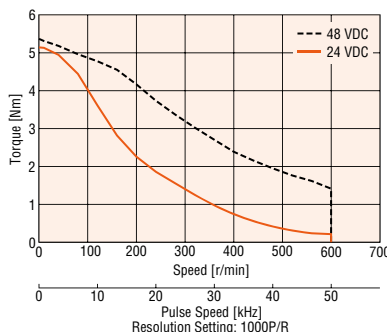

AZM66 Gear Ratio 15

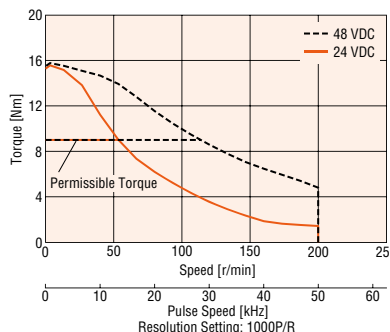

Notes

● The speed-torque characteristics are data based upon our measurement conditions. When these conditions change, these characteristics may change.

● Depending on the driving conditions, a considerable amount of heat may be generated by the motor. Be sure to keep the motor case temperature at 80°C or less in order to protect the ABZO sensor. (When conforming to the UL standards, it is required to keep the temperature of the motor case at 75°C or less, since the motor is recognized as thermal class A.)

Harmonic Geared Type Frame Size 42 mm, 60 mm

Specifications



Motor Product Name	Single Shaft	AZM46AK-HS50	AZM46AK-HS100	AZM66AK-HS50	AZM66AK-HS100
	With Electromagnetic Brake	AZM46MK-HS50	AZM46MK-HS100	AZM66MK-HS50	AZM66MK-HS100
Driver Product Name	Built-in Controller Type	AZD-KD			
	Pulse Input Type with RS-485 Communication	AZD-KX			
	Pulse Input Type	AZD-K			
Maximum Holding Torque	Nm	3.5	5	7	10
Rotor Inertia	J: kgm ²	72×10 ⁻⁷ (88×10 ⁻⁷)*1		405×10 ⁻⁷ (565×10 ⁻⁷)*1	
Gear Ratio		50	100	50	100
Resolution	Resolution Setting: 1000P/R	0.0072 ² /Pulse	0.0036 ² /Pulse	0.0072 ² /Pulse	0.0036 ² /Pulse
Permissible Torque	Nm	3.5	5	7	10
Maximum Instantaneous Torque*	Nm	8.3	11	*	36
Holding Torque at Power ON	Nm	3.5	5	7	10
Motor Standstill Electromagnetic Brake	Nm	3.5	5	7	10
Speed Range	r/min	0~70	0~35	0~60	0~30
Lost Motion (Load Torque)	arcmin	1.5 Max. (±0.16 N·m)	1.5 Max. (±0.20 N·m)	0.7 Max. (±0.28 N·m)	0.7 Max. (±0.39 N·m)
Power Supply Input	Voltage	24 VDC±5%*2/48 VDC±5%*3			
	Input Current	1.72 (1.8)*1		3.55 (3.8)*1	

*For the output torque as a geared motor, see the speed-torque characteristics.

*1 The values inside the brackets () represent the specification for the electromagnetic brake type.

*2 If a 20 m extension cable is used for the electromagnetic brake type, the 24 VDC±4% specification applies.

*3 When operating at 48 VDC input, set inertia load to approximately 10 times or less that of the rotor inertia ratio, and twice that of the safety rate when calculating acceleration torque. (excluding

AZM46)

*4 Only for the Motor.

Notes

● The rotor inertia represents a sum of the moments of inertia of the harmonic gear converted to motor shaft values.

Speed - Torque Characteristics (Reference Value)

AZM46 Gear Ratio 50

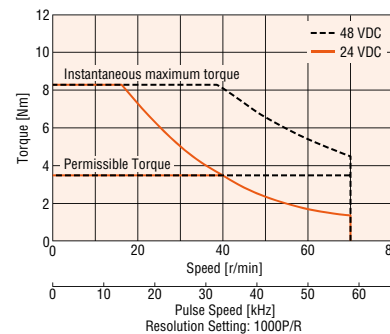

AZM46 Gear Ratio 100

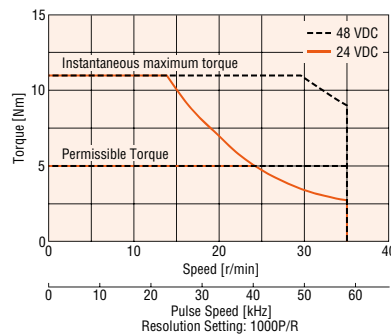

AZM66 Gear Ratio 50

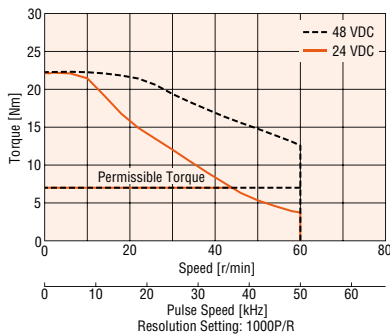

AZM66 Gear Ratio 100

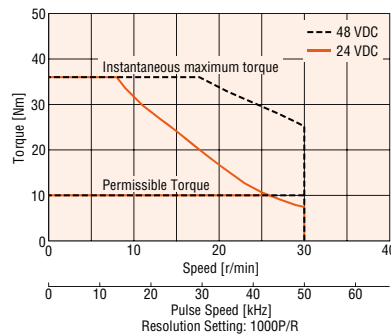

Notes

● The speed-torque characteristics are data based upon our measurement conditions. When these conditions change, these characteristics may change.

● Depending on the driving conditions, a considerable amount of heat may be generated by the motor. Be sure to keep the motor case temperature at 80°C or less in order to protect the ABZO sensor. (When conforming to the UL standards, it is required to keep the temperature of the motor case at 75°C or less, since the motor is recognized as thermal class A.)

Driver Specifications

Driver	Built-in Controller	Pulse-Input with RS-485 Communication	Pulse Input		
Driver Product Name	AZD-KD	AZD-KX	AZD-K		
I/O Function	Max. Input Pulse Frequency	—	Line driver output by programmable controller: 1 MHz (When the pulse duty is 50%) Open-collector output by programmable controller: 250 kHz (When the pulse duty is 50%) Negative Logic Pulse Input (Initial value)		
	Number of Positioning Data Sets	256	256 *1		
	Direct Inputs	10	6		
	Direct Outputs		6		
	RS-485 Communication Network Inputs	16	—		
	RS-485 Communication Network Outputs	16	—		
Setting Tool	Data Setting Software MEXE02		○		
Coordinates Management Method		Battery-free Absolute System			
Operation	Operating Method	Positioning operation	○	○*1	
		Positioning Push-Motion Operation*2	○	○*1	
	Positioning Operation	Connecting Method	Independent Operation	○	○*1
			Sequential Operation	○	○*1
		Multistep Speed-Change (Configuration Connection)	○	○*1	
	Sequence Control	Loop Operation (Repeating)	○	○*1	
		Event Jump Operation	○	○*1	
	Continuous Operation	Position Control	○	○*1	
		Speed Control	○	○*1	
		Torque Control	○	○*1	
Push-Motion*2		○	○*1		
Return-to-Home Operation	Return-to-Home Operation	○	○		
	High Speed Return-to-Home Operation	○	○		
JOG Operation		○	○		
Monitor/Information	Waveform Monitoring	○	○		
	Overload Detection	○	○		
	Overheat Detection (Motor · Driver)	○	○		
	Position · Speed Information	○	○		
	Temperature Detection (Motor · Driver)	○	○		
	Motor Load Factor	○	○		
Alarm	Traveled Distance/Cumulated Traveled Distance	○	○		
		○	○		

*1 This can be used by setting with the data setting software **MEXE02**.

*2 Push-motion can not be used with a geared motor.

RS-485 Communication Specifications

Protocol	Modbus RTU Mode
Electrical Characteristics	EIA-485 Based, Straight Cable Use shielded twisted-pair cables (TIA/EIA-568B CAT5e or better recommended). The max. total extension length is 50 m.
Communication Mode	Half duplex and start-stop synchronization (data: 8 bits, stop bit: 1 bit or 2 bits, parity: none, even, or odd)
Baud Rate	9600 bps/19200 bps/38400 bps/57600 bps/115200 bps/230400 bps are available
Connection Type	Up to 31 units can be connected to a single programmable controller (master equipment).

Electromagnetic Brake Specifications

Product Name	AZM46	AZM66	AZM69
Type	Power Off Activated Type		
Power Supply Voltage	24 VDC ±5%*		
Power Supply Current	A	0.08	0.25
Brake Activation Time	ms	20	
Brake Release Time	ms	30	
Time Rating	Continuous		

*If a 20 m extension cable is used for the electromagnetic brake type, the 24 VDC±4% specification applies.

● The product names are listed such that the product names are identifiable.

General Specifications

		Motor	Driver
Thermal Class		[UL 105 (A) certified]	—
Insulation Resistance		100 MΩ or more when a 500 VDC megger is applied between the following places: • Case – Motor Windings • Case – Electromagnetic Brake Windings*1	100 MΩ or more when a 500 VDC megger is applied between the following places: • Protective Earth Terminal – Power Supply Terminal
Dielectric Voltage		Sufficient to withstand the following for 1 minute: AZM14, AZM15, AZM24, AZM26 • Case – Motor Windings 0.5 kVAC, 50 Hz or 60 Hz AZM46, AZM48, AZM66, AZM69 • Case – Motor Windings 1.0 kVAC, 50 Hz or 60 Hz • Case – Electromagnetic Brake Windings*1 1.0 kVAC 50 Hz or 60 Hz	—
Operating Environment (In operation)	Ambient Temperature	0~+40°C (Non-freezing)	0~+50°C (Non-freezing)
	Ambient Humidity	85% or less (Non-condensing)	
	Atmosphere	No corrosive gases or dust. The product should not be exposed to water, oil or other liquids.	
Degree of Protection		AZM14, AZM15, AZM24, AZM26: IP40 (excluding installation surfaces and connector locations) AZM46, AZM48, AZM66, AZM69: IP66 (excluding installation surfaces and connector locations)	IP10
Stop Position Accuracy		AZM14, AZM15, AZM24, AZM26: ±5 minutes (±0.083°) AZM46, AZM48: ±4 minutes (±0.067°) AZM66, AZM69: ±3 minutes (±0.05°)	
Shaft Runout		0.05 T.I.R. (mm)*2	—
Concentricity of Installation Pilot to the Shaft		0.075 T.I.R. (mm)*2	—
Perpendicularity of Installation Surface to the Shaft		0.075 T.I.R. (mm)*2	—
Multiple Rotation Detection Range Upon Power OFF		AZM14, AZM15, AZM24, AZM26: ±450 rotations (900 rotations) AZM46, AZM48, AZM66, AZM69: ±900 rotations (1,800 rotations)	

*1 Only for products with an electromagnetic brake.

*2 T. I. R. (Total Indicator Reading): The total dial gauge reading when the measurement section is rotated once around the reference axis center.

Note

- Do not measure insulation resistance or perform a dielectric strength test while the motor and driver are connected. Also, do not perform these tests on the motor absolute sensor part.

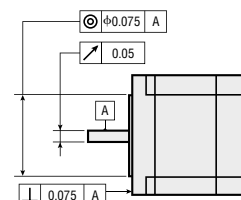

Rotation Direction

This refers to the direction viewed from the output shaft side.

The rotation direction of the gear output shaft with respect to the standard type motor output shaft differs depending on the type of gear and gear ratio.

Refer to the following table.

	Gear Ratio	Rotation Direction with Respect to Motor Output Shaft
TS Gear	3.6, 7.2, 10	Same direction
	20, 30	Opposite direction
FC Gear	All gear ratios	Same direction
PS Gear		Same direction
HPG Gear		Same direction
Harmonic Gear	All gear ratios	Opposite direction

Standard Type Motor

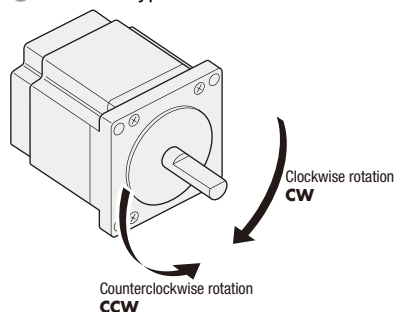

Motor Installation

Since the ABZO sensor is easily affected by a magnetic field, make sure the installation location.

Motor installation of frame size 28 mm or smaller

When motors are installed side by side, ensure the distance among motors or more than the frame size in horizontal and vertical directions.

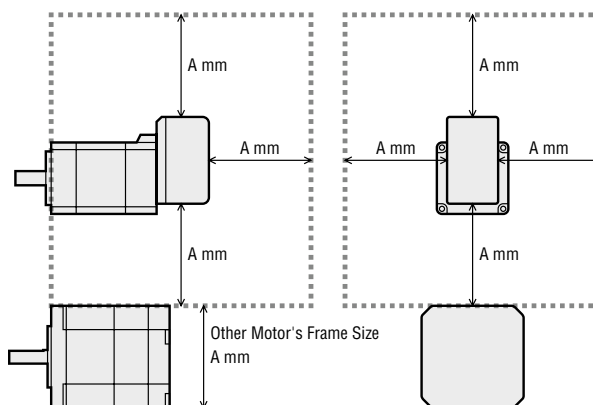

Reference

The other motor [mm]	A [mm]
Frame Size 20	20
Frame Size 28	28
Frame Size 42	42
Frame Size 60	60

- Leave a minimum distance of the other motor's frame size (A mm) or larger.

- Motor Installation within an Magnetic Field ensure that the magnetic flux density of the ABZO sensor surface does not exceed the values shown in the overview.

Motor Frame Size [mm]	Magnetic Flux Density
28 or smaller	2mT*
42 or larger	10mT

*Between 1-2 mT ensure that the ambient temperature is between 20-40 °C.

Permissible Radial Load and Permissible Axial Load

Unit: N

	Motor Frame Size [mm]	Product	Gear Ratio	Permissible Radial Load					Permissible Axial Load
				Distance from Shaft End [mm]					
				0	5	10	15	20	
Standard	20	AZM14, AZM15	-	12	15	-	-	-	3
	28	AZM24, AZM26		25	34	52	-	-	5
	42	AZM46		35	44	58	85	-	15
		AZM48		30	35	44	58	85	
60	AZM66, AZM69	90	100	130	180	270	30		
TS Gear	42	AZM46	3.6, 7.2, 10	20	30	40	50	-	15
			20, 30	40	50	60	70	-	
	60	AZM66	3.6, 7.2, 10	120	135	150	165	180	40
FC Gear	42	AZM46	7.2, 10, 20, 30	170	185	200	215	230	100
	60	AZM66		180	200	220	250	-	
PS Gear	42	AZM46	5	70	80	95	120	-	100
			7.2	80	90	110	140	-	
			10	85	100	120	150	-	
			25	120	140	170	210	-	
			36	130	160	190	240	-	
	60	AZM66	5	170	200	230	270	320	200
			7.2	200	220	260	310	370	
			10	220	250	290	350	410	
			25	300	340	400	470	560	
			36	340	380	450	530	630	
HPG Gear	40	AZM46	5	150	170	190	230	270	430
			9	180	200	230	270	320	510
	60	AZM66	5	250	270	300	330	360	700
Harmonic Gear	42	AZM46	50, 100	360	380	420	460	510	980
	60	AZM66		180	220	270	360	510	220
				320	370	440	550	720	450

- The products can be identified with the detailed product code.
- The **PS** geared type, **PN** geared type, and **HPG** geared type have a full lifetime of 20,000 hours when either the permissible radial load or the permissible axial load is applied. For **TS** and Harmonic geared types lifetime please contact the nearest Oriental Motor sales office.

Radial Load and Axial Load

Distance from Shaft End [mm]

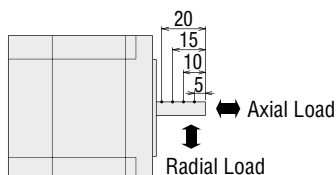

Permissible Moment Load

If an excentric load is applied when attaching an arm or table to the flange face, calculate the moment load with the following formula. The moment load should not exceed the permissible values shown in the table below.

HPG Gear Flange Output

Product Name	Gear Ratio	Permissible Axial Load [N]	Permissible Moment Load [Nm]	Coefficient a [m]
AZM46	5	430	4.9	0.006
	9	510	5.9	
AZM66	5	700	12.0	0.011
	15	980	17.2	

m: Work mass [kg]
g : Gravitational acceleration [m/s²]
F : External force [N]
L : Distance from center of output flange
a : Coefficient [m]
deltaF : Load on output flange side [N]
Fs : Permissible axial load [N]
deltaM: Moment load [Nm]
M: Permissible moment load [Nm]

The required moment load can be calculated according to the following formula.

Example 1: When external force F [N] is applied at a distance of L [m] from the centre of the output flange

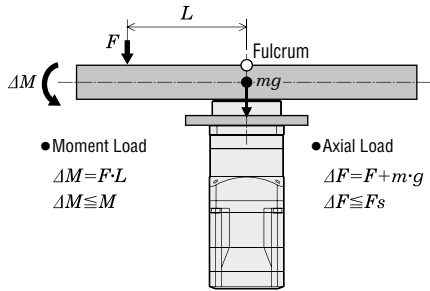

Example 2: When external force F [N] is applied at a distance of L [m] from the surface mounting of the output flange

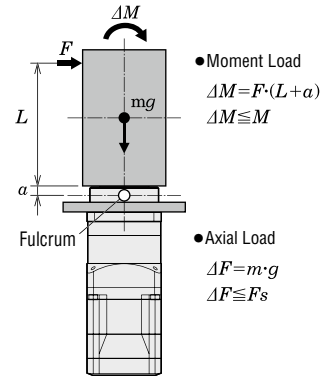

Harmonic Gear

Product Name	Permissible Axial Load [N]	Permissible Moment Load [Nm]	Coefficient a [m]
AZM46	220	5.6	0.009
AZM66	450	11.6	0.0114

The required moment load can be calculated according to the following formula.

Example 1: When external force F (N) is applied at a distance of L (m) from the centre of the output flange

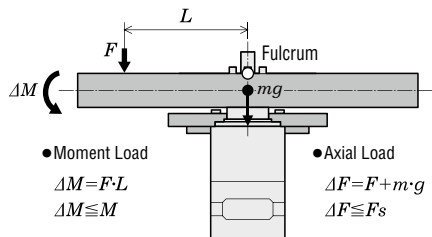

Example 2: When external force F (N) is applied at a distance of L (m) from the surface mounting of the output flange

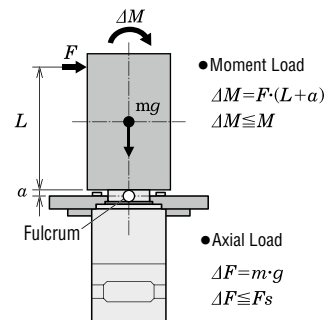

Load Torque - Driver Input Current Characteristics

The following are the relationships between the load torque and driver input current at each speed when the motor is operated. From these characteristics, it is possible to estimate the current capacity actually required when used with multiple axes. For geared motors, convert to torque and speed at the motor shaft.

$$\text{Motor shaft speed} = \text{Gear output shaft speed} \times \text{Gear ratio} \text{ [r/min]}$$

$$\text{Motor shaft torque} = \frac{\text{Gear output shaft torque}}{\text{Gear Ratio}} \text{ [Nm]}$$

24 VDC

AZM14

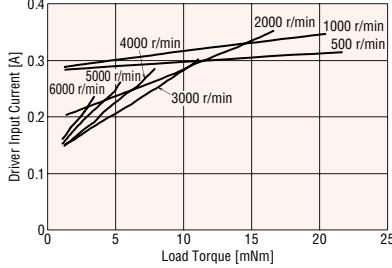

AZM15

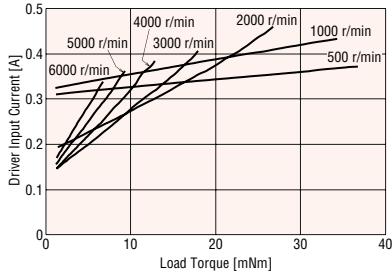

AZM24

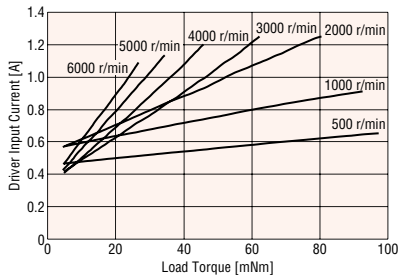

AZM26

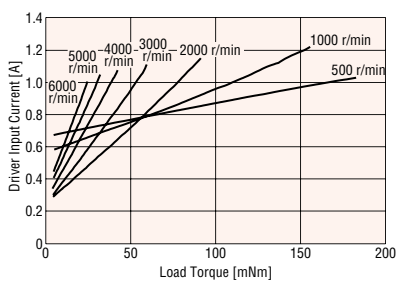

AZM46

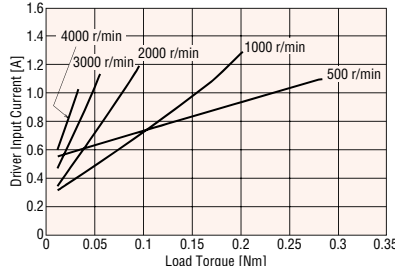

AZM48

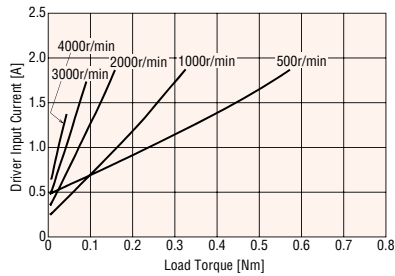

AZM66

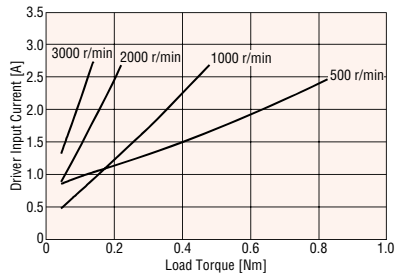

AZM69

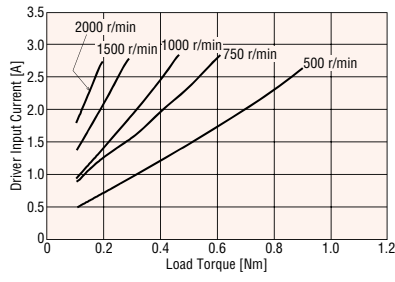

48 VDC

AZM46

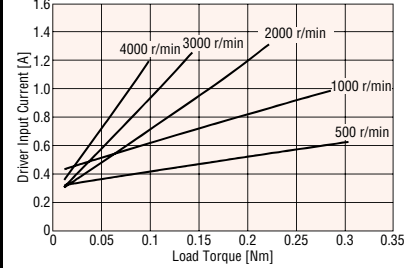

AZM48

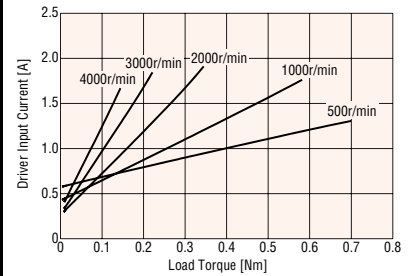

AZM66

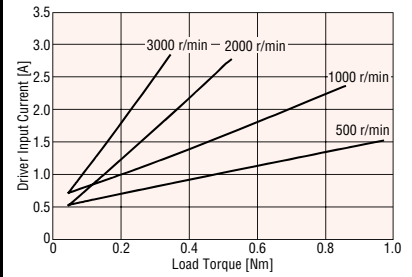

AZM69

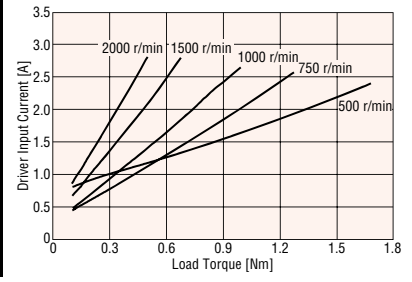

Features
System Configuration
Product Line
Specifications and Features
Dimensions
Connection and Operation
System Configuration
Product Line
Specifications and Features
Dimensions
Connection and Operation
Multiaxis Driver
Accessories

Dimensions (Unit = mm)

● Motors

◇ Standard

Frame Size 20 mm

Product Name	L	Mass [kg]
AZM14AK	50	0.08
AZM15AK	60	0.1

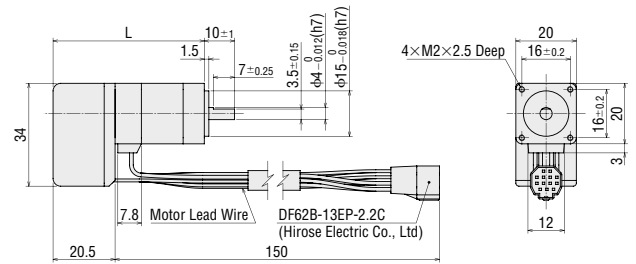

Frame Size 28 mm

Product Name	L	Mass [kg]
AZM24AK	54.5	0.15
AZM26AK	74	0.24

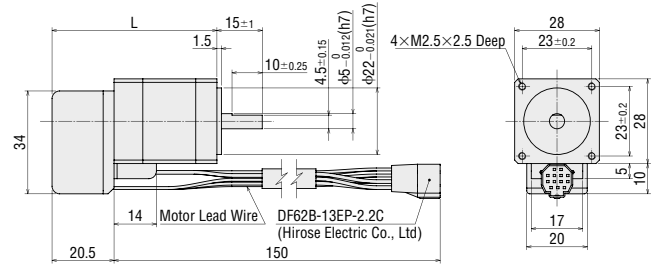

Frame Size 42 mm

Product Name	Mass [kg]
AZM46A□K	0.44

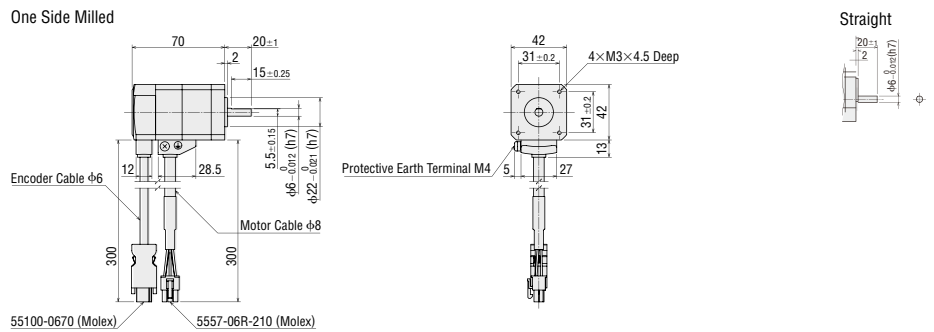

Frame Size 42 mm

Product Name	Mass [kg]
AZM48A□K	0.68

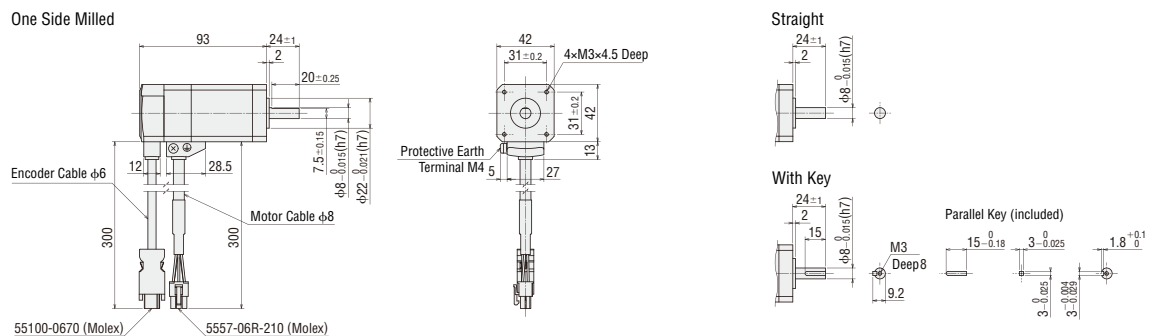

● Either 0 (straight) or 1 (with key) indicating the shaft shape is entered where the box □ is located within the product name. (For **AZM46** straight only).

Frame Size 60 mm

Product Name	L	Mass [kg]
AZM66A □K	72	0.91
AZM69A □K	97.5	1.4

One Side Milled

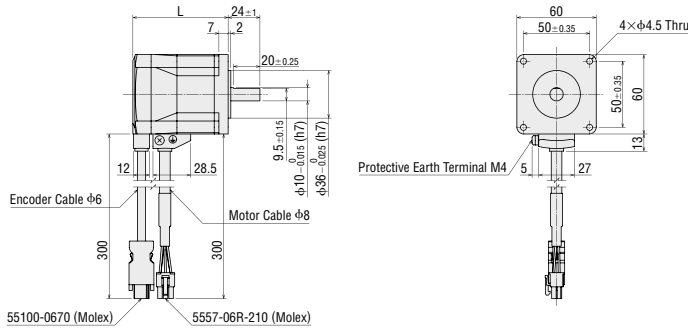

Straight

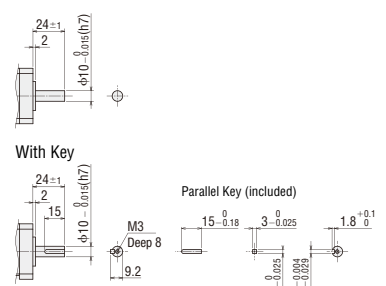

◇ Standard Type with Electromagnetic Brake

Frame Size 42 mm

Product Name	Mass [kg]
AZM46M □K	0.61

One Side Milled

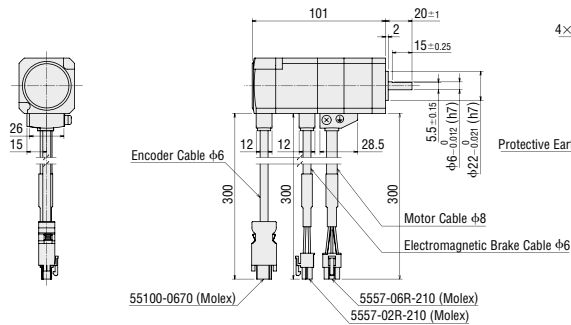

Straight

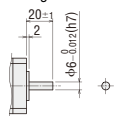

Frame Size 60 mm

Product Name	L	Mass [kg]
AZM66M □K	118	1.3
AZM69M □K	143.5	1.8

One Side Milled

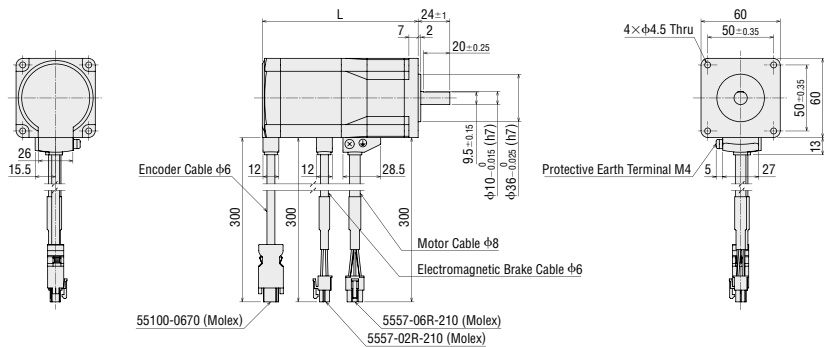

Straight

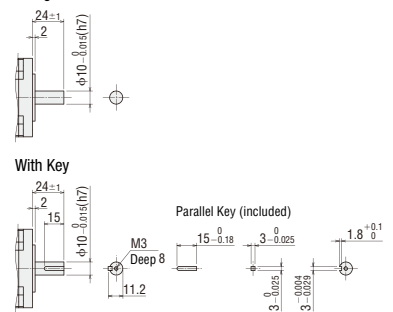

● Either 0 (straight) or 1 (with key) indicating the shaft shape is entered where the box □ is located within the product name. (For AZM46 straight only).

◇ **TS Gear**

Frame Size 42 mm

Product Name	Gear Ratio	Mass [kg]
AZM46AK-TS ◇	3.6, 7.2, 10, 20, 30	0.59

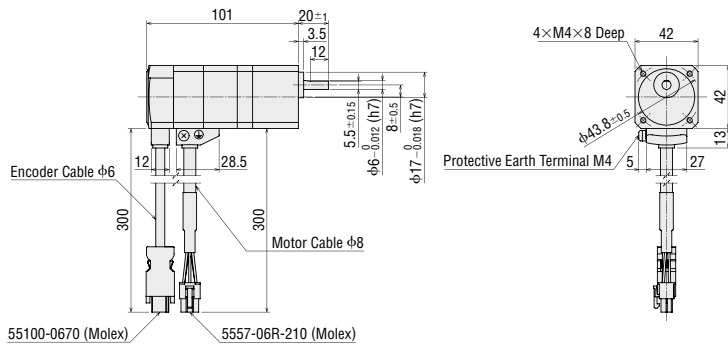

● Cable Direction

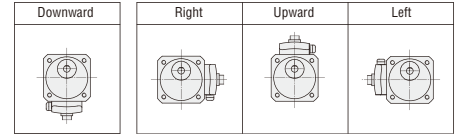

Frame Size 60 mm

Product Name	Gear Ratio	Mass [kg]
AZM66AK-TS ◇	3.6, 7.2, 10, 20, 30	1.3

● Installation screw: M4×60 P0.7 (4 screws included)

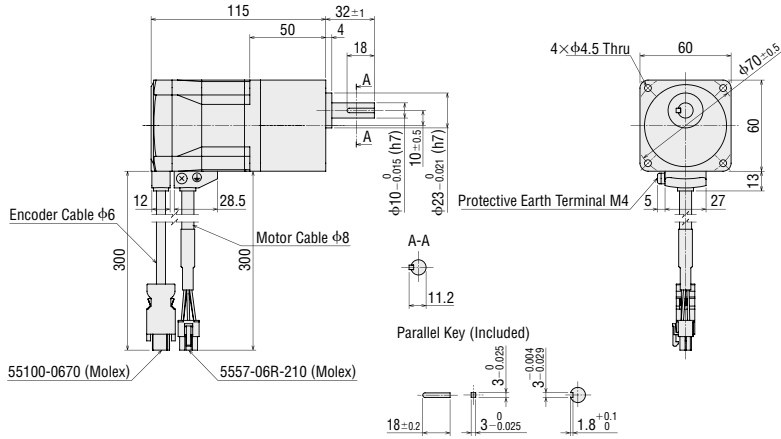

● Cable Direction

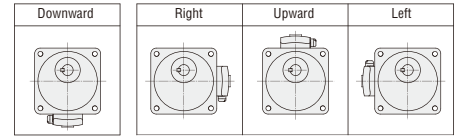

◇ **TS Geared Type with Electromagnetic Brake**

Frame Size 42 mm

Product Name	Gear Ratio	Mass [kg]
AZM46MK-TS ◇	3.6, 7.2, 10, 20, 30	0.76

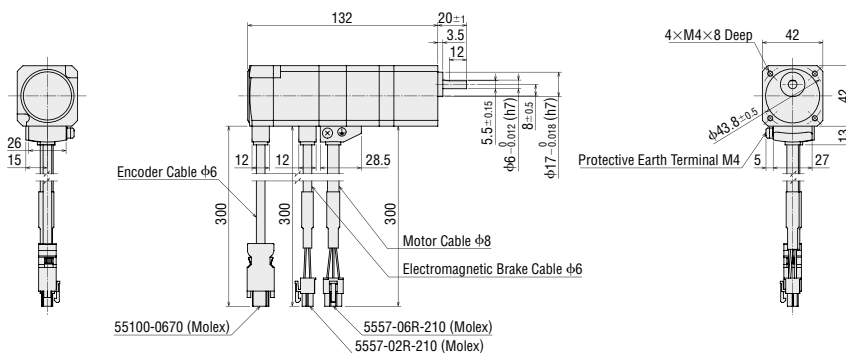

● Cable Direction

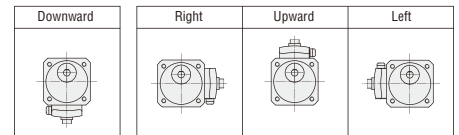

● The **■** within the product name includes a number expressing the gear ratio.

● Either **R** (right), **U** (up) or **L** (left) indicating the cable withdrawing direction is entered where the box **◇** is located within the product name. For downward direction no letter is entered in the box **◇**.

Frame Size 60 mm

Product Name	Gear Ratio	Mass [kg]
AZM66MK-TS ◇	3.6, 7.2, 10, 20, 30	1.7

● Installation screw: M4×60 P0.7 (4 screws included)

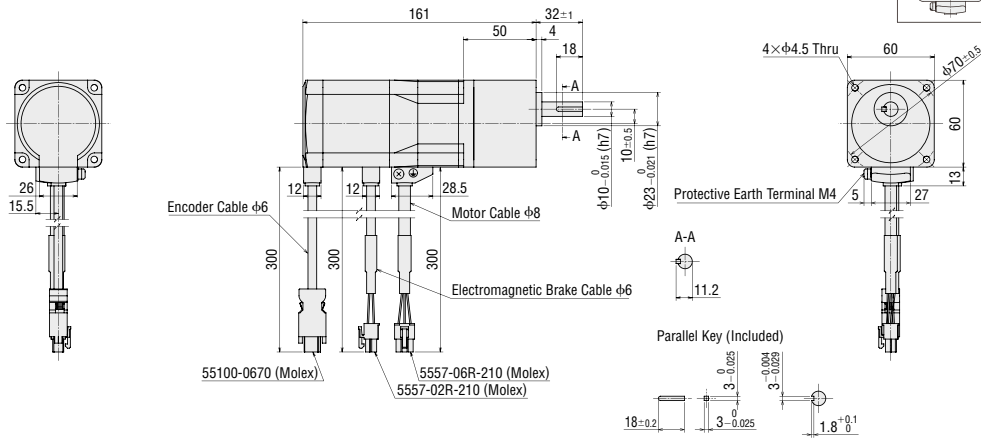

● Cable Direction

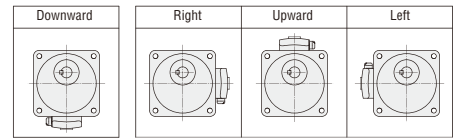

◇ FC Gear

Frame Size 42 mm Cable Withdrawing Direction Up

Product Name	Gear Ratio	Mass [kg]
AZM46AK-FC UA	7.2, 10, 20, 30	0.79

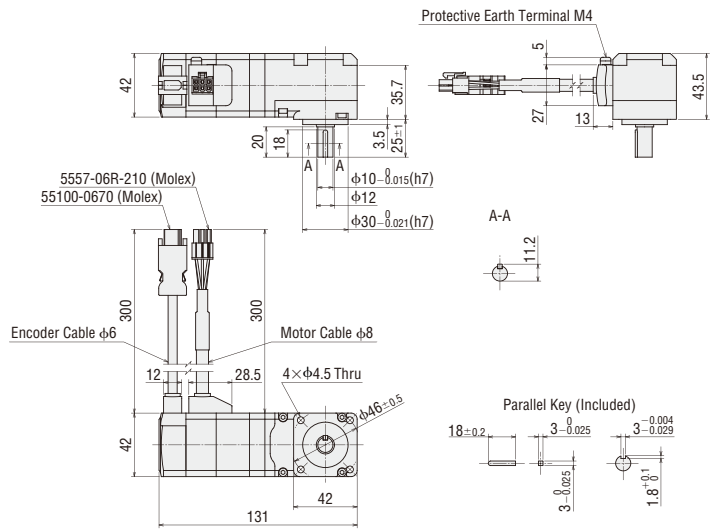

Frame Size 42 mm Cable Withdrawing Direction Down

Product Name	Gear Ratio	Mass [kg]
AZM46AK-FC DA	7.2, 10, 20, 30	0.79

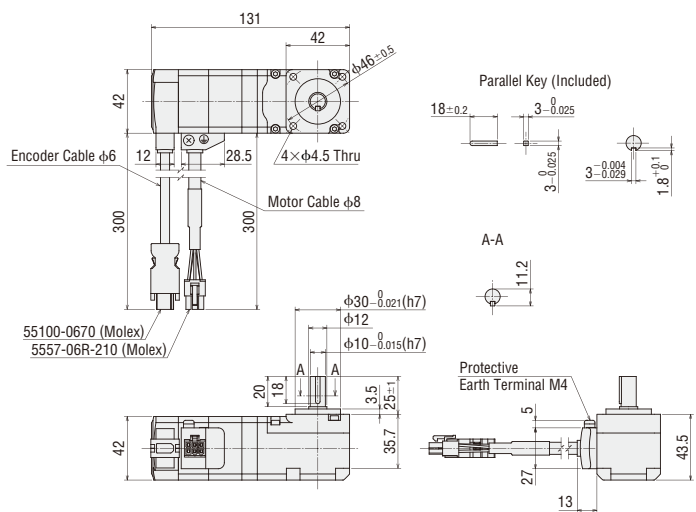

● The ■ within the product name includes a number expressing the gear ratio.

● Either **R** (right), **U** (up) or **L** (left) indicating the cable withdrawing direction is entered where the box ◇ is located within the product name. For downward direction no letter is entered in the box ◇

Features
System Configuration
Product Line
Specifications and Features
AC Input
Dimensions
Connection and Operation
System Configuration
Product Line
Specifications and Features
DC Input
Dimensions
Connection and Operation
Multiaxis Driver
Accessories

Frame Size 60 mm Cable Withdrawing Direction Up

Product Name	Gear Ratio	Mass [kg]
AZM66AK-FC ■ UA	7.2, 10, 20, 30	1.8

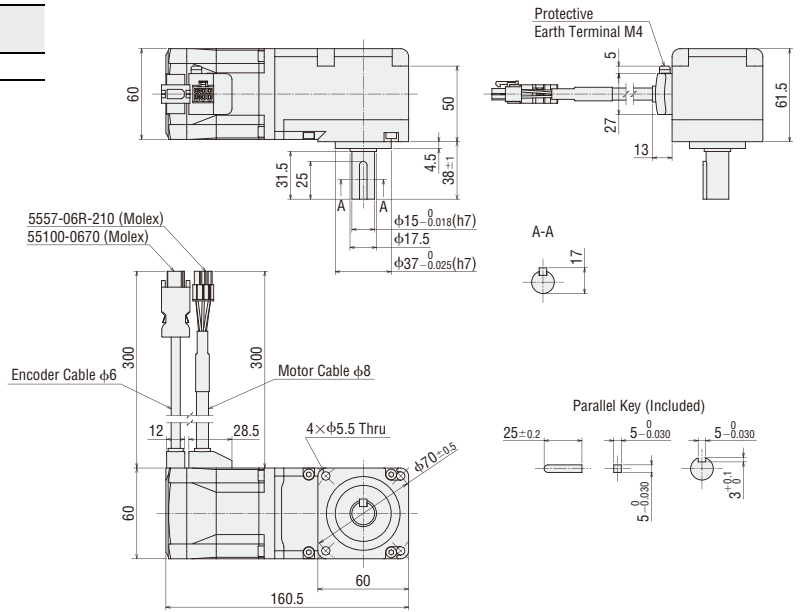

Frame Size 60 mm Cable Withdrawing Direction Down

Product Name	Gear Ratio	Mass [kg]
AZM66AK-FC ■ DA	7.2, 10, 20, 30	1.8

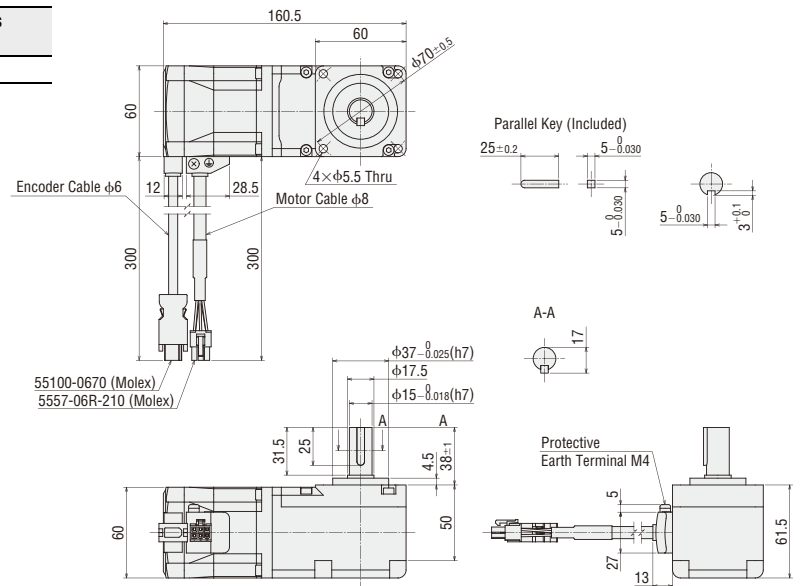

● The ■ within the product name includes a number expressing the gear ratio.

◇ FC Geared Type with Electromagnetic Brake
 Frame Size 42 mm Cable Withdrawing Direction Up

Product Name	Gear Ratio	Mass [kg]
AZM46MK-FC ■ UA	7.2, 10, 20, 30	0.96

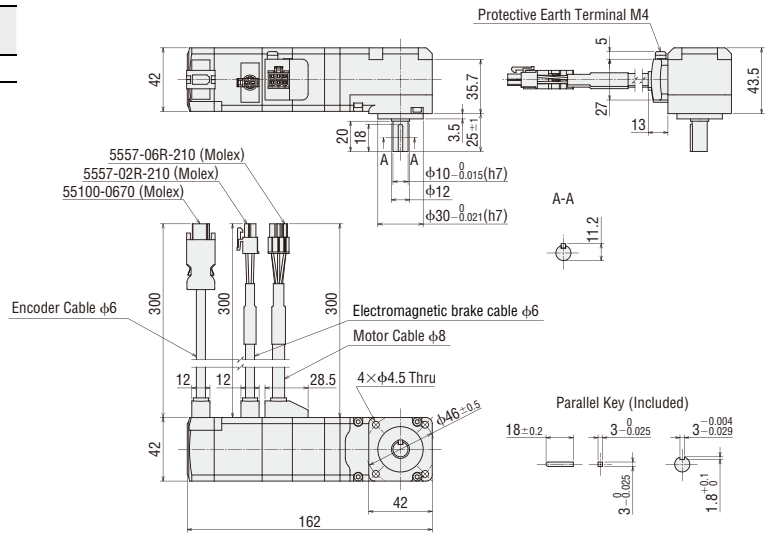

Frame Size 42 mm Cable Withdrawing Direction Down

Product Name	Gear Ratio	Mass [kg]
AZM46MK-FC ■ DA	7.2, 10, 20, 30	0.96

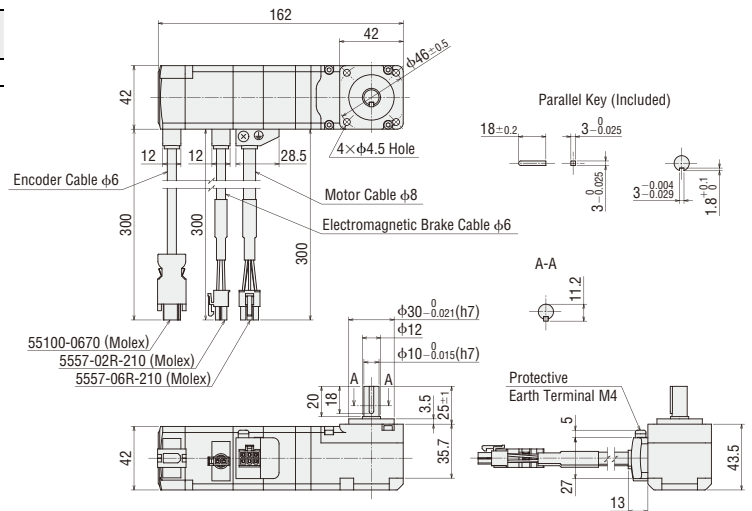

● The ■ within the product name includes a number expressing the gear ratio.

Features

System Configuration

Product Line

Specifications and Features

Dimensions

Connection and Operation

System Configuration

Product Line

Specifications and Features

Dimensions

Connection and Operation

Multiaxis Driver

Accessories

DC Input

AC Input

Frame Size 60 mm Cable Withdrawing Direction Up

Product Name	Gear Ratio	Mass [kg]
AZM66MK-FC UA	7.2, 10, 20, 30	2.2

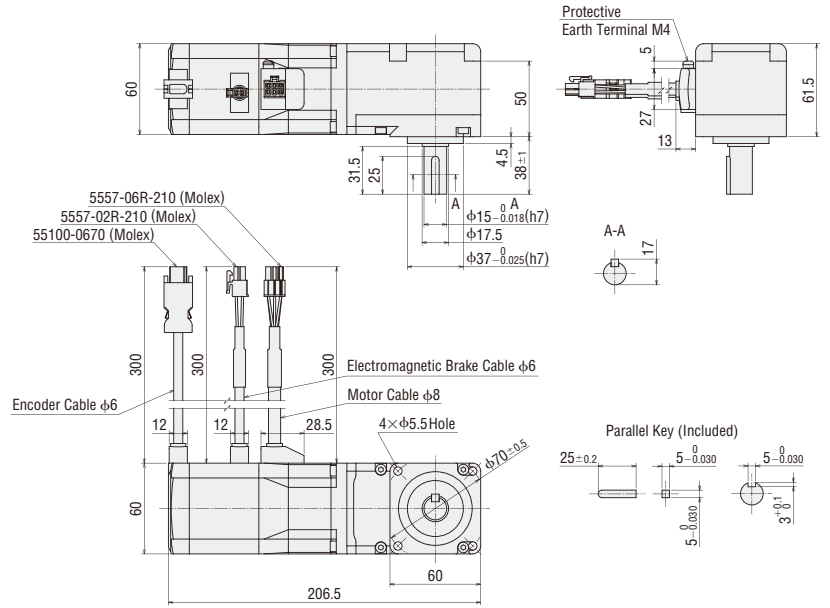

Frame Size 60 mm Cable Withdrawing Direction Down

Product Name	Gear Ratio	Mass [kg]
AZM66AK-MC DA	7.2, 10, 20, 30	2.2

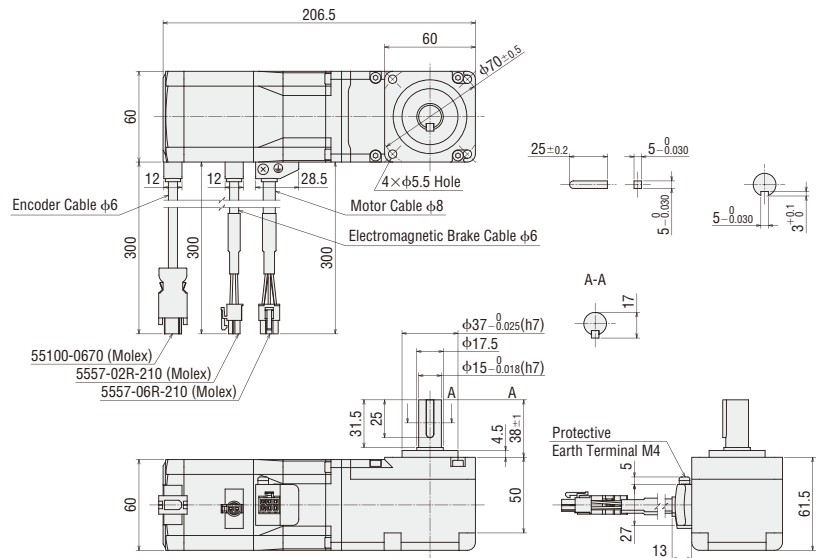

◆ PS Gear

Frame Size 42 mm

Product Name	Gear Ratio	L	Mass [kg]
AZM46AK-PS ■	5, 7.2, 10	98	0.64
	25, 36, 50	121.5	0.79

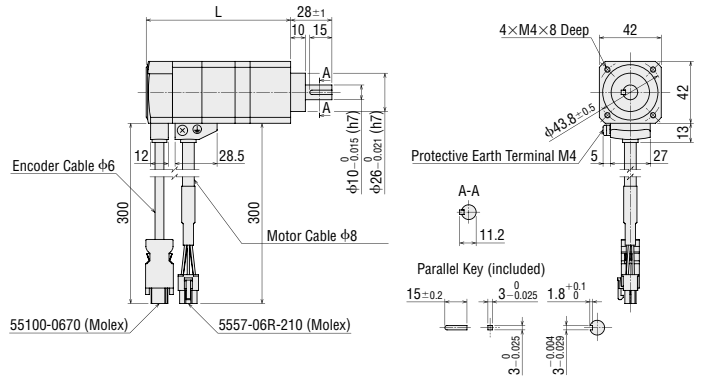

Frame Size 60 mm

Product Name	Gear Ratio	L	Mass [kg]
AZM66AK-PS ■	5, 7.2, 10	104	1.3
	25, 36, 50	124	1.6

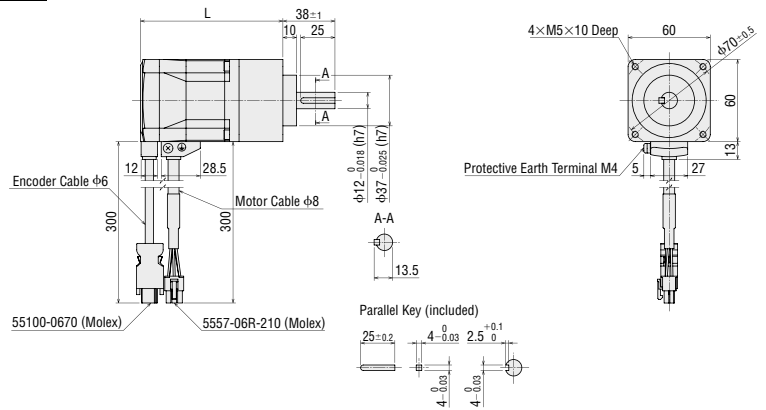

◆ PS Geared Type with Electromagnetic Brake

Frame Size 42 mm

Product Name	Gear Ratio	L	Mass [kg]
AZM46MK-PS ■	5, 7.2, 10	129	0.81
	25, 36, 50	152	0.96

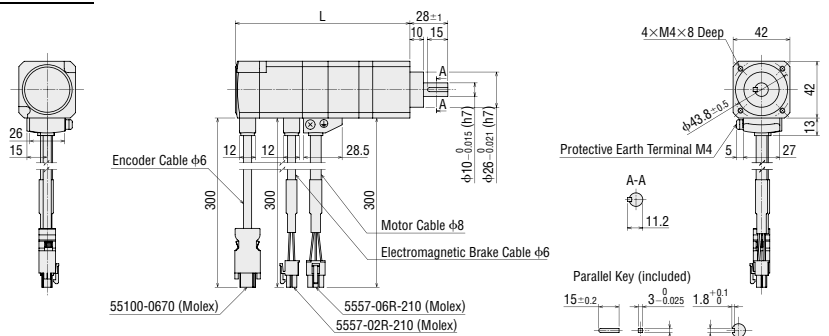

● The ■ within the product name includes a number expressing the gear ratio.

Frame Size 60 mm

Product Name	Gear Ratio	L	Mass [kg]
AZM66MK-PS 	5, 7, 2, 10	150	1.7
	25, 36, 50	170	2.0

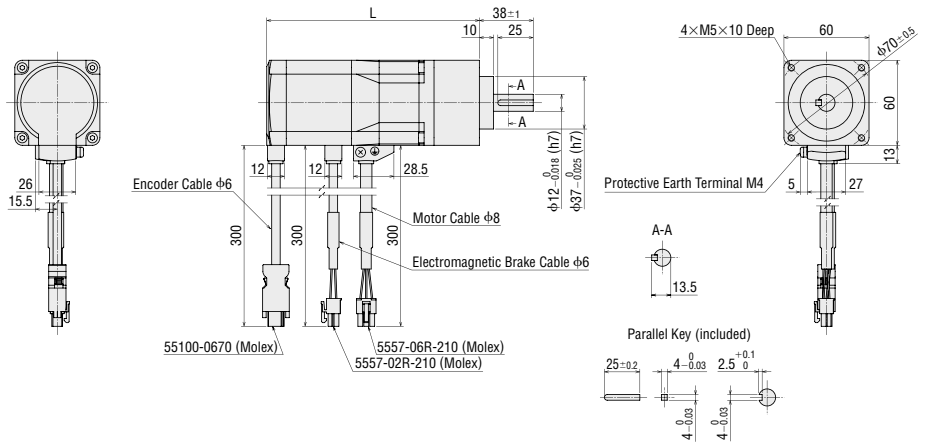

◇ HPG Geared Type Shaft Output Type

Frame Size 40 mm

Product Name	Gear Ratio	Mass [kg]
AZM46AK-HP 	5, 9	0.71

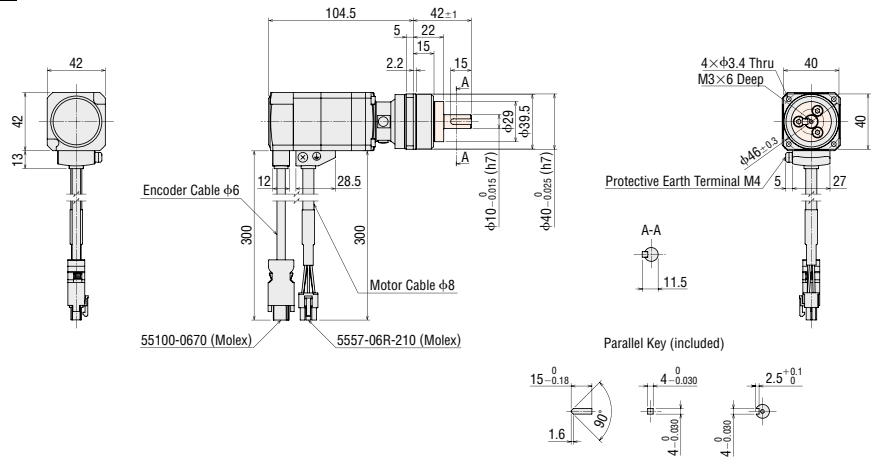

Frame Size 60 mm

Product Name	Gear Ratio	Mass [kg]
AZM66AK-HP 	5, 15	1.9

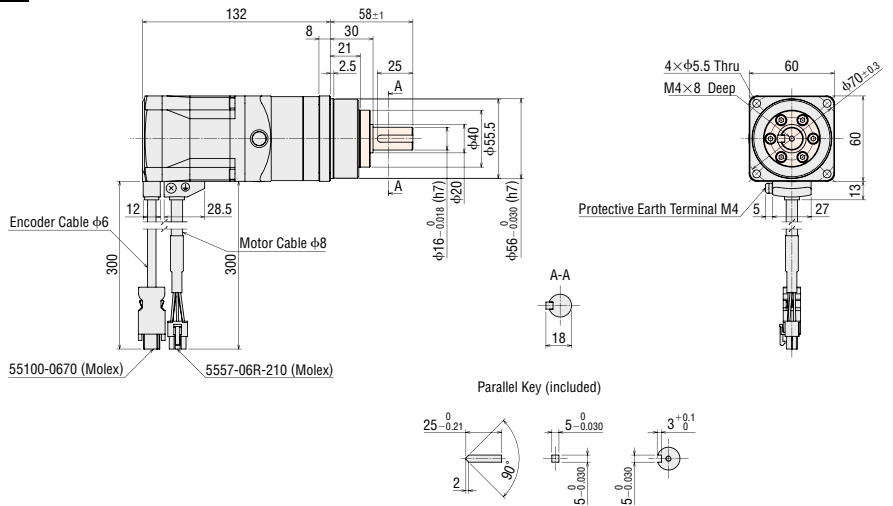

- The coloured part of the outline drawing is the rotation section.
- The within the product name includes a number expressing the gear ratio.

◆ HPG Geared Type Flange Output Type
Frame Size 40 mm

Product Name	Gear Ratio	Mass [kg]
AZM46AK-HP ■F	5, 9	0.66

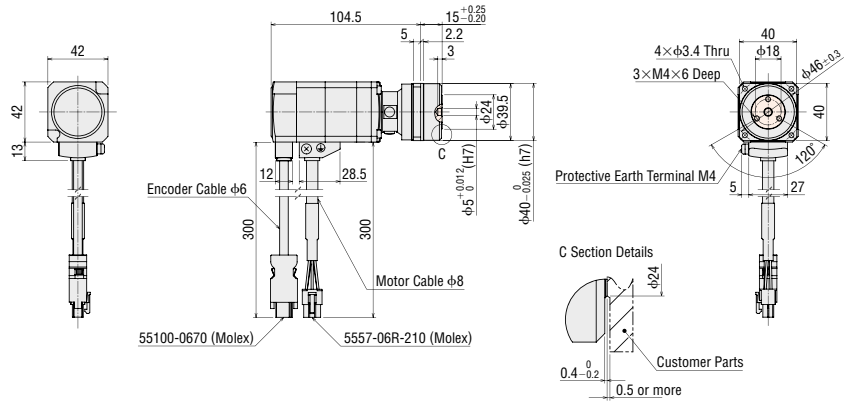

Frame Size 60 mm

Product Name	Gear Ratio	Mass [kg]
AZM66AK-HP ■F	5, 15	1.8

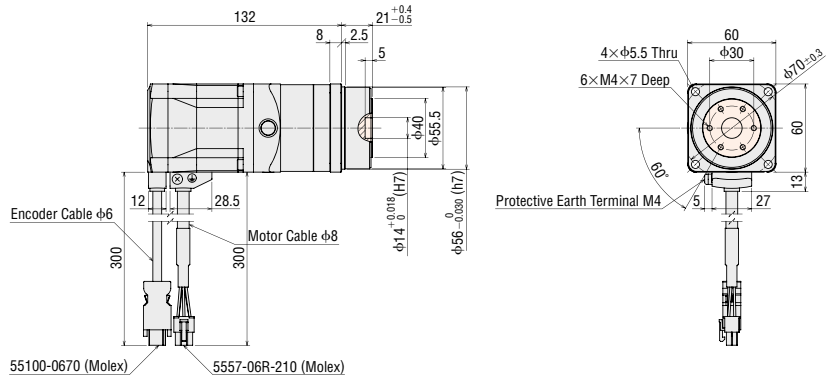

◆ HPG Geared Type with Electromagnetic Brake Shaft Output Type
Frame Size 40 mm

Product Name	Gear Ratio	Mass [kg]
AZM46MK-HP ■	5, 9	0.88

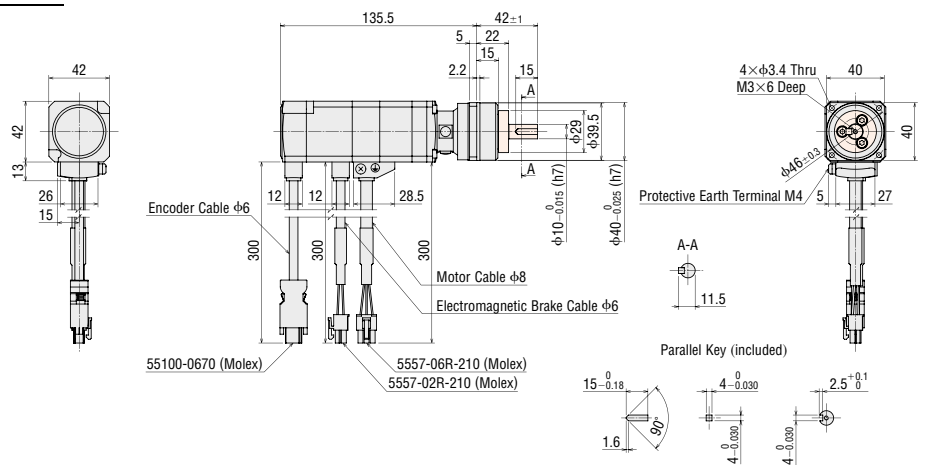

- The coloured part of the outline drawing is the rotation section.
- The within the product name includes a number expressing the gear ratio.

Frame Size 60 mm

Product Name	Gear Ratio	Mass [kg]
AZM66MK-HP ■	5, 15	2.3

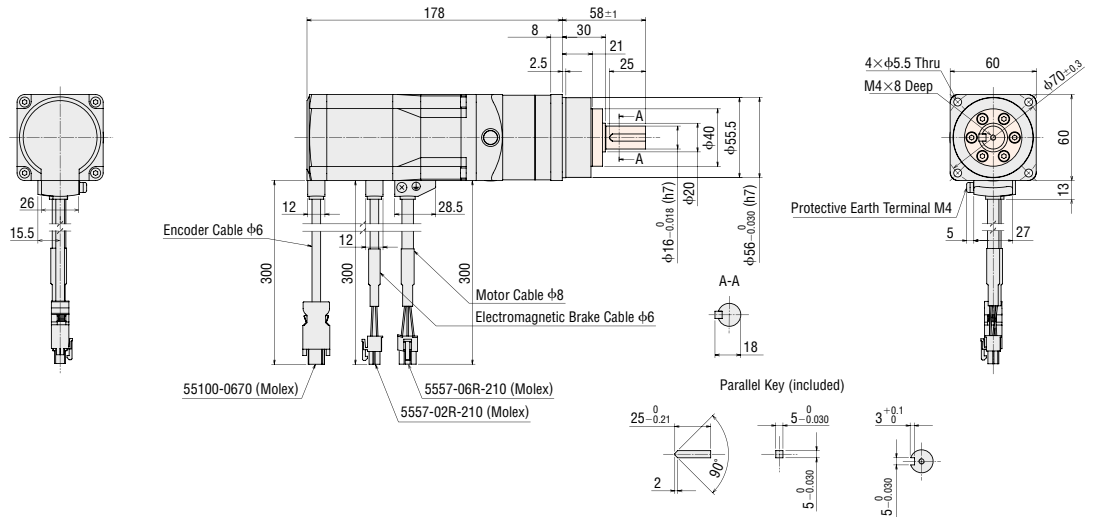

◆ **HPG** Geared Type with Electromagnetic Brake Flange Output Type
Frame Size 40 mm

Product Name	Gear Ratio	Mass [kg]
AZM46MK-HP ■F	5, 9	0.83

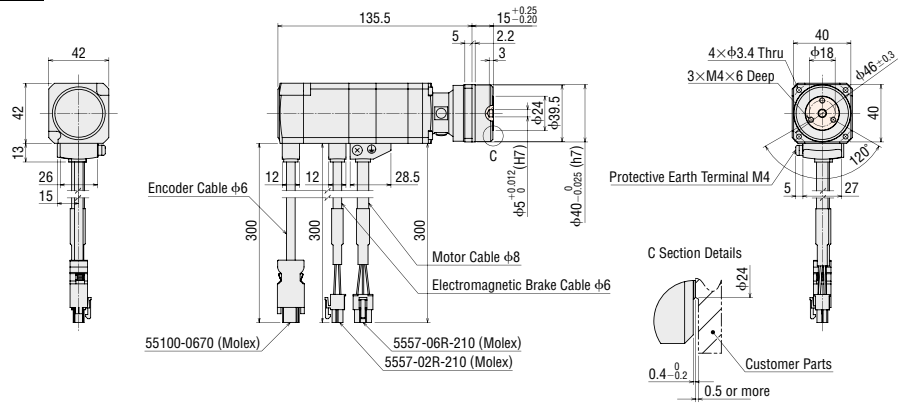

Frame Size 60 mm

Product Name	Gear Ratio	Mass [kg]
AZM66MK-HP ■F	5, 15	2.2

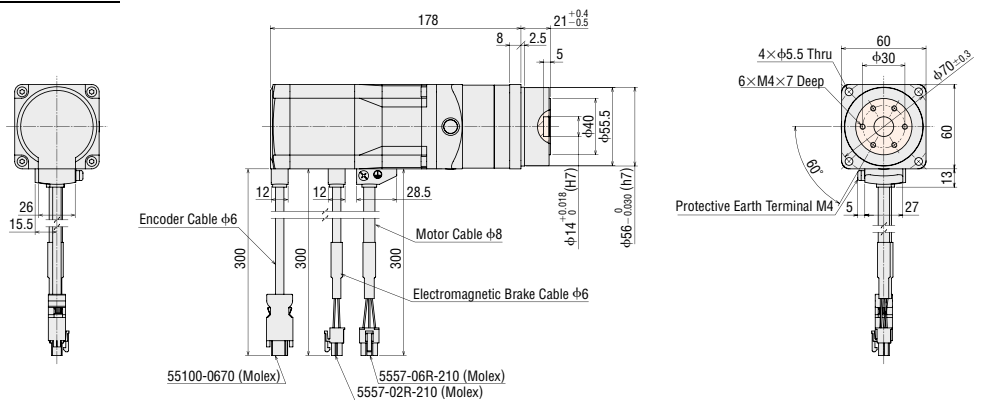

- The coloured part ■ of the outline drawing is the rotation section.
- The ■ within the product name includes a number expressing the gear ratio.

◇ Harmonic Gear

Frame Size 42 mm

Product Name	Gear Ratio	Mass [kg]
AZM46AK-HS 	50, 100	0.65

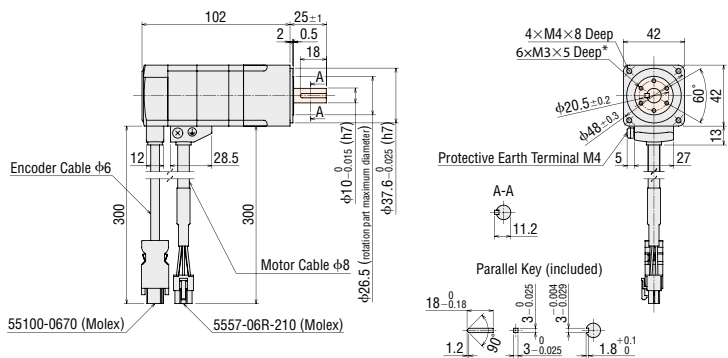

*The position of the output shaft relative to the screw holes on the rotating part cannot be specified. Adjust the position via the size of the screw holes on the load installation surface.

Frame Size 60 mm

Product Name	Gear Ratio	Mass [kg]
AZM66AK-HS 	50, 100	1.4

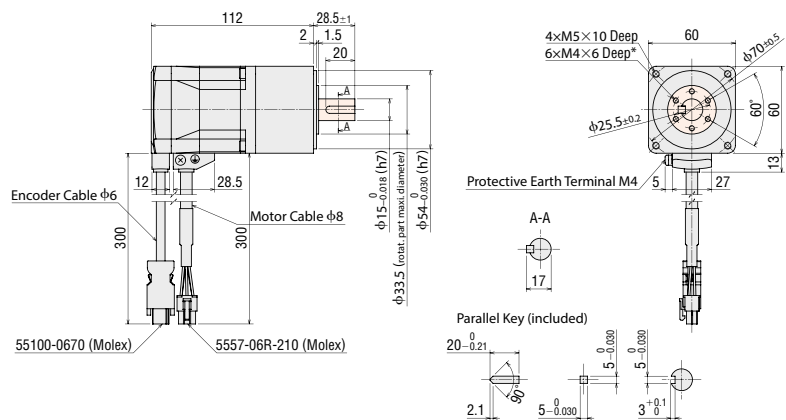

*The position of the output shaft relative to the screw holes on the rotating part cannot be specified. Adjust the position via the size of the screw holes on the load installation surface.

● The coloured part of the outline drawing is the rotation section.
 ● The within the product name includes a number expressing the gear ratio.

Features	System Configuration	Product Line	Specifications and Features	Dimensions	Connection and Operation	System Configuration	Product Line	Specifications and Features	Dimensions	Connection and Operation	Multiaxis Driver	Accessories
			AC Input					DC Input				

◇ Harmonic Geared Type with Electromagnetic Brake
Frame Size 42 mm

Product Name	Gear Ratio	Mass [kg]
AZM46MK-HS ■	50, 100	0.82

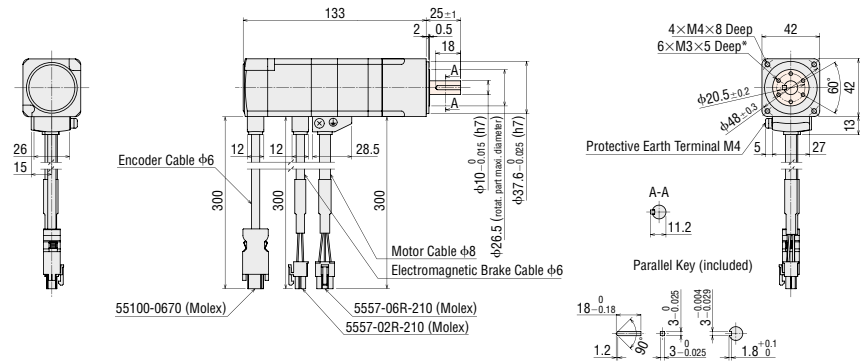

*The position of the output shaft relative to the screw holes on the rotating part cannot be specified. Adjust the position via the size of the screw holes on the load installation surface.

Frame Size 60 mm

Product Name	Gear Ratio	Mass [kg]
AZM66MK-HS ■	50, 100	1.8

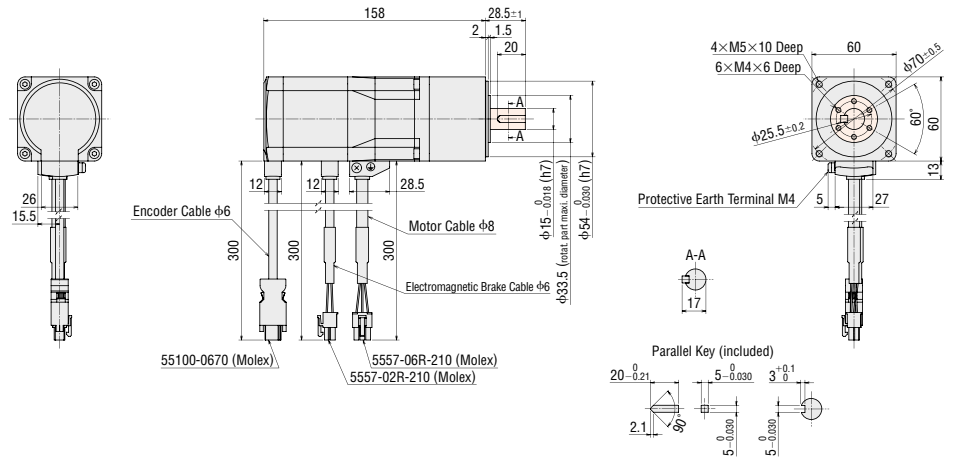

*The position of the output shaft relative to the screw holes on the rotating part cannot be specified. Adjust the position via the size of the screw holes on the load installation surface.

- The coloured part ■ of the outline drawing is the rotation section.
- The ■ within the product name includes a number expressing the gear ratio.

● Drivers

◇ Built-in Controller Type, Pulse-Input Type with RS-485 Communication

Driver Product Name: **AZD-KD, AZD-KX**

Mass: 0.15kg

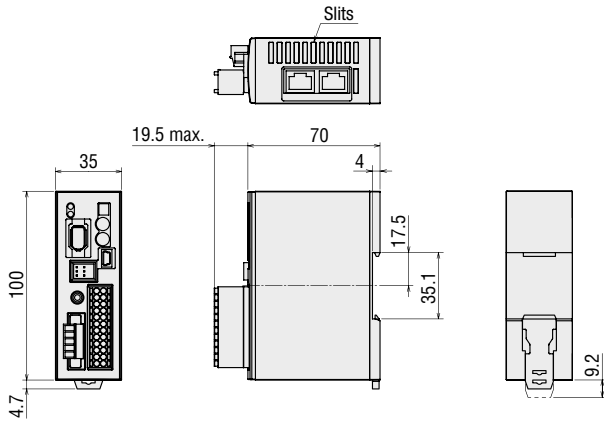

◇ Pulse-Input Type

Driver Product Name: **AZD-K**

Mass: 0.15kg

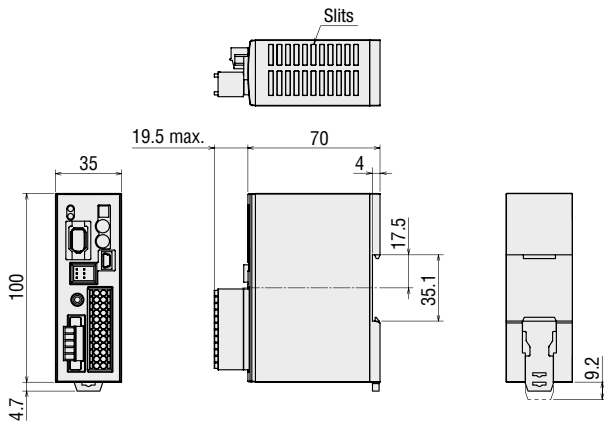

● Accessories

Connector form in power/electromagnetic brake connections (CN1)

Connector: MC1,5/5-STF-3,5
(PHOENIX CONTACT GmbH & Co. KG)

Connector for Input/Output Signal (CN4)

Connector: DFMC1,5/12-ST-3,5
(PHOENIX CONTACT GmbH & Co. KG)

● Accessories

Connector form in power/electromagnetic brake connections (CN1)

Connector: MC1,5/5-STF-3,5
(PHOENIX CONTACT GmbH & Co. KG)

Connector for Input/Output Signal (CN4)

Connector: DFMC1,5/12-ST-3,5
(PHOENIX CONTACT GmbH & Co. KG)

AC Input	Features
	System Configuration
	Product Line
	Specifications and Features
DC Input	Dimensions
	Connection and Operation
	System Configuration
	Product Line
Multiaxis Driver	Specifications and Features
	Dimensions
	Connection and Operation
	Accessories

● Connection Cable Sets / Flexible Connection Cable Sets

[AZ14, AZ15, AZ24, AZ26 use]

◇ Connection Cable for Motor

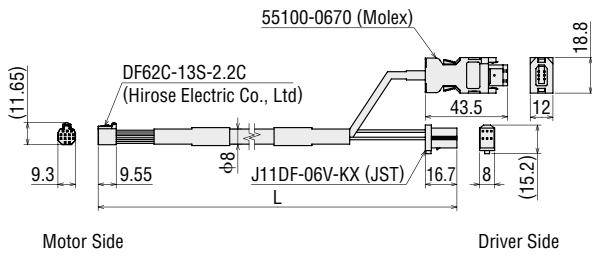

[AZ46, AZ48, AZ66, AZ69 use]

◇ Connection Cable for Motor

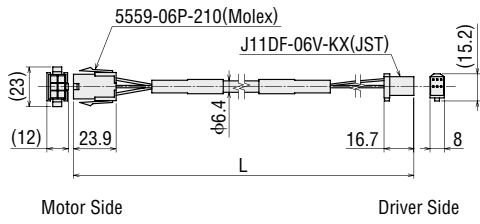

◇ Connection Cable for Encoder

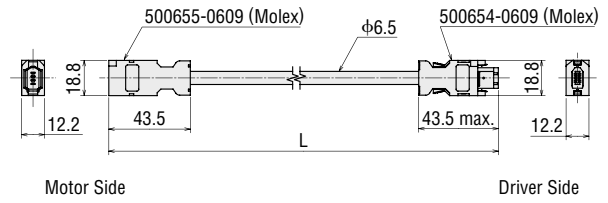

◇ Connection Cable for Electromagnetic Brake
(Only for electromagnetic brake products)

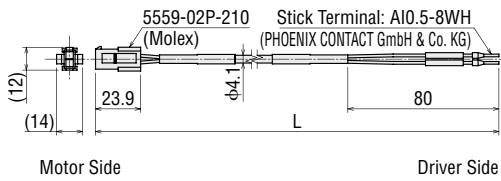

*The length L (m) is specified where L is located in the dimensions in "Product Line" on page 71.

Notes

- The motor cable and electromagnetic brake cable from the motor cannot be connected directly to the driver. When connecting to a driver, use the connection cable.

Connection and Operation (Built-in Controller Type)

Name and Functions of Driver Parts

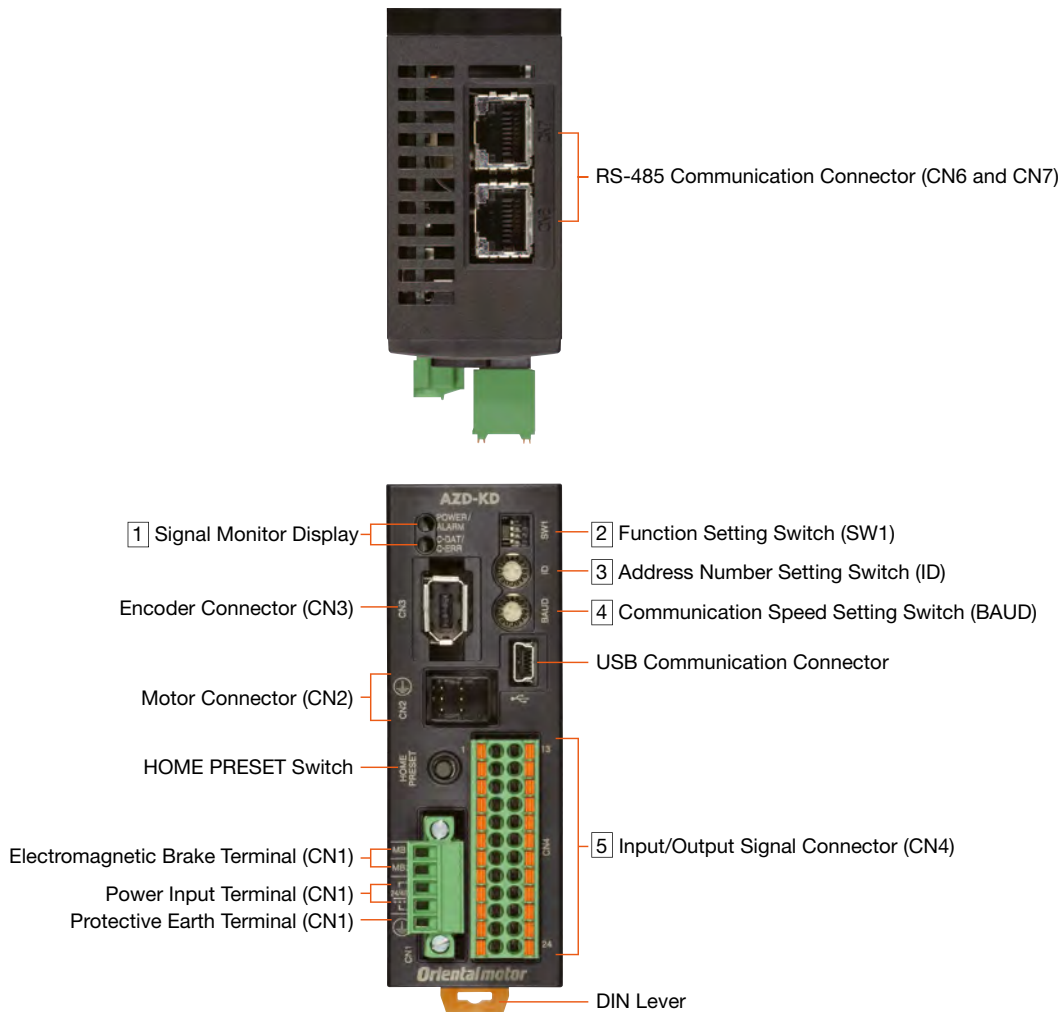

1 Signal Monitor Display

◇ LED Display

Display	Colour	Function	When Activated
POWER	Green	Power Display	When power is on.
ALARM	Red	Alarm Display	Blinks when protective functions are activated.
C-DAT	Green	Communication Display	When communication data is received or sent.
C-ERR	Red	Communication Error Display	When there is an error with communication data.

2 Function Setting Switch

Display	No.	Function
SW1	1	This sets the address number in combination with the address number setting switch (ID) (Factory Setting: OFF).
	2	Set the RS-485 communication protocol. Factory setting: Built-in Controller Type: OFF Pulse-Input Type with RS-485 Communication: ON
	3	Set the RS-485 communication terminal resistor (120 Ω) (Factory Setting: OFF).
	4	OFF: no terminal resistor, ON: terminal resistor connected.

*Please use the same settings for both No. 3 and No. 4.

3 Address Number Setting Switch (ID)

Display	Function
ID	Set this when RS-485 communication is used. Set the axis number. Factory setting: Built-in Controller Type: 0 Pulse-Input Type with RS-485 Communication: 1

4 Communication Speed Setting Switch

Display	Function
BAUD	Set this when RS-485 communication is used. Set the baud rate. Factory setting: Built-in Controller Type: 7 Pulse Input Type with RS-485 Communication: 4

◇ Settings of the RS-485 Communication Speed

No.	Baud Rate (bps)
0	9600
1	19200
2	38400
3	57600
4	115200
5	230400
6	Not used
7	Network Converter
8-F	Not used

5 Input/Output Signal Connector (CN4)

For the Pulse-Input Type with RS-485 Communication pin No. 1, 2, 13 and 14 are for pulse input. For connecting to a programmable controller refer to page 108-109 of the Pulse-Input Type.

Display	Pin Number	Driver Type	Signal Name	Content	
CN4	1	Built-In Controller Type	IN0	START	This signal is used to start positioning operation.
		Pulse-Input Type with RS-485 Communication	CW+* [PLS+]	CW Pulse Input+ [Pulse Input+]	Pulse signal for motor operation in CW direction with 2 pulse input method. The brackets [] show the content when using 1 pulse input method.
	2	Built-In Controller Type	IN2	M1	Use 3 bits (M0, M1 and M2) to select the operating data number.
		Pulse-Input Type with RS-485 Communication	CCW+* [DIR+]	CCW Pulse Input+ [Rotation Direction Input+]	Pulse signal for motor operation in CCW direction with 2 pulse input method. The brackets [] show the content when using 1 pulse input method.
	3	Common	IN4	ZHOME	Move to the home position set by the HOME PRESET switch.
	4	Common	IN6	STOP	Stop the motor.
	5	Common	IN-COM [0-7]*	IN0-IN7 Input Common	
	6	Common	IN8	FW-JOG	Start the JOG operation.
	7	Common	OUT0	HOME-END	Output when the home position is fixed and the high speed return-to-home operation is complete.
	8	Common	OUT2	PLS-RDY	Not used.
	9	Common	OUT4	MOVE	Output when the motor is operating.
	10	Common	OUT-COM*	Output Common	
	11	Common	ASG+	A-Phase Output+	
	12	Common	BSG+	B-Phase Output+	
	13	Built-In Controller Type	IN1	M0	Use 3 bits (M0, M1 and M2) to select the operating data number.
		Pulse-Input Type with RS-485 Communication	CW-* [PLS-]	CW Pulse Input- [Pulse Input-]	Pulse signal for motor operation in CW direction with 2 pulse input method. The brackets [] show the content when using 1 pulse input method.
	14	Built-In Controller Type	IN3	M2	Use 3 bits (M0, M1 and M2) to select the operating data number.
		Pulse-Input Type with RS-485 Communication	CCW-* [DIR-]	CCW Pulse Input+ [Rotation Direction Input+]	Pulse signal for motor operation in CCW direction with 2 pulse input method. The brackets [] show the content when using 1 pulse input method.
	15	Common	IN5	FREE	Stop motor excitation.
	16	Common	IN7	ALM-RST	Reset the alarm.
	17	Common	IN-COM [8-9]*	IN8, IN9 Input Common	
	18	Common	IN9	RV-JOG	Start the JOG operation.
	19	Common	OUT1	IN-POS	Output when the motor operation is complete.
	20	Common	OUT3	READY	Output when the driver is prepared for operation.
21	Common	OUT5	ALM-B	Outputs the alarm status for the driver (normally closed).	
22	Common	GND*1	Ground		
23	Common	ASG-	A-Phase Output-		
24	Common	BSG-	B-Phase Output-		

● Functions to assign can be set by specifying parameters. Initial values are shown above. Refer to the AZ Series Function Edition operating manual.

*1 The initial value setting cannot be changed.

● Connection Diagram

◇ Connection to Peripheral Equipment

■ AZ Series
 □ This is available as an option (sold separately).

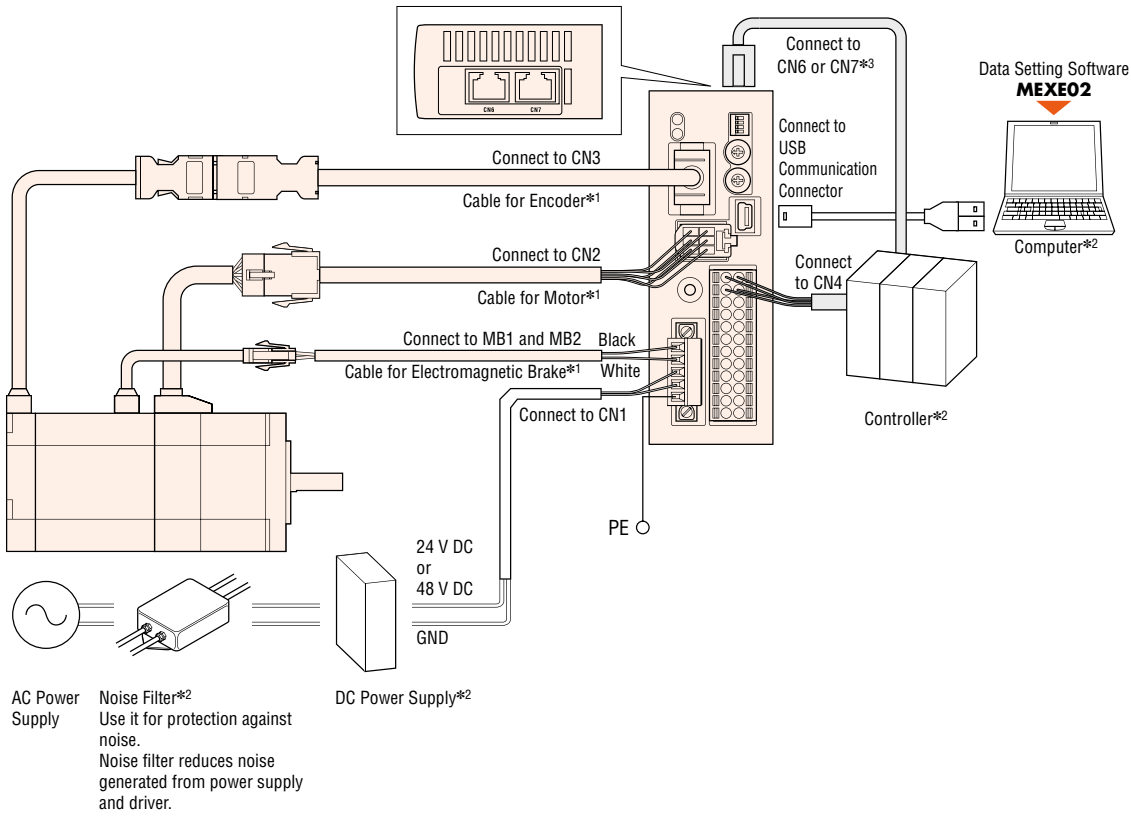

- *1 When wiring the motor and the driver, keep a max. distance of 20 m.
- *2 Prepared by the customer.
- *3 When controlling with RS-485 communications, connect to the controller.

◇ USB Cable Connection

The computer on which the data setting software **MEXE02** is installed and driver are connected with a USB cable. Use the following specifications for the USB cable.

Specification	USB 2.0 (full speed)
Cable	Length: 3 m (or less)
	Format: A-mini-B

Features
System Configuration
Product Line
Specifications and Features
Dimensions
Connection and Operation
System Configuration
Product Line
Specifications and Features
Dimensions
Connection and Operation
Multiaxis Driver
Accessories

◇ Connecting to a Host Controller

● Connecting to a Current Sink Output Circuit

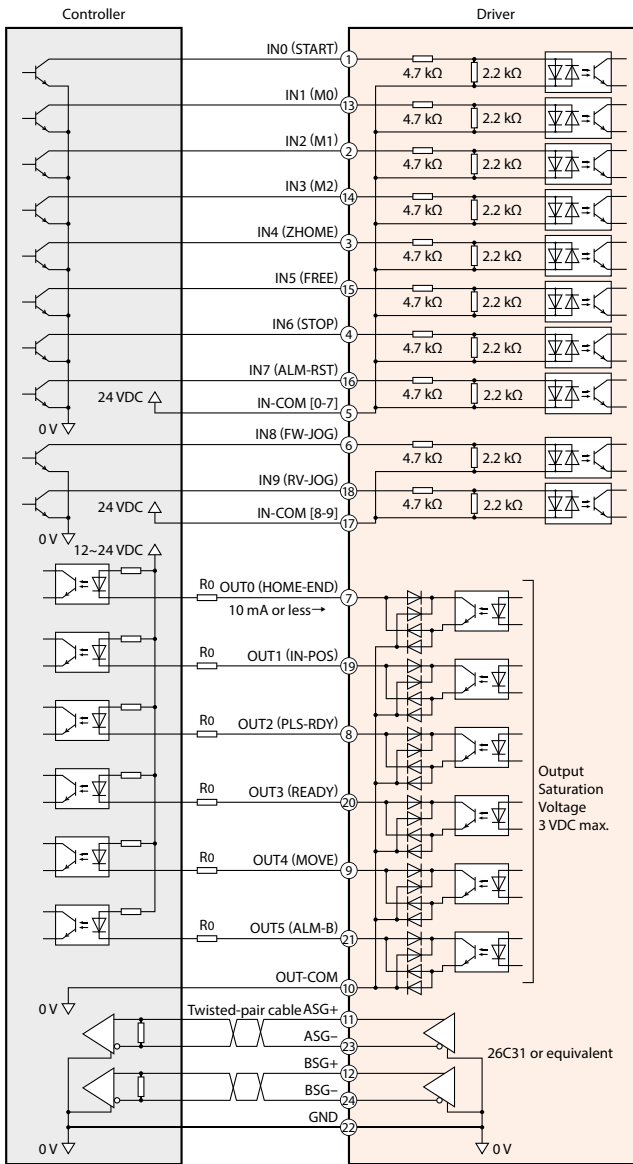

Notes

- Use 24 VDC for the input signals.
- Use output signal at 12~24 VDC 10 mA or less. When the current value exceeds 10 mA, connect an external resistor R_o to reduce the current to 10 mA or less.
- Make sure the signal line is wired at a distance of 200 mm or longer from the power lines (power supply line and motor line). Furthermore, do not insert the signal line in the same pipe as the power lines or bundle them together.
- When noise is emitted from the motor cable or power cable due to wiring or allocation and it cause a problem, shield the cable or use ferrite cores.

● Connecting to a Current Source Output Circuit

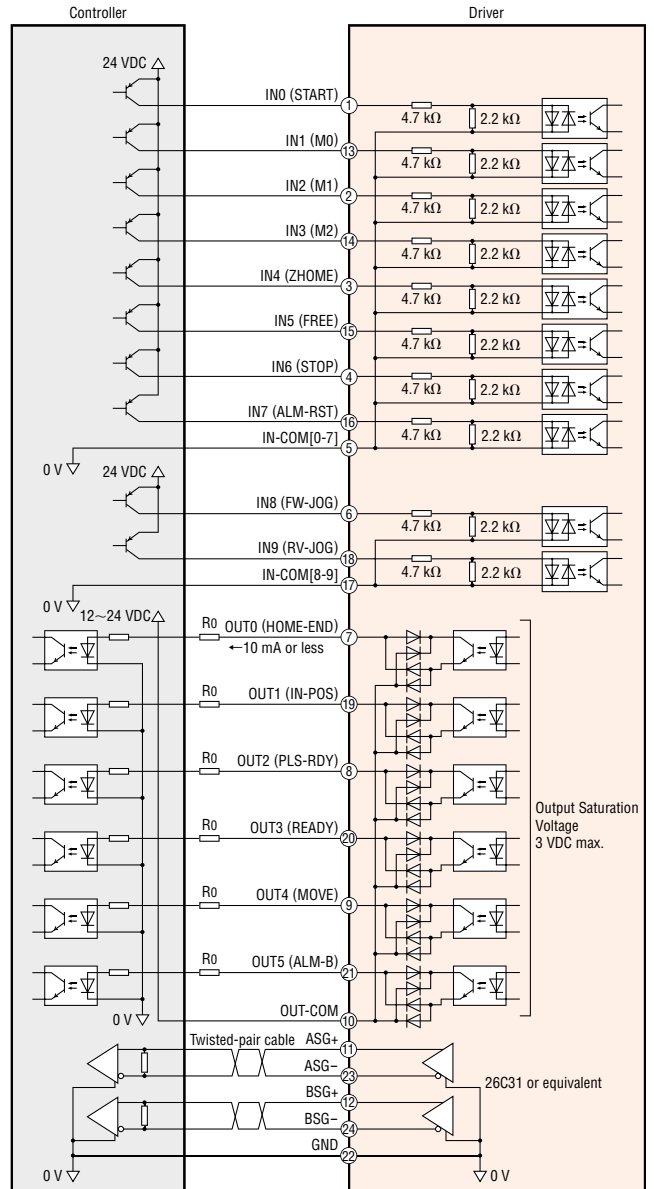

Notes

- Use 24 VDC for the input signals.
- Use output signal at 12~24 VDC 10 mA or less. When the current value exceeds 10 mA, connect an external resistor R_o to reduce the current to 10 mA or less.
- Make sure the signal line is wired at a distance of 200 mm or longer from the power line (power supply line and motor line). Furthermore, do not insert the signal line in the same pipe as the power lines or bundle them together.
- When noise is emitted from the motor cable or power cable due to wiring or allocation and it cause a problem, shield the cable or use ferrite cores.

◇ Connecting to a Programmable Controller (Pulse-Input Type with RS-485 Communication)

The connection is the same as that of the Pulse-Input Type. See page 108-109

Connection and Operation (Pulse-Input Type)

Names and Functions of Driver Parts

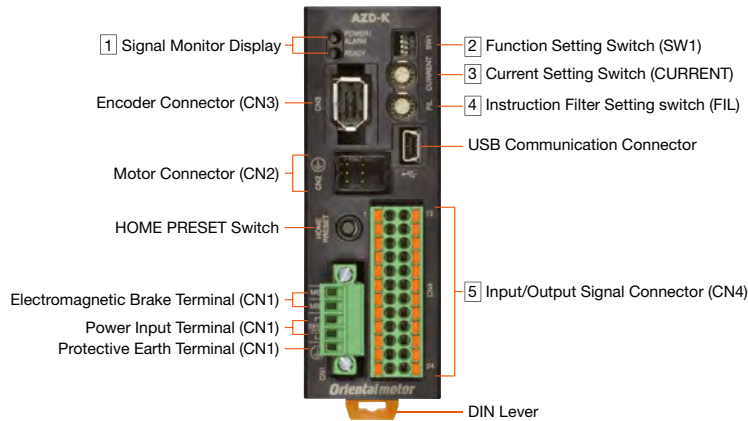

1 Signal Monitor Display

◇ LED Display

Display	Colour	Function	When Activated
POWER	Green	Power Display	When power is on.
ALARM	Red	Alarm Display	Blinks when protective functions are activated.
READY	Green	READY output	When READY output is set to ON

2 Function Setting Switch

Display	No.	Function
SW1	1	Set the resolution for each motor output axis rotation (Factory Setting : OFF [1000p/r]).
	2	Set the pulse input format to 1 pulse input mode or 2 pulse input mode. (Factory setting: ON [1-pulse input mode])
	3, 4	Not used

3 Current Setting Switch

Display	Function
CURRENT	Set basic current that is the base for the operation current and stop current (Factory Setting: F).

4 Command Filter Setting Switch

Display	Function
FIL	Adjust the responsiveness of the motor (Factory Setting: 1).

5 Input/Output Signal Connector (CN4)

Display	Pin Number	Signal Name	Content
CN5	1	CW+[PLS+]*1	CW pulse input+[pulse input+] Pulse signal for motor operation in CW direction with 2 pulse input method. The brackets [] show the content when using 1 pulse input method.
	2	CCW+[DIR+]*1	CCW pulse input+[rotation direction input+] Pulse signal for motor operation in CCW direction with 2 pulse input method. The brackets [] show the content when using 1 pulse input method.
	3	IN4	ZHOME Move to the home position set with the HOME PRESET switch.
	4	IN6	STOP Stop the motor.
	5	IN-COM [4-7]*1	IN4-IN7 input common
	6	IN8	FW-JOG Start JOG operation.
	7	OUT0	HOME-END Output when determining the home position or completing high speed return-to-home operation.
	8	OUT2	PLS-RDY Output when the pulse input preparation is complete.
	9	OUT4	MOVE Output while operating the motor.
	10	OUT-COM*1	Output common
	11	ASG+	A phase pulse output+
	12	BSG+	B phase pulse output+
	13	CW-[PLS-]*1	CW pulse input-[pulse input-] Pulse signal for motor operation in CW direction with 2 pulse input method. The brackets [] show the content when using 1 pulse input method.
	14	CCW-[DIR-]*1	CCW pulse input-[rotation direction input -] Pulse signal for motor operation in CCW direction with 2 pulse input method. The brackets [] show the content when using 1 pulse input method.
	15	IN5	FREE The motor is set to non-excitation.
	16	IN7	ALM-RST Reset the alarm.
	17	IN-COM [8-9]*1	IN8, IN9 input common
	18	IN9	RV-JOG Start JOG operation.
	19	OUT1	IN-POS Output when the motor operation is complete.
	20	OUT3	READY Outputs when the driver is ready for operation.
	21	OUT5	ALM-B Output the driver alarm state (normal close).
	22	GND*1	Ground
	23	ASG-	A phase pulse output-
	24	BSG-	B phase pulse output-

Assigned functions are set by means of the parameter settings. The above is the initial value. For details, refer to the User's Manual.

*1 The initial value setting cannot be changed.

Features
System Configuration
Product Line
Specifications and Features
AC Input
Dimensions
Connection and Operation
System Configuration
Product Line
Specifications and Features
DC Input
Dimensions
Connection and Operation
MultiAxis Driver
Accessories

● Connection Diagram

◇ Connection to Peripheral Equipment

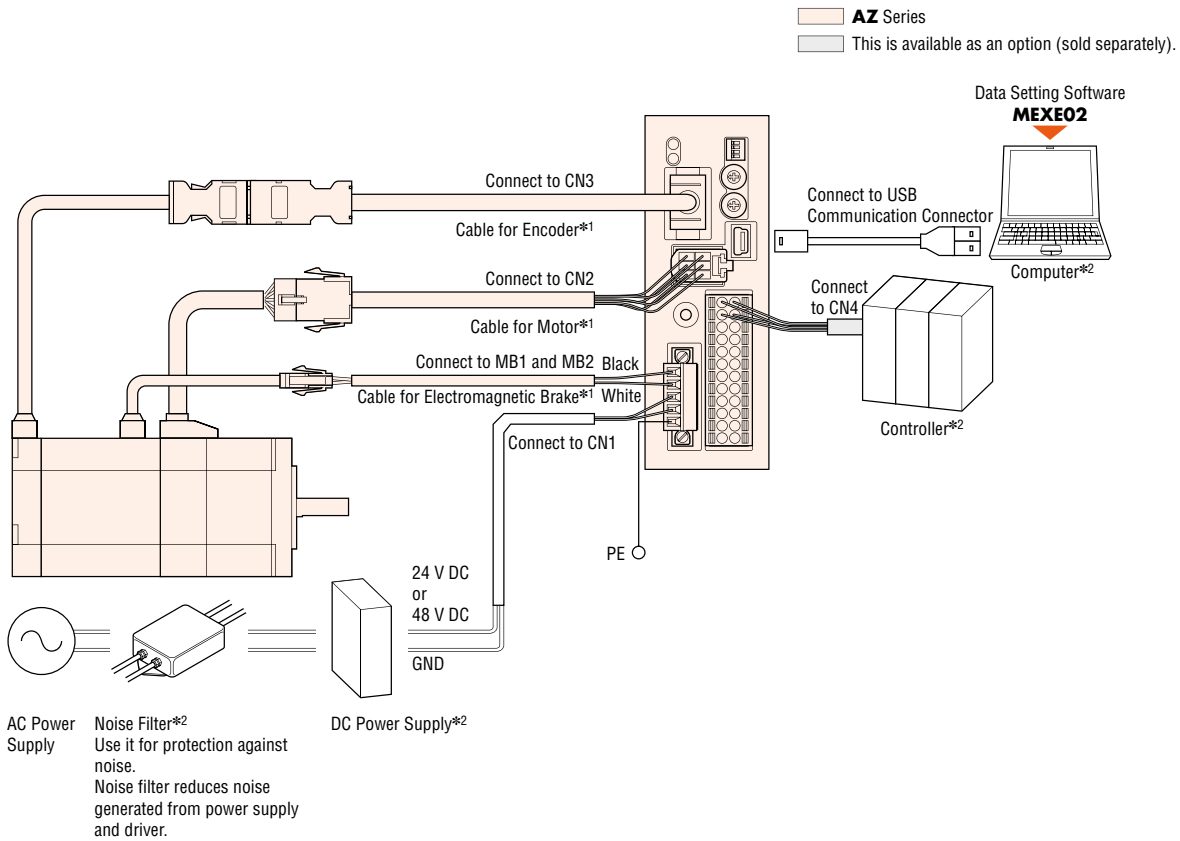

*1 Please keep the extension between the motor and driver up to 20m

*2 Prepared by the customer.

◇ USB Cable Connection

The computer on which the data setting software **MEXE02** is installed and driver are connected with a USB cable. Use the following specifications for the USB cable.

Specification	USB 2.0 (full speed)
Cable	Length: 3 m (or less)
	Format: A-mini-B

◇ Connecting to a Host Controller

● Connecting to a Current Sink Output Circuit

When the pulse input is a line driver

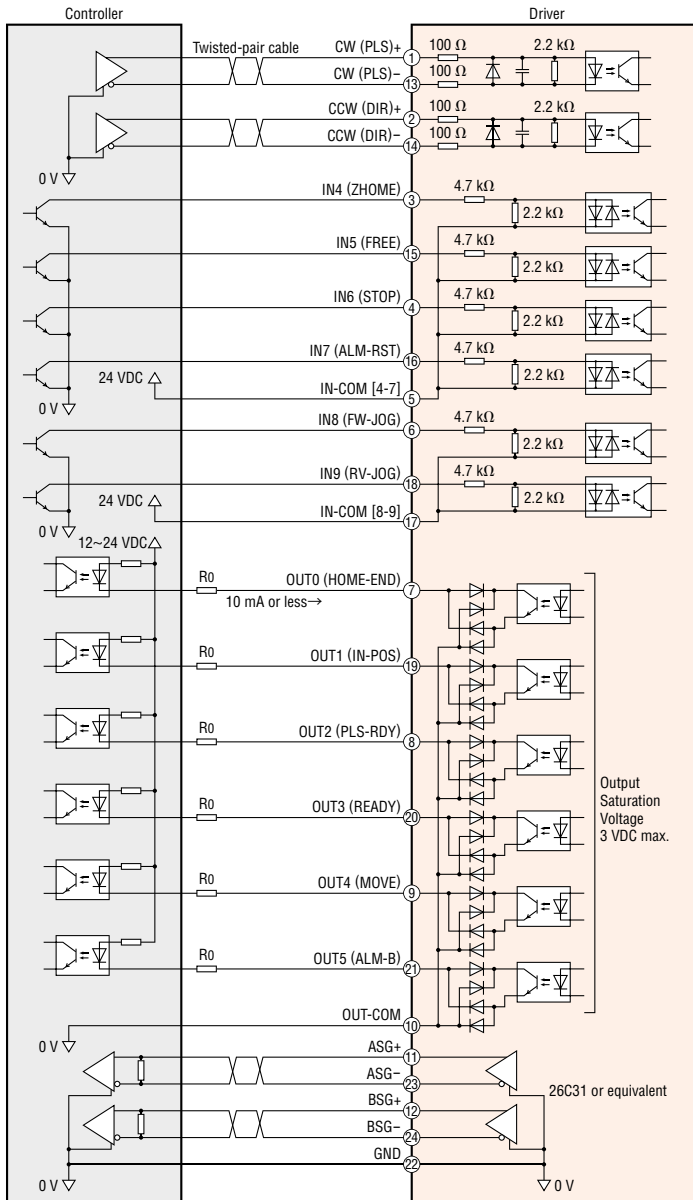

Notes

- Use 24 VDC for the input signals.
- Use output signal at 12~24 VDC 10 mA or less. When the current value exceeds 10 mA, connect an external resistor R_0 to reduce the current to 10 mA or less.
- Make sure the signal line is wired at a distance of 200 mm or longer from the power line (power supply line and motor line). Furthermore, do not insert the signal line in the same pipe as the power lines or bundle them together.
- When noise is emitted from the motor cable or power cable due to wiring or allocation and it cause a problem, shield the cable or use ferrite cores.

When the pulse input is an open collector

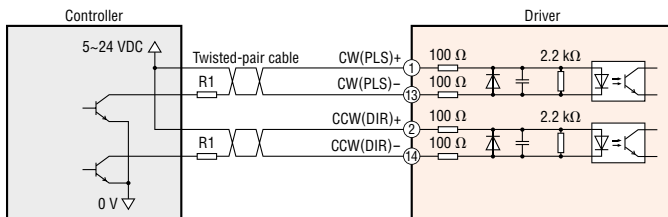

Notes

- For CW (PLS) input and CCW (DIR) input, use 5-24 VDC. Where the voltage exceeds 5 VDC, connect an external resistor R_1 to adjust the input current to be 7-20mA.

Features
System Configuration
Product Line
Specifications and Features
AC Input
Dimensions
Connection and Operation
System Configuration
Product Line
Specifications and Features
DC Input
Dimensions
Connection and Operation
Multiaxis Driver
Accessories

◇ Connecting to a Host Controller

● Connecting to a Current Source Output Circuit

When the pulse input is a line driver

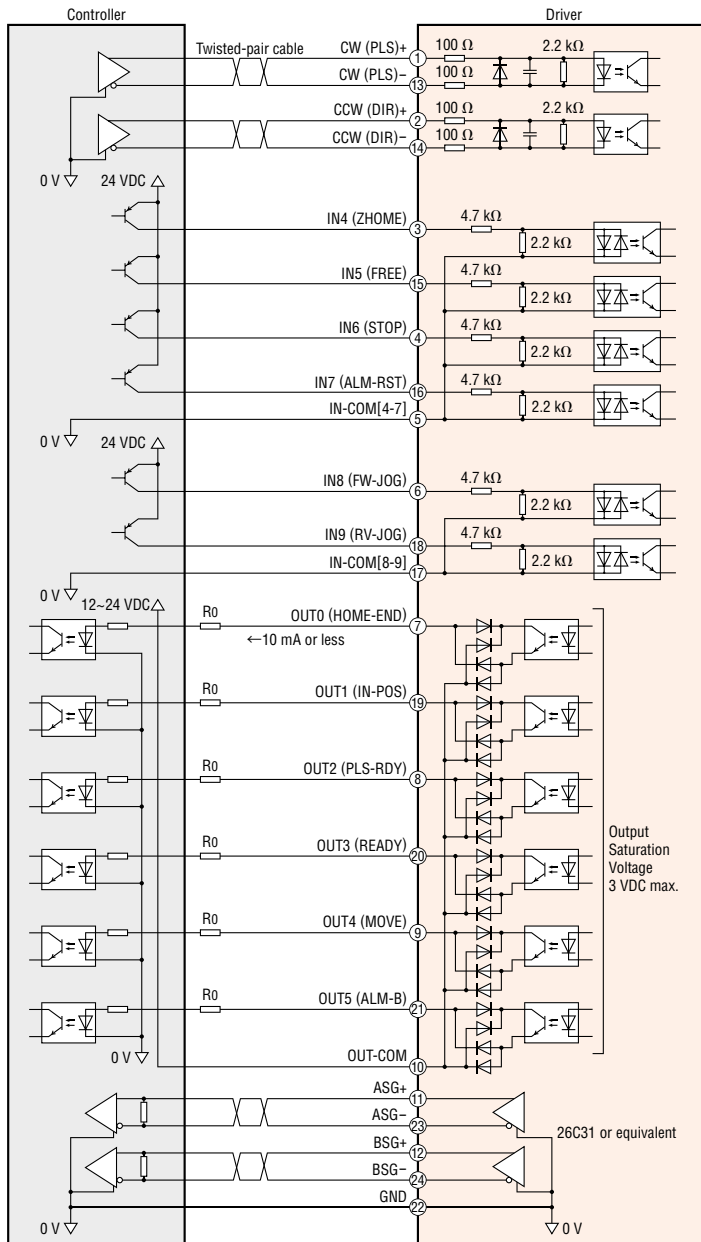

Notes

- Use 24 VDC for the input signals.
- Use output signal at 12~24 VDC 10 mA or less. When the current value exceeds 10 mA, connect to an external resistor R_0 to reduce the current to 10 mA or less.
- Make sure the signal line is wired at a distance of 200 mm or longer from the power line (power supply line and motor line). Furthermore, do not insert the signal line in the same pipe as the power lines or bundle them together.
- When noise is emitted from the motor cable or power cable due to wiring or allocation and it cause a problem, shield the cable or use ferrite cores.

When the pulse input is an open collector

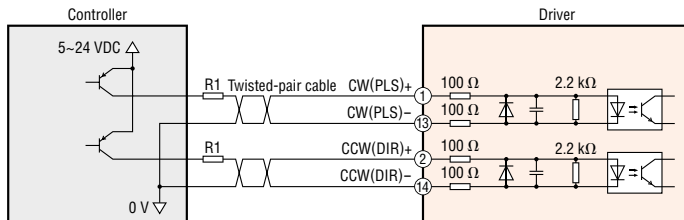

Notes

- For CW (PLS) input and CCW (DIR) input, use 5-24 VDC. Where the voltage exceeds 5 VDC, connect an external resistor R_1 to adjust the input current to be 7-20mA.

AZ Multi-Axis-Driver Series

DC Power supply

Supports EtherCAT Drive Profiles

The multi-axis driver corresponds to the EtherCAT communication drive profile CiA402. All of our **AZ** motors with DC power input and motorized actuators which are equipped with them can be connected. 2-axis, 3-axis, or 4-axis can be connected to the driver.



The Multi-axis driver achieves a space-saving and cost reduction (up to 4 axes)

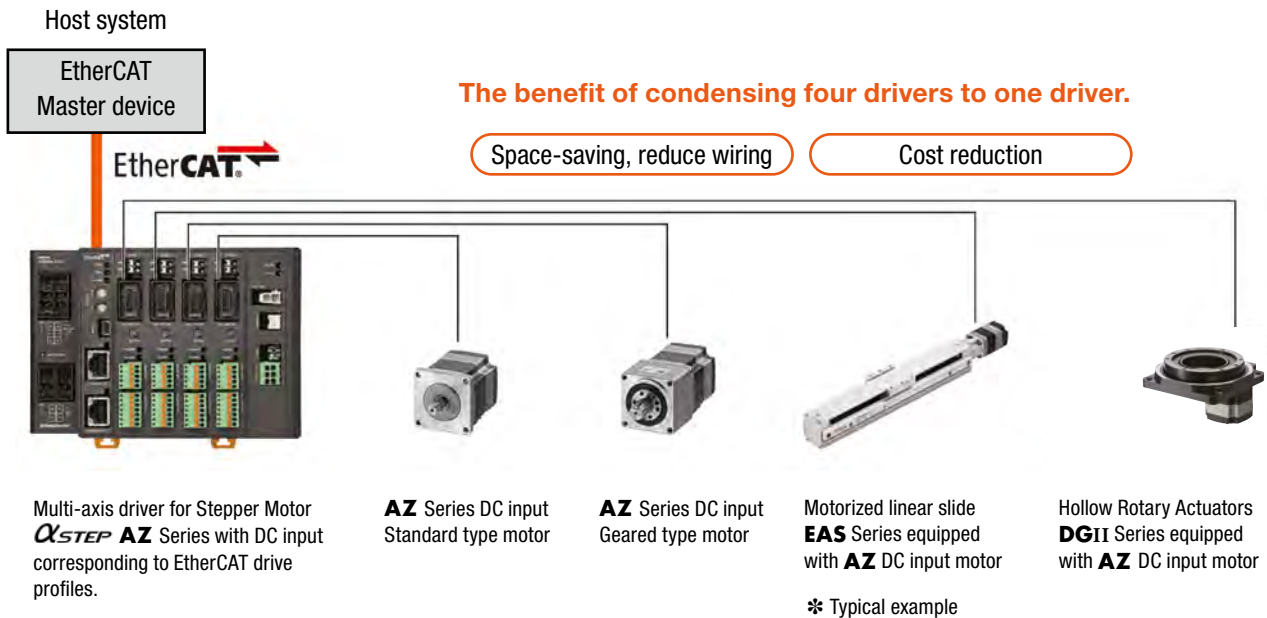

● The motors and actuators shown above are an example.

Types

Product Name	Number of axes
AZD2A-KED	2
AZD3A-KED	3
AZD4A-KED	4

Applicable Series

Motor	Actuator
Stepper motor αSTEP AZ Series DC power input	Electric slides EAS Series equipped with αSTEP AZ DC input motor Electric slides EZS Series equipped with αSTEP AZ DC input motor Electric cylinder EAC Series equipped with αSTEP AZ DC input motor Compact Linear actuator DRS2 Series equipped with αSTEP AZ DC input motor Hollow rotary actuator DGII Series equipped with αSTEP AZ DC input motor.

● Refer to each series' catalogue for applicable combinations with motors and actuators.

System configuration

Standard **AZ** DC Motor with electromagnetic brake

* Prepared by the customer

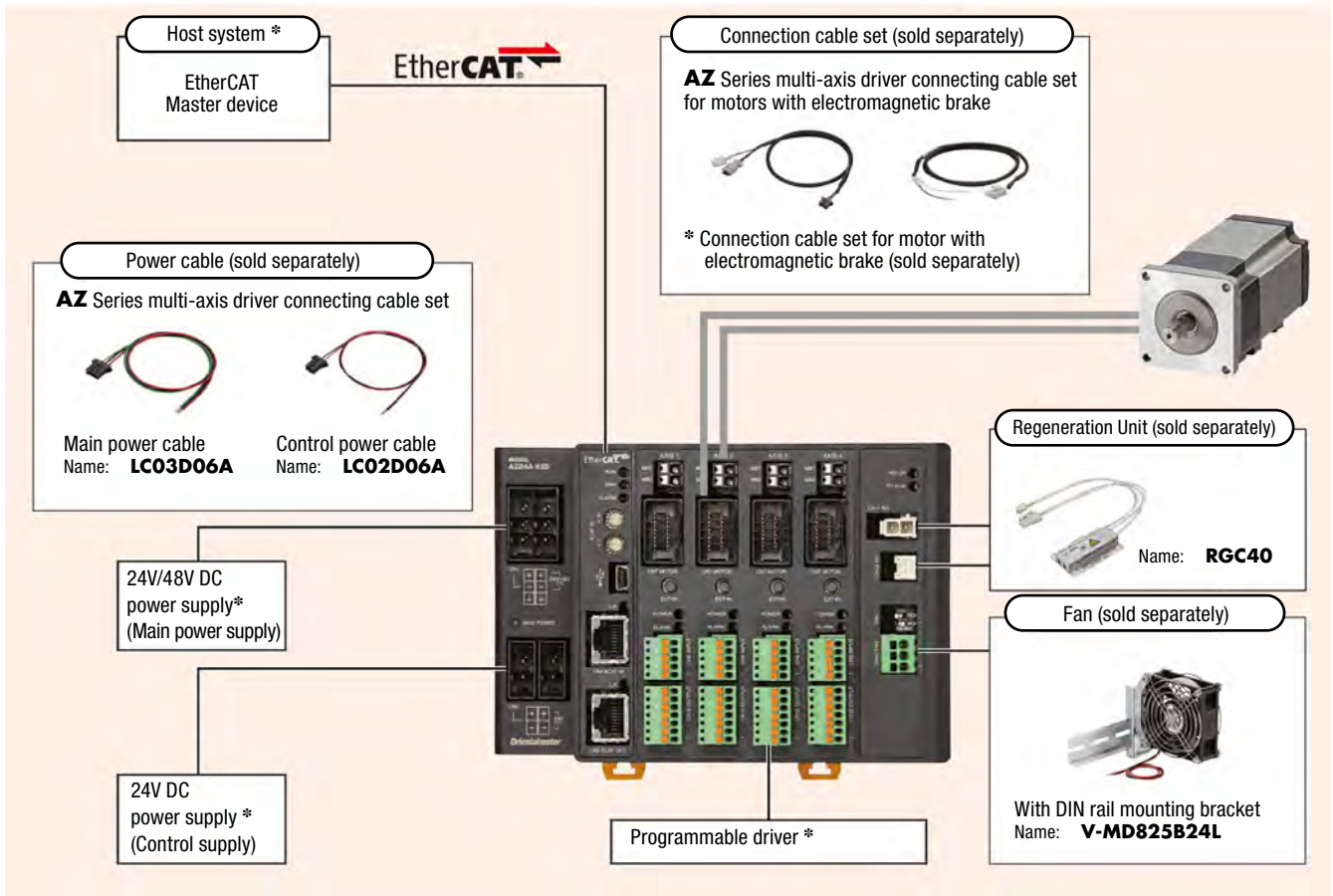

System Configuration Example

AZ Series			Accessory		
Motor	Driver	Connection Cable Sets	Sold Separately		
AZM66MK	AZD4A-KED	CC030VZFBA	Main Power Cable	Control Power Cable	Regeneration Unit
492.00 €	1,291.00 €	93.00 €	LC03D06A	LC02D06A	RGC40
			15.00 €	13.00 €	47.00 €

● The system configuration shown above is an example. Other combinations are also available.

Note

● The motor cable and electromagnetic brake cable from the motor cannot be connected directly to the driver. When connecting to a driver, use a connection cable.

Product Number

Motor

Standard Type

AZD 4A - K ED

① ② ③ ④

①	Driver Type	AZD: AZ Series Driver
②	Number of Axes	2A: 2 Axes 3A: 3 Axes 4A: 4 Axes
③	Power Supply Input	K: DC Power Supply Input
④	Type of communication	ED: EtherCAT Drive profile

Cables for multi-axis driver

Connection Cable Sets/Flexible Connection Cable Sets

For Standard Motor

CC 050 V Z F A

① ② ③ ④ ⑤ ⑥ ⑧

For Electro Magnetic type motor

CC 050 V Z F B A

① ② ③ ④ ⑥ ⑦ ⑧

①		CC: Cable
②	Length	005: 0.5 m 010: 1 m 015: 1.5 m 020: 2 m 025: 2.5 m 030: 3 m 040: 4 m 050: 5 m 070: 7 m 100: 10 m 150: 15 m 200: 20 m
③	Reference Number	
④	Applicable Models	Z: AZ Series
⑤	Reference Number	Blank: Frame Size 42 mm (HPG Geared Type is 40 mm), 60 mm 2: Frame Size 20 mm, 28 mm
⑥	Cable Type	F: Connection Cable Sets R: Flexible Connection Cable Sets
⑦	Electromagnetic Brake	B: With Electromagnetic Brake
⑧	Driver Type	A: For Multi-Axis Driver

Product Line

Multi-Axis Driver

EtherCAT Drive Profile Compliant



Product Name	Number of Axes	List Price
AZD2A-KED	2 Axes	807.00 €
AZD3A-KED	3 Axes	1,069.00 €
AZD4A-KED	4 Axes	1,291.00 €

AZ Series Multi-Axis Driver Connection Cable Sets/ Flexible Connection Cable Sets

Motor Connection Cables



Length L [m]	Frame Size 20 mm, 28 mm				Frame Size 42 mm, 60 mm			
	Connection Cable	List Price	Flexible Connection Cable	List Price	Connection Cable	List Price	Flexible Connection Cable	List Price
0.5	CC005VZ2FA	60.00 €	CC005VZ2RA	72.00 €	CC005VZFA	60.00 €	CC005VZRA	72.00 €
1	CC010VZ2FA	59.00 €	CC010VZ2RA	72.00 €	CC010VZFA	59.00 €	CC010VZRA	72.00 €
1.5	CC015VZ2FA	64.00 €	CC015VZ2RA	77.00 €	CC015VZFA	64.00 €	CC015VZRA	77.00 €
2	CC020VZ2FA	67.00 €	CC020VZ2RA	83.00 €	CC020VZFA	67.00 €	CC020VZRA	83.00 €
2.5	CC025VZ2FA	72.00 €	CC025VZ2RA	89.00 €	CC025VZFA	72.00 €	CC025VZRA	89.00 €
3	CC030VZ2FA	76.00 €	CC030VZ2RA	93.00 €	CC030VZFA	76.00 €	CC030VZRA	93.00 €
4	CC040VZ2FA	84.00 €	CC040VZ2RA	107.00 €	CC040VZFA	84.00 €	CC040VZRA	107.00 €
5	CC050VZ2FA	92.00 €	CC050VZ2RA	119.00 €	CC050VZFA	92.00 €	CC050VZRA	119.00 €
7	CC070VZ2FA	114.00 €	CC070VZ2RA	152.00 €	CC070VZFA	114.00 €	CC070VZRA	152.00 €
10	CC100VZ2FA	149.00 €	CC100VZ2RA	200.00 €	CC100VZFA	149.00 €	CC100VZRA	200.00 €
15	CC150VZ2FA	206.00 €	CC150VZ2RA	280.00 €	CC150VZFA	206.00 €	CC150VZRA	280.00 €
20	CC200VZ2FA	261.00 €	CC200VZ2RA	359.00 €	CC200VZFA	261.00 €	CC200VZRA	359.00 €

Features

System
Configuration

Product Line

Specifications
and Features

Dimensions

Connection
and Operation

System
Configuration

Product Line

Specifications
and Features

Dimensions

Connection
and Operation

MultiAxis
Driver

Accessories

DC Input

AC Input

◇ Connection Cables for Motors with Electromagnetic Brake

Length L [m]	Frame Size 42 mm, 60 mm			
	Connection Cable	List Price	Flexible Connection Cable	List Price
0.5	CC005VZFBA	72.00 €	CC005VZRBA	95.00 €
1	CC010VZFBA	72.00 €	CC010VZRBA	95.00 €
1.5	CC015VZFBA	78.00 €	CC015VZRBA	105.00 €
2	CC020VZFBA	83.00 €	CC020VZRBA	114.00 €
2.5	CC025VZFBA	90.00 €	CC025VZRBA	119.00 €
3	CC030VZFBA	93.00 €	CC030VZRBA	127.00 €
4	CC040VZFBA	104.00 €	CC040VZRBA	143.00 €
5	CC050VZFBA	113.00 €	CC050VZRBA	161.00 €
7	CC070VZFBA	140.00 €	CC070VZRBA	203.00 €
10	CC100VZFBA	180.00 €	CC100VZRBA	261.00 €
15	CC150VZFBA	248.00 €	CC150VZRBA	365.00 €
20	CC200VZFBA	314.00 €	CC200VZRBA	465.00 €



Note

● For the Multi-Axis Driver only connection cables are provided. AZ Series extension cables cannot be used.

Included

● Multi-Axis Driver

Type, Number of Axes	Included	Connector for CN1	Connector for CN2	Contact for CN1, CN2	Connector Cap for CN4, CN5	Connector for CN9	Connector for CN10	Operating Manual
EtherCAT Compliant	2 Axes	2 Pieces	2 Pieces	10 Pieces	2 Pieces	2 Pieces	2 Pieces	1 Copy
	3 Axes	2 Pieces	2 Pieces	10 Pieces	2 Pieces	3 Pieces	3 Pieces	1 Copy
	4 Axes	2 Pieces	2 Pieces	10 Pieces	2 Pieces	4 Pieces	4 Pieces	1 Copy

Specifications

● Power Supply Input

Main Power Supply: 24/48 VDC ±10% 7.0A (Max. 7.0 A, please use average 4.0 A or less)

Control Power Supply: 24 VDC ±10% 1.5A (For the type with an electromagnetic brake a 24 VDC±5% specification applies)

(For the type with an electromagnetic brake with 20 m connection cable a 24 VDC ±4% specification applies)

◇ EtherCAT Specifications

Item	Content
Baud Rate	100 Mbps
Communication Period	0.5ms/1ms/2ms/3ms/4ms/5ms/6ms/7ms/8ms
Node Address	0~255(00h~FFh, initial value:00h)
Communication Protocol	EtherCAT dedicated protocol (CoE) CiA402 drive profile

● General Specification

Item	Content
Degree of Protection	IP10
Operating Environment	Ambient temperature: 0~+50°C (Non-freezing) Ambient Humidity: 85 % or less (Non-condensing) Altitude: Max. 1000 m above sea level Atmosphere: No corrosive gases or dust. The product should not be exposed to water, oil or other liquids.
Storage, Transportation Environment	Ambient temperature: -25~+70°C (Non-freezing) Ambient Humidity: 85 % or less (Non-condensing) Altitude: Max. 3000 m above sea level Atmosphere: No corrosive gases or dust. The product should not be exposed to water, oil or other liquids.
Insulation Resistance	100MΩ or more when a 500 VDC megger is applied between the following parts: - FG Terminal - Power Supply Terminal
Dielectric Voltage	Sufficient to withstand for 1 minute: - EtherCAT Compliant: FG Terminal - Power Supply Terminal 1 kVAC, 50 Hz or 60 Hz, leakage current 10 mA or less

Note

● Do not measure insulation resistance or perform a dielectric strength test while the motor and driver are connected. Also, do not perform these tests on the motor absolute sensor part.

■ Dimensions (Unit = mm)

● Multi-Axis Driver (EtherCAT Compliant)

Number of Axes	Type	Product Name	Mass [kg]
2 Axes		AZD2A-KED	0.39
3 Axes		AZD3A-KED	0.42
4 Axes		AZD4A-KED	0.45

- The dimensions for 2 axes, 3 axes and 4 axes are the same.
- Included
 - Connector for Main Power: F32FSS-03V-KX (JST)
 - Connector for Control Power: F32FSS-02V-KX (JST)
 - Connector for Main Power/Control Power: LF3F-41GF-P2.0 (JST)
 - Connector for Input Signals: FK-MC 0,5/ 5-ST-2,5 (PHOENIX CONTACT)
 - Connector for Output Signals: FK-MC 0,5/ 7-ST-2,5 (PHOENIX CONTACT)

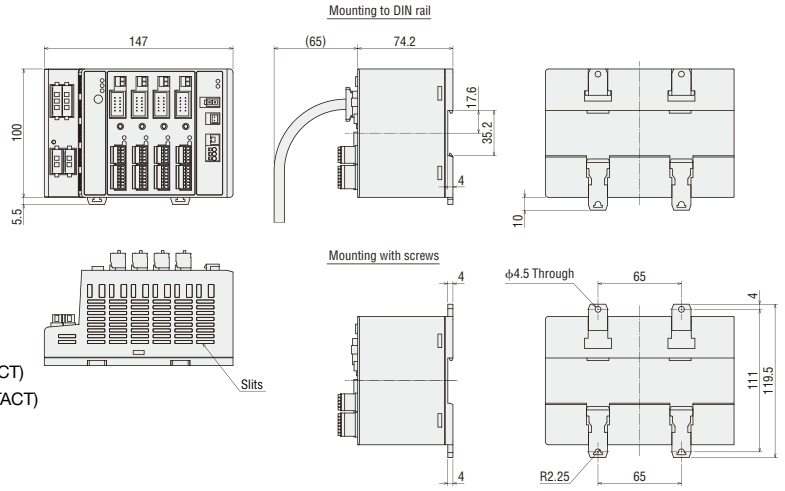

● Connection Cable Sets/Flexible Connection Cable Sets

◇ Cable for Motor

● Frame Size 20 mm, 28 mm

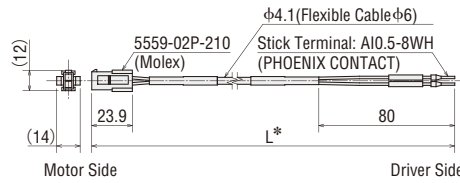
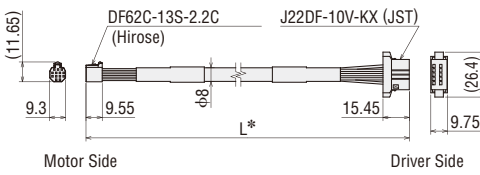

*The length L [m] is specified where L is located in the dimensions in "Product Line" on page 112-113

● Frame Size 42 mm, 60 mm

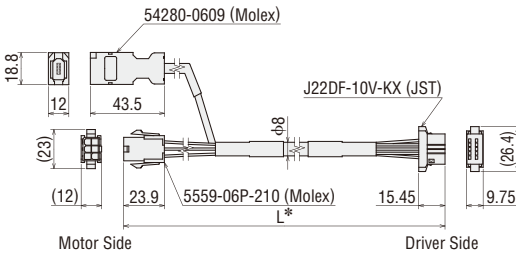

◇ Cable for Electromagnetic Brake

● Frame Size 42 mm, 60 mm

Features

System Configuration

Product Line

Specifications and Features

Dimensions

Connection and Operation

System Configuration

Product Line

Specifications and Features

Dimensions

Connection and Operation

Multiaxis Driver

Accessories

AC Input

DC Input

Multi-Axis Driver Accessories

Power Supply Cables (Sold Separately)

Lead wire cables with connectors for **AZ** Series Multi-Axis Drivers. Main power supply and control power supply can be connected easily.

Product Line

Product Name	Type	List Price
LC03D06A	Main Power Supply	15.00 €
LC02D06A	Control Power Supply	13.00 €



Dimensions (Unit = mm)

Cable for Main Power Supply

LC03D06A

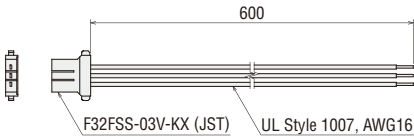

Cable for Control Power Supply

LC02D06A

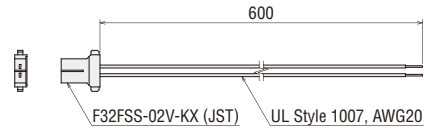

Regeneration Unit

During vertical drive (gravitational operation) or sudden start/stop with high inertia, an external force causes the motor to rotate and work as a power generator. When the regenerative power exceeds the driver's regenerative power absorption capacity, it may cause damage to the motor. In such a case, the regeneration unit need to be connected to the driver to convert regenerative energy into thermal energy for dissipation.

As the Multi-Axis Driver uses 24/48 VDC, an alarm output can happen easily, therefore the use of a regeneration unit is recommended.



Product Line

Product Name	List Price
RGC40	47.00 €

Specification

Item	Content
Permissible Power Consumption	*Continuous regenerative power: 40 W Instantaneous regenerative power: 400 W
Resistance Value	15Ω
Thermostat Operating Temperature	Operation: 95±5°C Reset: 65±15°C (Normally closed)
Thermostat Electrical Rating	250 VAC 0.5 A (Min. current 1.5 VDC 1 mA)

*Install the regeneration unit in a place that has the same heat radiation capability as the heat sink (material: aluminum 180x150 mm, 2 mm thick).

Dimensions (Unit = mm)

Mass: 0.03 kg

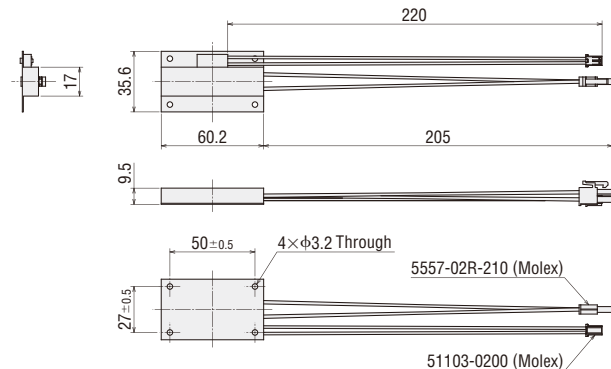

Accessories (Sold separately)

Connection Cable Sets, Flexible Connection Cable Sets Extension Cable Sets, Flexible Extension Cable Sets

The extension cable maximum extension length is 20 m (including attached cable).

For the standard motor, the cable for motor cable and the cable for encoder make up the set. Whereas for the magnetic brake-attached motor, the cable for motor, the cable for encoder and the cable for magnetic brake make up the set.

If the cable becomes bent, use the flexible connection cable set or flexible extension cable set.

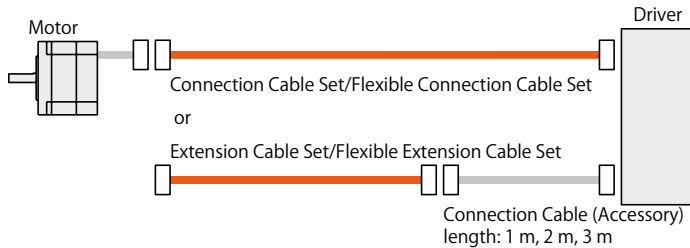

Notes

● Cables for motor and magnetic brake from the motor cannot be connected directly to the driver. When connecting to the driver, use the optional (sold separately) connection cable or the connection cable attached to the product (only for types with a connection cable attached).

AC Input

Extension Cable Sets, Flexible Extension Cable Set

Product Line

Extension Cable Sets

◇ For Standard Motor



Cable for Motor

Cable for Encoder

Product Name	Length L [m]	List Price
CC010VZFT	1	60.00 €
CC020VZFT	2	68.00 €
CC030VZFT	3	77.00 €
CC050VZFT	5	92.00 €
CC070VZFT	7	114.00 €
CC100VZFT	10	149.00 €
CC150VZFT	15	206.00 €

◇ For Electromagnetic Brake Motor



Cable for Motor

Cable for Encoder

Cable for Electromagnetic Brake

Product Name	Length L [m]	List Price
CC010VZFBT	1	72.00 €
CC020VZFBT	2	83.00 €
CC030VZFBT	3	93.00 €
CC050VZFBT	5	113.00 €
CC070VZFBT	7	140.00 €
CC100VZFBT	10	180.00 €
CC150VZFBT	15	248.00 €

Flexible Extension Cable Sets

◇ For Standard Motor



Cable for Motor

Cable for Encoder

Product Name	Length L [m]	List Price
CC010VZRT	1	72.00 €
CC020VZRT	2	83.00 €
CC030VZRT	3	93.00 €
CC050VZRT	5	119.00 €
CC070VZRT	7	151.00 €
CC100VZRT	10	200.00 €
CC150VZRT	15	289.00 €

◇ For Electromagnetic Brake Motor



Cable for Motor

Cable for Encoder

Cable for Electromagnetic Brake

Product Name	Length L [m]	List Price
CC010VZRBt	1	95.00 €
CC020VZRBt	2	114.00 €
CC030VZRBt	3	127.00 €
CC050VZRBt	5	161.00 €
CC070VZRBt	7	203.00 €
CC100VZRBt	10	261.00 €
CC150VZRBt	15	365.00 €

Dimensions (Unit = mm)

● Connection Cable

◇ Motor Cable

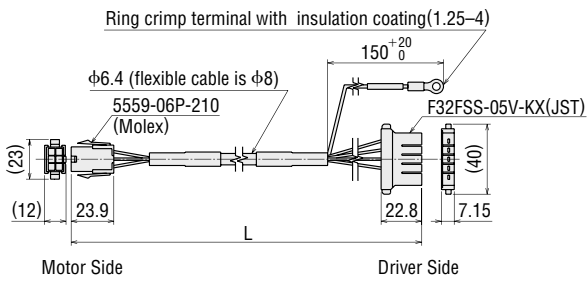

◇ Encoder Cable

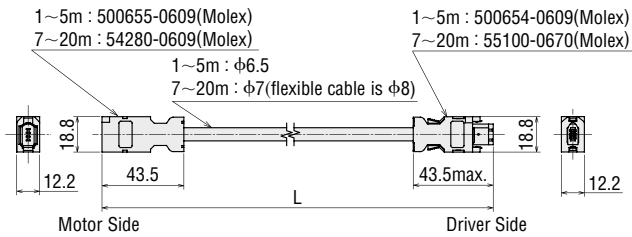

◇ Electromagnetic Brake Cable

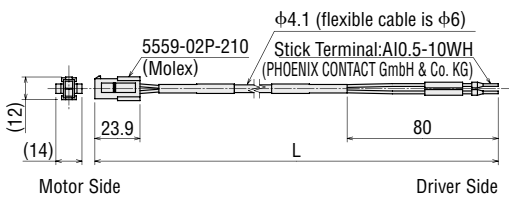

● Extension Cable

◇ Motor Cable

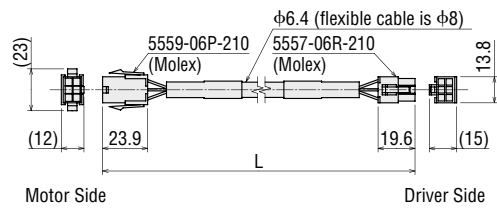

◇ Encoder Cable

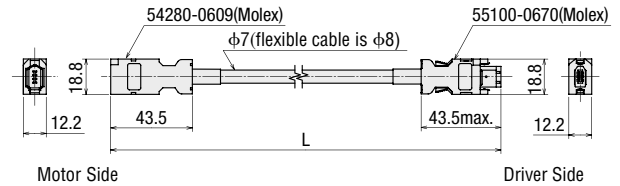

◇ Electromagnetic Brake Cable

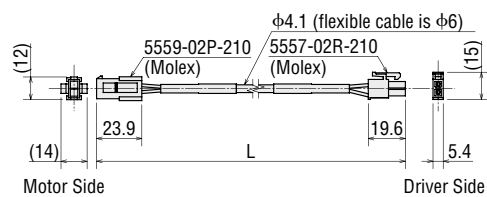

DC Input

Extension Cable Sets, Flexible Extension Cable Sets

● Product Line

[For **AZ14, AZ15, AZ24, AZ26**]

● Extension Cable

◇ For Standard Motor



● Flexible Extension Cable

◇ For Standard Motor



Product Name	Length L [m]	List Price
CC010VZ2RT	1	72.00 €
CC020VZ2RT	2	83.00 €
CC030VZ2RT	3	93.00 €
CC050VZ2RT	5	119.00 €
CC070VZ2RT	7	152.00 €
CC100VZ2RT	10	200.00 €
CC150VZ2RT	15	280.00 €

[For **AZ46, AZ48, AZ66, AZ69**]

● Extension Cable Sets

◇ For Standard Motor



Cable for Motor

Cable for Encoder

Product Name	Length L [m]	List Price
CC010VZFT	1	60.00 €
CC020VZFT	2	68.00 €
CC030VZFT	3	77.00 €
CC050VZFT	5	92.00 €
CC070VZFT	7	114.00 €
CC100VZFT	10	149.00 €
CC150VZFT	15	206.00 €

◇ For Electromagnetic Brake Motor



Cable for Motor

Cable for Encoder

Cable for Electromagnetic Brake

Product Name	Length L [m]	List Price
CC010VZFBT	1	72.00 €
CC020VZFBT	2	83.00 €
CC030VZFBT	3	93.00 €
CC050VZFBT	5	113.00 €
CC070VZFBT	7	140.00 €
CC100VZFBT	10	180.00 €
CC150VZFBT	15	248.00 €

● Flexible Extension Cable Sets

◇ For Standard Motor



Cable for Motor

Cable for Encoder

Product Name	Length L [m]	List Price
CC010VZRT	1	72.00 €
CC020VZRT	2	83.00 €
CC030VZRT	3	93.00 €
CC050VZRT	5	119.00 €
CC070VZRT	7	151.00 €
CC100VZRT	10	200.00 €
CC150VZRT	15	289.00 €

◇ For Electromagnetic Brake Motor



Cable for Motor

Cable for Encoder

Cable for Electromagnetic Brake

Product Name	Length L [m]	List Price
CC010VZRB	1	95.00 €
CC020VZRB	2	114.00 €
CC030VZRB	3	127.00 €
CC050VZRB	5	161.00 €
CC070VZRB	7	203.00 €
CC100VZRB	10	261.00 €
CC150VZRB	15	365.00 €

■ Dimensions (Unit = mm)

[For AZ14, AZ15, AZ24, AZ26]

● Connection Cable

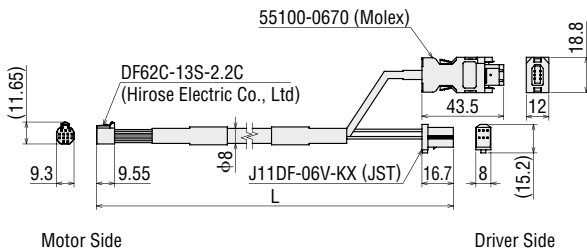

Motor Side

Driver Side

● Extension Cable

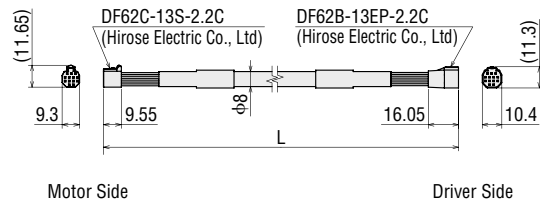

Motor Side

Driver Side

[For AZ46, AZ66, AZ69]

● Connection Cable

◇ Cable for Motor

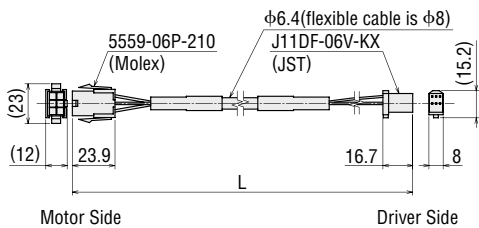

Motor Side

Driver Side

◇ Cable for Electromagnetic Brake

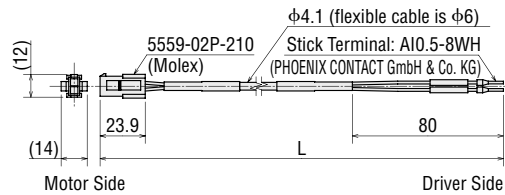

Motor Side

Driver Side

◇ Cable for Encoder

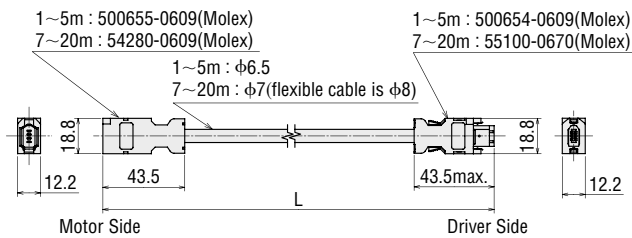

Motor Side

Driver Side

● Extension Cable

◇ Cable for Motor

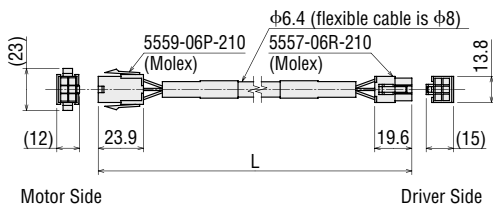

Motor Side

Driver Side

◇ Cable for Electromagnetic Brake

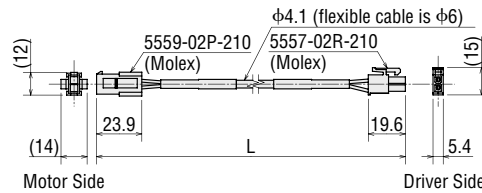

Motor Side

Driver Side

◇ Cable for Encoder

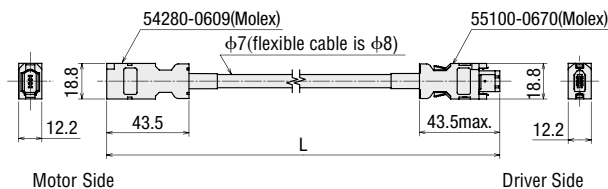

Motor Side

Driver Side

Notes on Use of a Flexible Cable

① Do not allow the cable to bend at the cable connector.

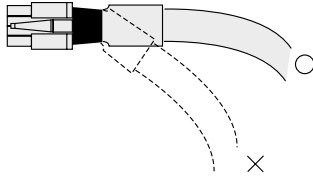

② For the bending radius, use at six times or more of the cable diameter.

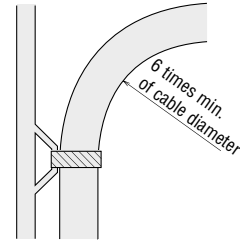

③ The cable wired from the motor or the cable comes as a set of the motor should not be bended. Use a flexible motor cable, if the cable will be bend.

• Flexible Connection Cable

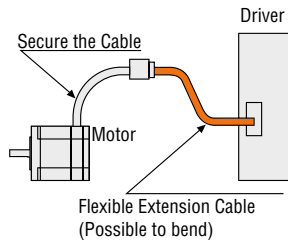

• Flexible Extension Cable

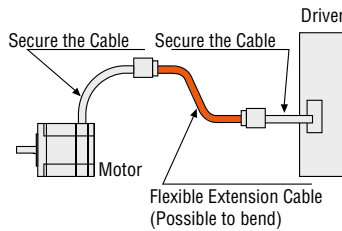

Generic Cable for Input/Output Signals

This is a convenient multi-core cable for connecting the driver and upper level controller. Choose the necessary cable in accordance with the number of connecting I/O signals.



Product Line

Lead wire No. of cores	Cable Length [m]			
	0.5	1	1.5	2
6	CC06D005B-1	CC06D010B-1	CC06D015B-1	CC06D020B-1
10	CC10D005B-1	CC10D010B-1	CC10D015B-1	CC10D020B-1
12	CC12D005B-1	CC12D010B-1	CC12D015B-1	CC12D020B-1
16	CC16D005B-1	CC16D010B-1	CC16D015B-1	CC16D020B-1

Dimensions (Unit = mm)

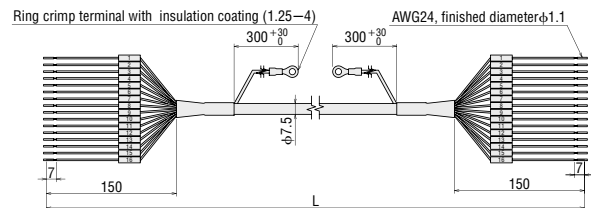

● The outline drawing is of 16 cores.

RS-485 Communication Cable

The cable is to link drivers when the driver is being operated under multi-axis mode, it also connects the network converter and driver.



Product Line

Product Name	Applicable Product	Length L [m]
CC001-RS4	DC Power Supply Input Driver	0.1
CC002-RS4	AC Power Supply Input Driver DC Power Supply Input Driver	0.25

Dimensions (Unit = mm)

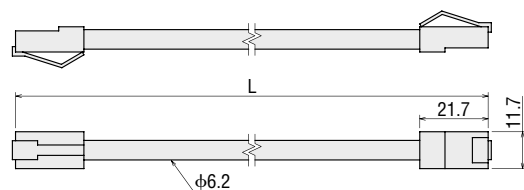

Communication Cable for FLEX

Product Line

Product Line	Product Name	Length L [m]	List Price
General-Purpose Type*1	CC02FLT	2	52.00 €
	CC05FLT	5	75.00 €
Special-Purpose Type*2 Digital Electronics Corporation GP3000 Series for COM1 LT3300 Series GP4000 Series COM1, COM2, for RS-485	CC02FLT2	2	112.00 €
	CC05FLT2	5	135.00 €
Special-Purpose Type*2 Digital Electronics Corporation GP3000 Series for COM2*3	CC02FLT3	2	102.00 €
	CC05FLT3	5	123.00 €

*1 A terminating resistor is included.

*2 A terminating resistor is built-in.

*3 When the product for COM2 is used, the online adapter CA4-ADP0NL-01, an accessory from Digital Electronics Corporation, is required.



General-Purpose



Special-Purpose

Dimensions Unit = mm

◇ General-Purpose

CC02FLT, CC05FLT

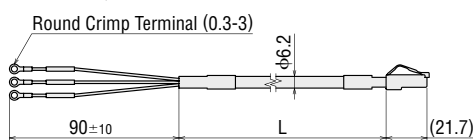

◇ Special-Purpose

CC02FLT2, CC05FLT2

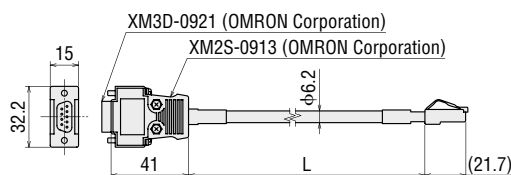

CC02FLT3, CC05FLT3

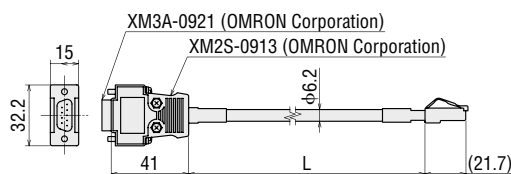

Data Setting Software MEXE02

From the computer, it is not only possible to set and edit driving data and the various parameters, but also to monitor the waveforms of teaching, I/O and driving speed.

The data setting software is available for download from our website.

Furthermore, the data setting software is distributed on a CD-ROM.

For details, ask from our website or inquire at your nearest branch or sales office.

Operating Environment

Computer

Recommended CPU*1	Intel Core Processor 2 GHz or more (The OS must be supported.)
Display	high resolution video adapter and monitor, XGA (1024x768) or more.
Recommended Memory*1	32 bit (x86) version: 1 GB or more 64 bit (x64) version: 2 GB or more
Hard Disk*2	Available disk space of 60 MB or more
USB Port	USB 2.0 1 port
Disk Device	CD-ROM drive (use for installation of software)

*1 The OS operating conditions need to be satisfied.

*2 Microsoft .NET Framework 4 Client Profile is required to use **MEXE02**. If it is not already installed, it will be installed automatically, in which case up to 1.5 GB of additional space is required.

● Windows and Windows Vista are registered trademarks of Microsoft Corporation in the United States and other countries. Pentium is a trademark of Intel Corporation.

● Please refer to our website for the latest update of operating environment.

Notes

● The required volume of memory or hard disk may vary depending on the system environment.

Operating Systems (OS)

Both the 32-bit (x86) and 64 bit (x64) editions are supported.

- Microsoft Windows Vista Service Pack 2
- Microsoft Windows 7 Service Pack 1
- Microsoft Windows 8
- Microsoft Windows 8.1
- Microsoft Windows 10

*This works with Service Pack 2 when using 64 bit (x64) edition.

Connection between Computer and Driver

Use the following specifications for the USB cable.

Specification	USB 2.0 (full speed)
Cable	Length: 3 m (or less) Format: A-mini-B

Features

System Configuration

Product Line

Specifications and Features

Dimensions

Connection and Operation

System Configuration

Product Line

Specifications and Features

DC Input

Dimensions

Connection and Operation

MultiAxis Driver

Accessories

MCV Couplings

This is a one piece structure coupling with the vibration-proof rubber formed between the aluminium alloy hubs.



Product Line

Product Name

MCV15□

MCV19□

MCV25□

MCV30□

● A number indicating the coupling inner diameter is entered where the box is located within the product name.

Product Number Code

MCV 25 10 12

① ② ③ ④

①	MCV Couplings
②	Outer Diameter of Coupling
③	Inner Diameter d1 (smaller inner diameter) (06A represents $\phi 6.35$ mm)
④	Inner Diameter d2 (larger inner diameter) (06A represents $\phi 6.35$ mm)

● For inner diameter d1, the smaller of the motor shaft diameter or the driven shaft diameter is entered.
For inner diameter d2, the larger of the motor shaft diameter or the driven shaft diameter is entered.

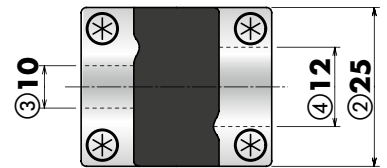

Coupling Selection Table

- Coupling is selected based on the following content.
 - The motor output torque is within the generic torque for coupling.
 - Motor shaft diameter

Applicable Product			Coupling	Motor Shaft Diameter [mm]		Driven Shaft Diameter [mm]										
Frame Size [mm]	Product Name	Coupling				Motor Shaft Diameter [mm]	03	04	05	06	06A	08	10	12	14	15
							$\phi 3$	$\phi 4$	$\phi 5$	$\phi 6$	$\phi 6.35$	$\phi 8$	$\phi 10$	$\phi 12$	$\phi 14$	$\phi 15$
Standard	20	AZ14, AZ15	MCV15	04	$\phi 4$		●	●	●							
	28	AZ24, AZ26		05	$\phi 5$	●	●	●	●							
	40	AZ46		06	$\phi 6$		●	●	●							
		AZ48	MCV19	08	$\phi 8$			●	●		●					
	60	AZ66, AZ69	MCV25	10	$\phi 10$				●	●	●	●				
	85	AZ98, AZ911	MCV30	14	$\phi 14$						●	●	●	●		

● The applicable product name includes the characters that can distinguish the product name.

MCS Couplings

This is a three piece structure coupling comprised of aluminium alloy hubs and resin spiders.



Product Line

Product Name

MCS20

MCS30

MCS40

MCS55

MCS65

● A number indicating the coupling inner diameter is entered where the box is located within the product name.

Product Number Code

MCS 30 10 12

① ② ③ ④

①	MCS Couplings
②	Outer Diameter of Coupling
③	Inner Diameter d1 (smaller inner diameter) (FO4 represents φ6.35 mm)
④	Inner Diameter d2 (larger inner diameter) (FO4 represents φ6.35 mm)

● For inner diameter d1, the smaller of the motor shaft diameter or the driven shaft diameter is entered.
For inner diameter d2, the larger of the motor shaft diameter or the driven shaft diameter is entered.

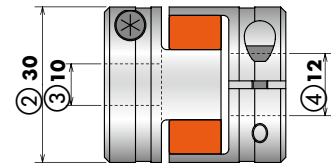

Coupling Selection Table

- Coupling is selected based on the following content.
 - The motor output torque is within the generic torque for coupling.
 - Motor shaft diameter
- When using the parallel key, choose an appropriate coupling for the parallel key.

	Applicable Product		Gear Ratio	Coupling	Motor Shaft Diameter [mm]	Driven Shaft Diameter [mm]																		
	Frame Size [mm]	Product Name				05	06	FO4	08	10	12	14	15	16	18	20	22	24	25					
						φ5	φ6	φ6.35	φ8	φ10	φ12	φ14	φ15	φ16	φ18	φ20	φ22	φ24	φ25					
TS Gear	42	AZ46-TS <input type="checkbox"/>	3.6, 7.2	MCS20	06	φ6	●	●	●	●	●													
			10, 20, 30	MCS30				●	●	●	●	●	●	●										
	60	AZ66-TS <input type="checkbox"/>	3.6, 7.2	MCS30	10	φ10		●	●	●	●	●	●	●										
			10, 20, 30	MCS40					●	●	●	●	●	●	●									
	90	AZ98-TS <input type="checkbox"/>	3.6, 7.2, 10	MCS55	18	φ18					●	●	●	●	●	●	●	●	●	●	●	●	●	●
			20, 30	MCS65									●	●	●	●	●	●	●	●	●	●	●	●
FC Gear	42	AZ46-FC <input type="checkbox"/>	7.2, 10, 20, 30	MCS20	10	φ10	●	●	●	●	●													
				MCS30						●	●	●	●											
	60	AZ66-FC <input type="checkbox"/>		MCS40	15	φ15				●	●													
				MCS55						●	●				●									
PS Gear	42	AZ46-PS <input type="checkbox"/>	5	MCS20	10	φ10	●	●	●	●	●													
			7.2, 10, 25, 36, 50	MCS30				●	●	●	●	●	●											
	60	AZ66-PS <input type="checkbox"/>	5, 7.2	MCS40	12	φ12				●	●	●	●	●	●	●	●	●	●	●	●	●	●	
			10, 25, 36, 50	MCS55							●	●	●	●	●	●	●	●	●	●	●	●	●	●
	90	AZ98-PS <input type="checkbox"/>	5, 7.2	MCS55	18	φ18					●	●	●	●	●	●	●	●	●	●	●	●	●	
			10, 25, 36, 50	MCS65									●	●	●	●	●	●	●	●	●	●	●	●
HPG Gear	40	AZ46-HP <input type="checkbox"/>	5, 9	MCS30	10	φ10		●	●	●	●	●	●	●										
	60	AZ66-HP <input type="checkbox"/>	5, 15	MCS55	16	φ16					●	●					●							
	90	AZ98-HP <input type="checkbox"/>	5, 15	MCS65	25	φ25											●	●						
Harmonic Gear	42	AZ46-HS <input type="checkbox"/>	50, 100	MCS40	10	φ10				●	●	●	●	●	●	●	●	●	●	●	●	●		
	60	AZ66-HS <input type="checkbox"/>	50, 100	MCS55	15	φ15					●	●					●							

- The applicable product name includes the characters that can distinguish the product name.
- The within the product name includes a number expressing the reduction ratio.

Motor Mounting Brackets

Mounting brackets are convenient for installation and securing a stepping motor and geared stepping motor.
The attachment fitting fixing section is a convenient long hole specification for adjusting belt tension after assembling the motor.



Product Line

Standard

Material: Aluminum Alloy (SPCC)*

Surface processing: paint (electroless nickel plating)*

Product Name	Motor Frame Size [mm]	Applicable Product
PFB28A	28	AZ24, AZ26
PAFOP	42	AZ46, AZ48
PALOP		
PAL2P-5	60	AZ66, AZ69
PAL4P-5	85	AZ98, AZ911

*The **PFB28A** specification is indicated within ().

- These mounting brackets can be perfectly fitted to the pilot of the stepping motors. (Except for **PALOP**)
- There is a motor attachment screw attached.

TS Gear

Material: Aluminum Alloy

Surface processing: painting

Product Name	Motor Frame Size [mm]	Applicable Product
SOLOB	42	AZ46
SOL2M4	60	AZ66
SOL5M8	90	AZ98

PS Gear

Material: SS400

Surface processing: electroless nickel plating

Product Name	Motor Frame Size [mm]	Applicable Product
PLA60G	60	AZ66
PLA90G	90	AZ98

- There is a motor attachment screw attached.

Harmonic Gear

Material: SS400

Surface processing: electroless nickel plating

Product Name	Motor Frame Size [mm]	Applicable Product
PLA60H	60	AZ66
PLA90H	90	AZ98

- There is a motor attachment screw attached.

Motor Mounting Direction

The motor cable comes out at right angles to the motor. Orient the motor so that the cable faces either upward or sideways.

- For **PLA60G, PLA90G, PLA60H, PLA90H**: The cable can face downward.

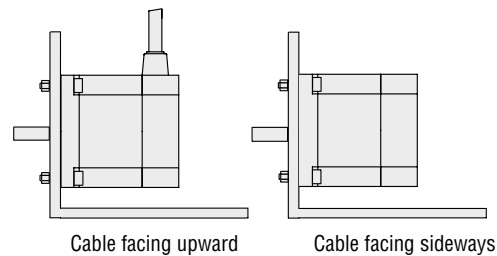

How to mount the motor

1 PAL2P-5, SOL2M4 PAL4P-5, SOL5M8

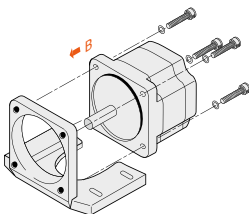

- ① Use the screws provided to secure the motor to the mounting bracket.
- ② Attach the motor from the direction shown by the arrow (B).

2 PALOP, SOLOB

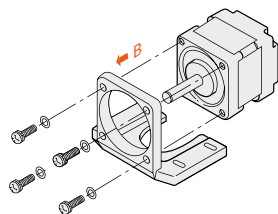

- ① Use the screws provided to secure the motor to the mounting bracket.
- ② Attach the motor from the direction shown by the arrow (B).

3 PAFOP, PFB28A

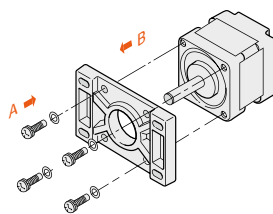

- ① Use the screws provided to secure the motor to the mounting bracket.
- ② Attach motor from the direction shown by either arrow (A) or arrow (B).

4 PLA60G, PLA60H PLA90G, PLA90H

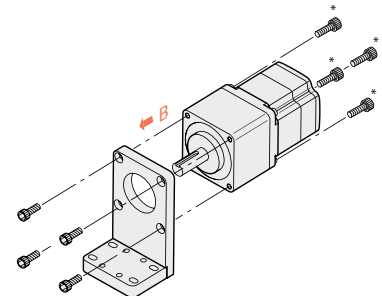

- ① Use the screw to attach the motor to the attachment fitting.
- ② Attach the motor from the direction shown by the arrow (B).
Motor mounting hole on **PLA90H** is processed with tapping. Insert the screw from direction B.

Dimensions (Unit = mm)

PFB28A

Mass: 25 g

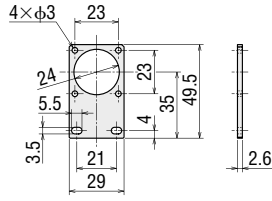

- Mounting Screws: M2.5 Length 5 mm
Included 4 pieces

PALOP

Mass: 35 g

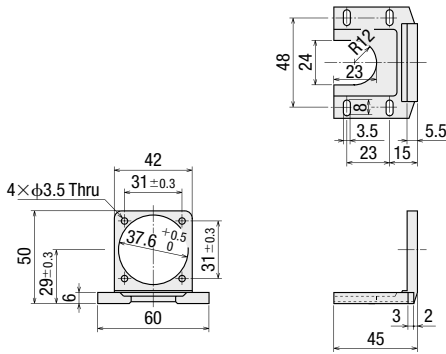

- Mounting Screws: M3 Length 10 mm
Included 4 pieces

PAL4P-5

Mass: 250 g

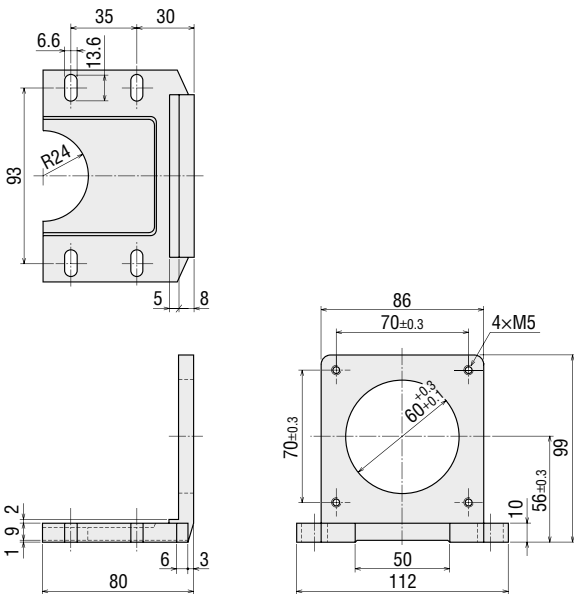

- Mounting Screws: M5 Length 16 mm
Included 4 pieces

PAFOP

Mass: 30 g

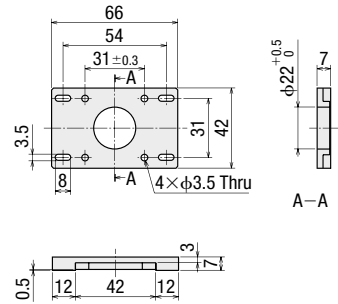

- Mounting Screws: M3 Length 7 mm
Included 4 pieces

PAL2P-5

Mass: 110 g

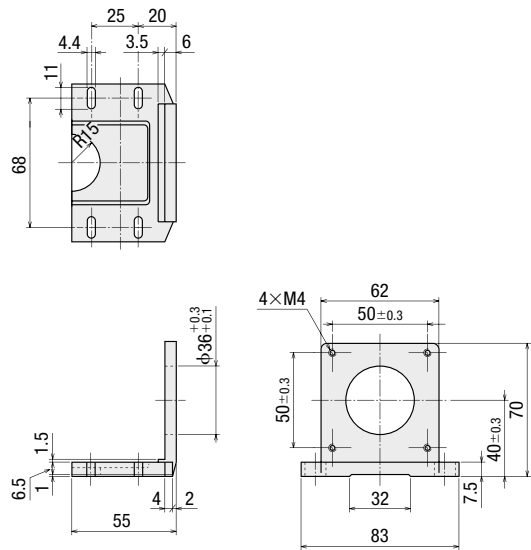

- Mounting Screws: M4 Length 12 mm
Included 4 pieces

SOLOB

Mass: 85 g

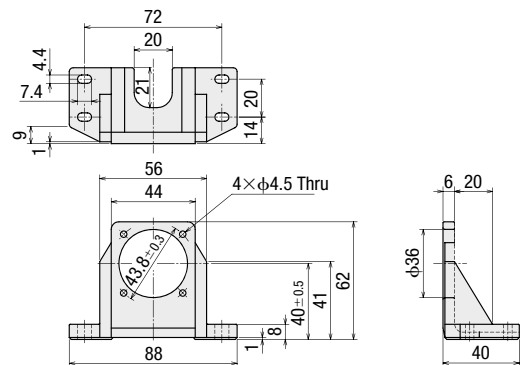

Features
System Configuration
Product Line
Specifications and Features
Dimensions
Connection and Operation
System Configuration
Product Line
Specifications and Features
Dimensions
Connection and Operation
Multiaxis Driver

Accessories

SOL2M4

Mass: 135 g

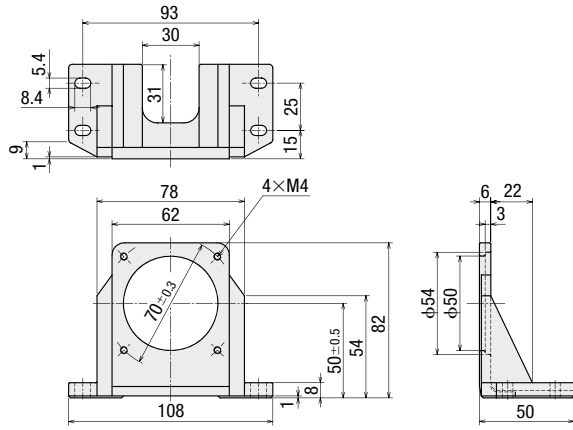

SOL5M8

Mass: 270 g

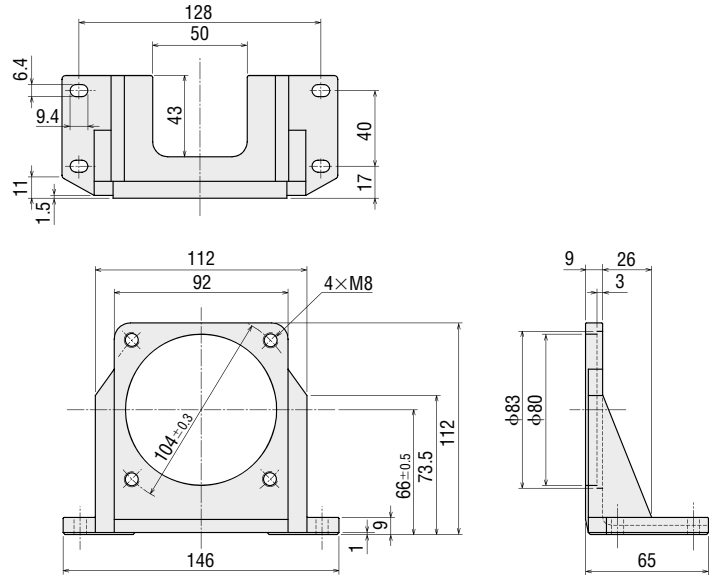

PLA60G

Mass: 0.7 kg

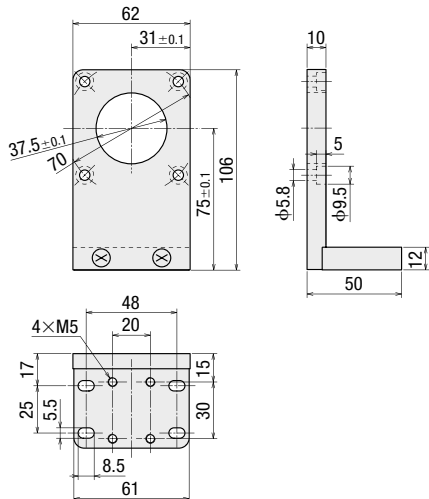

● Mounting Screws: M5 Length 15 mm
Included 4 pieces

PLA60H

Mass: 0.7 kg

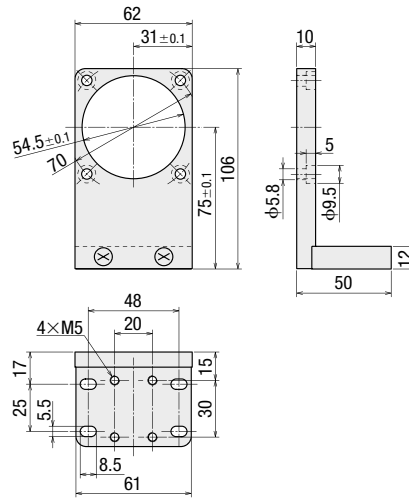

● Mounting Screws: M5 Length 15 mm
Included 4 pieces

PLA90G

Mass: 1.6 kg

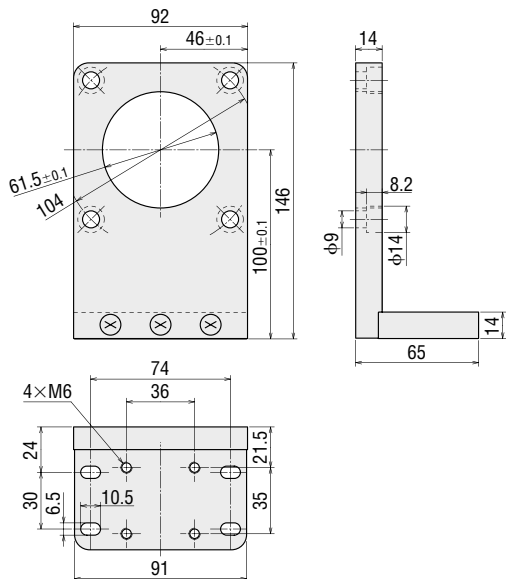

● Mounting Screws: M6 Length 20 mm
Included 4 pieces

PLA90H

Mass: 1.6 kg

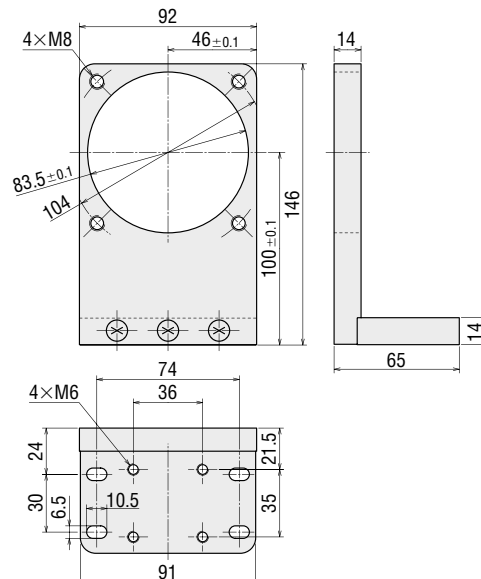

● Mounting Screws: M8 Length 30 mm
Included 4 pieces, 4 washers

Regeneration Unit

During vertical drive (gravitational operation) or sudden start/stop in high inertia, an external force causes the motor to rotate and function as a power generator. When the regenerative power exceeds the driver's regenerative power absorption capacity, it may cause damage to the motor.

In such a case, the regeneration unit has to be connected to the driver to convert regenerative energy into thermal energy for dissipation.



Product Line

Product Name	List Price
RGB100	45.00 €

Specifications

Item	Description
Continuous Regenerative Power	50 W
Resistance Value	150 Ω
Thermostat Operating Temperature	Open: 150±7°C Close: 145±12°C (Normally closed)
Thermostat Electrical Rating	120 VAC 4 A 30 VDC 4 A (Min. current 5 mA)

- Attach the regeneration unit to a location that has the same heat radiation capability as an aluminum heat radiation plate that is 350x350 mm and 3 mm thick.

Network Converters

Network converter is a transducer from the host communication protocol to our unique RS-485 communication protocol. By using this network converter, our RS-485 compatible products can be controlled under host communication environment.

Product Line

Network	Product Name
CC-Link Ver. 1.1 Compatible	NETC01-CC
CC-Link Ver. 2 Compatible	NETC02-CC
MECHATROLINK-II Compatible	NETC01-M2
MECHATROLINK-III Compatible	NETC01-M3
EtherCAT Compatible	NETC01-ECT



Controllers

Equipped with program editing and execution functions, the highly-functional and sophisticated **SCX11** controller is available. Use the **SCX11** as a stored program controller to connect to any of Oriental Motor's standard pulse input drivers.

The **SCX11** is also able to control the motor via various serial ports such as USB, RS-232C and **CANopen**.

- 100 Sequence Programs can be Stored
- Easy Operation
- Intelligent Setting

Product Line

Product Name	Driver Product Name
SCX11	AZD-C, AZD-K, AZD-CX, AZD-KX



Features

System Configuration

Product Line

Specifications and Features

Dimensions

Connection and Operation

System Configuration

Product Line

Specifications and Features

Dimensions

Connection and Operation

Multiaxis Driver

Accessories

Orientalmotor

These products are manufactured at plants certified with the international standards **ISO 9001** (for quality assurance) and **ISO 14001** (for systems of environmental management).

Specifications are subject to change without notice. This catalogue was published in June 2022.

ORIENTAL MOTOR (EUROPA) GmbH

www.orientalmotor.de

European Headquarters

Schießstraße 44
40549 Düsseldorf, Germany
Tel: 0211-520 670 0 Fax: 0211-520 670 99



Spanish Office

C/Caléndula 93 - Ed. E - Miniparc III
28109 El Soto de La Moraleja,
Alcobendas (Madrid), Spain
Tel: +34 918 266 565
www.orientalmotor.es

ORIENTAL MOTOR (UK) LTD.

www.oriental-motor.co.uk

UK Headquarters

Unit 5, Faraday Office Park,
Rankine Road, Basingstoke,
Hampshire RG24 8AH, U.K.
Tel: 01256-347 090 Fax: 01256-347 099



ORIENTAL MOTOR SWITZERLAND AG

www.orientalmotor.ch

Switzerland Headquarters

Badenerstraße 13
5200 Brugg AG, Switzerland
Tel: 056-560 504 5 Fax: 056-560 504 7



ORIENTAL MOTOR ITALIA s.r.l.

www.orientalmotor.it

Italy Headquarters

Via XXV Aprile 5
20016 Pero (MI), Italy
Tel: 02-939 063 46 Fax: 02-939 063 48



ORIENTAL MOTOR (FRANCE) SARL

www.orientalmotor.fr

France Headquarters

56, Rue des Hautes Pâtures
92000 Nanterre, France
Tel: 01-478 697 50 Fax: 01-478 245 16



Other countries: www.orientalmotor.eu

Customer Service Center (Support in German & English)

00800-22 55 66 22*
CA LL OM CC

Mon-Thu: 08:00 - 17:30 CET Friday: 08:00 - 16:00 CET

* Free Call Europe

info@orientalmotor.de

For more information please contact: