

1.8°, 0.72° and 0.36°
Stepper Motor and Driver Package

CVK Series

DC Input

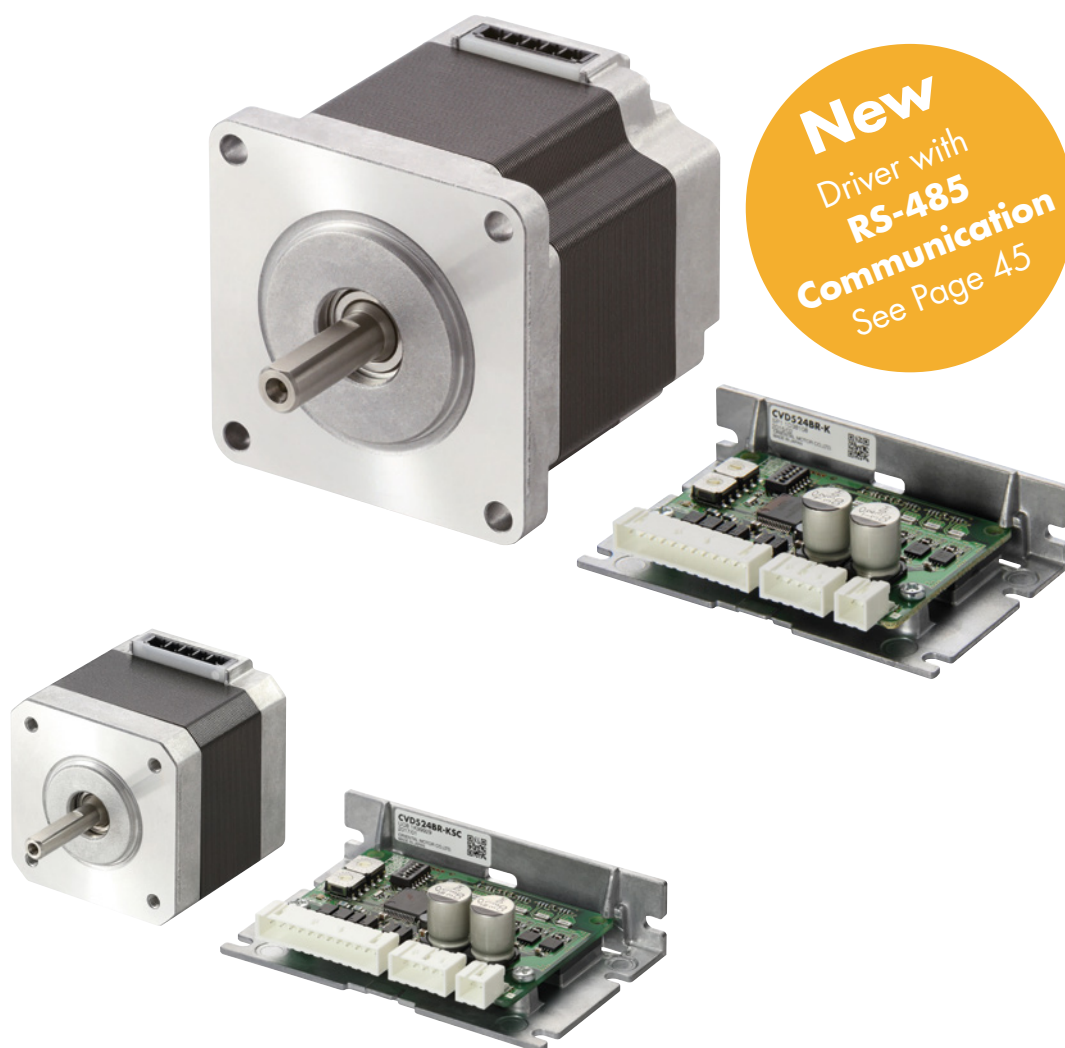

The **CVK Series** is a stepper motor and driver package designed for guaranteed performance. The motor product line-up includes a 1.8°, 0.72° or 0.36° stepper motor and driver with virtually identical frame sizes.

The drivers are compatible in terms of functionality, operation method and installation.

Furthermore, the prices of the 1.8° and 0.72°/0.36° stepper motor and driver packages are similar, making them both affordable and attractive.

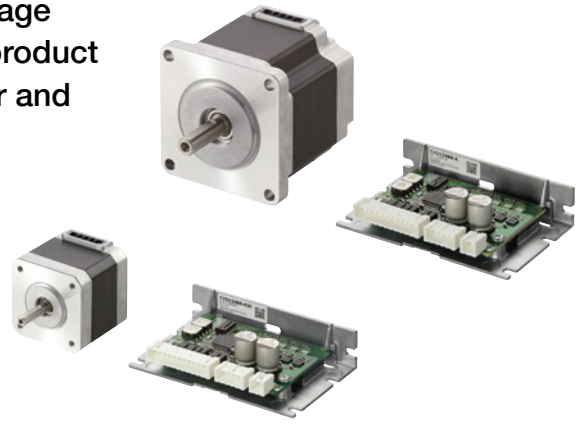

Features

1.8° Stepper Motor and 0.72°/0.36° Stepper Motor CVK Series with Improved Basic Performance

● 1.8° Stepper Motor with Higher Torque and Less Vibration in the Low Speed Range

High current is possible thanks to the revised motor winding design and the highly efficient design of the drive circuit, and the torque has been increased significantly at low speeds. In particular, the torque at around 250 r/min is 50% higher than that of a conventional product. In addition, the motor vibrates less and produces less noise than a typical 1.8° stepper motor. This product consists of the 1.8° stepper motor and bipolar driver with improved overall basic performance.

◇ Higher Torque in the Low Speed Range

The maximum holding torque has been increased by bipolar wiring.

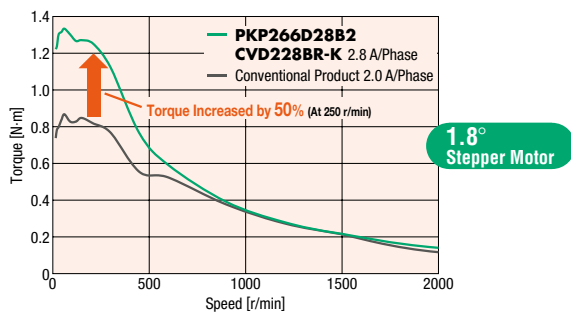

● 0.72°/0.36° Stepper Motor with Higher Torque and Reduced Vibration and Noise at All Speeds

The performance of the 0.72°/0.36° stepper motor has been maximized thanks to the revised motor winding design and the highly efficient design of the drive circuit, and the torque has been increased significantly at all speeds. In addition, this product consists of the high-performance 0.72°/0.36° stepper motor and bipolar driver, which acts as a digitally-controlled full-time microstep driver to reduce vibration and noise, compared to conventional products.

◇ Higher Torque at All Speeds

Making the motor winding suitable for high currents expands the usage potential significantly.

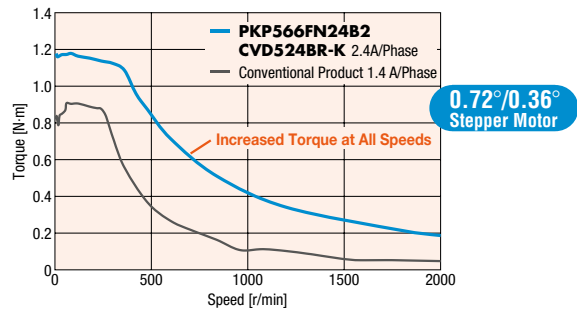

◇ Low Vibration

Utilizing a digitally-controlled full-time microstep driver improves the vibration at all speeds.

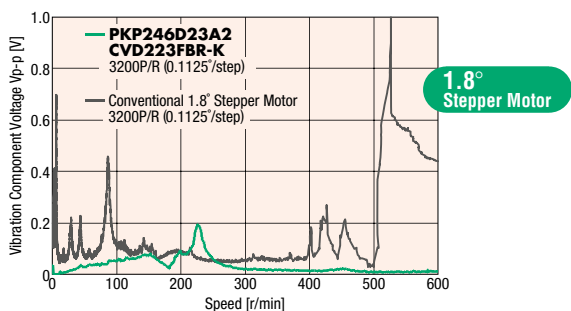

◇ Lower Vibration and Reduced Noise

Utilizing a digitally-controlled full-time microstep driver reduces both vibration and noise.

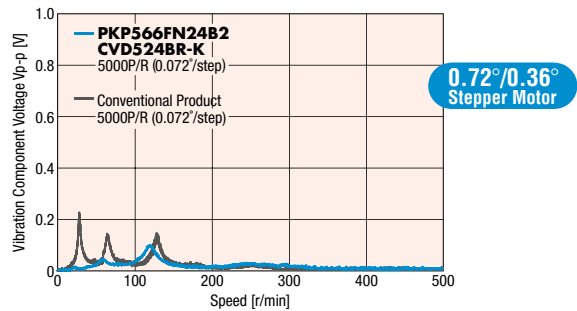

1.8° Stepper Motor Focuses on High Torque at Low Speeds. 0.72°/0.36° Stepper Motor Focuses on Low Vibration and High Positioning Accuracy.

● The Torque has been Increased Significantly. More Applications for High Torque.

With higher currents, the maximum holding torque at low speeds for the 1.8° stepper motor **CVK** Series and the torque at high speeds or the 0.72°/0.36° stepper motor **CVK** Series have been increased significantly. More motor selections are available, so a motor that matches your desired specifications can be selected from a wide range of speed and torque variations.

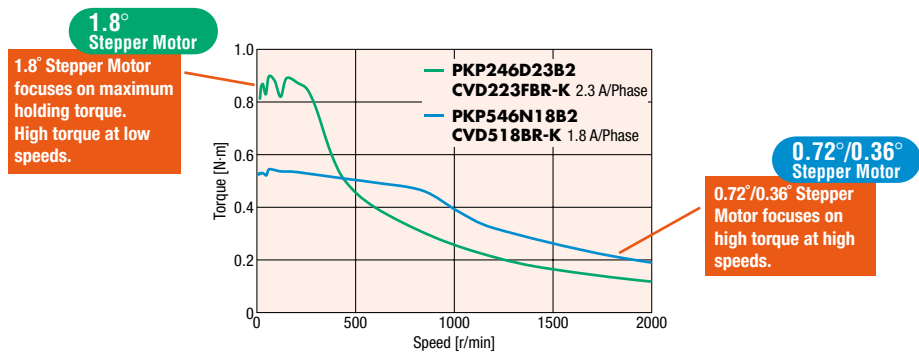

● Low Vibration Achieved by Full-Time Microstep Drive

Utilizing a digitally-controlled full-time microstep driver improves the vibration levels and reduces both vibration and noise at all speeds. The 0.72°/0.36° stepper motor **CVK** Series has the superior vibration characteristics.

- **Reduction in Step Vibration**
 The new smooth drive control with its increased current control resolution allows the basic step angle to be divided into a max. of 2048 microstep angles. This has greatly reduced the step vibration at low speeds.

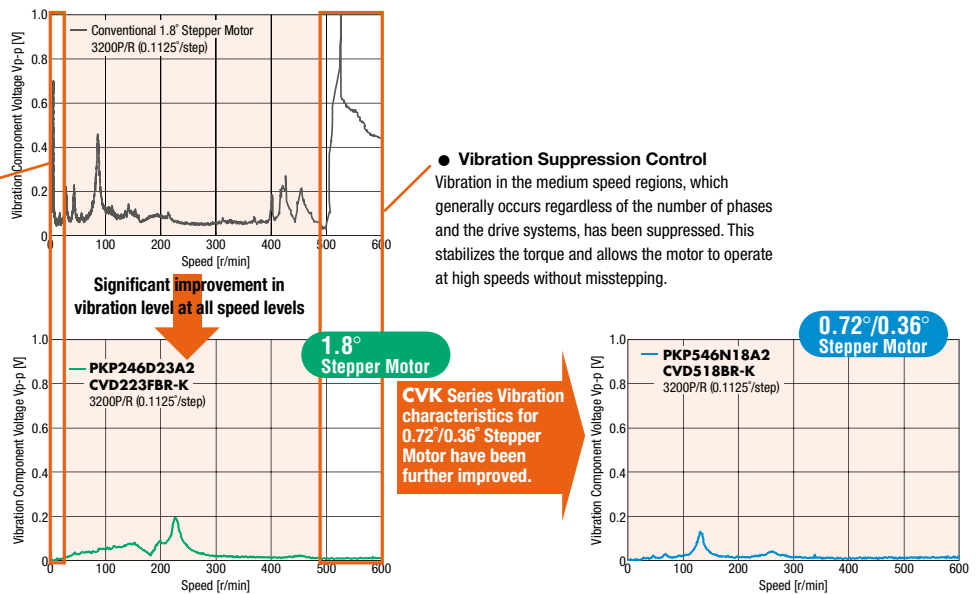

● 0.72°/0.36° Stepper Motor for High Accuracy Positioning

The resolution can be set to a maximum of 125000 P/R via the full-time microstep drive. Stopping accuracy generally drops when using the full-time microstep drive, as compared to a full-step type drive, especially with the 1.8° stepper motor. In such cases, using the 0.72°/0.36° stepper motor **CVK** Series can result in greater positioning accuracy.

◇ General 1.8° Stepper Motor

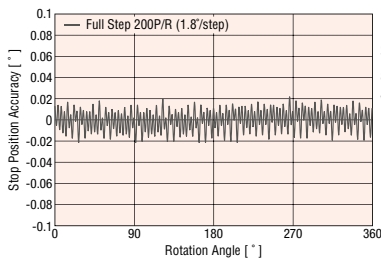

◇ 0.72°/0.36° Stepper Motor

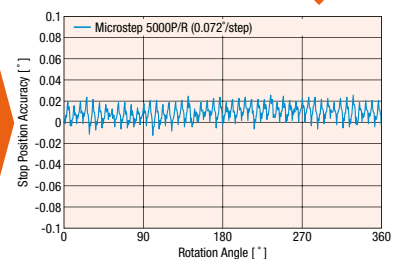
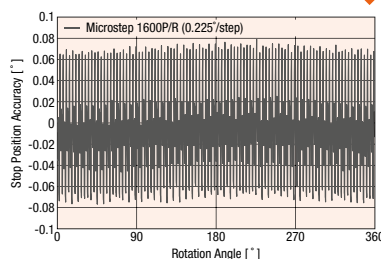
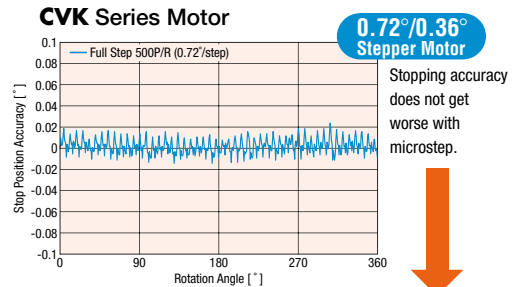

- **Stopping accuracy**
 0.72° Stepper Motor $\pm 0.05^\circ$ (± 3 arc minutes)
 0.36° Stepper Motor $\pm 0.034^\circ$ (± 2 arc minutes)

Providing the Freedom to Choose between 1.8° Stepper Motor and 0.72°/0.36° Stepper Motor

● Freely Evaluate from 1.8° Stepper Motor to 0.72°/0.36° Stepper Motor or from 0.72°/0.36° Stepper Motor to 1.8° Stepper Motor

The drivers in the 1.8° stepper motor and 0.72°/0.36° stepper motor **CVK Series** are similar in size, installation and I/O connectors. This allows you to select 1.8° stepper motor or 0.72°/0.36° stepper motor according to your required specifications and evaluate them. In addition, the motors are among the best in the industry for compactness and lightness.

- A driver cannot be shared by both a 1.8° stepper motor and 0.72°/0.36° stepper motor. Each uses a respective dedicated driver.

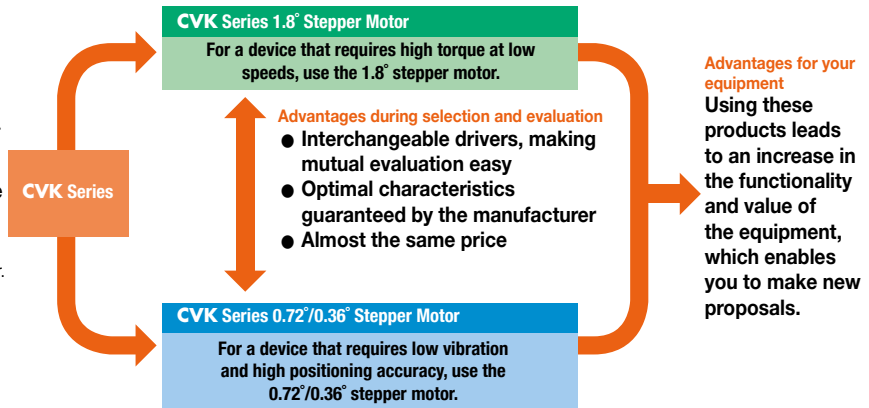

● Industry's-Top-Class Compact High Performance Driver

- Compact and lightweight drivers that contribute to saving space
- Protective function that enables you to find driver errors early
- Smooth drive function that enables smoother operation
- Set the running current using a digital switch

● Functions and Names of Driver Parts

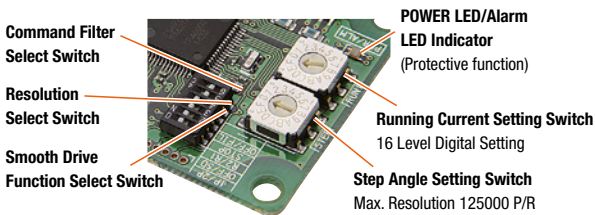

Actual Size

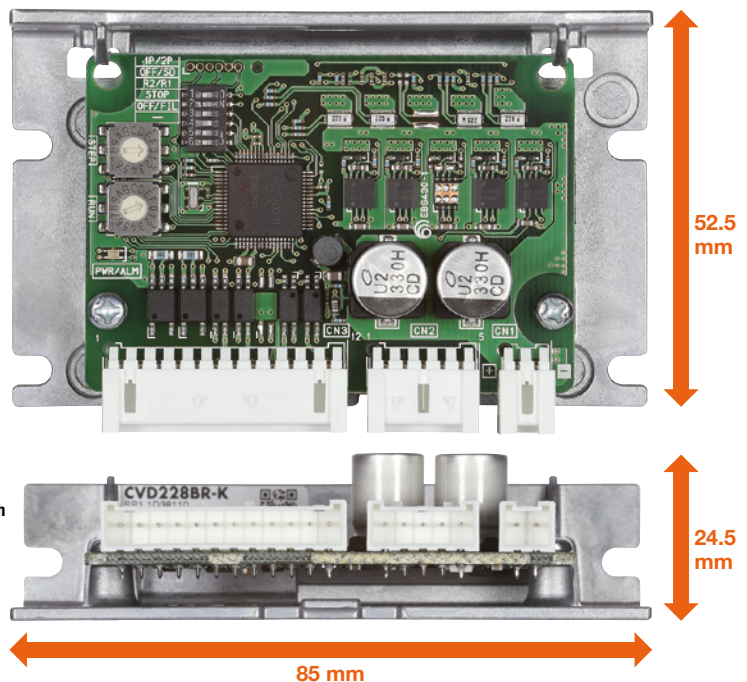

● 2 Types of Drivers are Available.

2 types of drivers are provided for both 1.8° stepper motor and 0.72°/0.36° stepper motor.

- Right Angle Type with Installation Plate
The connector points outward.
- With Installation Plate
The connector points upward.

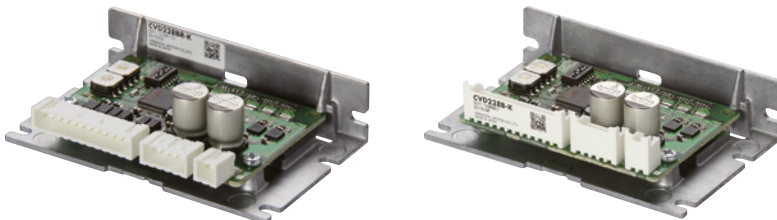

- A driver cannot be shared by both a 1.8° stepper motor and 0.72°/0.36° stepper motor. Each uses a respective dedicated driver.
- A type without an installation plate is also available. For details, please contact your nearest Oriental Motor sales office.

● The Price of the 1.8° Stepper Motor and 0.72°/0.36° Stepper Motor is Almost the Same.

















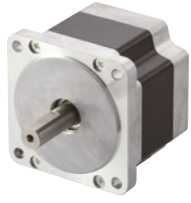













In the **CVK Series**, in addition to the performance and functionality being significantly improved, the prices have been revised. There is only a slight price difference between the 1.8° stepper motor and 0.72°/0.36° stepper motor, and both of them are offered at affordable prices.

● Comparison between 1.8° Stepper Motor and 0.72°/0.36° Stepper Motor



Product Line

-: Not Offered in This Product Line

Type	Basic Step Angle	Frame Size							Driver
		20 mm	28 mm	35 mm	42 mm	56.4 mm	60 mm	85 mm	
Standard Type	1.8°	 					-	 	 Driver for 1.8° Stepper Motor
	0.72°			-				 	
High-Resolution Type	0.36°	-	-	-		-		-	
Standard Type with Encoder	1.8°	 		-			-	-	 Driver for 0.72°/0.36° Stepper Motor
	0.72°		-	-				-	
SH Geared Type	0.5° ~ 0.05°	-		-		-		-	

● A driver cannot be shared by both a 1.8° stepper motor and 0.72°/0.36° stepper motor. Each uses a respective dedicated driver.

Motor Types

Standard Type

This is an easy-to-use basic model. Some products use a slim and compact connector, so the overhang distance of the connector becomes shorter. In addition, the degree of freedom for the cable direction has been increased, because the outlet points upward. [Basic Step Angle] 1.8°/step, 0.72°/step



High-Resolution Type (0.36° Stepper Motor)

This motor's basic resolution is double that of the standard type. The slight displacement angle against the load torque provides high positioning accuracy. Vibration is also reduced. [Basic Step Angle] 0.36°/step



Standard Type with Encoder

Using a motor with an encoder enables operations such as monitoring the current position and detecting positional errors. Doing this increases the reliability of the equipment. [Basic Step Angle] 1.8°/step, 0.72°/step



SH Geared Type (For 1.8° Stepper Motor)

This type is well-suited for deceleration, increased torque, high resolution, and limited vibration. There is less backlash than you get with the conventional product. [Basic Step Angle] 0.5 ~ 0.05°/step



System Configuration

An example of a system configuration with the **SCX11** controller is shown below.

* Not supplied.

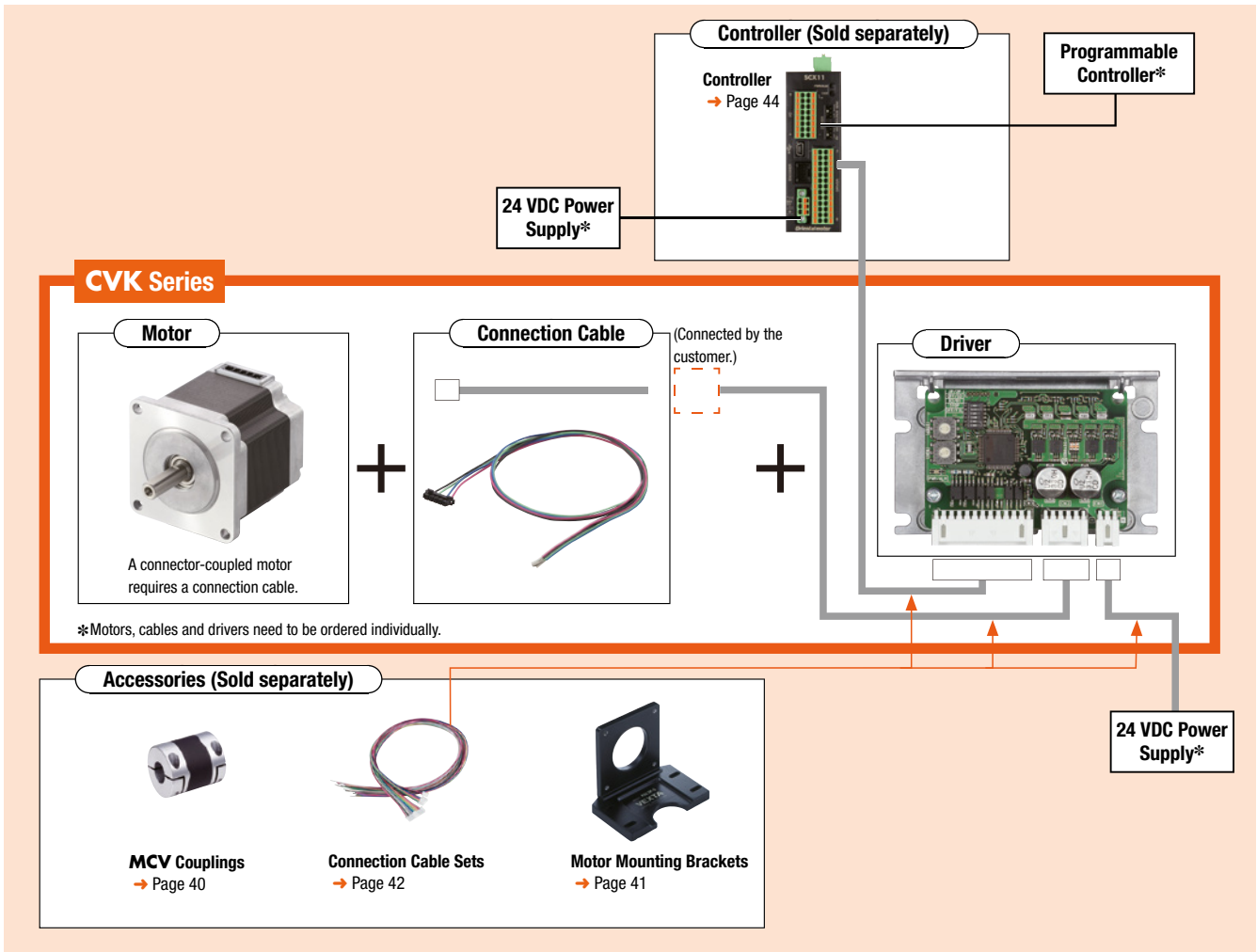

Example of System Configuration

CVK Series			Accessory			
Motor	Connection Cable	Driver	Controller	Motor Mounting Bracket	Flexible Coupling	Connection Cable Set (0.6 m)
PKP266D28A2	LC2B06E	CVD228BR-K	SCX11	PAL2P-2	MCV190808	LCSO1CVK2
€42.00	€5.00	€105.00	€215.00	€13.00	€48.00	€18.00

The system configuration shown above is an example. Other combinations are also available.

Product Number

Motor

◇ 1.8° Stepper Motor

Standard Type

PKP 2 6 6 D 28 A 2

① ② ③ ④ ⑤ ⑥ ⑦ ⑧

Standard Type with Encoder

PKP 2 4 3 D 15 A 2 - R2E L

① ② ③ ④ ⑤ ⑥ ⑦ ⑧ ⑨ ⑩

①	Series Name	PKP: PKP Series
②	2: 1.8° Stepper Motor	
③	Motor Frame Size	1: 20 mm 2: 28 mm 3: 35 mm 4: 42 mm 6: 56.4 mm 9: 85 mm
④	Motor Case Length	
⑤	Number of Lead Wires	D: 4 Leads
⑥	Motor Winding Specifications	
⑦	Configuration	A: Single Shaft B: Double Shaft
⑧	Reference Number	
⑨	Encoder Resolution	R2E: 200 P/R R2F: 400 P/R
⑩	Encoder Output Circuit Type	L: Line Driver Output*

*A voltage output type of encoder output circuit is also available.
For details, please contact your nearest Oriental Motor sales office.

SH Geared Type

PKP 2 4 3 D 23 B 2 - SG 18

① ② ③ ④ ⑤ ⑥ ⑦ ⑧ ⑨ ⑩

◇0.72°/0.36° Stepper Motor

Frame Size 20 mm, 85 mm

Standard Type

PK 5 1 3 P A

① ② ③ ④ ⑤ ⑧

PK 5 9 6 H N A W

① ② ③ ④ ⑥ ⑦ ⑧ ⑪

Standard Type with Encoder

PK 5 1 3 P A - R2G L

① ② ③ ④ ⑤ ⑧ ⑨ ⑩

Frame Size 28 mm, 42 mm, 56.4 mm, 60 mm

Standard Type, High-Resolution Type

PKP 5 6 6 F N 24 A 2

① ② ③ ④ ⑤ ⑦ ⑧ ⑨ ⑩

PKP 5 4 4 M N 18 A

① ② ③ ④ ⑥ ⑦ ⑧ ⑨

Standard Type with Encoder

PKP 5 6 6 F N 24 A 2 - R2G L

① ② ③ ④ ⑤ ⑦ ⑧ ⑨ ⑩ ⑪ ⑫

①	Series Name	PKP: PKP Series
②	2: 1.8° Stepper Motor	
③	Motor Frame Size	2: 28 mm 4: 42 mm 6: 60 mm
④	Motor Case Length	
⑤	Number of Lead Wires	D: 4 Leads
⑥	Motor Winding Specifications	
⑦	Configuration	A: Single Shaft B: Double Shaft
⑧	Reference Number	
⑨	Geared Type	SG: SH Geared Type
⑩	Gear Ratio	

①	Series Name	PK: PK Series
②	5: 0.72°/0.36° Stepper Motor	
③	Motor Frame Size	1: 20 mm 9: 85 mm
④	Motor Case Length	
⑤	Motor Classification	
⑥	Motor Specification	Blank: Standard Specifications H: High-Speed Specifications
⑦	Number of Lead Wires	N: 5 Leads
⑧	Configuration	A: Single Shaft B: Double Shaft
⑨	Encoder Resolution	R2G: 500 P/R
⑩	Encoder Output Circuit Type	L: Line Driver Output
⑪	Cable Identification	Blank: Connector Connection Method W: Lead Wire Type

①	Series Name	PKP: PKP Series
②	5: 0.72°/0.36° Stepper Motor	
③	Motor Frame Size	2: 28 mm 4: 42 mm 6: 56.4 mm (60 mm when the motor classification is "F")
④	Motor Case Length	
⑤	Motor Classification	F: Motor Frame Size of 60 mm
⑥	Motor Type	Blank: Standard Type M: High-Resolution Type
⑦	Number of Lead Wires	N: 5 Leads
⑧	Motor Winding Specifications	
⑨	Configuration	A: Single Shaft B: Double Shaft
⑩	Reference Number	
⑪	Encoder Resolution	R2G: 500 P/R
⑫	Encoder Output Circuit Type	L: Line Driver Output*

*A voltage output type of encoder output circuit is also available.
For details, please contact your nearest Oriental Motor sales office.

● Driver

CVD 2 23 F B R - K

① ② ③ ④ ⑤ ⑥ ⑦

①	Driver Type	CVD: CVK Series Driver
②		2: 1.8° Stepper Motor 5: 0.72°/0.36° Stepper Motor
③	Rated Current	
④	Driver Identification	
⑤	Driver Configuration	B: With Installation Plate*
⑥	Connector Configuration	R: Right Angle
⑦	Power Supply Input	K: DC Power Supply

*Types without an installation plate are available.
For details, please contact your nearest Oriental Motor sales office.

● Connection Cable

◇ Connection Cable for Motor

LC 2 B 06 A

① ② ③ ④ ⑤

①	Cables	LC: Connector-Type Leads
②		2: 1.8° Stepper Motor 5: 0.72°/0.36° Stepper Motor
③	Cable Type	B: For 1.8° Stepper Motor Bipolar N: For 0.72°/0.36° Stepper Motor
④	Cable Length	06: 0.6 m 10: 1 m
⑤	Reference Number	

◇ Connection Cable for Encoder

LC E 08 A - 006

① ② ③ ④ ⑤

①	Cables	LC: Connector Leads
②	Cable Type	E: For Encoder
③	Applicable Models	08: For Line Driver Output*
④	Reference Number	
⑤	Cable Length	006: 0.6 m

*A voltage output cable is available.
For details, please contact your nearest Oriental Motor sales office.

■ Product Line

● Motor

◇ 1.8° Stepper Motor

● Standard Type

Product Name (Single Shaft)	List Price	Product Name (Double Shaft)	List Price
PKP213D05A	€44.00	PKP213D05B	€46.00
PKP214D06A	€47.00	PKP214D06B	€49.00
PKP223D15A2	€30.00	PKP223D15B2	€32.00
PKP225D15A2	€36.00	PKP225D15B2	€38.00
PKP233D23A	€30.00	PKP233D23B	€32.00
PKP235D23A	€36.00	PKP235D23B	€38.00
PKP243D23A2	€30.00	PKP243D23B2	€32.00
PKP244D23A2	€32.00	PKP244D23B2	€34.00
PKP245D23A2	€36.00	PKP245D23B2	€38.00
PKP246D23A2	€38.00	PKP246D23B2	€40.00
PKP264D28A2	€38.00	PKP264D28B2	€40.00
PKP266D28A2	€42.00	PKP266D28B2	€44.00
PKP268D28A2	€52.00	PKP268D28B2	€54.00
PKP296D45A	€89.00	PKP296D45B	€96.00
PKP299D45A	€137.00	PKP299D45B	€144.00
PKP2913D45A	€173.00	PKP2913D45B	€180.00

● Standard Type with Encoder

Product Name	List Price
PKP213D05A-R2EL	€94.00
PKP214D06A-R2EL	€97.00
PKP223D15A2-R2EL	€80.00
PKP225D15A2-R2EL	€86.00
PKP243D23A2-R2EL	€80.00
PKP243D23A2-R2FL	€80.00
PKP244D23A2-R2EL	€82.00
PKP244D23A2-R2FL	€82.00
PKP245D23A2-R2EL	€86.00
PKP245D23A2-R2FL	€86.00
PKP246D23A2-R2EL	€88.00
PKP246D23A2-R2FL	€88.00
PKP264D28A2-R2EL	€88.00
PKP264D28A2-R2FL	€88.00
PKP266D28A2-R2EL	€92.00
PKP266D28A2-R2FL	€92.00
PKP268D28A2-R2EL	€102.00
PKP268D28A2-R2FL	€102.00

● SH Geared Type

Product Name (Single Shaft)	List Price	Product Name (Double Shaft)	List Price
PKP223D15A-SG7.2	€90.00	PKP223D15B-SG7.2	€92.00
PKP223D15A-SG9	€90.00	PKP223D15B-SG9	€92.00
PKP223D15A-SG10	€90.00	PKP223D15B-SG10	€92.00
PKP223D15A-SG18	€105.00	PKP223D15B-SG18	€107.00
PKP223D15A-SG36	€105.00	PKP223D15B-SG36	€107.00
PKP243D23A2-SG3.6	€90.00	PKP243D23B2-SG3.6	€92.00
PKP243D23A2-SG7.2	€90.00	PKP243D23B2-SG7.2	€92.00
PKP243D23A2-SG9	€90.00	PKP243D23B2-SG9	€92.00
PKP243D23A2-SG10	€90.00	PKP243D23B2-SG10	€92.00
PKP243D23A2-SG18	€105.00	PKP243D23B2-SG18	€107.00
PKP243D23A2-SG36	€105.00	PKP243D23B2-SG36	€107.00
PKP264D28A2-SG3.6	€108.00	PKP264D28B2-SG3.6	€110.00
PKP264D28A2-SG7.2	€108.00	PKP264D28B2-SG7.2	€110.00
PKP264D28A2-SG9	€108.00	PKP264D28B2-SG9	€110.00
PKP264D28A2-SG10	€108.00	PKP264D28B2-SG10	€110.00
PKP264D28A2-SG18	€118.00	PKP264D28B2-SG18	€120.00
PKP264D28A2-SG36	€118.00	PKP264D28B2-SG36	€120.00

◇ 0.72°/0.36° Stepper Motor

● Standard Type

Product Name (Single Shaft)	List Price	Product Name (Double Shaft)	List Price
PKP513PA	€93.00	PKP513PB	€97.00
PKP523N12A	€35.00	PKP523N12B	€37.00
PKP525N12A	€41.00	PKP525N12B	€43.00
PKP543N18A2	€35.00	PKP543N18B2	€37.00
PKP544N18A2	€37.00	PKP544N18B2	€39.00
PKP545N18A2	€41.00	PKP545N18B2	€43.00
PKP546N18A2	€43.00	PKP546N18B2	€45.00
PKP564N28A2	€43.00	PKP564N28B2	€45.00
PKP566N28A2	€47.00	PKP566N28B2	€49.00
PKP568N28A2	€59.00	PKP568N28B2	€61.00
PKP564FN24A2	€47.00	PKP564FN24B2	€49.00
PKP564FN38A2	€47.00	PKP564FN38B2	€49.00
PKP566FN24A2	€51.00	PKP566FN24B2	€53.00
PKP566FN38A2	€51.00	PKP566FN38B2	€53.00
PKP569FN24A2	€63.00	PKP569FN24B2	€65.00
PKP569FN38A2	€63.00	PKP569FN38B2	€65.00
PK596HNAW	€107.00	PK596HNBW	€110.00
PK599HNAW	€142.00	PK599HNBW	€146.00
PK5913HNAW	€178.00	PK5913HNBW	€185.00

● High-Resolution Type

Product Name (Single Shaft)	List Price	Product Name (Double Shaft)	List Price
PKP544MN18A	€37.00	PKP544MN18B	€39.00
PKP546MN18A	€43.00	PKP546MN18B	€45.00
PKP564FMN24A	€47.00	PKP564FMN24B	€49.00
PKP566FMN24A	€51.00	PKP566FMN24B	€53.00
PKP569FMN24A	€63.00	PKP569FMN24B	€65.00

● Bipolar Driver for 1.8° Stepper Motor

◇ Right Angle Type with Installation Plate

Product Name	List Price
CVD205BR-K	€105.00
CVD206BR-K	
CVD215BR-K	
CVD223BR-K	
CVD223FBR-K	
CVD228BR-K	
CVD245BR-K	€120.00

◇ With Installation Plate

Product Name	List Price
CVD205B-K	€105.00
CVD206B-K	
CVD215B-K	
CVD223B-K	
CVD223FB-K	
CVD228B-K	
CVD245B-K	€120.00

● Driver for 0.72°/0.36° Stepper Motor

◇ Right Angle Type with Installation Plate

Product Name	List Price
CVD503BR-K	€115.00
CVD512BR-K	
CVD518BR-K	
CVD524BR-K	€130.00
CVD528BR-K	
CVD538BR-K	

◇ With Installation Plate

Product Name	List Price
CVD503B-K	€115.00
CVD512B-K	
CVD518B-K	
CVD524B-K	€130.00
CVD528B-K	
CVD538B-K	

● Standard Type with Encoder

Product Name	List Price
PK513PA-R2GL	€147.00
PKP543N18A2-R2GL	€85.00
PKP544N18A2-R2GL	€87.00
PKP545N18A2-R2GL	€91.00
PKP546N18A2-R2GL	€93.00
PKP564N28A2-R2GL	€93.00
PKP566N28A2-R2GL	€97.00
PKP568N28A2-R2GL	€109.00
PKP564FN24A2-R2GL	€97.00
PKP564FN38A2-R2GL	€97.00
PKP566FN24A2-R2GL	€101.00
PKP566FN38A2-R2GL	€101.00
PKP569FN24A2-R2GL	€113.00
PKP569FN38A2-R2GL	€113.00

● As an accessory for DC input drivers, lead wires with a connector are available. These lead wires allow for easy connection of the motor, power supply and input/output signals. The connection cable set includes three connection cables (for motor, power supply and input/output signals).

● Connection Cable for Motors

◇ For 1.8° Stepper Motor

Product Name	Length L (m)	List Price
LC2B06A	0.6	€5.00
LC2B06B	0.6	
LC2B06E	0.6	

◇ For 0.72°/0.36° Stepper Motor

Product Name	Length L (m)	List Price
LC5N06A	0.6	€5.00
LC5N10A	1	€7.00
LC5N06B	0.6	€5.00
LC5N10B	1	€7.00
LC5N06C	0.6	€7.00
LC5N10C	1	€9.00
LC5N06E	0.6	€5.00

● Connection Cable for Encoders

◇ For Line Driver Output

Product Name	Length L (m)	List Price
LCE08A-006	0.6	€10.00

■ Included

● Motor

Type	Included	Operating Manual
Common to All Types		1 Set

● Driver

Type	Included	Connector	Operating Manual
Common to All Types		For CN1 (1 Piece) For CN2 (1 Piece) For CN3 (1 Piece)	1 Set

Frame Size 20 mm, 28 mm

1.8° Stepper Motor and Driver Package: Standard Type/Standard Type with Encoder

Specifications



Motor Product Name	Single Shaft	PKP213D05A	PKP214D06A	PKP223D15A2	PKP225D15A2
	Double Shaft	PKP213D05B	PKP214D06B	PKP223D15B2	PKP225D15B2
	With Encoder	PKP213D05A-R2EL	PKP214D06A-R2EL	PKP223D15A2-R2EL	PKP225D15A2-R2EL
Driver Product Name		CVD205B□-K	CVD206B□-K	CVD215B□-K	CVD215B□-K
Maximum Holding Torque	N·m	0.02	0.036	0.095	0.19
Holding Torque at Motor Standstill	N·m	0.01	0.018	0.047	0.095
Rotor Inertia	J: kg·m ²	1.6×10 ⁻⁷ [1.66×10 ⁻⁷]	2.9×10 ⁻⁷ [2.96×10 ⁻⁷]	9×10 ⁻⁷	18×10 ⁻⁷
Rated Current	A / Phase	0.5	0.6	1.5	
Basic Step Angle		1.8°			
Power Supply Input		24 VDC±10% 0.5 A		24 VDC±10% 1.3 A	
Excitation Mode		Microstep			

● Encoder Specifications → Page 26

● For the right angle type with an installation plate, an **R** (right angle) indicating the connector configuration is specified where the box □ is located in the product name.

● The brackets [] indicate the specifications for the type with an encoder.

Speed – Torque Characteristics (Reference values)

PKP213

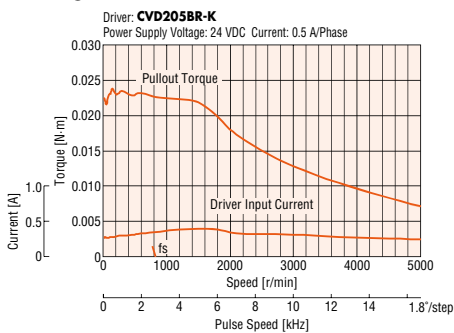

PKP214

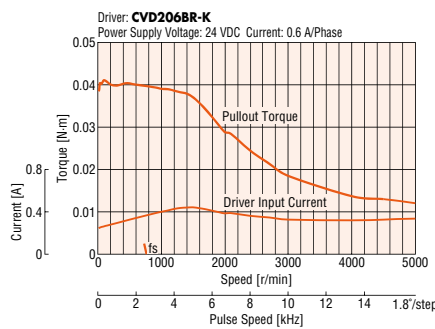

PKP223

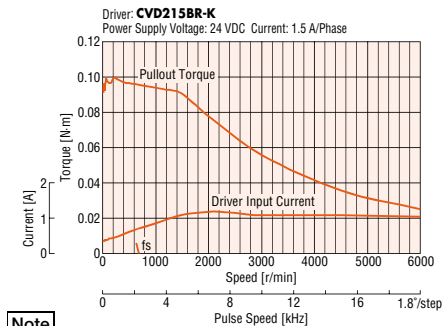

PKP225

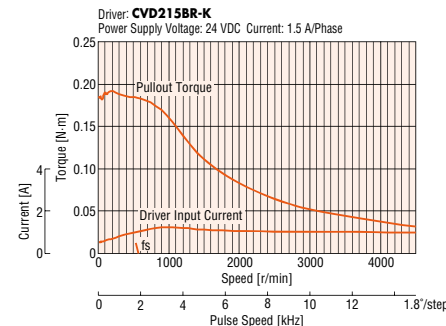

Note

● Data for the speed – torque characteristics is based on Oriental Motor's internal measurement conditions. If the conditions are changed, the characteristics may also change as a result.

● Depending on the driving conditions, a considerable amount of heat may be generated by the motor. Be sure to keep the motor case temperature at 100°C or less. For the type with an encoder, to protect the encoder, be sure to keep the motor case temperature at 85°C max.

Explanation of Terms in Specifications Table

Maximum Holding Torque	The maximum holding torque (holding force) the motor has when power (rated current) is being supplied but the motor shaft is at standstill. (With geared types, the value of holding torque considers the permissible strength of the gear.)	
Permissible Torque	This is the maximum torque continuously applied to the gear output shaft.	
Max. Instantaneous Torque	This is the maximum torque that can be applied to the gear output shaft during acceleration/deceleration, such as when an inertial load is started and stopped.	
Holding Torque at Motor Standstill	When Power is ON	This is the holding torque when the automatic current cutback function is activated.
	Electromagnetic Brake	This is the static friction torque that the electromagnetic brake can generate at rest. (Electromagnetic brake is power off activated type.)

Frame Size 35 mm

1.8° Stepper Motor and Driver Package: Standard Type

Specifications



Motor Product Name	Single Shaft	PKP233D23A	PKP235D23A
	Double Shaft	PKP233D23B	PKP235D23B
Driver Product Name		CVD223B <input type="checkbox"/> -K	CVD223B <input type="checkbox"/> -K
Maximum Holding Torque	N·m	0.2	0.37
Holding Torque at Motor Standstill	N·m	0.1	0.19
Rotor Inertia	J: kg·m ²	24×10 ⁻⁷	50×10 ⁻⁷
Rated Current	A / Phase	2.3	
Basic Step Angle		1.8°	
Power Supply Input		24 VDC ±10% 2.0 A	
Excitation Mode		Microstep	

● For the right angle type with an installation plate, an **R** (right angle) indicating the connector configuration is specified where the box is located in the product name.

Speed – Torque Characteristics (Reference values)

PKP233

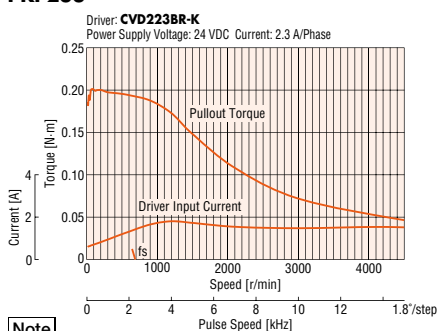

PKP235

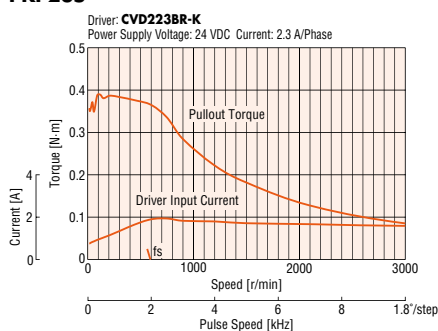

Note

- Data for the speed – torque characteristics is based on Oriental Motor's internal measurement conditions. If the conditions are changed, the characteristics may also change as a result.
- Depending on the driving conditions, a considerable amount of heat may be generated by the motor. Be sure to keep the motor case temperature at 100°C or less.

Frame Size 42 mm

1.8° Stepper Motor and Driver Package: Standard Type/Standard Type with Encoder

Specifications



Motor Product Name	Single Shaft	PKP243D23A2	PKP244D23A2	PKP245D23A2	PKP246D23A2	
	Double Shaft	PKP243D23B2	PKP244D23B2	PKP245D23B2	PKP246D23B2	
	With Encoder	PKP243D23A2-R2EL PKP243D23A2-R2FL	PKP244D23A2-R2EL PKP244D23A2-R2FL	PKP245D23A2-R2EL PKP245D23A2-R2FL	PKP246D23A2-R2EL PKP246D23A2-R2FL	
Driver Product Name	CVD223FB□-K		CVD223FB□-K		CVD223FB□-K	
Maximum Holding Torque	N·m	0.35	0.48	0.66	0.99	
Holding Torque at Motor Standstill	N·m	0.18	0.24	0.33	0.5	
Rotor Inertia	J: kg·m ²	36×10 ⁻⁷	54×10 ⁻⁷	73×10 ⁻⁷	110×10 ⁻⁷	
Rated Current	A / Phase	2.3				
Basic Step Angle		1.8°				
Power Supply Input		24 VDC±10% 2.0 A				
Excitation Mode		Microstep				

● Encoder Specifications → Page 26

● For the right angle type with an installation plate, an **R** (right angle) indicating the connector configuration is specified where the box □ is located in the product name.

Speed – Torque Characteristics (Reference values)

PKP243

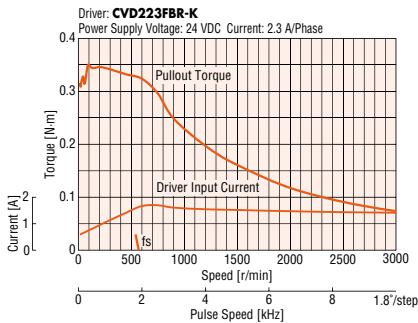

PKP244

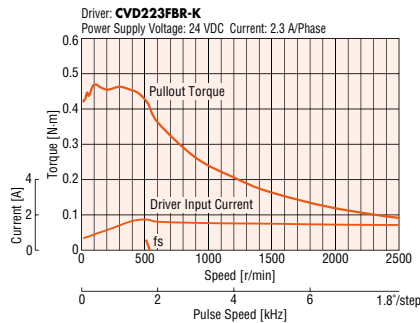

PKP245

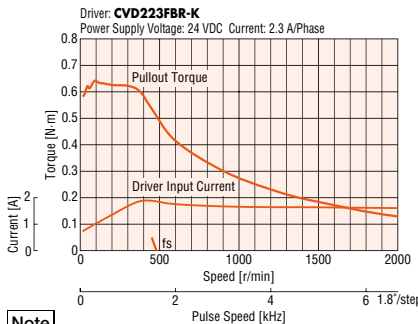

PKP246

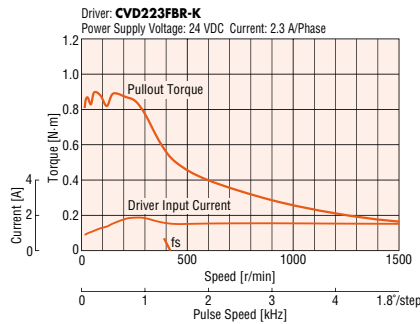

Note

- Data for the speed – torque characteristics is based on Oriental Motor's internal measurement conditions. If the conditions are changed, the characteristics may also change as a result.
- Depending on the driving conditions, a considerable amount of heat may be generated by the motor. Be sure to keep the motor case temperature at 100°C or less. For the type with an encoder, to protect the encoder, be sure to keep the motor case temperature at 85°C max.

Frame Size 56.4 mm

1.8° Stepper Motor and Driver Package: Standard Type/Standard Type with Encoder

Specifications



Motor Product Name	Single Shaft	PKP264D28A2	PKP266D28A2	PKP268D28A2
	Double Shaft	PKP264D28B2	PKP266D28B2	PKP268D28B2
	With Encoder	PKP264D28A2-R2EL PKP264D28A2-R2FL	PKP266D28A2-R2EL PKP266D28A2-R2FL	PKP268D28A2-R2EL PKP268D28A2-R2FL
Driver Product Name		CVD228B□-K	CVD228B□-K	CVD228B□-K
Maximum Holding Torque	N·m	0.74	1.4	2.5
Holding Torque at Motor Standstill	N·m	0.37	0.7	1.3
Rotor Inertia	J: kg·m ²	140×10 ⁻⁷	270×10 ⁻⁷	500×10 ⁻⁷
Rated Current	A / Phase	2.8		
Basic Step Angle		1.8°		
Power Supply Input		24 VDC±10% 3.0 A		
Excitation Mode		Microstep		

● Encoder Specifications → Page 26

● For the right angle type with an installation plate, an **R** (right angle) indicating the connector configuration is specified where the box □ is located in the product name.

Speed – Torque Characteristics (Reference values)

PKP264

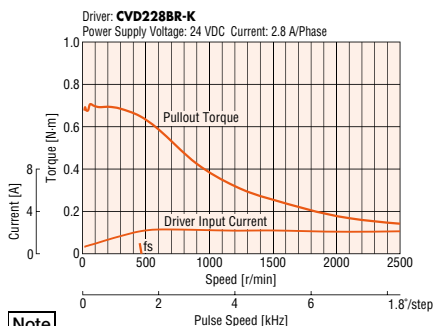

PKP266

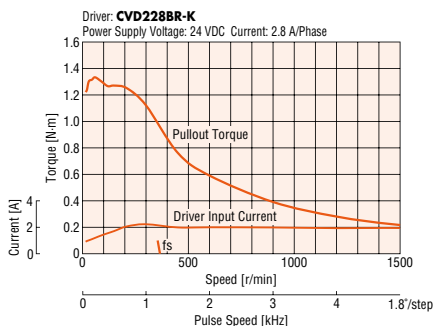

PKP268

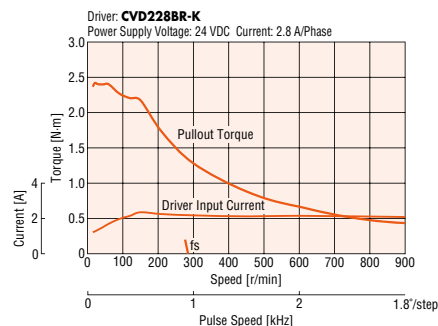

Note

● Data for the speed – torque characteristics is based on Oriental Motor's internal measurement conditions. If the conditions are changed, the characteristics may also change as a result.

● Depending on the driving conditions, a considerable amount of heat may be generated by the motor. Be sure to keep the motor case temperature at 100°C or less. For the type with an encoder, to protect the encoder, be sure to keep the motor case temperature at 85°C max.

Frame Size 85 mm

1.8° Stepper Motor and Driver Package: Standard Type

Specifications



Motor Product Name	Single Shaft	PKP296D45A	PKP299D45A	PKP2913D45A
	Double Shaft	PKP296D45B	PKP299D45B	PKP2913D45B
Driver Product Name		CVD245B <input type="checkbox"/> -K	CVD245B <input type="checkbox"/> -K	CVD245B <input type="checkbox"/> -K
Maximum Holding Torque	N·m	3.3	6.4	9.5
Holding Torque at Motor Standstill	N·m	1.7	3.2	4.8
Rotor Inertia	J: kg·m ²	1100×10 ⁻⁷	2200×10 ⁻⁷	3400×10 ⁻⁷
Rated Current	A / Phase	4.5		
Basic Step Angle	1.8°			
Power Supply Input	24 VDC±10% 3.9 A			
Excitation Mode	Microstep			

● For the right angle type with an installation plate, an **R** (right angle) indicating the connector configuration is specified where the box is located in the product name.

Speed – Torque Characteristics (Reference values)

PKP296

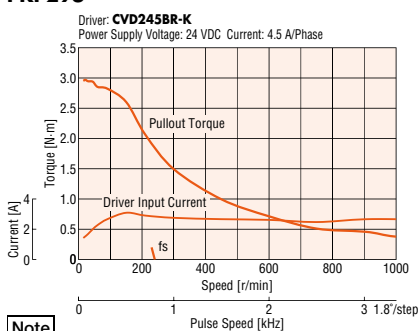

PKP299

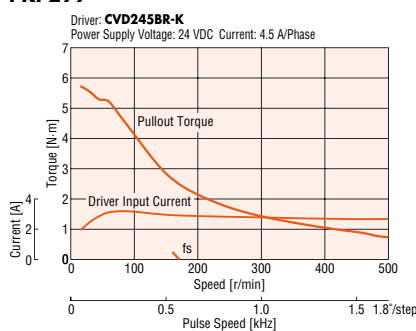

PKP2913

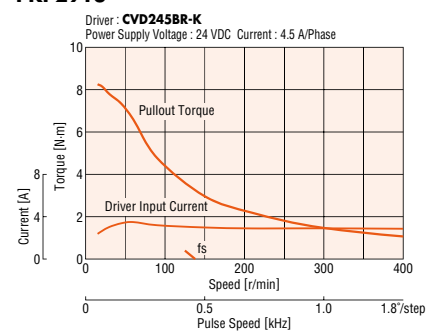

Note

- Data for the speed – torque characteristics is based on Oriental Motor's internal measurement conditions. If the conditions are changed, the characteristics may also change as a result.
- Depending on the driving conditions, a considerable amount of heat may be generated by the motor. Be sure to keep the motor case temperature at 100°C or less.

Frame Size 28 mm

1.8° Stepper Motor and Driver Package: SH Geared Type

Specifications



Motor Product Name	Single Shaft	PKP223D15A-SG7.2	PKP223D15A-SG9	PKP223D15A-SG10	PKP223D15A-SG18	PKP223D15A-SG36
	Double Shaft	PKP223D15B-SG7.2	PKP223D15B-SG9	PKP223D15B-SG10	PKP223D15B-SG18	PKP223D15B-SG36
Driver Product Name		CVD215B-□-K	CVD215B-□-K	CVD215B-□-K	CVD215B-□-K	CVD215B-□-K
Maximum Holding Torque	N·m	0.3	0.3	0.3	0.4	0.4
Rotor Inertia	J: kg·m ²	9×10 ⁻⁷				
Rated Current	A / Phase	1.5				
Basic Step Angle		0.25°	0.2°	0.18°	0.1°	0.05°
Gear Ratio		7.2	9	10	18	36
Permissible Torque	N·m	0.3	0.3	0.3	0.4	0.4
Holding Torque at Motor Standstill	N·m	0.3	0.3	0.3	0.4	0.4
Backlash	arcmin	90 (1.5°)				
Speed Range	r/min	0~416	0~333	0~300	0~166	0~83
Power Supply Input		24 VDC±10% 1.3 A				
Excitation Mode		Microstep				

● For the right angle type with an installation plate, an **R** (right angle) indicating the connector configuration is specified where the box □ is located in the product name.

Speed – Torque Characteristics (Reference values)

PKP223 Gear Ratio 7.2

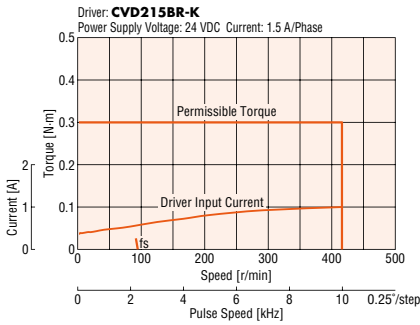

PKP223 Gear Ratio 9

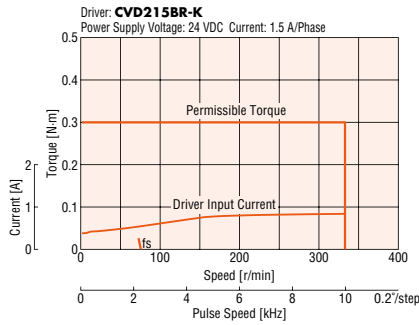

PKP223 Gear Ratio 10

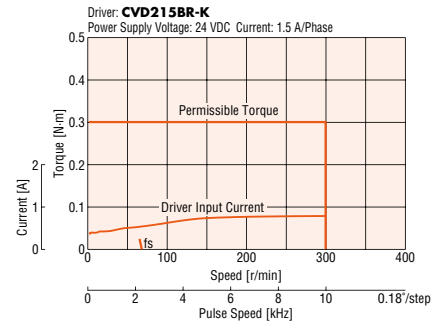

PKP223 Gear Ratio 18

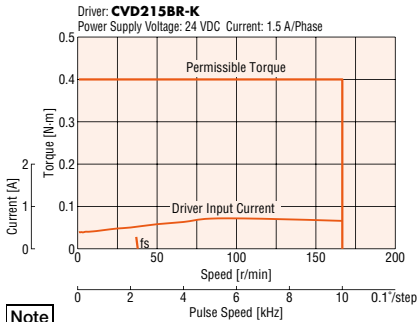

PKP223 Gear Ratio 36

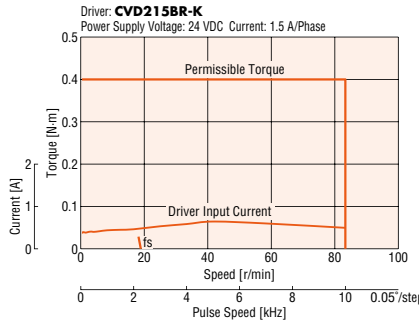

Note

- Data for the speed – torque characteristics is based on Oriental Motor's internal measurement conditions. If the conditions are changed, the characteristics may also change as a result.
- Depending on the driving conditions, a considerable amount of heat may be generated by the motor. Be sure to keep the motor case temperature at 100°C or less.

Frame Size 42 mm

1.8° Stepper Motor and Driver Package: SH Geared Type

Specifications



Motor Product Name	Single Shaft	PKP243D23A2-SG3.6	PKP243D23A2-SG7.2	PKP243D23A2-SG9	PKP243D23A2-SG10	PKP243D23A2-SG18	PKP243D23A2-SG36
	Double Shaft	PKP243D23B2-SG3.6	PKP243D23B2-SG7.2	PKP243D23B2-SG9	PKP243D23B2-SG10	PKP243D23B2-SG18	PKP243D23B2-SG36
Driver Product Name		CVD223FB□-K	CVD223FB□-K	CVD223FB□-K	CVD223FB□-K	CVD223FB□-K	CVD223FB□-K
Maximum Holding Torque	N·m	0.2	0.4	0.5	0.56	0.8	0.8
Rotor Inertia	J: kg·m ²	36×10^{-7}					
Rated Current	A / Phase	2.3					
Basic Step Angle		0.5°	0.25°	0.2°	0.18°	0.1°	0.05°
Gear Ratio		3.6	7.2	9	10	18	36
Permissible Torque	N·m	0.2	0.4	0.5	0.56	0.8	0.8
Holding Torque at Motor Standstill	N·m	0.2	0.4	0.5	0.56	0.8	0.8
Backlash	arcmin	90 (1.5°)					
Speed Range	r/min	0~833	0~416	0~333	0~300	0~166	0~83
Power Supply Input		24 VDC ± 10% 2.0 A					
Excitation Mode		Microstep					

● For the right angle type with an installation plate, an **R** (right angle) indicating the connector configuration is specified where the box □ is located in the product name.

Speed – Torque Characteristics (Reference values)

PKP243 Gear Ratio 3.6

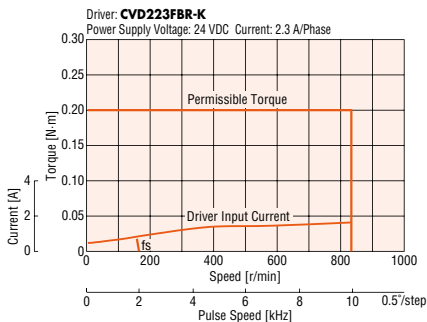

PKP243 Gear Ratio 7.2

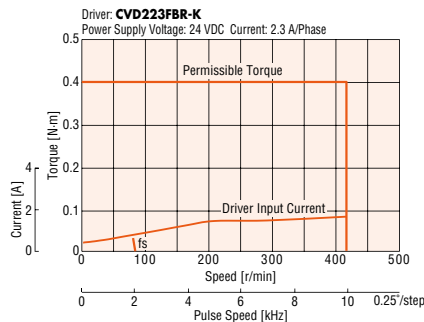

PKP243 Gear Ratio 9

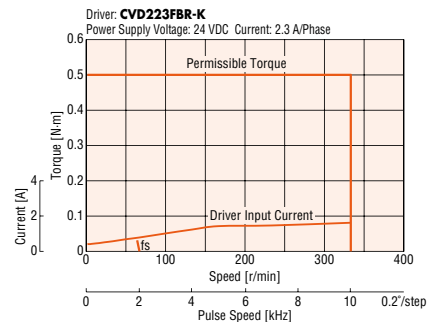

PKP243 Gear Ratio 10

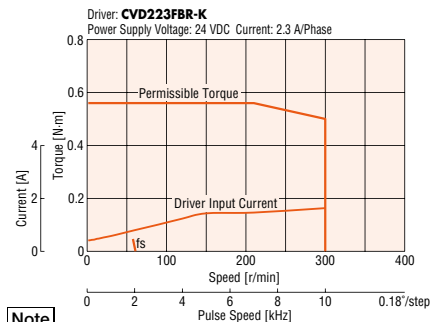

PKP243 Gear Ratio 18

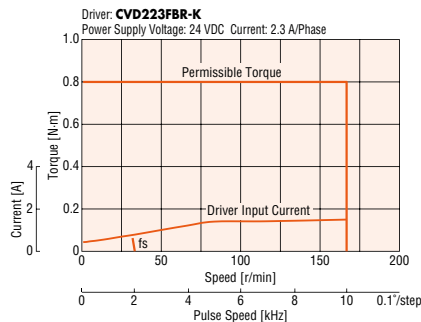

PKP243 Gear Ratio 36

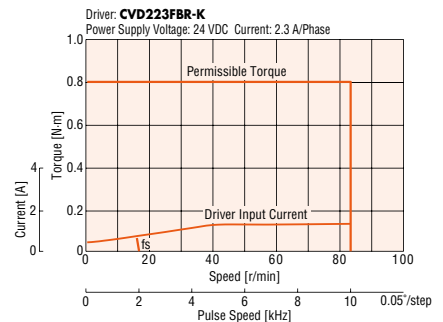

Note

- Data for the speed – torque characteristics is based on Oriental Motor's internal measurement conditions. If the conditions are changed, the characteristics may also change as a result.
- Depending on the driving conditions, a considerable amount of heat may be generated by the motor. Be sure to keep the motor case temperature at 100°C or less.

Frame Size 60 mm

1.8° Stepper Motor and Driver Package: SH Geared Type

Specifications



Motor Product Name	Single Shaft	PKP264D28A2-SG3.6	PKP264D28A2-SG7.2	PKP264D28A2-SG9	PKP264D28A2-SG10	PKP264D28A2-SG18	PKP264D28A2-SG36	
	Double Shaft	PKP264D28B2-SG3.6	PKP264D28B2-SG7.2	PKP264D28B2-SG9	PKP264D28B2-SG10	PKP264D28B2-SG18	PKP264D28B2-SG36	
Driver Product Name		CVD228B□-K	CVD228B□-K	CVD228B□-K	CVD228B□-K	CVD228B□-K	CVD228B□-K	
Maximum Holding Torque	N·m	1	2	2.5	2.7	3	4	
Rotor Inertia	J: kg·m ²	140×10 ⁻⁷						
Rated Current	A / Phase	2.8						
Basic Step Angle		0.5°	0.25°	0.2°	0.18°	0.1°	0.05°	
Gear Ratio		3.6	7.2	9	10	18	36	
Permissible Torque	N·m	1	2	2.5	2.7	3	4	
Holding Torque at Motor Standstill	N·m	1	2	2.5	2.7	3	4	
Backlash	arcmin	70 (1.17°)			45 (0.75°)			
Speed Range	r/min	0~833	0~416	0~333	0~300	0~166	0~83	
Power Supply Input		24 VDC±10% 3.0 A						
Excitation Mode		Microstep						

● For the right angle type with an installation plate, an **R** (right angle) indicating the connector configuration is specified where the box □ is located in the product name.

Speed – Torque Characteristics (Reference values)

PKP264 Gear Ratio 3.6

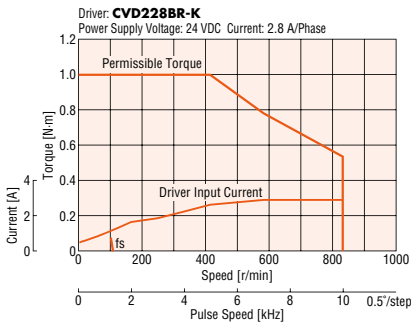

PKP264 Gear Ratio 7.2

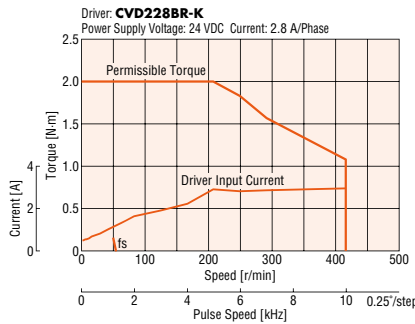

PKP264 Gear Ratio 9

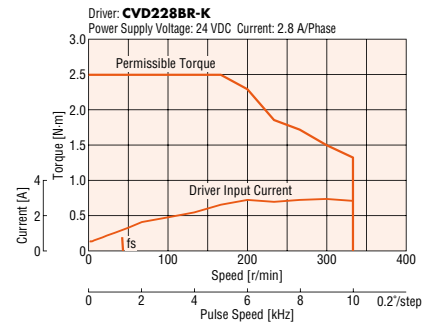

PKP264 Gear Ratio 10

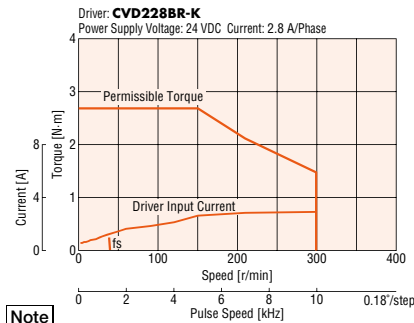

PKP264 Gear Ratio 18

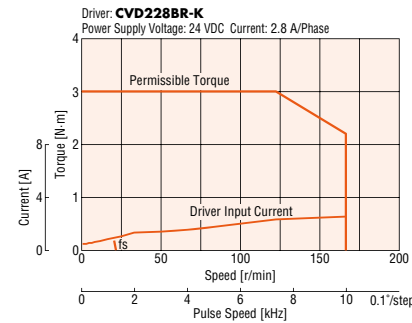

PKP264 Gear Ratio 36

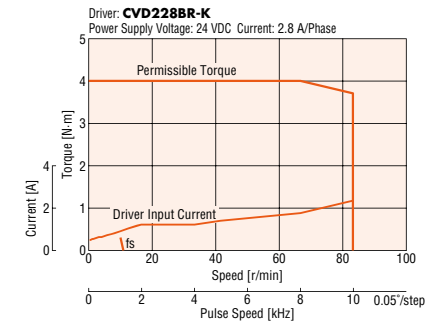

Note

- Data for the speed – torque characteristics is based on Oriental Motor's internal measurement conditions. If the conditions are changed, the characteristics may also change as a result.
- Depending on the driving conditions, a considerable amount of heat may be generated by the motor. Be sure to keep the motor case temperature at 100°C or less.

Frame Size 20 mm, 28 mm

0.72° Stepper Motor and Driver Package: Standard Type/Standard Type with Encoder

Specifications



Motor Product Name	Single Shaft	PK513PA	PKP523N12A	PKP525N12A
	Double Shaft	PK513PB	PKP523N12B	PKP525N12B
	With Encoder	PK513PA-R2GL	—	—
Driver Product Name		CVD503B□-K	CVD512B□-K	CVD512B□-K
Maximum Holding Torque	N·m	0.0231	0.052	0.091
Holding Torque at Motor Standstill	N·m	0.012	0.026	0.045
Rotor Inertia	J: kg·m ²	1.6×10 ⁻⁷ [1.66×10 ⁻⁷]	9×10 ⁻⁷	18×10 ⁻⁷
Rated Current	A / Phase	0.35	1.2	
Basic Step Angle		0.72°		
Power Supply Input		24 VDC±10% 0.6 A	24 VDC±10% 1.7 A	
Excitation Mode		Microstep		

● Encoder Specifications → Page 26

● For the right angle type with an installation plate, an **R** (right angle) indicating the connector configuration is specified where the box □ is located in the product name.

● The brackets [] indicate the specifications for the type with an encoder.

Speed – Torque Characteristics (Reference values)

PK513

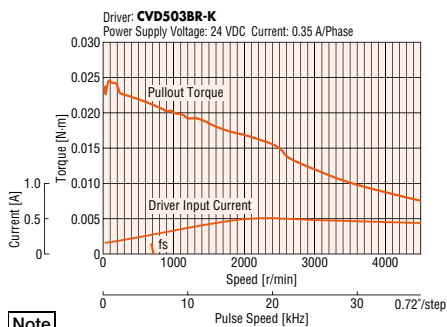

PK523

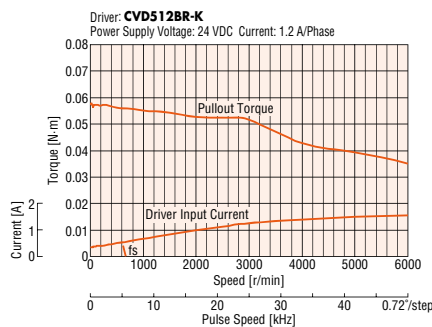

PKP525

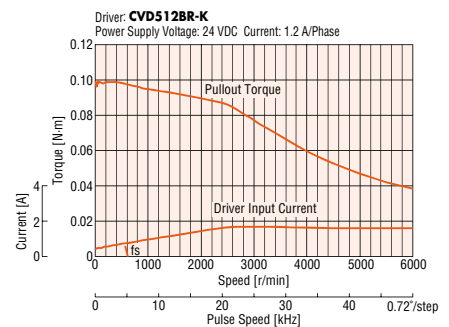

Note

● Data for the speed – torque characteristics is based on Oriental Motor's internal measurement conditions. If the conditions are changed, the characteristics may also change as a result.

● Depending on the driving conditions, a considerable amount of heat may be generated by the motor. Be sure to keep the motor case temperature at 100°C or less. For the type with an encoder, to protect the encoder, be sure to keep the motor case temperature at 85°C max.

Frame Size 42 mm

0.72° Stepper Motor and Driver Package: Standard Type/Standard Type with Encoder

Specifications



Motor Product Name	Single Shaft	PKP543N18A2	PKP544N18A2	PKP545N18A2	PKP546N18A2
	Double Shaft	PKP543N18B2	PKP544N18B2	PKP545N18B2	PKP546N18B2
	With Encoder	PKP543N18A2-R2GL	PKP544N18A2-R2GL	PKP545N18A2-R2GL	PKP546N18A2-R2GL
Driver Product Name		CVD518B□-K	CVD518B□-K	CVD518B□-K	CVD518B□-K
Maximum Holding Torque	N·m	0.22	0.3	0.37	0.5
Holding Torque at Motor Standstill	N·m	0.11	0.15	0.19	0.25
Rotor Inertia	J: kg·m ²	35×10 ⁻⁷	55×10 ⁻⁷	71×10 ⁻⁷	110×10 ⁻⁷
Rated Current	A / Phase	1.8			
Basic Step Angle		0.72°			
Power Supply Input		24 VDC±10% 2.8 A			
Excitation Mode		Microstep			

● Encoder Specifications → Page 26

● For the right angle type with an installation plate, an **R** (right angle) indicating the connector configuration is specified where the box □ is located in the product name.

Speed – Torque Characteristics (Reference values)

PKP543

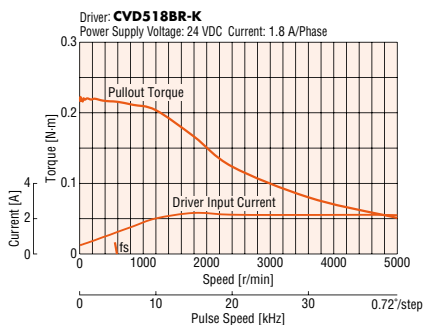

PKP544

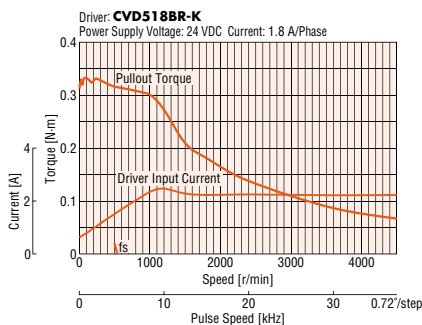

PKP545

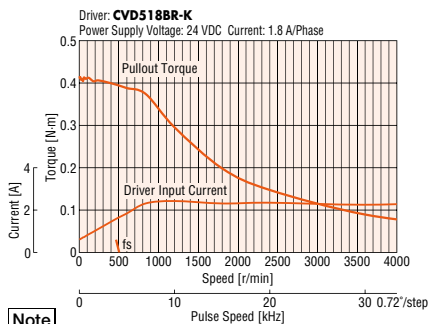

PKP546

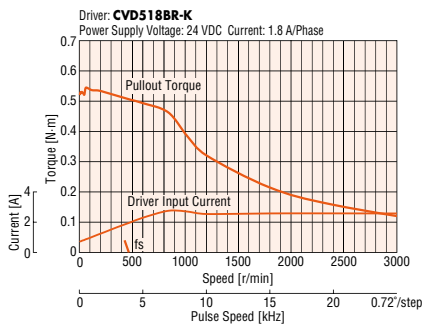

Note

- Data for the speed – torque characteristics is based on Oriental Motor's internal measurement conditions. If the conditions are changed, the characteristics may also change as a result.
- Depending on the driving conditions, a considerable amount of heat may be generated by the motor. Be sure to keep the motor case temperature at 100°C or less. For the type with an encoder, to protect the encoder, be sure to keep the motor case temperature at 85°C max.

Frame Size 42 mm

0.36° Stepper Motor and Driver Package: High-Resolution Type

Specifications



Motor Product Name	Single Shaft	PKP544MN18A	PKP546MN18A
	Double Shaft	PKP544MN18B	PKP546MN18B
Driver Product Name		CVD518B -K	CVD518B -K
Maximum Holding Torque	N·m	0.26	0.44
Holding Torque at Motor Standstill	N·m	0.13	0.22
Rotor Inertia	J: kg·m ²	60×10 ⁻⁷	121×10 ⁻⁷
Rated Current	A / Phase	1.8	
Basic Step Angle		0.36°	
Power Supply Input		24 VDC ± 10% 2.8 A	
Excitation Mode		Microstep	

● For the right angle type with an installation plate, an **R** (right angle) indicating the connector configuration is specified where the box is located in the product name.

Speed – Torque Characteristics (Reference values)

PKP544M

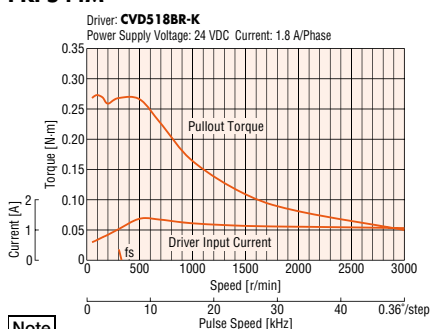

PKP546M

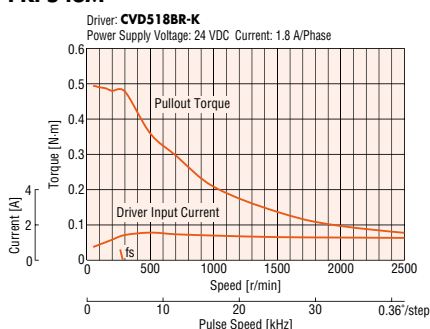

Note

- Data for the speed – torque characteristics is based on Oriental Motor's internal measurement conditions. If the conditions are changed, the characteristics may also change as a result.
- Depending on the driving conditions, a considerable amount of heat may be generated by the motor. Be sure to keep the motor case temperature at 100°C or less.

Frame Size 56.4 mm

0.72° Stepper Motor and Driver Package: Standard Type/Standard Type with Encoder

Specifications



Motor Product Name	Single Shaft	PKP564N28A2	PKP566N28A2	PKP568N28A2
	Double Shaft	PKP564N28B2	PKP566N28B2	PKP568N28B2
	With Encoder	PKP564N28A2-R2GL	PKP566N28A2-R2GL	PKP568N28A2-R2GL
Driver Product Name		CVD528B□-K	CVD528B□-K	CVD528B□-K
Maximum Holding Torque	N·m	0.44	0.81	1.5
Holding Torque at Motor Standstill	N·m	0.22	0.41	0.75
Rotor Inertia	J: kg·m ²	140×10 ⁻⁷	270×10 ⁻⁷	500×10 ⁻⁷
Rated Current	A / Phase	2.8		
Basic Step Angle		0.72°		
Power Supply Input		24 VDC±10% 4.8 A		
Excitation Mode		Microstep		

● Encoder Specifications → Page 26

● For the right angle type with an installation plate, an **R** (right angle) indicating the connector configuration is specified where the box □ is located in the product name.

Speed – Torque Characteristics (Reference values)

PKP564

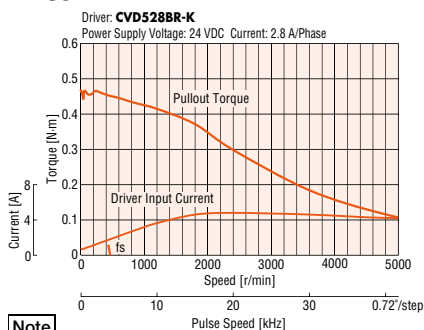

PKP566

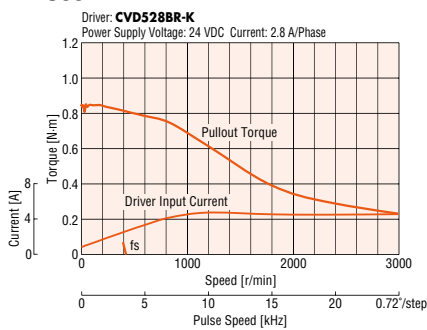

PKP568

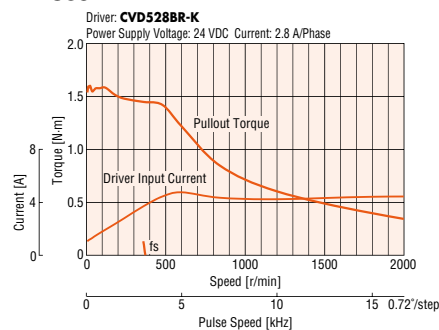

Note

- Data for the speed – torque characteristics is based on Oriental Motor's internal measurement conditions. If the conditions are changed, the characteristics may also change as a result.
- Depending on the driving conditions, a considerable amount of heat may be generated by the motor. Be sure to keep the motor case temperature at 100°C or less. For the type with an encoder, to protect the encoder, be sure to keep the motor case temperature at 85°C max.

Frame Size 60 mm

0.72° Stepper Motor and Driver Package: Standard Type/Standard Type with Encoder

Specifications



Motor Product Name	Single Shaft	PKP564FN24A2	PKP564FN38A2	PKP566FN24A2	PKP566FN38A2	PKP569FN24A2	PKP569FN38A2
	Double Shaft	PKP564FN24B2	PKP564FN38B2	PKP566FN24B2	PKP566FN38B2	PKP569FN24B2	PKP569FN38B2
	With Encoder	PKP564FN24A2-R2GL	PKP564FN38A2-R2GL	PKP566FN24A2-R2GL	PKP566FN38A2-R2GL	PKP569FN24A2-R2GL	PKP569FN38A2-R2GL
Driver Product Name		CVD524B <input type="checkbox"/> -K	CVD538B <input type="checkbox"/> -K	CVD524B <input type="checkbox"/> -K	CVD538B <input type="checkbox"/> -K	CVD524B <input type="checkbox"/> -K	CVD538B <input type="checkbox"/> -K
Maximum Holding Torque	N·m	0.66		1.15		2.1	
Holding Torque at Motor Standstill	N·m	0.33		0.58		1.1	
Rotor Inertia	J: kg·m ²	160×10 ⁻⁷		290×10 ⁻⁷		540×10 ⁻⁷	
Rated Current	A / Phase	2.4	3.8	2.4	3.8	2.4	3.8
Basic Step Angle		0.72°					
Power Supply Input		24 VDC±10% 3.0 A	24 VDC±10% 4.8 A	24 VDC±10% 3.0 A	24 VDC±10% 4.8 A	24 VDC±10% 3.0 A	24 VDC±10% 4.8 A
Excitation Mode		Microstep					

● Encoder Specifications → Page 26

● For the right angle type with an installation plate, an **R** (right angle) indicating the connector configuration is specified where the box is located in the product name.

Speed – Torque Characteristics (Reference values)

PKP564FN24

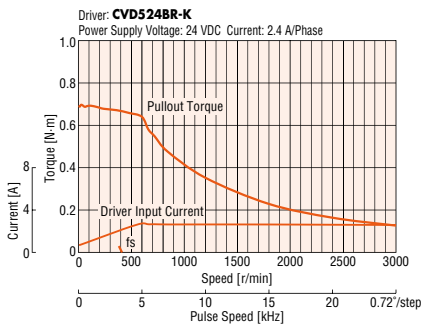

PKP566FN24

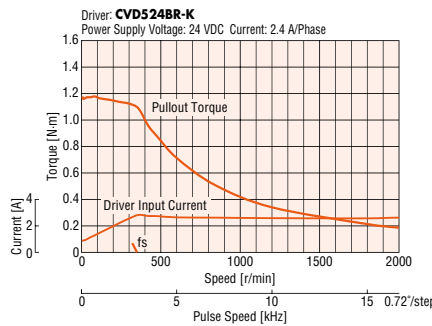

PKP569FN24

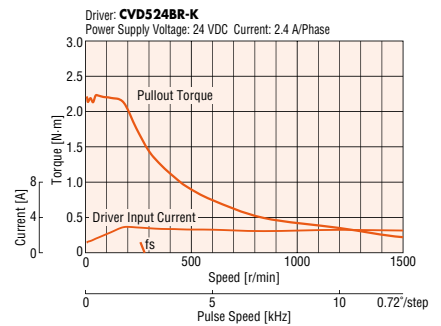

PKP564FN38

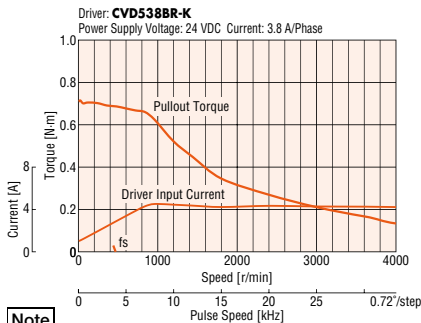

PKP566FN38

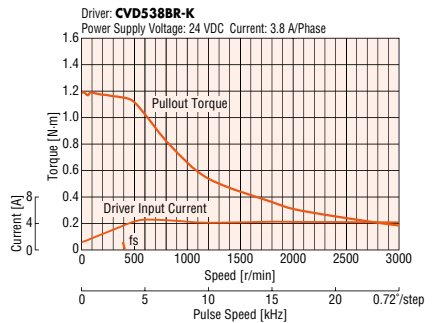

PKP569FN38

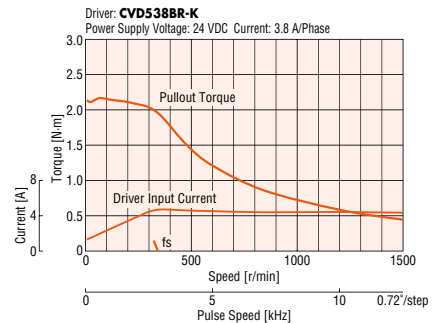

Note

- Data for the speed – torque characteristics is based on Oriental Motor's internal measurement conditions. If the conditions are changed, the characteristics may also change as a result.
- Depending on the driving conditions, a considerable amount of heat may be generated by the motor. Be sure to keep the motor case temperature at 100°C or less. For the type with an encoder, to protect the encoder, be sure to keep the motor case temperature at 85°C max.

Frame Size 60 mm

0.36° Stepper Motor and Driver Package: High-Resolution Type

Specifications



Motor Product Name	Single Shaft	PKP564FMN24A	PKP566FMN24A	PKP569FMN24A
	Double Shaft	PKP564FMN24B	PKP566FMN24B	PKP569FMN24B
Driver Product Name		CVD524B □ -K	CVD524B □ -K	CVD524B □ -K
Maximum Holding Torque	N·m	0.78	1.25	2.3
Holding Torque at Motor Standstill	N·m	0.39	0.63	1.15
Rotor Inertia	J: kg·m ²	310×10 ⁻⁷	490×10 ⁻⁷	970×10 ⁻⁷
Rated Current	A / Phase	2.4		
Basic Step Angle	0.36°			
Power Supply Input	24 VDC ±10% 2.7 A			
Excitation Mode	Microstep			

● For the right angle type with an installation plate, an **R** (right angle) indicating the connector configuration is specified where the box □ is located in the product name.

Speed – Torque Characteristics (Reference values)

PKP564FMN24

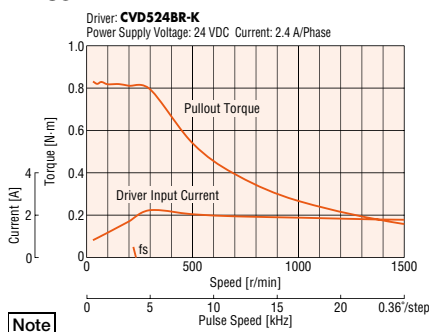

PKP566FMN24

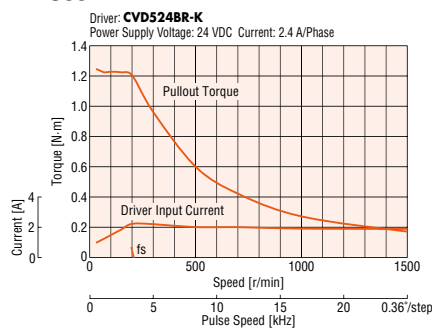

PKP569FMN24

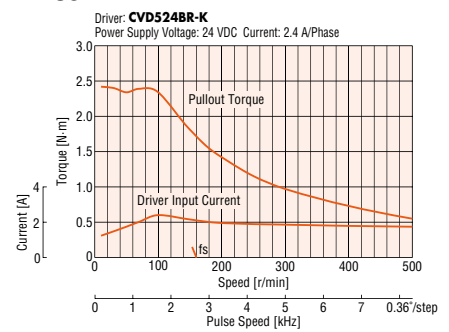

Note

- Data for the speed – torque characteristics is based on Oriental Motor's internal measurement conditions. If the conditions are changed, the characteristics may also change as a result.
- Depending on the driving conditions, a considerable amount of heat may be generated by the motor. Be sure to keep the motor case temperature at 100°C or less.

Frame Size 85 mm

0.72° Stepper Motor and Driver Package: Standard Type

Specifications



Motor Product Name	Single Shaft	PK596HNAW	PK599HNAW	PK5913HNAW
	Double Shaft	PK596HNBW	PK599HNBW	PK5913HNBW
Driver Product Name		CVD528B -K	CVD528B -K	CVD528B -K
Maximum Holding Torque	N·m	2.1	4.1	6.3
Holding Torque at Motor Standstill	N·m	1.1	2.1	3.2
Rotor Inertia	J: kg·m ²	1400×10 ⁻⁷	2700×10 ⁻⁷	4000×10 ⁻⁷
Rated Current	A / Phase	2.8		
Basic Step Angle		0.72°		
Power Supply Input		24 VDC±10% 4.8 A		
Excitation Mode		Microstep		

● For the right angle type with an installation plate, an **R** (right angle) indicating the connector configuration is specified where the box is located in the product name.

Speed – Torque Characteristics (Reference values)

PK596

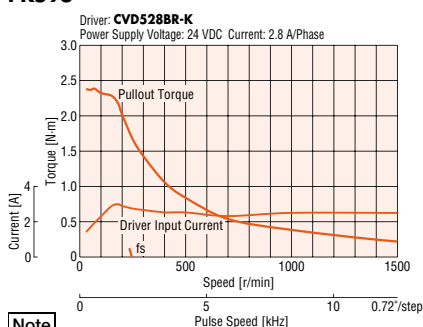

PK599

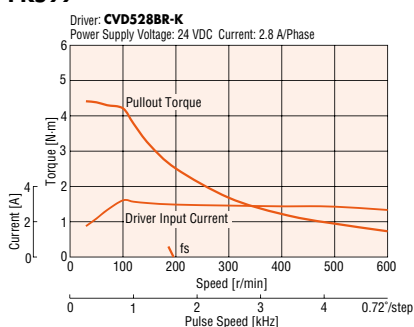

PK5913

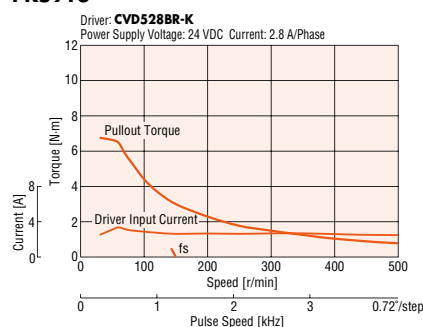

Note

- Data for the speed – torque characteristics is based on Oriental Motor's internal measurement conditions. If the conditions are changed, the characteristics may also change as a result.
- Depending on the driving conditions, a considerable amount of heat may be generated by the motor. Be sure to keep the motor case temperature at 100°C or less.

Driver Specifications

Maximum Input Pulse Frequency	Line driver output by programmable controller: 1 MHz (When the pulse duty is 50%) Open-collector output by programmable controller: 250 kHz (When the pulse duty is 50%) Negative Logic Pulse Input
Input Signal	Photocoupler Input, input current 5~15 mA, input voltage 3~5.25 VDC [PLS (CW), DIR. (CCW)] Photocoupler Input, input current 5~15 mA, input voltage 4.5~5.25 VDC (AWO, CS)
Output Signal	Photocoupler and open-collector output, External operating conditions: 30 VDC 10 mA max. (ALM, TIM)

General Specifications

	Motor	Driver
Thermal Class	130 (B)	—
Insulation Resistance	The measured value is 100 MΩ min. when a 500 VDC megger is applied between the windings and the case under normal ambient temperature and humidity.	—
Dielectric Voltage	No abnormalities are observed, even when applying voltage between the windings and the case for 1 minute under normal ambient temperature and humidity with the following conditions. <ul style="list-style-type: none"> PKP21□, PKP22□, PKP23□, PKP24□, PK513, PKP52□, PKP54□: 0.5 kVAC 50/60 Hz PKP26□, PKP56□: 1.0 kVAC 50/60 Hz PKP29□, PKP56□FMN, PK59□: 1.5 kVAC 50/60 Hz 	—
Operating Environment (In operation)	Ambient Temperature	−10~+50°C (Non-freezing)
	Ambient Humidity	85% or less (Non-condensing)
	Atmosphere	No corrosive gases or dust. The product should not be exposed to water, oil or other liquids.
Temperature Rise	Winding temperature rise 80°C max. (Based on Oriental Motor's internal measurement conditions)	—
Stop Position Accuracy*1	Standard type: ±3 arc minutes (±0.05°) [PKP21□ is ±5 arc minutes (±0.083°), PK513 is ±10 arc minutes (±0.17°)] High-resolution type: ±2 arc minutes (±0.034°)	—
Shaft Runout	0.05 T.I.R. (mm)*4	—
Radial Play*2	0.025 mm max. (5 N load)	—
Axial Play*3	0.075 mm max. (10 N load) [PKP21□ and PK513 are 1 N load, PKP22□ and PKP52□ are 2.5 N load]	—
Concentricity of Installation Pilot to the Shaft	0.075 T.I.R. (mm)*4	—
Perpendicularity of Installation Surface to the Shaft	0.075 T.I.R. (mm)*4	—

*1 This value is for a full step under no load. (The value changes with the size of the load.)

*2 Radial Play: Displacement in shaft position in the radial direction when a 5 N load is applied perpendicular to the tip of the motor shaft.

*3 Axial Play: Displacement in shaft position in the axial direction when a 10 N (PKP21□ and PK513 are 1 N, PKP22□ and PKP52□ are 2.5 N) load is applied to the motor shaft in the axial direction.

*4 T. I. R. (Total Indicator Reading): The total dial gauge reading when the measurement section is rotated once around the reference axis center.

Note

- Do not measure insulation resistance or perform a dielectric strength test while the motor and driver are connected.
Also, do not conduct these tests on the motor encoder section.

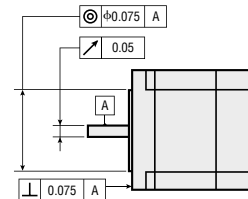

Encoder Specifications

Encoder Product Name	R2EL	R2FL	R2GL
Resolution	200P/R	400P/R	500P/R
Output Circuit Type	Line Driver		
Output Mode	Incremental		
Output Signal	A phase, B phase, Z phase (3 ch)		
Power Supply Voltage	5 VDC ±10%		
Current	30 mA max.		

- A voltage output type of encoder output circuit is also available.
For details, please contact your nearest Oriental Motor sales office.

Permissible Radial Load and Permissible Axial Load

→ Page 27

Rotation direction

This indicates the rotation direction as viewed from the output shaft side of the motor (factory setting).

The rotation direction of the output gear shaft relative to the standard type motor output shaft varies depending on the gear type and gear ratio. Please check the following table.

Type	Gear Ratio	Rotation direction Relative to Motor Output Shaft
SH Geared Frame Size 28mm	7.2, 36	Same direction
	9, 10, 18	Opposite direction
SH Geared Frame Size 42mm, 60mm	3.6, 7.2, 9, 10	Same direction
	18, 36	Opposite direction

Standard Type Motor

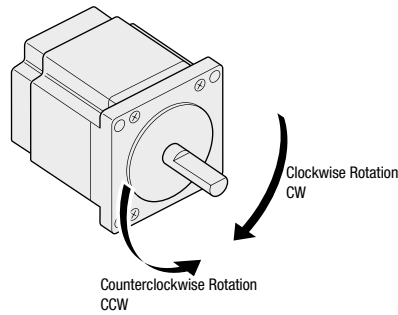

CVK Series 1.8°/0.9° Stepper Motors, 0.72°/0.36° Stepper Motors

Unit: N

Type	Motor Frame Size	Product Name	Gear Ratio	Permissible Radial Load					Permissible Axial Load	
				Distance from Shaft End [mm]						
				0	5	10	15	20		
High-Resolution Type	42 mm	PKP243, PKP244 PKP544, PKP546	-	20	25	34	52	—	10	
	56.4 mm	PKP264, PKP266, PKP268		61	73	90	110	160	20	
	60 mm	PKP564, PKP566, PKP569		90	100	130	180	270	20	
Standard Type	20 mm	PKP213, PKP214 PK513	-	12	15	—	—	—	3	
	28 mm	PKP223, PKP225 PKP523, PKP525		25	34	52	—	—	5	
	35 mm	PKP233, PKP235		20	25	34	52	—	10	
	42 mm	PKP243, PKP244, PKP245 PKP246, PKP544, PKP546		20	25	34	52	—	10	
		PKP243□2, PKP244□2, PKP245□2, PKP246□2, PKP543□2, PKP544□2, PKP545□2, PKP546□2		35	44	58	85	—	15	
	56.4 mm	PKP264, PKP266, PKP268		61	73	90	110	160	20	
		PKP264□2, PKP266□2, PKP268□2		90	100	130	180	270	30	
	60 mm	PKP564, PKP566, PKP569		90	100	130	180	270	30	
		PKP262		20	25	34	—	—	5	
	85 mm	PKP296, PKP299, PKP2913 PK596, PK599, PK5913		260	290	340	390	480	60	
SH Geared Type	28 mm	PKP223	7.2, 9, 10, 18, 36	15	17	20	23	—	10	
	42 mm	PKP243	3.6, 7.2, 9, 10, 18, 36	10	15	20	30	—	15	
	60 mm	PKP264	3.6, 7.2, 9, 10	30	40	50	60	70	30	
18, 36			80	100	120	140	160			

● The product names are listed such that the product names are distinguishable.

Radial Load and Axial Load

Distance from Shaft End [mm]

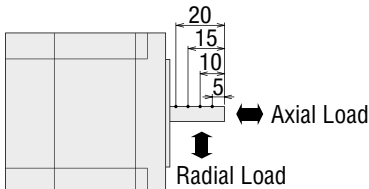

Dimensions (Unit = mm)

● Motor

◇ 1.8° Stepper Motor

● Standard Type

Frame Size 20 mm

Product Name	L1	L2	Mass kg
PKP213D05A	30	-	0.05
PKP213D05B		38	
PKP214D06A	40	-	0.07
PKP214D06B		48	

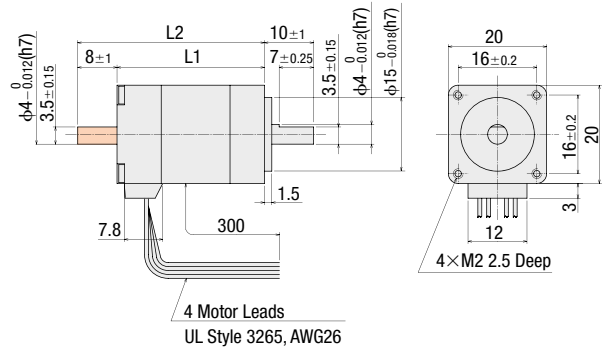

- The back shaft side of the double shaft model is entirely shaft flat.

● Standard Type

Frame Size 28 mm

Product Name	L1	L2	Mass kg
PKP223D15A2	32	-	0.11
PKP223D15B2		42	
PKP225D15A2	51.5	-	0.2
PKP225D15B2		61.5	

- Connection Cable (Sold separately)
Product Name: **LC2B06A**

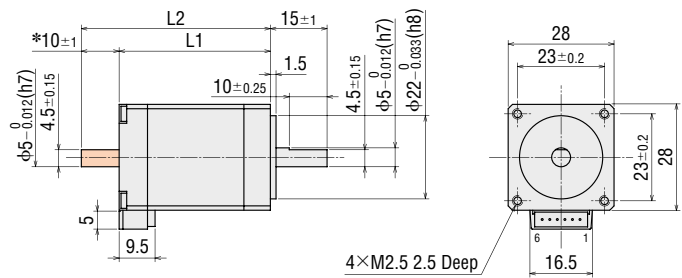

- * The length of the shaft flat on the double shaft model is 10 ± 0.25 .

● Standard Type

Frame Size 35 mm

Product Name	L1	L2	Mass kg
PKP233D23A	37	-	0.18
PKP233D23B		52	
PKP235D23A	52	-	0.285
PKP235D23B		67	

- Connection Cable (Sold separately)
Product Name: **LC2B06B**

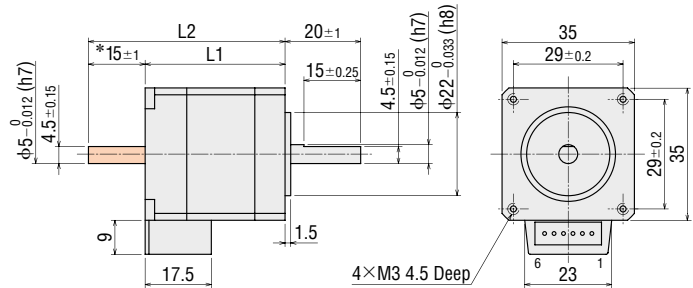

- * The length of the shaft flat on the double shaft model is 15 ± 0.25 .

● Standard Type

Frame Size 42 mm

Product Name	L1	L2	Mass kg
PKP243D23A2	33	-	0.23
PKP243D23B2		48	
PKP244D23A2	39	-	0.3
PKP244D23B2		54	
PKP245D23A2	47	-	0.37
PKP245D23B2		62	
PKP246D23A2	59	-	0.5
PKP246D23B2		74	

- Connection Cable (Sold separately)
Product Name: **LC2B06E**

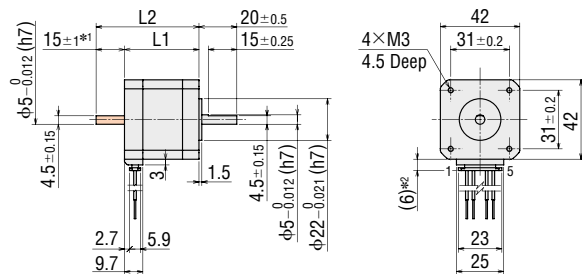

- *1 The length of the shaft flat on the double shaft model is 15 ± 0.25 .
- *2 With connection cable

- These dimensions are for double shaft motors. For single shaft motors, ignore the shaded areas.

● Standard Type

Frame Size 56.4 mm

Product Name	L1	L2	Mass kg
PKP264D28A2	39	—	0.45
PKP264D28B2		62	
PKP266D28A2	54	—	0.7
PKP266D28B2		77	
PKP268D28A2	76	—	1.1
PKP268D28B2		99	

● Connection Cable (Sold separately)

Product Name: **LC2B06E**

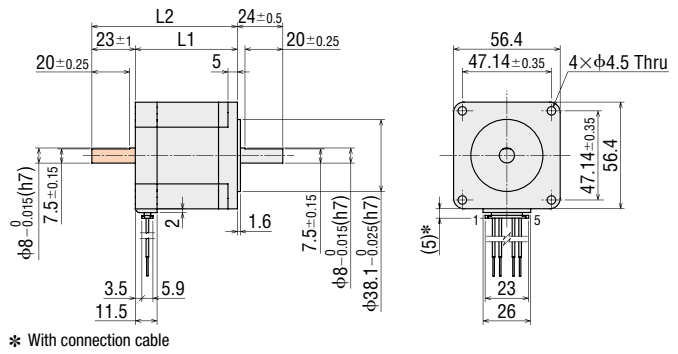

● Standard Type

Frame Size 85 mm

Product Name	L1	L2	Mass kg
PKP296D45A	66	—	1.8
PKP296D45B		100	
PKP299D45A	96	—	2.9
PKP299D45B		130	
PKP2913D45A	126	—	4
PKP2913D45B		160	

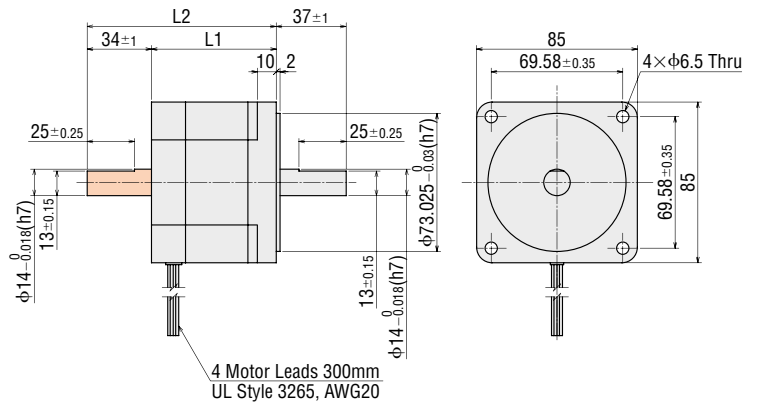

● Standard Type with Encoder

Frame Size 20 mm

Product Name	L	Mass kg
PKP213D05A-R2EL	46.5	0.06
PKP214D06A-R2EL	56.5	0.08

● Connection Cable (Sold separately)

Product Name: **LCE08A-006** (For encoder)

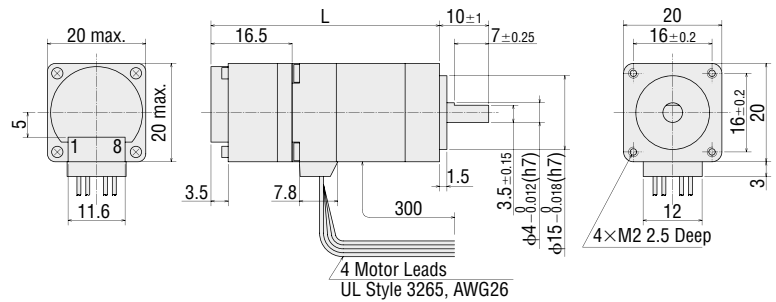

● These dimensions are for double shaft motors. For single shaft motors, ignore the shaded areas.

● Standard Type with Encoder

Frame Size 28 mm

Product Name	L	Mass kg
PKP223D15A2-R2EL	47.5	0.12
PKP225D15A2-R2EL	67	0.21

● Connection Cable (Sold separately)
Product Name: **LC2B06A** (For motor)

LCE08A-006 (For encoder)

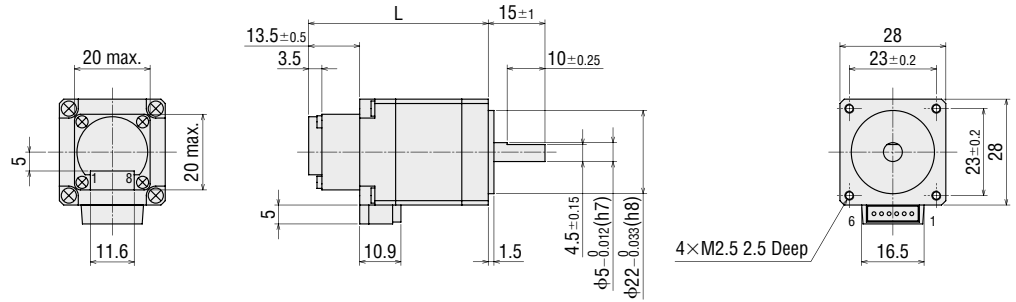

● Standard Type with Encoder

Frame Size 42 mm

Product Name	L	Mass kg
PKP243D23A2-R2EL	46.5	0.24
PKP244D23A2-R2EL	52.5	0.31
PKP245D23A2-R2EL	60.5	0.38
PKP246D23A2-R2EL	72.5	0.51

● Connection Cable (Sold separately)
Product Name: **LC2B06E** (For motor)

LCE08A-006 (For encoder)

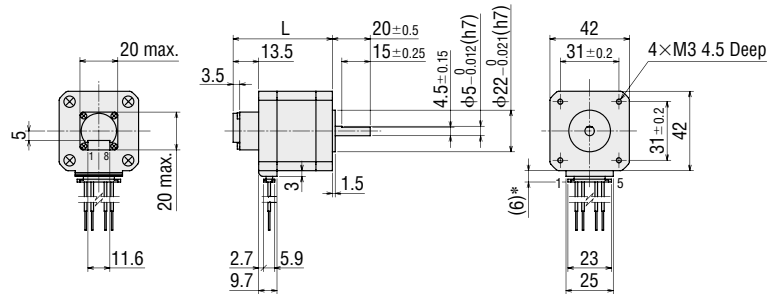

* With connection cable

● Standard Type with Encoder

Frame Size 56.4 mm

Product Name	L	Mass kg
PKP264D28A2-R2EL	55.5	0.45
PKP266D28A2-R2EL	70.5	0.7
PKP268D28A2-R2EL	92.5	1.1

● Connection Cable (Sold separately)
Product Name: **LC2B06E** (For motor)

LCE08A-006 (For encoder)

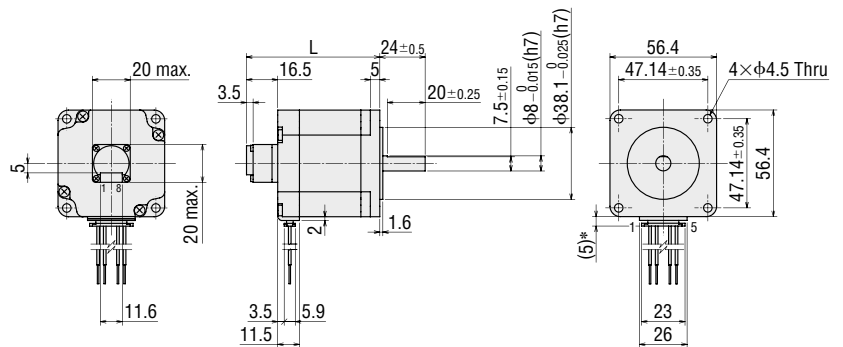

* With connection cable

●SH Geared Type

Frame Size 28 mm

Product Name	Gear Ratio	Mass kg
PKP223D15A-SG□	7.2, 9,	0.16
PKP223D15B-SG□	10, 18, 36	

- A number indicating the gear ratio is specified where the box □ is located in the product name.
- Connection Cable (Sold separately)

Product Name: **LC2B06A**

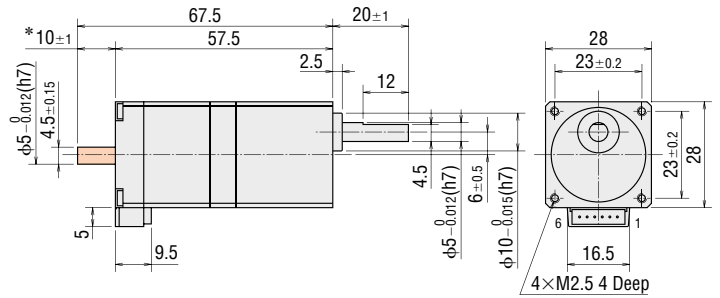

* The length of the shaft flat on the double shaft model is 10±0.25.

●SH Geared Type

Frame Size 42 mm

Product Name	Gear Ratio	Mass kg
PKP243D23A2-SG□	3.6, 7.2, 9,	0.33
PKP243D23B2-SG□	10, 18, 36	

- A number indicating the gear ratio is specified where the box □ is located in the product name.
- Connection Cable (Sold separately)

Product Name: **LC2B06E**

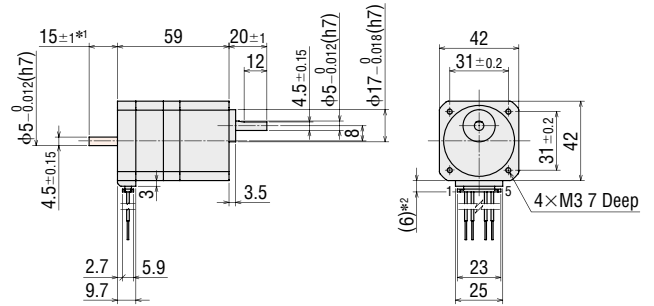

*1 The length of the shaft flat on the double shaft model is 15±0.25.

*2 With connection cable

●SH Geared Type

Frame Size 60 mm

Product Name	Gear Ratio	Mass kg
PKP264D28A2-SG□	3.6, 7.2, 9,	0.76
PKP264D28B2-SG□	10, 18, 36	

- A number indicating the gear ratio is specified where the box □ is located in the product name.
- Connection Cable (Sold separately)

Product Name: **LC2B06E**

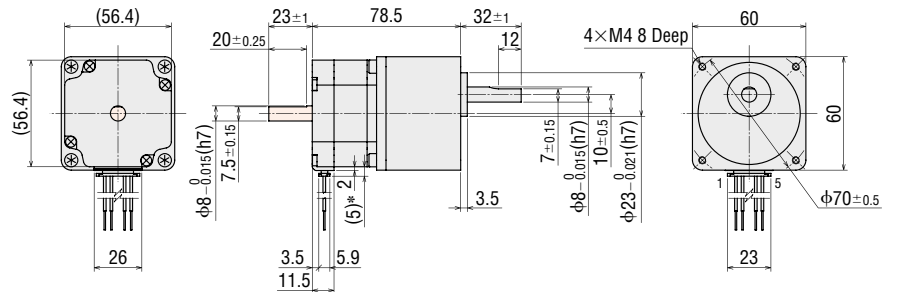

* With connection cable

● These dimensions are for double shaft motors. For single shaft motors, ignore the shaded areas.

◇ 0.72°/0.36° Stepper Motor

● Standard Type

Frame Size 20 mm

Product Name	Mass kg
PK513PA	0.05
PK513PB	

- Connection Cable (Sold separately)
Product Name: **LC5N06A**

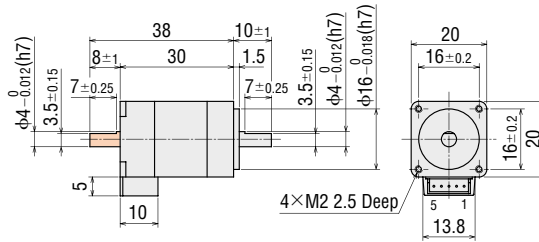

● Standard Type

Frame Size 28 mm

Product Name	L1	L2	Mass kg
PKP523N12A	32	-	0.11
PKP523N12B		42	
PKP525N12A	51.5	-	0.2
PKP525N12B		61.5	

- Connection Cable (Sold separately)
Product Name: **LC5N06A**

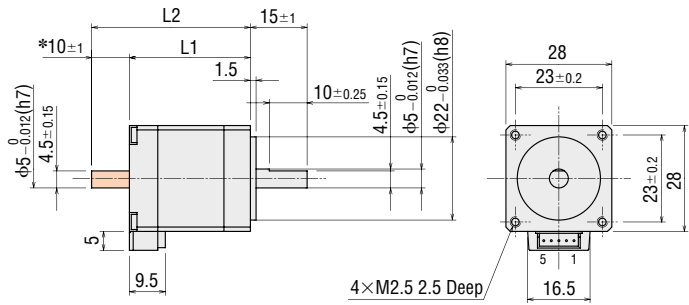

* The length of the shaft flat on the double shaft model is 10 ± 0.25.

● Standard Type

Frame Size 42 mm

Product Name	L1	L2	Mass kg
PKP543N18A2	33	-	0.23
PKP543N18B2		48	
PKP544N18A2	39	-	0.29
PKP544N18B2		54	
PKP545N18A2	47	-	0.37
PKP545N18B2		62	
PKP546N18A2	59	-	0.49
PKP546N18B2		74	

- Connection Cable (Sold separately)
Product Name: **LC5N06E**

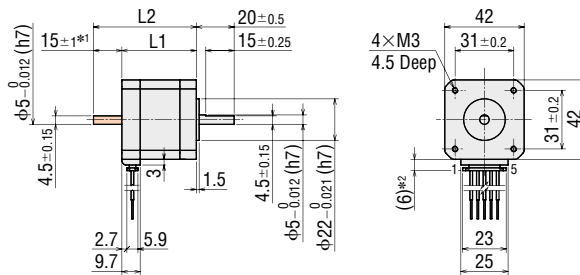

*1 The length of the shaft flat on the double shaft model is 15 ± 0.25.

*2 With connection cable

● These dimensions are for double shaft motors. For single shaft motors, ignore the shaded areas.

●High-Resolution Type

Frame Size 42 mm

Product Name	L1	L2	Mass kg
PKP544MN18A	39	-	0.3
PKP544MN18B		54	
PKP546MN18A	59	-	0.5
PKP546MN18B		74	

● Connection Cable (Sold separately)
Product Name: **LC5N06B**

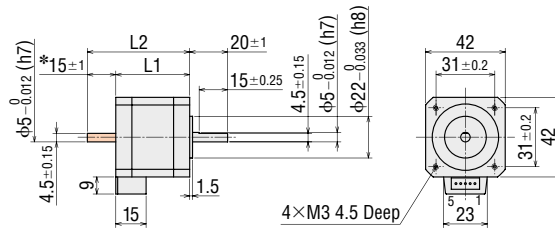

* The length of the shaft flat on the double shaft model is 15 ± 0.25 .

●Standard Type

Frame Size 56.4 mm

Product Name	L1	L2	Mass kg
PKP564N28A2	39	-	0.43
PKP564N28B2		62	
PKP566N28A2	54	-	0.67
PKP566N28B2		77	
PKP568N28A2	76	-	1
PKP568N28B2		99	

● Connection Cable (Sold separately)
Product Name: **LC5N06E**

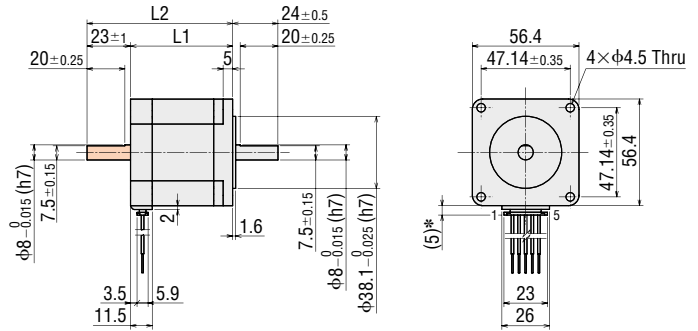

* With connection cable

●Standard Type

Frame Size 60 mm

Product Name	L1	L2	Mass kg
PKP564FN24A2	44	-	0.56
PKP564FN24B2		65	
PKP564FN38A2		-	
PKP564FN38B2		65	
PKP566FN24A2	56	-	0.79
PKP566FN24B2		77	
PKP566FN38A2		-	
PKP566FN38B2	77		
PKP569FN24A2	84.5	-	1.3
PKP569FN24B2		105.5	
PKP569FN38A2		-	
PKP569FN38B2		105.5	

● Connection Cable (Sold separately)
Product Name: **LC5N06E**

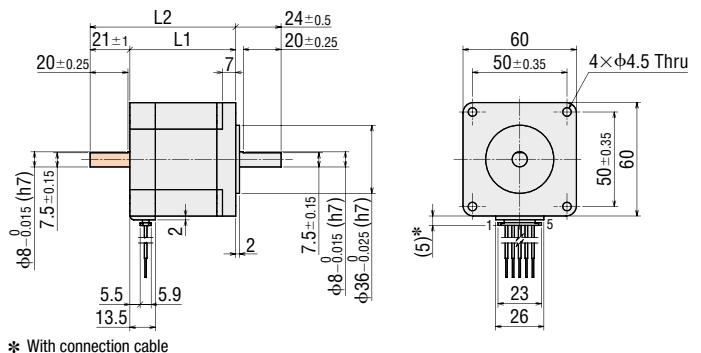

* With connection cable

● These dimensions are for double shaft motors. For single shaft motors, ignore the shaded areas.

●High-Resolution Type

Frame Size 60 mm

Product Name	L1	L2	L3	φD	Mass kg
PKP564FMN24A	46.5	-	7.5±0.15	8 ⁰ _{-0.015}	0.65
PKP564FMN24B		69.5			
PKP566FMN24A	56	-	7.5±0.15	8 ⁰ _{-0.015}	0.87
PKP566FMN24B		79			
PKP569FMN24A	87	-	9.5±0.15	10 ⁰ _{-0.015}	1.5
PKP569FMN24B		110			

● Connection Cable (Sold separately)

Product Name: **LC5N06C**

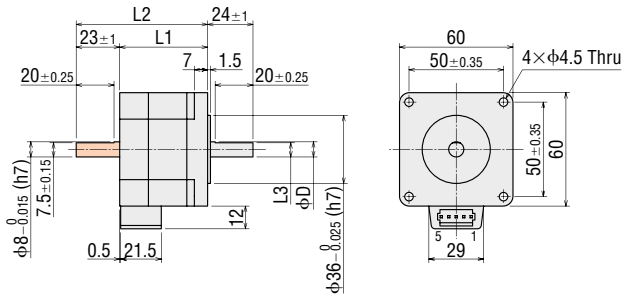

●Standard Type

Frame Size 85 mm

Product Name	L1	L2	Mass kg
PK596HNAW	66	-	1.7
PK596HNBW		100	
PK599HNAW	96	-	2.8
PK599HNBW		130	
PK5913HNAW	126	-	3.8
PK5913HNBW		160	

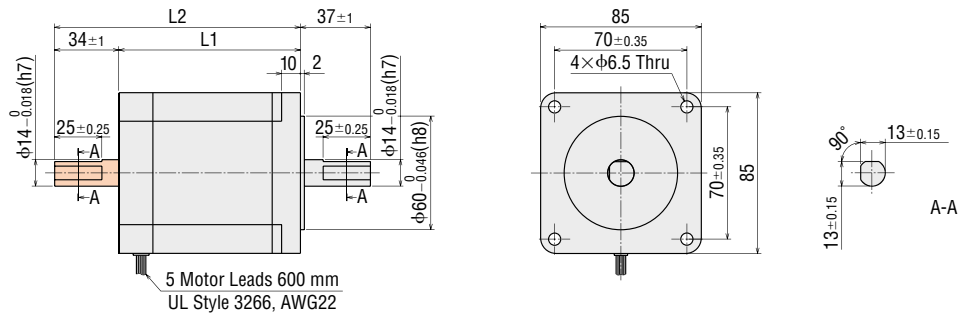

●Standard Type with Encoder

Frame Size 20 mm

Product Name	Mass kg
PK513PA-R2GL	0.06

● Connection Cable (Sold separately)

Product Name: **LC5N06A** (For motor)

● Connection Cable (Included)

Product Name: **LCE08A-006** (For encoder)

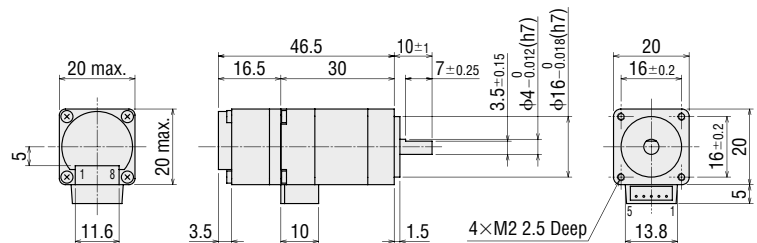

● These dimensions are for double shaft motors. For single shaft motors, ignore the shaded areas.

● Standard Type with Encoder

Frame Size 42 mm

Product Name	L	Mass kg
PKP543N18A2-R2GL	46.5	0.24
PKP544N18A2-R2GL	52.5	0.3
PKP545N18A2-R2GL	60.5	0.38
PKP546N18A2-R2GL	72.5	0.5

- Connection Cable (Sold separately)
Product Name: **LC5N06E** (For motor)
LCE08A-006 (For encoder)

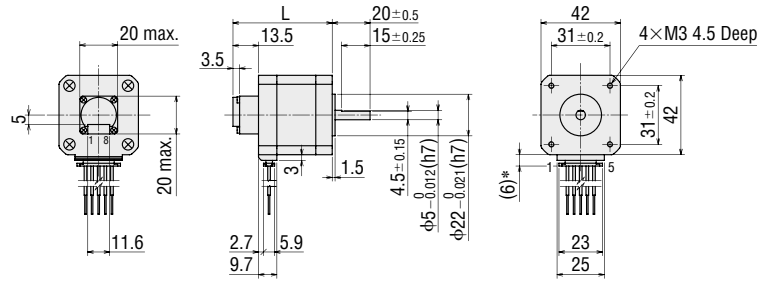

* With connection cable

● Standard Type with Encoder

Frame Size 56.4 mm

Product Name	L	Mass kg
PKP564N28A2-R2GL	55.5	0.43
PKP566N28A2-R2GL	70.5	0.67
PKP568N28A2-R2GL	92.5	1

- Connection Cable (Sold separately)
Product Name: **LC5N06E** (For motor)
LCE08A-006 (For encoder)

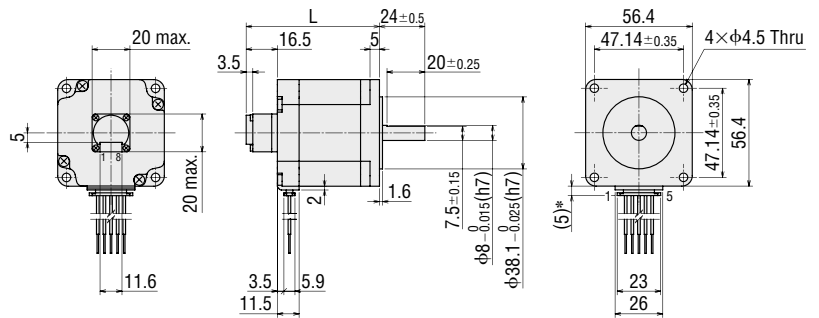

* With connection cable

● Standard Type with Encoder

Frame Size 60 mm

Product Name	L	Mass kg
PKP564FN24A2-R2GL	60.5	0.56
PKP564FN38A2-R2GL		
PKP566FN24A2-R2GL	72.5	0.79
PKP566FN38A2-R2GL		
PKP569FN24A2-R2GL	101	1.3
PKP569FN38A2-R2GL		

- Connection Cable (Sold separately)
Product Name: **LC5N06E** (For motor)
LCE08A-006 (For encoder)

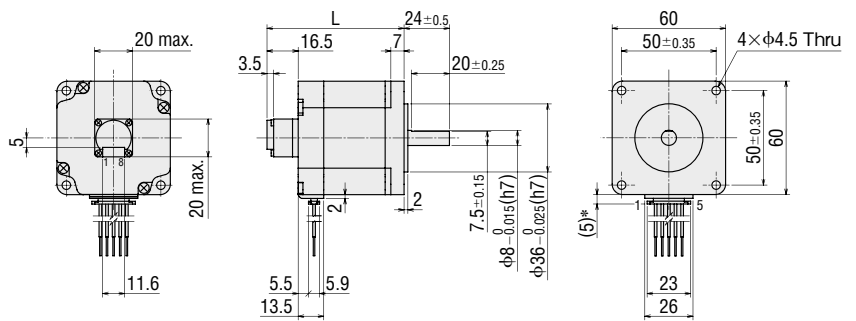

* With connection cable

● Driver

◇ Right Angle Type with an Installation Plate

Product Name	Mass kg
CVD205BR-K	0.06
CVD206BR-K	
CVD215BR-K	
CVD223BR-K	
CVD223FBR-K	
CVD228BR-K	
CVD503BR-K	
CVD512BR-K	
CVD518BR-K	
CVD524BR-K	

● Included

Connector Housing:	51103-0200 (Molex)
	51103-0500 (Molex)
	51103-1200 (Molex)
Contact:	50351-8100 (Molex)

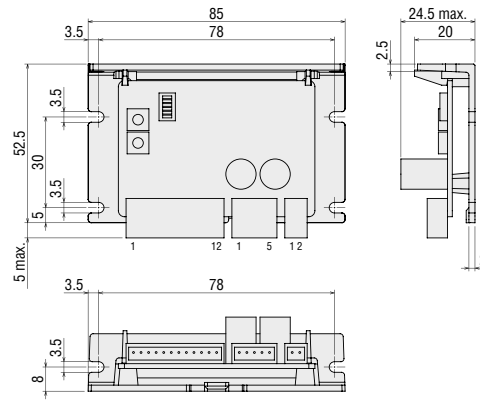

Product Name	Mass kg
CVD245BR-K	0.07
CVD528BR-K	
CVD538BR-K	

● Included

Connector Housing:	51067-0200 (Molex)
	51067-0500 (Molex)
	51103-1200 (Molex)
Contact:	50217-9101 (Molex)
	50351-8100 (Molex)

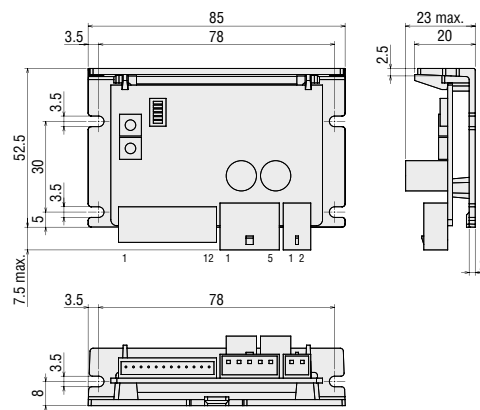

◇ With an Installation Plate

Product Name	Mass kg
CVD205B-K	0.06
CVD206B-K	
CVD215B-K	
CVD223B-K	
CVD223FB-K	
CVD228B-K	
CVD503B-K	
CVD512B-K	
CVD518B-K	
CVD524B-K	

● Included

Connector Housing:	51103-0200 (Molex)
	51103-0500 (Molex)
	51103-1200 (Molex)
Contact:	50351-8100 (Molex)

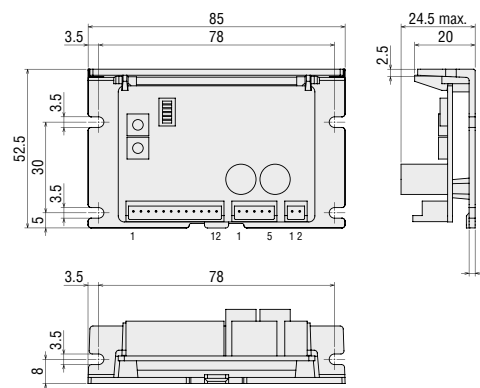

Product Name	Mass kg
CVD245B-K	0.07
CVD528B-K	
CVD538B-K	

● Included

Connector Housing:	51067-0200 (Molex)
	51067-0500 (Molex)
	51103-1200 (Molex)
Contact:	50217-9101 (Molex)
	50351-8100 (Molex)

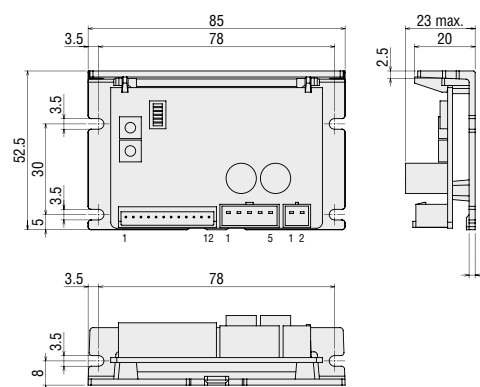

● As an accessory for DC input drivers, lead wires with a connector are available. These lead wires allow for easy connection of the motor, power supply and input/output signals. The connection cable set includes three connection cables (for motor, power supply and input/output signals).

● **Connection Cable**

A connection cable is required for connector-coupled motors.

◇ **Connection Cable for Motor (Sold separately)**

	Type	Frame Size	Product Name	Length L (m)
1.8° Stepper Motor	Standard Type	28 mm	LC2B06A	0.6
	Standard Type with Encoder	35 mm	LC2B06B	
	SH Geared Type	42 mm, 56.4 mm, 60 mm	LC2B06E	
0.72°/0.36° Stepper Motor	Standard Type	20 mm, 28 mm	LC5N06A	0.6
			LC5N10A	1
		42 mm, 56.4 mm, 60 mm	LC5N06E	0.6
	High-Resolution Type	42 mm	LC5N06B	1
			LC5N10B	1
		60 mm	LC5N06C	0.6
			LC5N10C	1

Product Name: **LC2B06A**

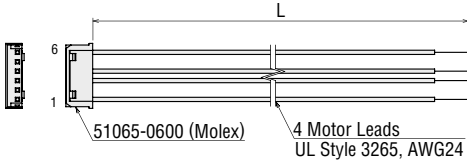

Product Name: **LC5N06A/LC510A**

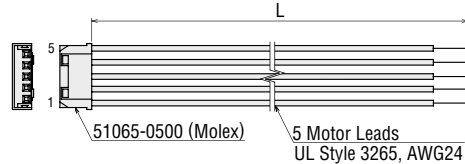

Product Name: **LC2B06B**

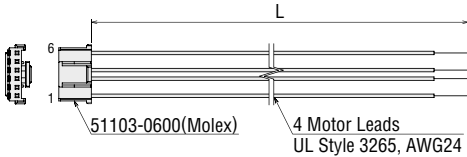

Product Name: **LC5N06B/LC5N10B**

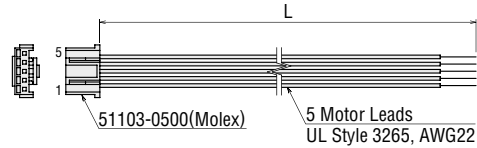

Product Name: **LC2B06E**

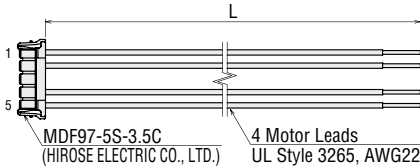

Product Name: **LC5N06C/LC5N10C**

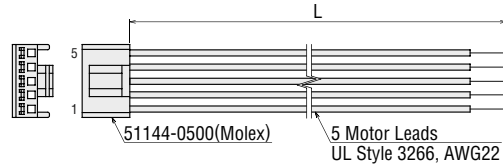

Product Name: **LC5N06E**

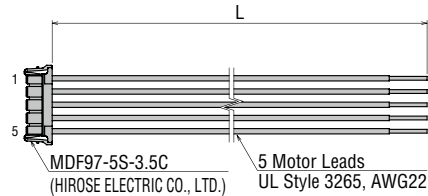

◇ **Connection Cable for Encoder (Sold separately)**

A connection cable for encoder is required for the type with an encoder.

Product Name	Length L (m)
LCE08A-006	0.6

Product Name: **LCE08A-006**

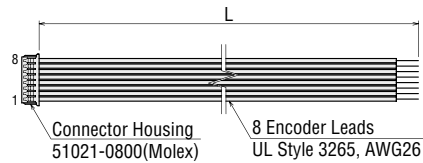

● **Applicable Connector**

The table below shows the applicable connectors.

◇ **Motor**

	Type	Frame Size	Connector Housing	Contact	Crimp Tool	
1.8° Stepper Motor	Standard Type	28 mm	51065-0600	50212-8100	57176-5000	(Molex)
	Standard Type with Encoder	35 mm	51103-0600	50351-8100	57295-5000	(Molex)
	SH Geared Type	42 mm, 56.4 mm, 60 mm	MDF97-5S-3.5C	MDF97-22SC	HT801/MDF97-22S	(HIROSE ELECTRIC CO., LTD.)
0.72°/0.36° Stepper Motor	Standard Type	20 mm, 28 mm	51065-0500	50212-8100	57176-5000	(Molex)
		42 mm, 56.4 mm, 60 mm	MDF97-5S-3.5C	MDF97-22SC	HT801/MDF97-22S	(HIROSE ELECTRIC CO., LTD.)
	High-Resolution Type	42 mm	51103-0500	50351-8100	57295-5000	(Molex)
		60 mm	51144-0500	50539-8100	57189-5000	(Molex)

◇ **Encoder (Molex)**

Connector Housing	Contact	Crimp Tool
51021-0800	50079-8100	57067-3000

Connection and Operation

Names and Functions of Driver Parts

1 Signal Monitor Indicators

◇ LED Indicator

Indication	Color	Function	Lighting Condition
PWR/ALM	Green	Power Supply Indication	When power is applied
	Red	Alarm Indication	When a protective function is activated (blinking)

◇ Alarm Contents

Blink Count	Function	Operating Condition
2	Overheat Protection	When the temperature of the driver board reaches 85°C
3	Overvoltage Protection	When the power supply voltage exceeds its permissible value
		When a large inertial load is stopped suddenly When a large load is hoisted
5	Overcurrent Protection	When an excessive current flows to the motor's output circuit
9	EEPROM Error	When data of the driver is damaged
Lighting	CPU Error	When a malfunction of CPU driver occurs

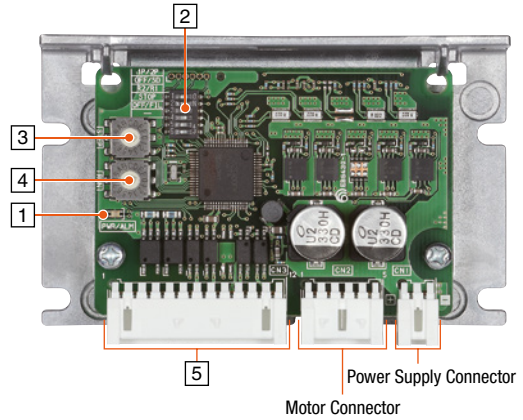

Power Supply Connector

Motor Connector

2 Function Setting Switch

Indication	No.	Function
1P/2P	1	Switches the pulse input mode between 1-pulse input mode and 2-pulse input mode.
OFF/SD	2	Switches the smooth drive function between enabled and disabled.
R2/R1	3	Use in combination with the step angle setting switch to set the step angle.
STOP	4	Switches the standstill current of motor to 25% or 50%.
OFF/FIL	5	Switches the command filter between enabled and disabled.
-	6	Not used.

● Difference in the Motor Responsiveness Depending on the Command Filter (OFF/FIL switch)

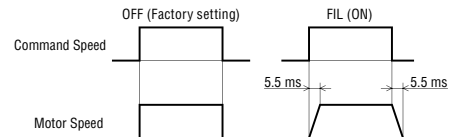

3 Step Angle Setting Switch

Indication	Function
STEP	Use in combination with the R2/R1 switch to set the step angle.

Step Angle Setting Switch (STEP) Scale	R2/R1 Switch: When Set to ON (R1)		R2/R1 Switch: When Set to OFF (R2)	
	Resolution (P/R)	Step Angle	Resolution (P/R)	Step Angle
0	500	0.72°	200	1.8°
1	1000	0.36°	400	0.9°
2	1250	0.288°	800	0.45°
3	2000	0.18°	1000	0.36°
4	2500	0.144°	1600	0.225°
5	4000	0.09°	2000	0.18°
6	5000	0.072°	3200	0.1125°
7	10000	0.036°	5000	0.072°
8	12500	0.0288°	6400	0.05625°
9	20000	0.018°	10000	0.036°
A	25000	0.0144°	12800	0.028125°
B	40000	0.009°	20000	0.018°
C	50000	0.0072°	25000	0.0144°
D	62500	0.00576°	25600	0.0140625°
E	100000	0.0036°	50000	0.0072°
F	125000	0.00288°	51200	0.00703125°

● Compared to standard type, the high-resolution type has 2 times the resolution and 1/2 the step angle.

Example: When R2/R1 switch is set to ON (R1)

and STEP switch is set to "0"

Resolution of High-Resolution Type: $500 \times 2 = 1000$

Step Angle of High-Resolution Type: $0.72/2 = 0.36^\circ$

4 Running Current Setting Switch

Indication	Function
RUN	Sets the motor running current.

5 I/O Signal Connector

Indication	Pin No.	I/O	Signal Name	Function
CN3	1	Input	PLS+ (CW+)	Operation command pulse signal (Rotates the motor in the CW direction when in 2-pulse input mode.)
	2		PLS- (CW-)	
	3		DIR+ (CCW+)	Rotation direction signal (Rotates the motor in the CCW direction when in 2-pulse input mode.)
	4		DIR- (CCW-)	
	5		AWO+	Stop motor excitation.
	6		AWO-	
	7	CS+	Switches the step angle.	
	8	CS-		
	9	Output	ALM+	Outputs the alarm status for the driver (normally closed).
	10		ALM-	
	11		TIM+	Output when the excitation state of the motor is step "0".
	12		TIM-	

Connection Diagram

When the pulse input is the line driver

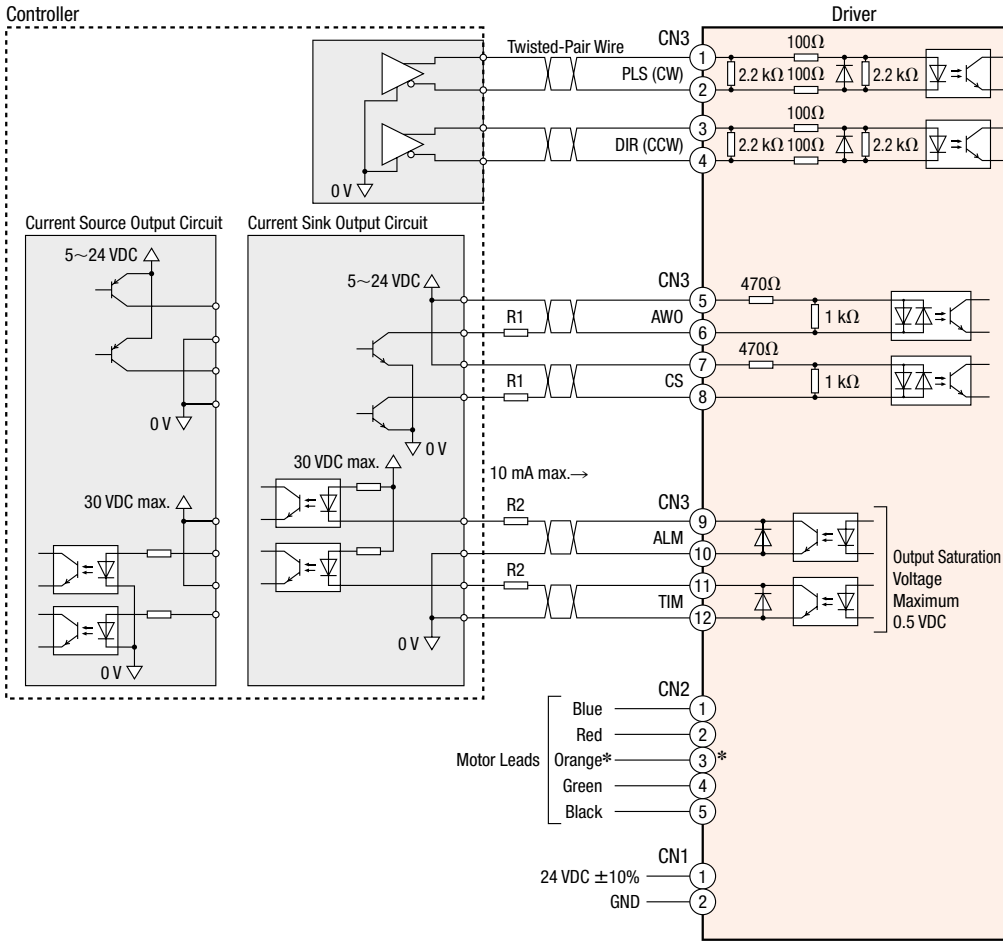

* This is not available for 1.8° Stepper Motor. Do not connect anything to pin No. 3.

When the pulse input is open collector

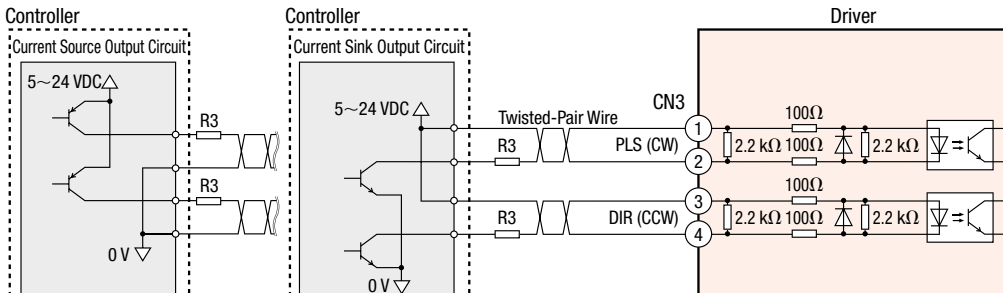

[Notes on Wiring]

◇ I/O Signal Connection

● Input Signal

Use 5 VDC for the input signals.

If voltage exceeding 5 VDC is applied, connect an external resistor R1 so that the current becomes 5~15 mA. (AWO, CS)

If voltage exceeding 5 VDC is applied to CW input and CCW input when the pulse input is open collector, connect an external resistor R3 so that the current becomes 7~20 mA.

● Output Signal

Use output signals at 30 VDC 10 mA max. When the current value exceeds 10 mA, connect an external resistor R2.

● Use twisted-pair cables of AWG24~22 (0.2~0.3 mm²).

● Note that as the length of the pulse line increases, the max. transmission frequency decreases, and keep the wiring length as short as possible (2 m max.).

● Provide a distance of 100 mm min. between the signal lines and power lines (such as power supply lines and motor lines).

◇ Power Supply Connection

● Use a wire of AWG22 (0.3 mm²). Use a wire of AWG20 (0.5 mm²) for **CVD245**, **CVD528** and **CVD538**.

● Incorrect polarities of the DC power-supply input will damage the driver. Make sure that the polarity is correct before turning the power on.

◇ Motor Cable Extension

● Use a wire of AWG22 (0.3 mm²) min. Use a wire of AWG20 (0.5 mm²) min. for **CVD245**, **CVD528** and **CVD538**.

◇ General

● A separate hand crimp tool is required to crimp the connector and lead wires included with the driver. Connection cables which are available as accessories (sold separately) have already had their lead wires crimped.

● If a specific wiring and layout causes the motor cable or power supply cable to generate a noise problem, shield the cable or use ferrite cores.

MCV Couplings

Features

- The anti-vibration rubber absorbs vibration from the motor.
- High Response
- Backlash 0
- Electrically insulated.



Product Number

MCV 30 08 14

① ② ③ ④

①	MCV Couplings
②	Outer Diameter of Coupling
③	Inner Diameter d1 (Smaller side) (06A represents $\phi 6.35$ mm)
④	Inner Diameter d2 (Larger side) (06A represents $\phi 6.35$ mm)

- For inner diameter d1, the smaller of the motor shaft diameter or the driven shaft diameter is entered.
- For inner diameter d2, the larger of the motor shaft diameter or the driven shaft diameter is entered.

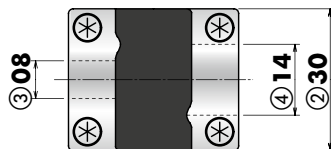

Product Line

Product Name	List Price
MCV15□	€50.00
MCV19□	€48.00
MCV25□	€53.00
MCV30□	€56.00
MCV34□	€61.00
MCV39□	€72.00

MCS Coupling

Features

- Backlash 0
- Provides high strength to geared motors.
- Vibration suppression effect



Product Number

MCS 30 10 12

① ② ③ ④

①	MCS Couplings
②	Outer Diameter of Coupling
③	Inner Diameter d1 (Smaller side) (F04 represents $\phi 6.35$ mm)
④	Inner Diameter d2 (Larger side) (F04 represents $\phi 6.35$ mm)

- For inner diameter d1, the smaller of the motor shaft diameter or the driven shaft diameter is entered.
- For inner diameter d2, the larger of the motor shaft diameter or the driven shaft diameter is entered.

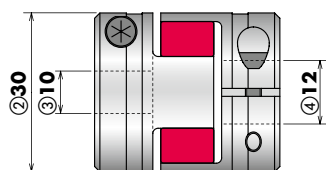

- For coupling selection, please see the selection table in our general catalogue or contact your nearest Oriental Motor sales office

Product Line

Product Name	List Price
MCS14□	€27.00
MCS20□	€30.00
MCS30□	€36.00
MCS40□	€55.00
MCS55□	€72.00
MCS65□	€115.00

- A number indicating the coupling inner diameter is entered where the box □ is located within the product name.

Motor Mounting Bracket

Mounting brackets are convenient for installation and securing a stepper motor.



● Product Line and List Price

Material: Aluminum alloy

Product Name	List Price	Motor Frame Size	Applicable Product
PFB28A	€12.00	28 mm	PKP22 □ PKP52 □
PAFOP PALOP		42 mm	PKP24 □ PKP54 □
PAL2P-2	€13.00	56.4 mm	PKP26 □ PKP56 □
PAL2P-5		60 mm	PKP56 □ F
PAL4P-2	€15.00	85 mm	PKP29 □
PAL4P-5		85 mm	PK59 □

- Names of applicable products contain characters that make product names identifiable.
- The mounting bracket base is built with holes large enough to allow for adjustments of belt tension after the motor is installed.
- These mounting brackets can fit to the pilot of

◇ SH Geared Type

Product Name	List Price	Motor Frame Size	Applicable Product
PFB28A	€12.00	28 mm	PKP223
SOLOA	€12.00	42 mm	PKP243
SOL2A	€12.00	60 mm	PKP264

Mounting Brackets for Circuit Products DIN Rail Installation

■ MADP

This is a DIN rail mounting bracket for board and box type drivers.

- Because it is made of metal, solid installation is possible.
- No horizontal slip even without an end plate.

● Product Line

Material: SPCC Surface treatment: Trivalent chromate

Product Name	List Price	Applicable Product
MADP01S1	€15.00	Bipolar Driver for 1.8°/0.9° Stepper Motor*1 Driver for 0.72°/0.36° Stepper Motor*1

*1 Without an installation plate



MADP01S1

Cables

Cable System Configuration

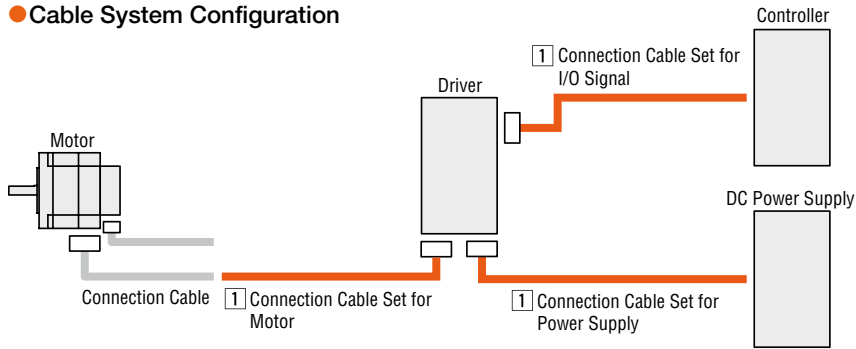

Connection Cable Sets

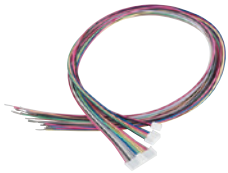

These are leads with connectors. Connecting with motors, input signal parts, and power supply parts is easy. The connection cable set includes three cables (for motor, I/O signal, and power supply).

Product Line

Product Name	Applicable Drivers	Length m	Conductor AWG	List Price
LCS01CVK2	CVD205, CVD206, CVD215, CVD223, CVD228	0.6	22 (0.3 mm ²)	€18.00
LCS02CVK2	CVD242, CVD245		20 (0.5 mm ²)*1 22 (0.3 mm ²)*2	€19.00
LCS04SD5	CVD503, CVD507 CVD512, CVD514 CVD518, CVD524		22 (0.3 mm ²)	€18.00
LCS05SD5	CVD528, CVD538		20 (0.5 mm ²)*1 22 (0.3 mm ²)*2	€19.00

*1 Cables for motors or DC power supplies
*2 Cables for I/O signals

Dimensions

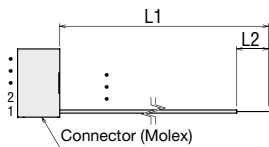

Connector array

◇ For Motor • LCS0□CVK2

Pin Number	Color
1	blue
2	red
3	-
4	green
5	black

• LCS0□SD5

Pin Number	Color
1	blue
2	red
3	orange
4	green
5	black

◇ For Power Supply • Common to all cables

Pin Number	Color
1	red
2	black

◇ For Input/Output Signals • Common to all cables

Pin Number	Color
1	brown
2	red
3	orange
4	yellow
5	green
6	blue
7	purple
8	gray
9	white
10	black
11	brown
12	red

Connection Cable (Extension)

These cables are used to extend the connection between bipolar connection motors and drivers.
When wiring the motor and the driver, keep a max. distance of 10 m.



Product Line

Product Name	Length (m)	Conductor AWG	Finished Outer Diameter mm	List Price
CC05PK5	5	22 (0.3 mm ²)	φ7.2	€33.00
CC10PK5	10			€65.00

Conductor configuration: 5 (Blue, Red, Orange, Green, Black)

- Cable rating: 105°C
- Outer casing: Oil-resistant, heat-resistant, non-migrating vinyl
- Applicable Product
Can be used with 1.8°/0.9° stepper motors with a rated current of 2.8 A max., and 0.72°/0.36° stepper motors with a rated current of 2.4 A max.

Motor Connector Set

This is a set of connector housings and contacts compatible with a connector-coupled motor.
Use this set if extra housings and contacts are necessary, although they are included with the products.

Product Line

Product Name	List Price	Applicable Product	
		0.72°/0.36° Stepper Motors	1.8°/0.9° Stepper Motors
CS5N30A	€40.00	PK513, PKP523, PKP525	—
CS5N30B	€40.00	PKP544M, PKP546M	—
CS5N30C	€45.00	PKP564FM, PK-P566FM, PKP569FM	—
CS2U30A	€40.00	—	PKP223, PKP225
CS2U30B	€40.00	—	PKP233, PKP235, PKP243M, PKP244M



This photograph shows **CS5N30B**.

- Each package contains enough housings and contacts for 30 motors.
Please order in units of 1 package.
The list price shows the price of 1 package.

Note

- A crimp tool is not included. Please prepare separately.

Circuit Product Cover

Product Line

Material: Resin

Product Name	List Price	Applicable Drivers
PADC-CVD	€10.00	CVD205BR-K, CVD206BR-K, CVD215BR-K, CVD223BR-K, CVD223FBR-K, CVD228BR-K, CVD242BR-K, CVD245BR-K, CVD503BR-K, CVD507BR-K, CVD512BR-K, CVD514BR-K, CVD518BR-K, CVD524BR-K, CVD528BR-K, CVD538BR-K

This is a protection cover to prevent contact with the circuit board.

Available for the right angle type driver with an installation plate.



<Application Example>

Controller

Universal Controller

SCX11 RoHS

The **SCX11** Universal Controller is a highly functional and sophisticated controller, equipped with program editing and execution functions. The **SCX11** is also able to control the motor via various serial ports such as USB, RS-232C and **CANopen**. Use the **SCX11** to support Oriental Motor's Pulse Input Type drivers.



Product Line

Product Name	Price
SCX11	€215.00

Features

- 100 Sequence Programs can be Stored
- Stored Program with GUI
- USB Connection to PC
- Various Interfaces for Operation
- External Encoder Input

Stand Alone Operation Using Sensors and Switches

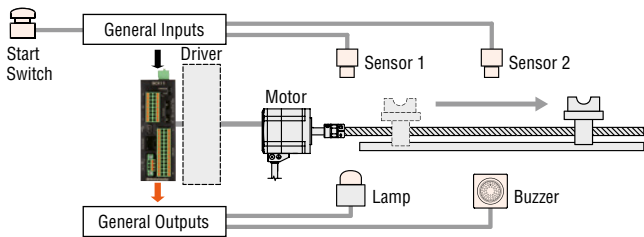

Various Interfaces for Operation

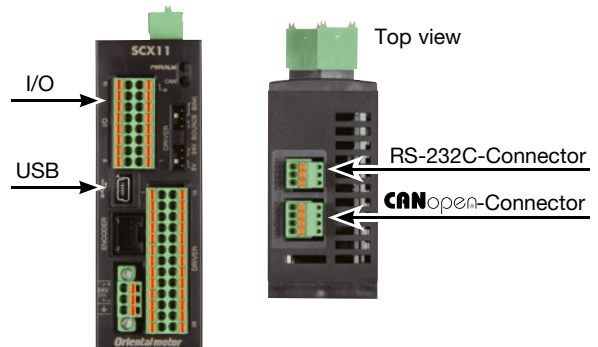

- Direct Command Operation via CANopen
- Operations Using a PC or PLC

**Bipolar Driver for 2-Phase Stepper Motors
Driver for 5-Phase Stepper Motors**

CVD Series
RS-485 Communication Type



Bipolar Drivers for 1.8°/0.9° Stepper Motors

Drivers for 0.36°/0.72° Stepper Motors

CVD Series RS-485 Communication Type

Product Number

CVD 2 B R - K R

① ② ③ ④ ⑤ ⑥

①	Series Name	CVD: CVD Series
②	Motor	2: 1.8°/0.9° Stepper Motor 5: 0.72°/0.36° Stepper Motor
③	Driver Type	B: With Installation Plate
④	Connector Type	R: Right Angle
⑤	Power Supply Input	K: DC Power Supply
⑥	Driver Type	R: RS-485 Communication Type

Product Line

Connector cable sets are available for the motor, power supply, I/O signals, and RS-485 communication (sold separately). The connectors are pre-crimped, making them easy to wire without crimp tools. For details, refer to page 2.

● Bipolar Driver for 1.8°/0.9° Stepper Motors

◇ Right Angle Type with Installation Plate

Product Name	List Price
CVD2BR-KR	148.00 €

◇ With Installation Plate

Product Name	List Price
CVD2B-KR	148.00 €

● Driver for 0.72°/0.36° Stepper Motors

◇ Right Angle Type with Installation Plate

Product Name	List Price
CVD5BR-KR	157.00 €

◇ With Installation Plate

Product Name	List Price
CVD5B-KR	157.00 €

Included

Type	Operating Manual
Common to all types	1 set

Specifications



Driver Product Name		CVD2B□-KR	CVD5B□-KR
Driving Method		Microstep Drive, Bipolar, Constant Current Drive Method	
Power Supply Voltage		24 VDC ± 10%	
Rated Current*		A	0.5 to 3.0 0.6 to 3.0
Interface	Direct Inputs	7, Photo-Coupler	
	Direct outputs	2, Photo-Coupler and Open-Collector	
	Communication	RS-485 (Modbus RTU)	
Operating Environment (In operation)	Ambient Temperature	0 to +50°C (Non-freezing)	
	Ambient Humidity	85% or less (Non-condensing)	
	Surrounding Atmosphere	No corrosive gas or dust. The product should not be exposed to water, oil or other liquids	

● For the right angle type with an installation plate, a code **R** (right angle) indicating the connector configuration is entered where the box □ is located within the driver product name.

*The input current value differs depending on the motor used together with the driver.

Refer to page 6.

RS-485 Communication Specifications

Electrical Characteristics	EIA-485 Based Use a shielded twisted pair cable, and keep the total wiring distance including extension to 10 m or less.
Communication Mode	Half duplex, asynchronous communication (data: 8 bits, stop bit: 1 bit or 2 bits, parity: none, even or odd)
Transmission Rate	Select either from 9600 bps, 19200 bps, 38400 bps, 57600 bps, 115200 bps, or 230400 bps.
Protocol	Modbus RTU Mode
Connection Units	Up to 31 drivers can be connected to a single host controller.

Dimensions (Unit: mm)

Right Angle Type with Installation Plate

Product Name	Mass [kg]
CVD2BR-KR	0.065
CVD5BR-KR	

● Applicable Connectors

Power Connector (CN1)

Connector Housing: 43645-0200 (Molex)

Contact: 43030-0001 (Molex)

Motor Connector (CN2)

Connector Housing: 51103-0500 (Molex)

Contact: 50351-8100 (Molex)

RS-485 Communication Connectors (CN4, CN5)

Connector Housing: PAP-03V-S (J.S.T. Mfg Co., Ltd.)

Contact: SPHD-001T-P0.5 or SPHD-002T-P0.5 (J.S.T. Mfg Co., Ltd.)

I/O Signal Connector (CN6)

Connector Housing: PHDR-12VS (J.S.T. Mfg Co., Ltd.)

Contact: SPHD-001T-P0.5 (J.S.T. Mfg Co., Ltd.)

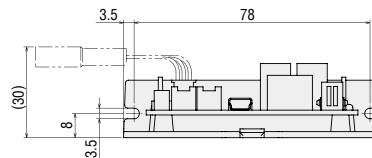
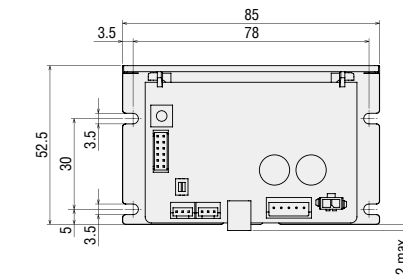
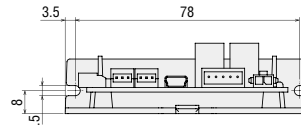
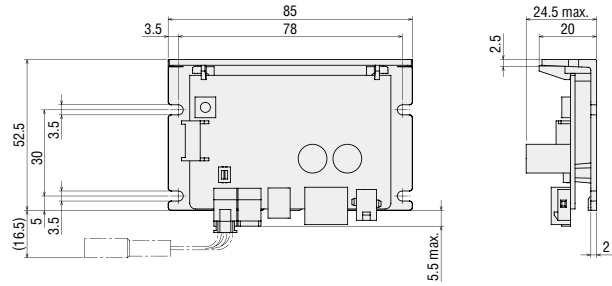

With Installation Plate

Product Name	Mass [kg]
CVD2B-KR	0.065
CVD5B-KR	

● Applicable Connectors

Applicable connectors are the same as the right angle type with installation plate.

● Connector cable sets are available for the motor, power supply, I/O signals, and RS-485 communication (sold separately). The connectors pre-crimped, making them easy to wire without crimp tools. For details, refer to page 6.

List of Applicable Motors

Driver for 1.8°/0.9° Stepper Motors

Driver Product Name		Rated Current	Input Current [A]	Applicable Motor
Right Angle Type with Installation Plate	With Installation Plate			
CVD2BR-KR	CVD2B-KR	0.5 A/Phase	0.5	PKP213D05 □
		0.6 A/Phase	0.5	PKP214D06 □
		0.85 A/Phase	0.8	PKP24 □ D08 □ 2
		1.4 A/Phase	1.3	PKP26 □ D14 □ 2
		1.5 A/Phase	1.9	PKP22 □ D15 □, PKP22 □ D15 □ 2
				PKP23 □ D15 □, PKP262FD15A
		2.3 A/Phase	2.0	PKP24 □ D15 □ 2 , PKP24 □ MD15 □ 2
		2.8 A/Phase	3.0	PKP23 □ D23 □, PKP24 □ D23 □ 2
		PKP25 □ D28 □ A2 , PKP26 □ D28 □ 2		
		PKP26 □ MD28 □ 2		

Driver for 0.72°/0.36° Stepper Motors

Driver Product Name		Rated Current	Input Current [A]	Applicable Motor
Right Angle Type with Installation Plate	With Installation Plate			
CVD5BR-KR	CVD5B-KR	0.35 A/Phase	0.6	PK513 , PK52 □ P
		0.75 A/Phase	1.4	PK52 □ H , PK54 □
		1.2 A/Phase	1.7	PKP52 □
		1.4 A/Phase	1.8	PK56 □
		1.8 A/Phase	2.8	PKP54 □ N18 □ 2 , PKP54 □ MN
		2.4 A/Phase	3.0	PKP56 □ FN24 □ 2 , PKP56 □ FMN

● A number indicating the length of the motor case is entered where the box □ is located within the names of the applicable motors.

● Either **A** (single shaft) or **B** (double shaft) indicating the configuration is specified where the box □ is located in the names of the applicable motors.

● Motors compatible with the driver are listed to easily distinguish motor and driver combinations.

Combinations with the encoder type and geared type are also available.

For details on the product name, please see the Oriental Motor website.

Note

● Keep the current setting of the driver to less than or equal to the rated current of the motor. If it exceeds the rated current of the motor, the product may be damaged.

Connection and Operation

Names and Functions of Driver Parts

1 Signal Monitor Indicators

◇ LED Indicator

Indication	Color	Function	Lighting Condition
PWR/ALM	Green	Power Supply Indication	When power is applied
	Red	Alarm Indication	When a protective function is activated (blinking)
C-DAT/C-ERR	Green	Communication Indication	When communication data is exchanged
	Red	Communication Error Indication	When a communication data error occurs

46

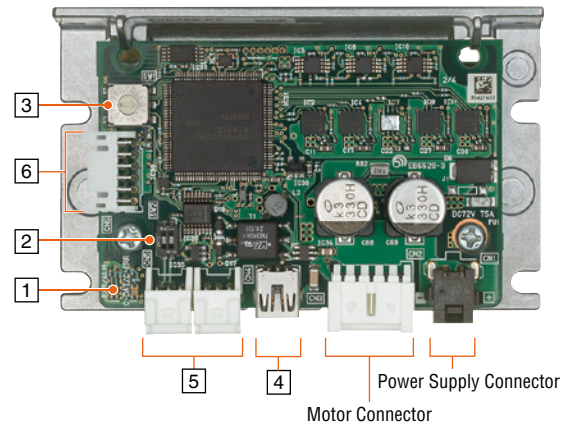

2 Terminating Resistor Setting Switch

Indication	No.	Function
SW2	1	Set the RS-485 communication termination resistor (120Ω) (Factory Setting: OFF) OFF: no termination resistor, ON: termination resistor connected.
	2	

3 Motor Setting Switch

Indication	Function
SW1	Sets the applicable motor (Factory Setting: 0)

4 USB Communication Connector (CN3)

◇ USB Communication Cable Specifications

Specification	USB 2.0 (Full Speed)
Cable	Length: 3 m or less
	Type: A to mini B

5 RS-485 Communication Connectors (CN4, CN5)

These connectors are used when controlled via RS-485 communication. Connect RS-485 communication cable (sold separately) to either CN4 or CN5 connector. Connect to another driver with the other connector.

Internal Input Circuit

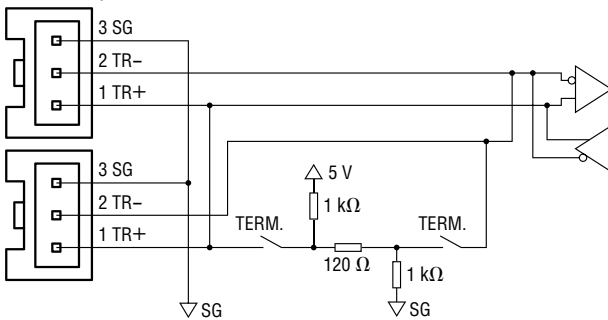

Pin No.	Signal Name	Function
1	TR+	RS-485 Communication Signal (+)
2	TR-	RS-485 Communication Signal (-)
3	SG	Signal GND

RS-485 Communication Cable



6 I/O Signal Connector (CN6)

Indication	Pin No.	Signal Name	Description
CN6	1	IN-COM	Input Common
	2	IN0	Control Input 0 [FW-POS] Execute continuous operation in the FWD direction.
	3	IN1	Control Input 1 [RV-POS] Execute continuous operation in the RVS direction.
	4	IN2	Control Input 2 [STOP] Stop the motor.
	5	IN3	Control Input 3 [ALM-RST] Alarm reset.
	6	IN4	Control Input 4 [HOMES] Input for mechanical home sensor.
	7	IN5	Control Input 5 [FW-LS] Input for a limit sensor in FWD direction.
	8	IN6	Control Input 6 [RV-LS] Input for a limit sensor in RVS direction.
	9	OUT0	Control Output 0 [ALM-B] Driver alarm status output (normally closed).
	10	OUT1	Control Output 1 [TIM] Output when the excitation state of the motor is step "0".
	11	OUT-COM	Output Common
	12	N.C.	N.C.

Connection Diagrams

Connecting to a Current Sink Output Circuit

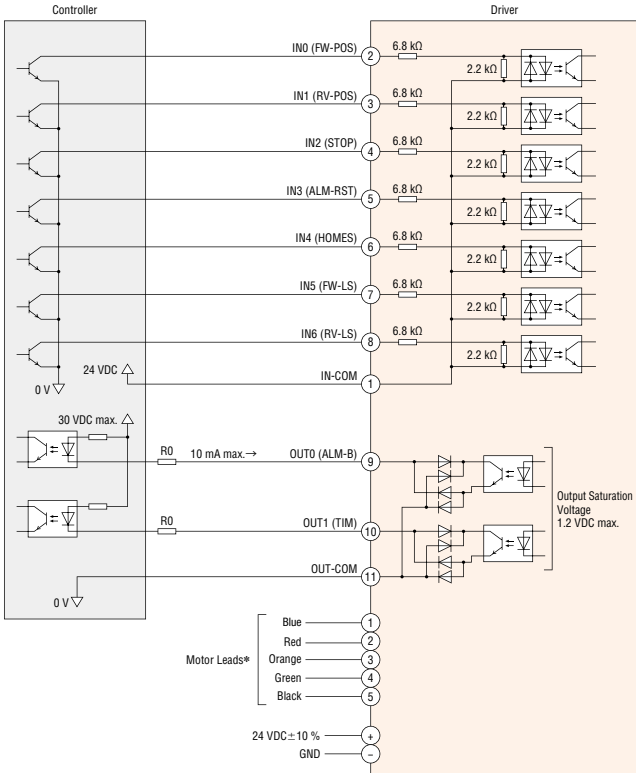

*The connector pin assignments vary depending on the motor. For details, refer to the connection table on page 5.

Connecting to a Current Source Output Circuit

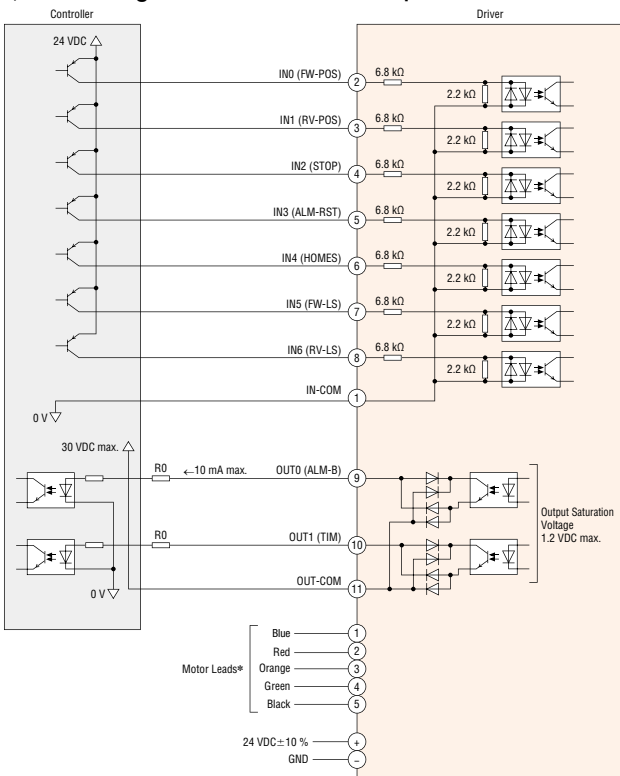

*The connector pin assignments vary depending on the motor. For details, refer to the connection table on page 5.

[Note on Wiring]

◇ I/O Signal Connection

- Use output signals at 30 VDC or less, 10 mA or less. When the current value exceeds 10 mA, connect an external resistor R0.
- For the I/O signals cable, using a twisted pair cable or a shielded cable is recommended.
- Keep the wiring distance as short as possible (less than 2 m) to limit the effect of noise.
- Provide a distance of 100 mm or more between the control I/O signal lines and power lines (power supply lines, motor lines and other large-current circuits).

◇ Power Supply Connection

- Reverse-polarity connection of DC power supply input may cause damage to the driver. When connecting, be sure to check the polarity of the power supply.

◇ Motor Connection

- Up to three cables can be used for the connection between the motor and driver.
- Keep 10 m or less for the wiring distance between the motor and driver.

◇ General

- A separate hand crimp tool is required to crimp the connector and lead wires included with the driver. Connection cables which are available as accessories (sold separately) have already had their lead wires crimped.
- If a specific wiring and layout causes the motor cable or power supply cable to generate a noise problem, shield the cable or use ferrite cores.

◇ Connection Table for 2-Phase CVD Driver

- Motor: 0.9°/1.8° PKP/PK Series Bipolar 4 Leads
- Driver: Bipolar Driver for 0.9°/1.8° Stepper Motors

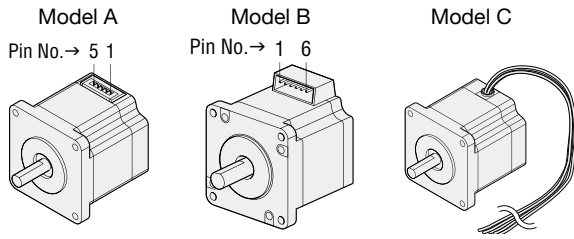

Driver CN2 Pin No.	Model A		Model B		Model C
	Pin No.	Color	Pin No.	Color	Color
1	4	Blue	1	Blue	Blue
2	5	Red	3	Red	Red
3	-	-	-	-	-
4	2	Green	6	Green	Green
5	1	Black	4	Black	Black

● The Colors in the table represent colors of the lead wires of the connection cables sold separately.

Note

● The motors shown in the model A and model B have different pin assignments. Incorrect connection will prevent the motor from operating correctly.

◇ Connection Table for 5-Phase CVD Driver

- Motor: 0.36°/0.72° PKP/PK Series
- Driver: Bipolar Driver for 0.36°/0.72° 0.36°/0.72° Stepper Motors

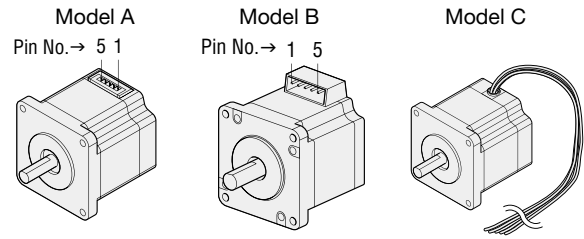

Driver CN2 Pin No.	Model A		Model B		Model C
	Pin No.	Color	Pin No.	Color	Color
1	5	Blue	1	Blue	Blue
2	4	Red	2	Red	Red
3	3	Orange	3	Orange	Orange
4	2	Green	4	Green	Green
5	1	Black	5	Black	Black

● The Colors in the table represent colors of the lead wires of the connection cables sold separately.

Power Supply Cable/I/O Signal Cable Set (for RS-485 Communication Type)

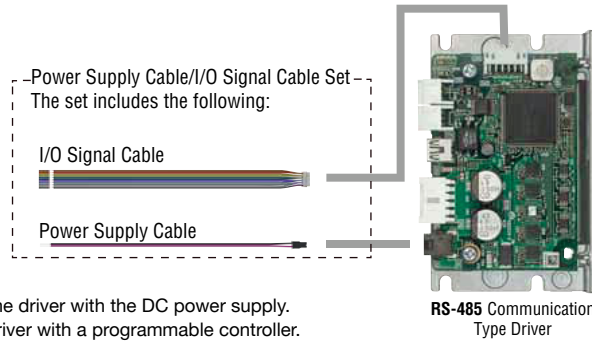

The power supply cable is for connecting the driver with the DC power supply.
The I/O signal cable is for connecting the driver with a programmable controller.
Power supply cable and I/O signal cable are coming as a set.

Product Line

Product Name	Length L [m]	List Price
LHS003CC	0.3	6.50 €
LHS010CC	1	8.00 €

Dimensions (Unit: mm)

Power Supply Cable

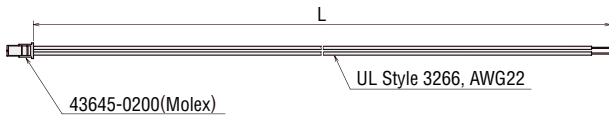

I/O Signal Cable

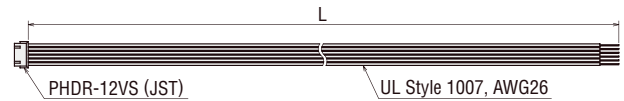

RS-485 Communication Cable (for RS-485 Communication Type)

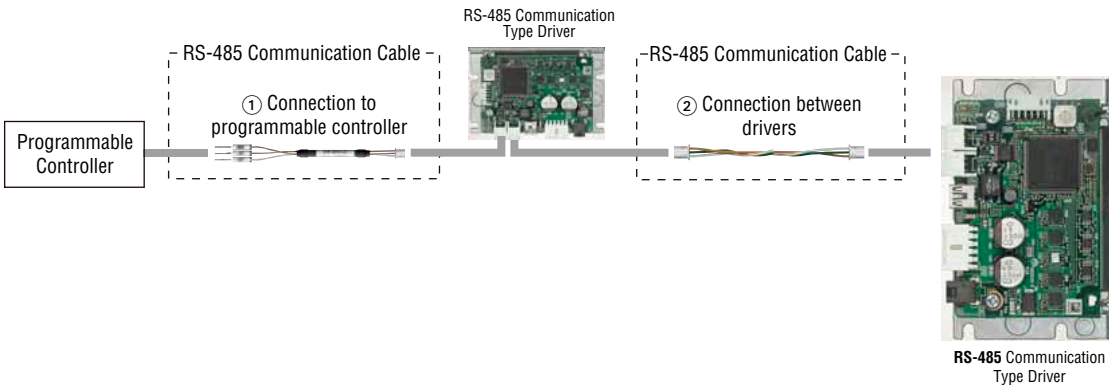

① For Connection to Programmable Controller
Cable for connection to a programmable controller.

Product Line

Product Name	Length L [m]	List Price
CC030-RS	3	19.00 €

Dimensions (Unit: mm)

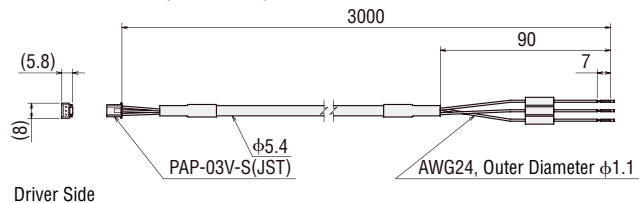

② For Connection between Drivers
Cable for connection between drivers.

Product Line

Product Name	Length L [m]	List Price
LH0015-RWN	0.15	9.00 €

Dimensions (Unit: mm)

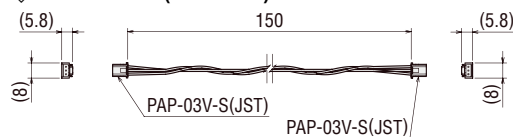

Orientalmotor

These products are manufactured at plants certified with the international standards **ISO 9001** (for quality assurance) and **ISO 14001** (for systems of environmental management).

Specifications are subject to change without notice. This catalogue was published in December 2020.

ORIENTAL MOTOR (EUROPA) GmbH

www.orientalmotor.de

European Headquarters

Schießstraße 44
40549 Düsseldorf, Germany
Tel: 0211-520 670 0 Fax: 0211-520 670 99

Spanish Office

C/Caléndula 93 - Ed. E - Miniparc III
28109 El Soto de La Moraleja,
Alcobendas (Madrid), Spain
Tel: +34 918 266 565
www.orientalmotor.es



ORIENTAL MOTOR (UK) LTD.

www.oriental-motor.co.uk

UK Headquarters

Unit 5, Faraday Office Park,
Rankine Road, Basingstoke,
Hampshire RG24 8AH, U.K.
Tel: 01256-347 090 Fax: 01256-347 099



ORIENTAL MOTOR SWITZERLAND AG

www.orientalmotor.ch

Switzerland Headquarters

Badenerstrasse 13
5200 Brugg AG, Switzerland
Tel: 056-560 504 5 Fax: 056-560 504 7



ORIENTAL MOTOR ITALIA s.r.l.

www.orientalmotor.it

Italy Headquarters

Via XXV Aprile 5
20016 Pero (MI), Italy
Tel: 02-939 063 46 Fax: 02-939 063 48



ORIENTAL MOTOR (FRANCE) SARL

www.orientalmotor.fr

France Headquarters

56, Rue des Hautes Pâtures
92000 Nanterre, France
Tel: 01-478 697 50 Fax: 01-478 245 16



Other countries: www.orientalmotor.eu

Customer Service Center (Support in German & English)

00800-22 55 66 22*
CA LL OM CC

Mon-Thu: 08:00 - 17:30 CET Friday: 08:00 - 16:00 CET

*Free Call Europe

info@orientalmotor.de

For more information please contact: