

Orientalmotor

(RoHS) RoHS-Compliant

2-Phase Stepping Motor

PK Series

High-Torque Type

Frame Size **20 mm**

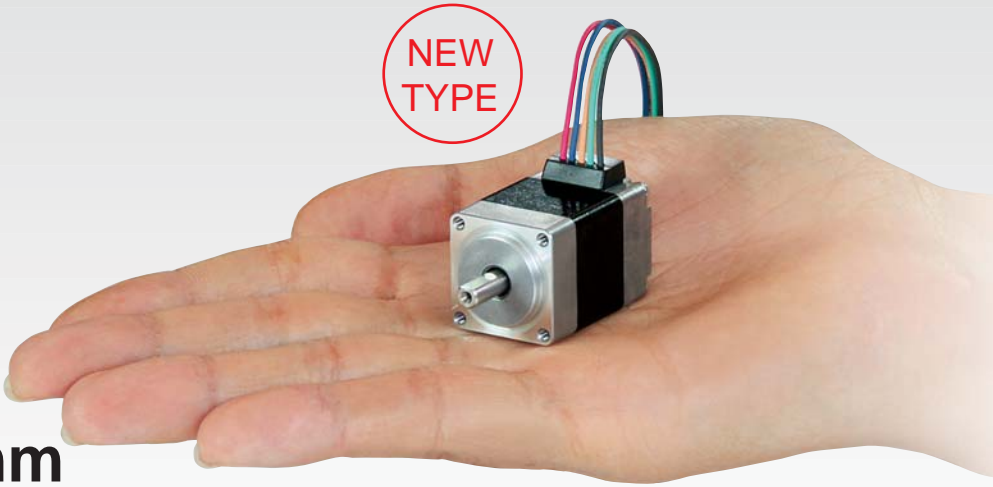

Oriental Motor launches a new 2-Phase stepping motor with 20 mm frame size. The new type offers a small and lightweight body combined with high torque technology.

Features

Very small and lightweight

With 20 mm frame size and 50 g mass the new type is the smallest motor of the **PK Series** and is perfectly made for applications with few space.

Actual Size

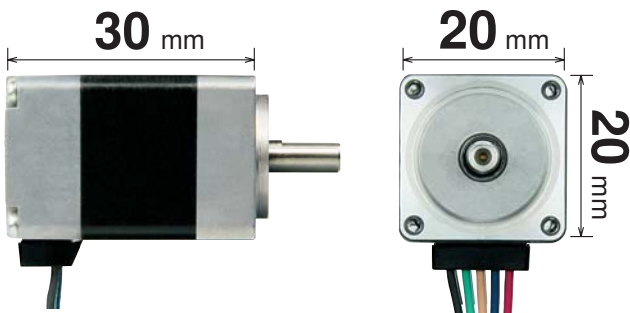

Mass **50 g**

High-Torque

This 2-Phase stepping motor adopts Oriental Motor's high torque technology.

Maximum Holding Torque

Model	Connection Type	Maximum Holding Torque
PK213PD□	Bipolar	0.020 N·m
PK213P□	Unipolar	0.014 N·m

Product Lineup

Bipolar 4 Leads

Model (Single Shaft)	Model (Double Shaft)
PK213PDA	PK213PDB

Unipolar 5 Leads

Model (Single Shaft)	Model (Double Shaft)
PK213PA	PK213PB

Specifications **(RoHS)**

Model		Holding Torque N·m	Rotor Inertia J:kg·m ²	Rated Current A/Phase	Voltage V	Resistance Ω/Phase	Basic Step Angle	Motor Mass kg
Single Shaft	Double Shaft							
PK213PDA	PK213PDB	0.02	1.6×10 ⁻⁷	0.5	4.25	8.5	1.8°	0.05
PK213PA	PK213PB	0.014	1.6×10 ⁻⁷	0.5	4.25	8.5	1.8°	0.05

Speed-Torque Characteristics

fs: Maximum Starting Frequency

Bipolar 4 Leads

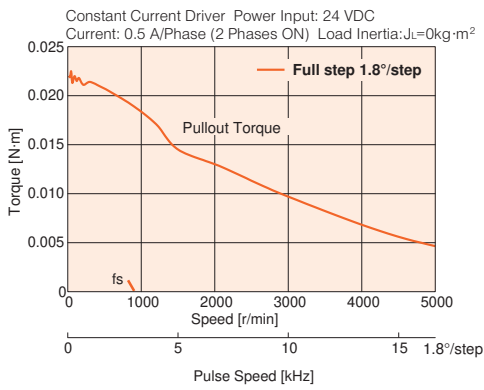

Unipolar 5 Leads

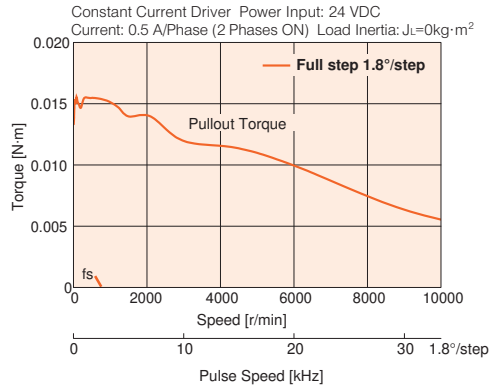

Dimensions (Unit = mm)

Bipolar 4 Leads

Mass: 0.05 kg

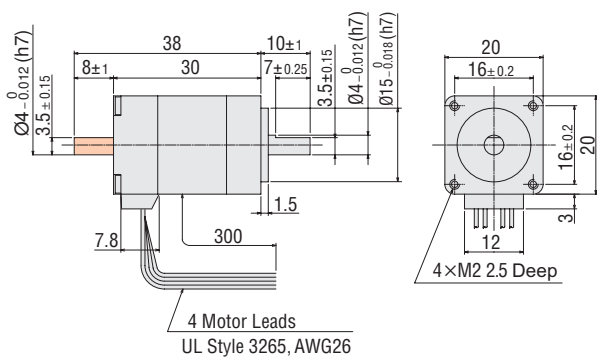

- These dimensions are for double shaft models.
- For single shaft models, ignore the orange () areas.
- For available driver please contact the nearest sales office.

Connection

PK21□P

Connect the motor according to the wiring diagram.

Wiring diagram

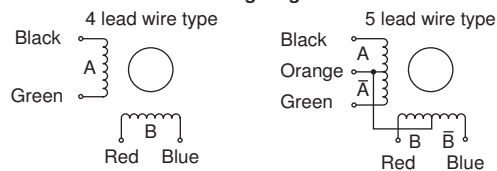

Unipolar 5 Leads

Mass: 0.05 kg

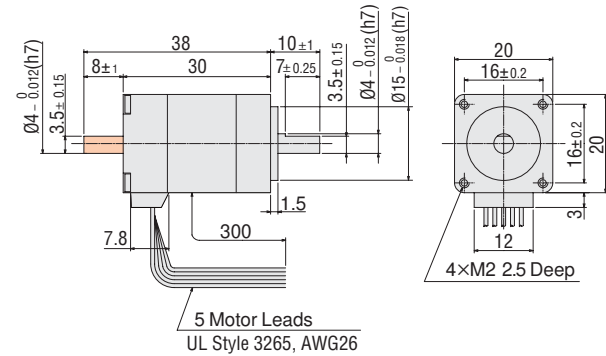

This product is manufactured at a plant certified with the international standards **ISO 9001** (for quality assurance) and **ISO 14001** (for systems of environmental management).

Specifications are subject to change without notice.

This catalogue was published in November, 2009.

Orientalmotor

ORIENTAL MOTOR (EUROPA) GmbH
www.orientalmotor.de

European Headquarters and Düsseldorf Office
Schiessstraße 74
40549 Düsseldorf, Germany
Tel: 0211-5206700 Fax: 0211-52067099

ORIENTAL MOTOR (FRANCE) SARL
www.orientalmotor.fr

France Headquarters
32, Avenue de l'île Saint Martin
92737 Nanterre Cedex, France
Tel: 01 47 86 97 50 Fax: 01 47 82 45 16

ORIENTAL MOTOR (UK) LTD.
www.oriental-motor.co.uk

Unit 5, Faraday Office Park,
Rankine Road, Basingstoke,
Hampshire RG24 8AH U.K.
Tel: 01256-347090 Fax: 01256-347099

ORIENTAL MOTOR CO., LTD.
www.orientalmotor.co.jp

Headquarters
16-17, Ueno 6-chome
Taito-ku, Tokyo 110-8536, Japan
Tel: (03)3835-0684 Fax: (03)3835-1890

ORIENTAL MOTOR ITALIA s.r.l.
www.orientalmotor.it

Italy Headquarters
Via A. De Gasperi, 85
20017 Mazzo di Rho (MI), Italy
Tel: 02-93906346 Fax: 02-93906348

For more information please contact: