

Orientalmotor

Brushless Motors
BLV Series
R Type

Products for Modular Automation

**Battery-operated, Compact, and Lightweight Brushless
DC Motors in the Era of Advancing Automation**



100 W
200 W

DC
Input

High-power, Compact Brushless DC Motors. Developed to Support the Design of Compact, Battery Driven Automation.

Brushless DC Motors **BLV Series R Type**

- Output Power: 100 W, 200 W
- Power supply input: 24~48 VDC
- Electromagnetic brake type available

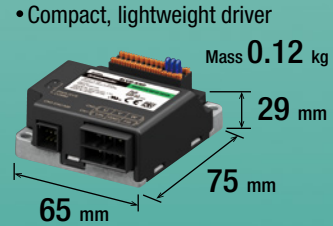

Compact, Lightweight, and High-power Designed for Compact Equipment

P.4



Transportation robots for flat, transportable masses can be designed

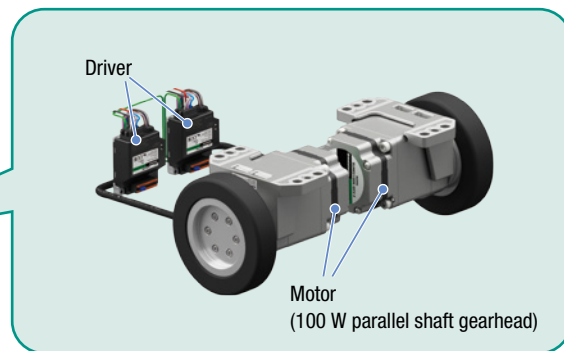

Wide Speed Range, Smooth Motion, Current Position and Position Feedback is Possible.

P.5

- Wide speed control range of 1~4000 r/min. Smooth performance is possible throughout the entire speed range.
- Current position and position feedback is possible through high motor resolution.

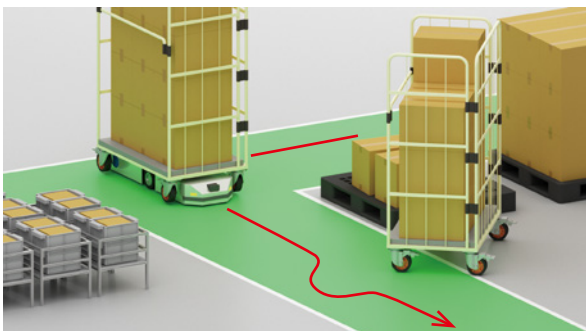

Smooth performance while avoiding obstacles

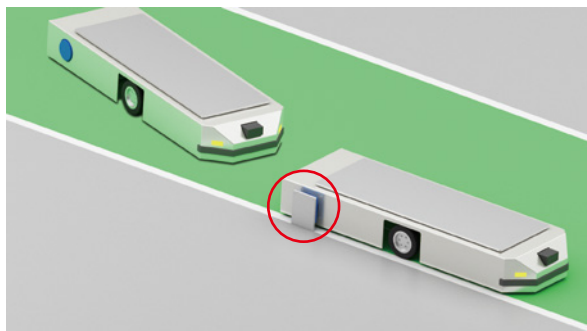

Ability to stop at a target position, charging station or load loading station is possible.

What are “Products for Modular Automation”?

“Products for Modular Automation” is a product group with a shared concept of battery-operated, compact, and lightweight products. Optimal for self-propelled equipment. These products meet the needs of flexible automation lines and modular automation.

Modbus (RTU)
CANopen



Driver



Parallel Shaft Gearhead

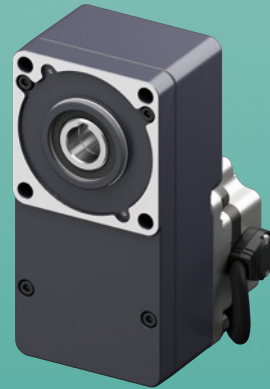

Hollow Shaft Flat Gearhead



Round Shaft

An Increased Range of Operating Voltages Supports Real World Battery Use.

P.6

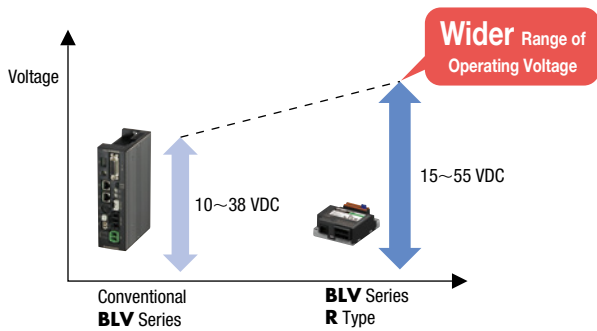

Operation is possible even if the voltage drops

Recommended Features

P.7

- Holding position when stopped is possible without an electromagnetic brake
- ATL function that automatically limits output torque
- Two motor cable output directions to choose from

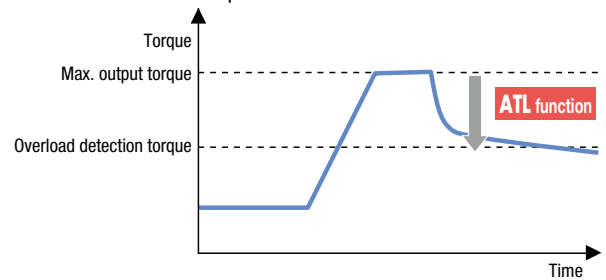

Avoid motor stalling due to overload

Compatible with Modbus (RTU) and CANopen Communication

P.8

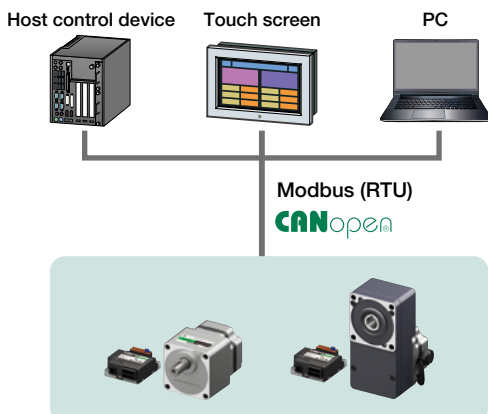

Supporting Startup, Operation, and Maintenance BLST01 Support Software

P.9-10

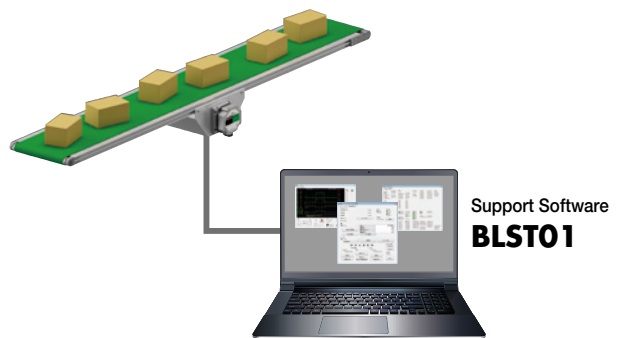

Check operating conditions with various monitors

Compact, Lightweight, and High-power

Designed for Compact Equipment

Compact & Lightweight

Both the motor and driver are significantly smaller and lighter.

The driver is approximately 80% smaller than a conventional product. The smaller driver saves valuable space in the automation equipment.

● Motor*

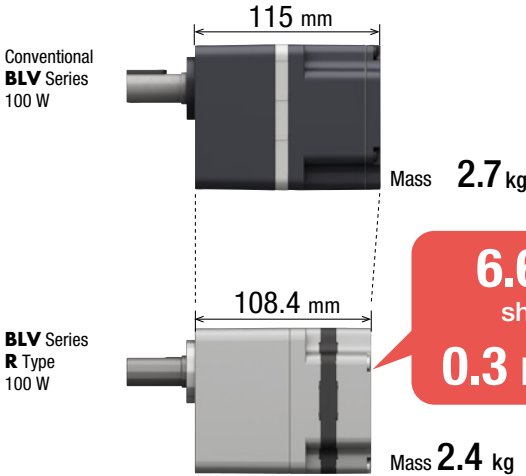

● Driver

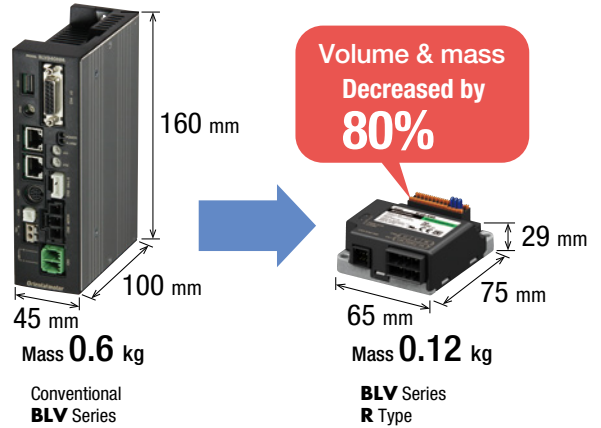

*For a 100 W parallel shaft gearhead at a gear ratio of 30

Powerful

The new motor allows for larger inertia loads and heavier products to be transported compared to a conventional product.

This also contributes to compact, high-power equipment design.

[Example design of a transportation robot]

Operating Conditions

BLV Series R Type Motor	Product Line	Parallel Shaft Gearhead
	Output Power	100 W
Gear Ratio	30	
Driving Conditions	Wheel Diameter	120 mm
	No. of Drive Wheels	2
	Acceleration Time	1 second

Results

Max. Load Mass (Transportation robot mass + Load mass)	150 kg*
Maximum Traveling Speed	0.6 m/sec

* Rolling resistance coefficient 0.1



Large Inertial Loads Can be Moved

-Image of inertial load (reference)-

Inertia: $20,700 \times 10^{-4} \text{ kg}\cdot\text{m}^2$
(Diameter: 470 mm, thickness: 50 mm, material: iron)

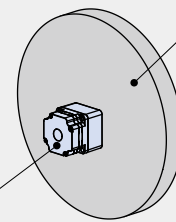

100 W parallel shaft gearhead, gear ratio 30
(Frame size: 90 mm, motor length: 108.4 mm)

● When the deceleration time is set to 0.1 seconds or higher

Wide Speed Range, Smooth Motion, Current Position and Position Feedback is Possible

Broad speed control range of 1~4000 r/min

A smooth start and stop is possible due to stable operation, even in the low speed range from 1 r/min.

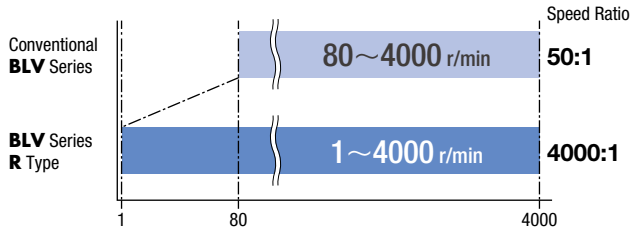

Merit

• Smooth operation even in applications where small obstacles may need to be avoided.

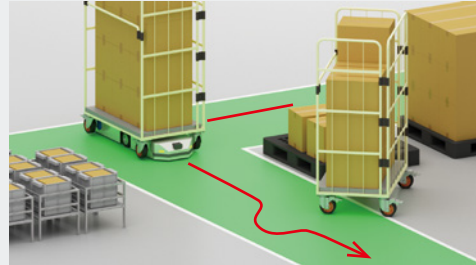

High speed stability when operated at high speed

Operation at the set speed is possible even with load fluctuation due to accurate speed regulation (*1) of $\pm 0.01\%$.

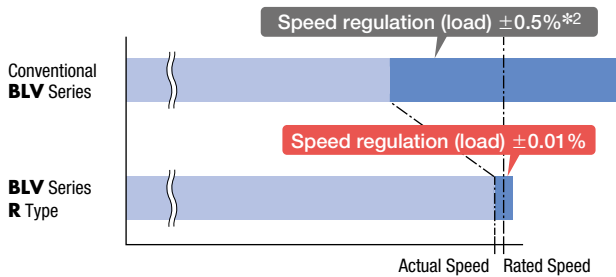

*1 Rate of change in speed when a constant load is applied

$$\text{Speed regulation} = \frac{\text{Actual speed} - \text{Command speed}}{\text{Rated speed}} \times 100 (\%)$$

*2 $\pm 0.2\%$ for digital settings

Positioning operations and position reading are possible

The current position can be acquired with enhanced motor feedback information.

Improved resolution allows the motor to stop at the target position.

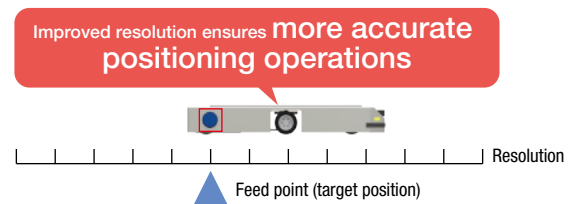

Wider Operating Voltage Range

Supports Real World Battery Use.

Wider Operating Voltage Range

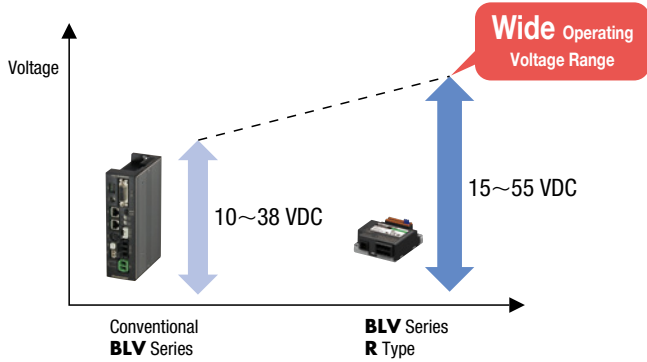

Advantages

- Compatible with 24~48 VDC batteries.
- Will not stop even if the battery voltage drops. Continues operating while limiting the speed and torque.

● The driver's overvoltage alarm threshold is 63 VDC.

Power Consumption Reduced by 10%

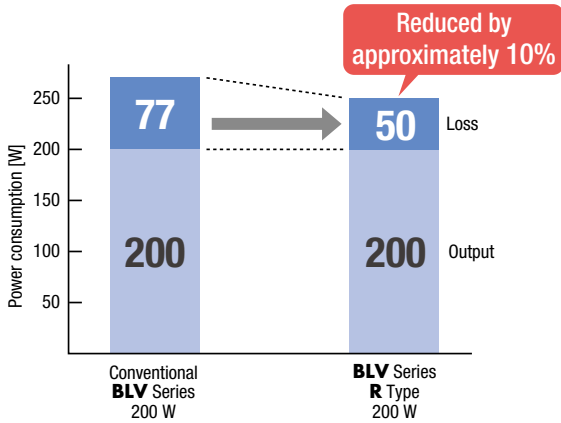

Advantages

- Extended travel distance and time for transportation robots. The number of battery charges can also be decreased.
- Power consumption can be monitored via the **BLSTO1** Support Software and communication. This is useful as a charging reference.

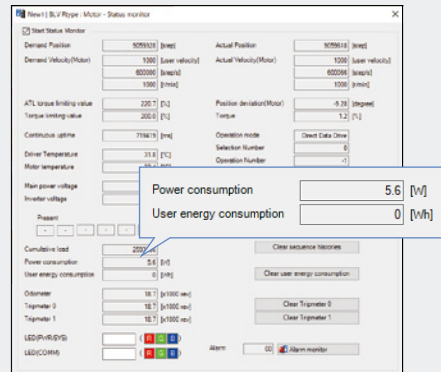

Various Recommended Features

Holding Position when Stopped is Possible without an Electromagnetic Brake

When the motor has stopped in an excitation state, it can be used as an electrical holding brake even without a mechanical brake. The motor enters an excitation state when the input signal “S-ON” is turned ON, and generates holding force. (Servo ON) When the input signal “P-LOOP-MODE” is turned ON, the position can be held with no deviation from the stop position.

Note

If the power supply to the driver is turned OFF, the holding force dissipates. This cannot be used to prevent free movement during a power outage.

ATL Function that Automatically Limits Output Torque

The ATL function limits torque and ensures that the motor does not stop when an overload alarm occurs, even when torque continues to be output at a level at which an overload alarm is detected.

The motor will continue driving even if an unexpected overload occurs*.

*Examples

- Runs into an obstacle
- Sudden acceleration command
- Carrying a load exceeding the transportable mass

● Please disable the ATL function if the motor should stop when an alarm is output during overload.

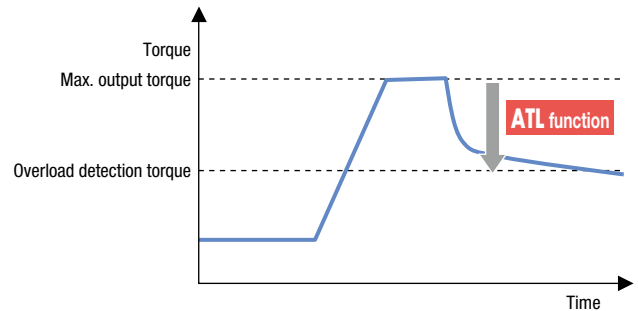

Cable Output Direction Options

There are two motor cable output directions to choose from to best fit installation requirements.

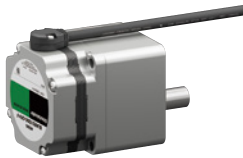

Cable in shaft direction



Cable opposite to shaft direction

● Suitable for various applications, including transportation robots.

Transportation robot

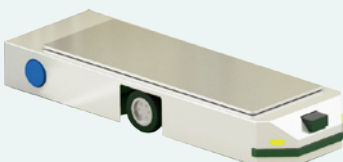

Agitator

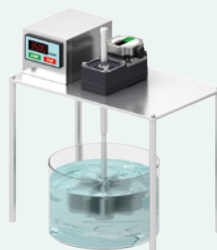

Conveyor

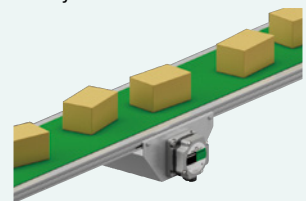

Compatible with Modbus (RTU) and CANopen Communication

The **BLV Series R** Type is compatible with Modbus (RTU) and CANopen communication interfaces.

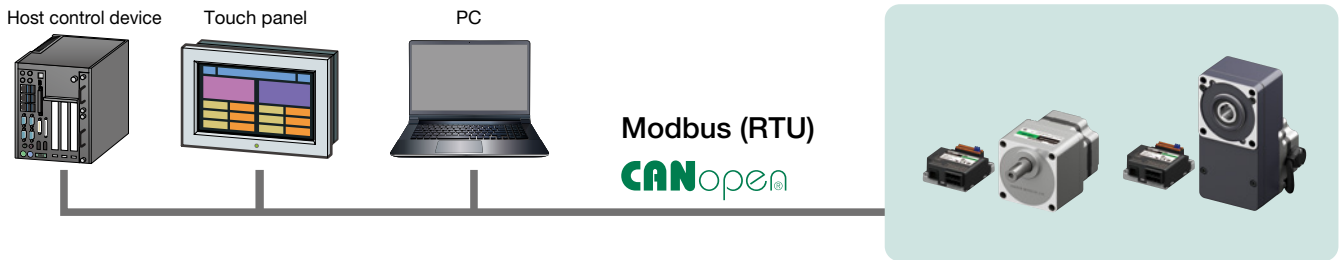

Primary Modbus (RTU) Functions

● Create Operation Profiles - Direct Data Operation

With Modbus (RTU) communication, data can be rewritten and operations can be started at the same time.

● Types of Operating Data

Operating Modes	Sets the operating mode.
Position	Sets the target position.
Speed	Sets the operating speed.
Acceleration Rate	Sets the acceleration time.
Deceleration Rate	Sets the deceleration time.
Torque Limiting Value	Sets the torque limiting value.

● Collect, Send, and Receive Data Across Different Axes - ID Share Mode

This function improves synchronization between axes with Modbus (RTU) communication.

Data collected from multiple axes can be sent and received, shortening the communication delay between axes.

It can also be used to send different commands to each axis at the same time.

This transmission method is unique to Oriental Motor.

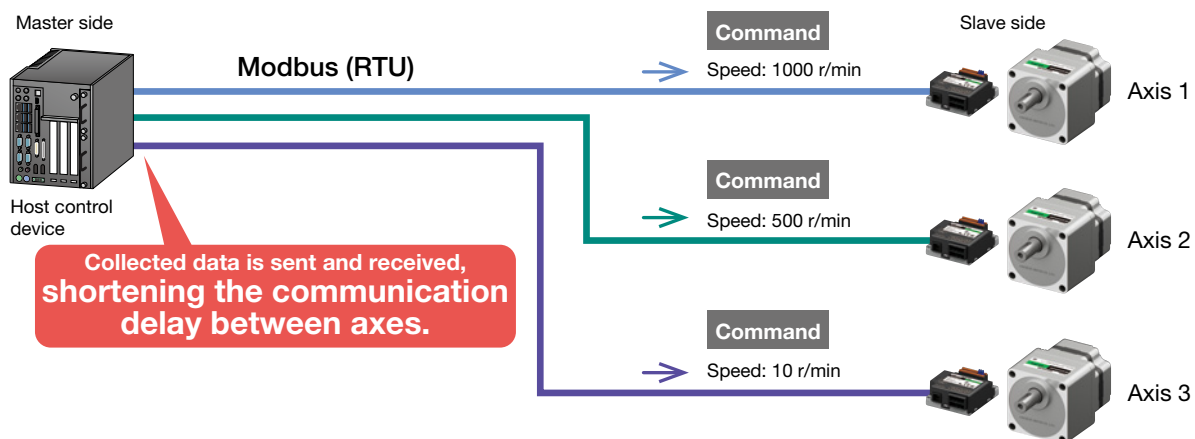

Supporting Startup, Operation, and Maintenance

with the **BLST01** Support Software

By using the **BLST01** Support Software, data setting, operation, and status confirmation via each monitor can be performed easily on a computer. The support software can be downloaded for free from the Oriental Motor website.



Support Software
BLST01

Startup Functions that Support Programming at Setup

Simple Settings

Various communication settings can be easily made using the “Simple communication settings”.

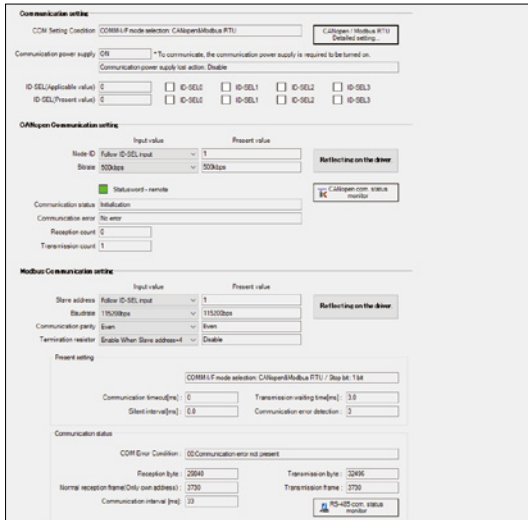

Communication Frame Monitoring, Communication Status Monitoring

All communication frames and statuses can be monitored. This is useful for host program startup and debugging.

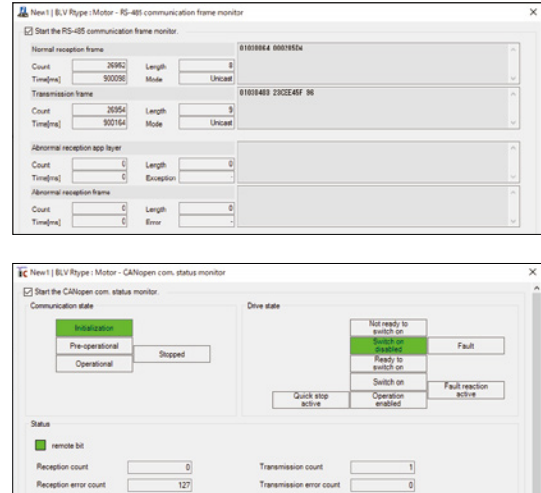

Operation Functions that Support Fine Tuning

Waveform Monitoring

The operating status of the motor (command speed, torque, I/O signal, etc.) can be checked like with an oscilloscope. Waveform measurement results can be saved as images and in CSV format.

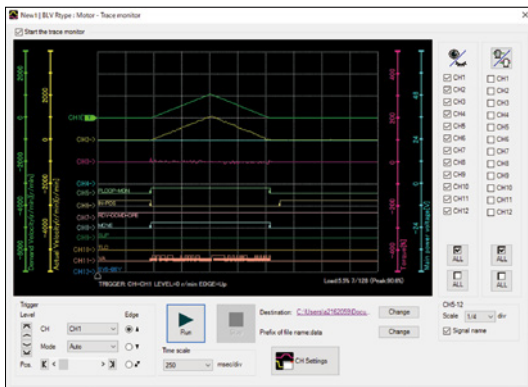

FFT Monitoring

Visualizes mechanical resonance by analyzing frequency using FFT analysis. Noise and vibration can be reduced by adjusting the resonance suppression parameter.

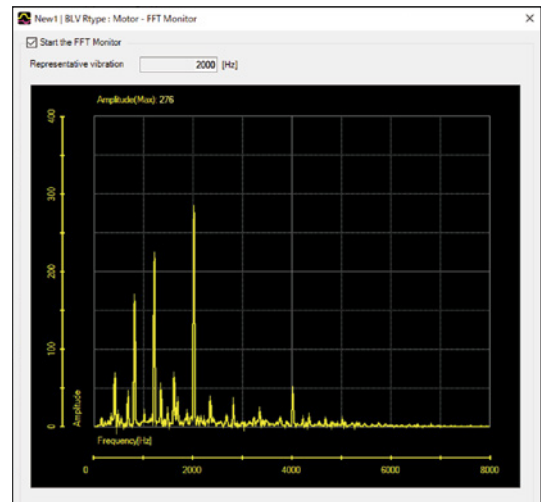

Gain Tuning

Motor tracking can be adjusted according to the command.

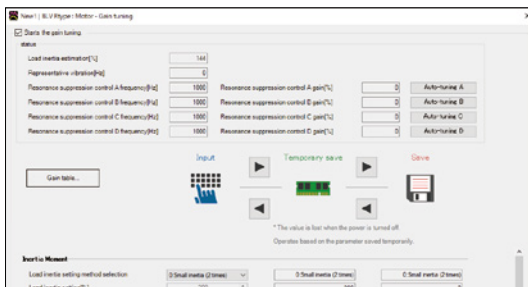

● **Trace Monitoring**

The operating status of the motor can be continuously measured for 24 hours or longer. Data can be saved in CSV format.

Advantages

Data is saved for a long period of time, making it easy to determine the cause of any issues.



Various Monitoring Functions

The **BLST01** Support Software can also monitor various other types of information. For details, please see the Oriental Motor website.

Product Line

Different motors and gearheads are available to suit a wide range of system requirements.

● Motors

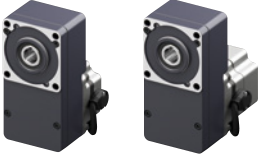
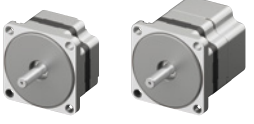
Output Shaft Type	Output Power [W]	Frame Size [mm]	Gear Ratio
Parallel Shaft Gearhead  With Electromagnetic Brake	100	90	10~100
	200	110	
Hollow Shaft Flat Gearhead  With Electromagnetic Brake	100	90	10~200
	200	104	10~100
Round Shaft Type  With Electromagnetic Brake	100	90	-
	200	90	

● Two motor cable outlet directions to choose from



Cable in shaft direction



Cable opposite to shaft direction

● Driver

	Power Supply Voltage [VDC]	Output Power [W]
	24~48	100
		200

● Connection Cables

	Length [m]
	1, 2, 3

● Power Supply Cable

	Length [m]
	0.6

Higher Torque and Space Saving are Achieved with a Hollow Shaft Flat Gearhead

● Permissible Torque with no Saturation

No saturation of permissible torque even at high gear ratios. This is useful for maximizing the motor torque.

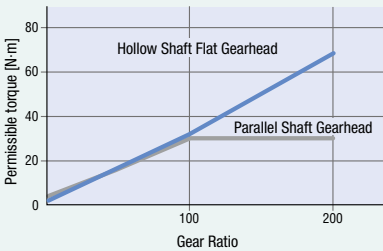

*90 mm frame size

● Space Saving and Cost Reduction

Direct connection to the drive shaft is possible the use of connection components, which facilitates equipment space saving. The elimination of couplings, belts, pulleys, etc. also contributes to a decrease in the cost of parts and assembly work.

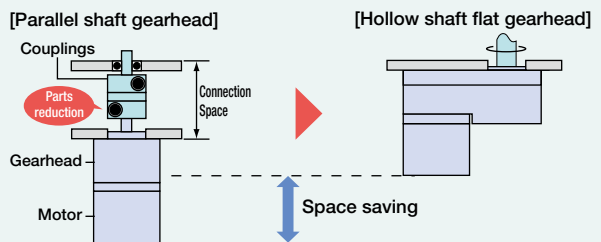

Example: Application in vehicle drive components
Staggered for a compact configuration.

*Only compatible with 200 W

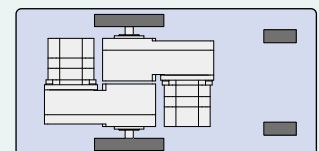

System Configuration

Motors, driver, connection cables, and power supply cables must be ordered separately.

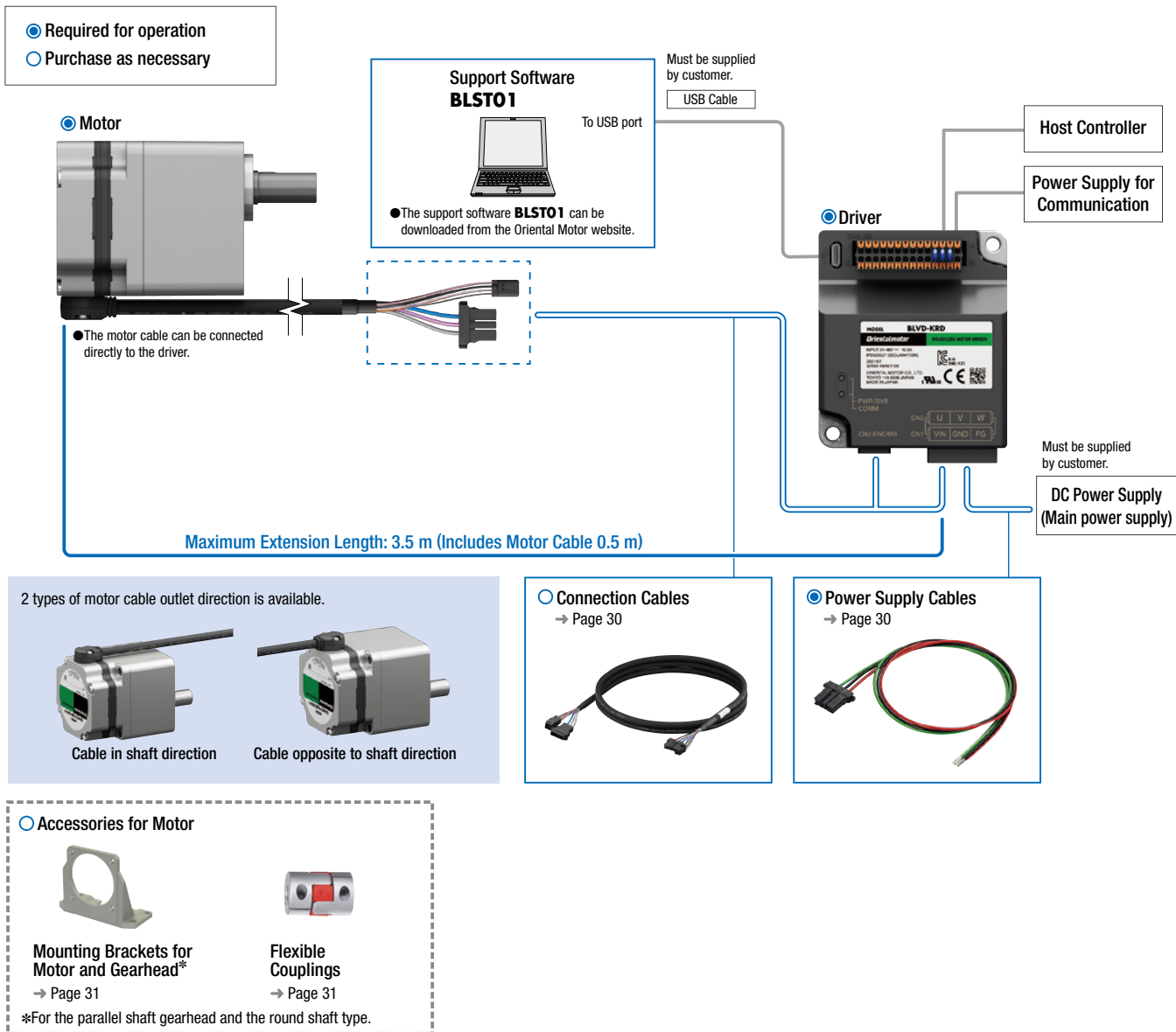

Note

The driver does not include a power supply connector. Please purchase an optional cable or supply a connector separately. For the connector part number, check the dimensions of the power supply cable. → Page 28

Example of System Configuration Pricing

Motor	+	Driver	+	Cables	
BLMR5100K-10-F		BLVD-KRD		Connection Cable (1 m)	Power Supply Cable
334.00 €		345.00 €		CCM010B1AAF	LC03D06A
<input checked="" type="radio"/>		<input checked="" type="radio"/>		40.00 €	14.00 €
				<input type="radio"/>	<input checked="" type="radio"/>

● The system configuration shown above is an example. Other combinations are also available.

Product Number

Motors

BLMR 6 200 S K M - 10 FR - F

① ② ③ ④ ⑤ ⑥ ⑦ ⑧ ⑨

①	Motor Type	BLMR: BLV Series R Type Motor
②	Frame Size	5: 90 mm 6: 104 mm (Gearhead part is 110 mm)
③	Output Power	100: 100 W 200: 200 W
④	Motor Classification	S
⑤	Power Supply Voltage	K: DC Input
⑥		M: Electromagnetic Brake Type
⑦	Gear Ratio and Shaft Type	Number: Gear Ratio for Gearhead A: Round Shaft Type
⑧	Gearhead Type	Blank: Parallel Shaft Gearhead FR: Hollow Shaft Flat Gearhead
⑨	Direction of Cable Outlet	F: Output shaft side B: Opposite side of output shaft

Driver

BLVD - K R D

① ② ③ ④

①	Driver Type	BLVD: BLV Series Driver
②	Power Supply Voltage	K: 24 - 48 VDC
③	Type	R
④	Driver Classification	D

Connection Cables

CCM 010 B1AAF

① ② ③

①	Cable Type	CCM: Connection Cable
②	Length	010: 1 m 020: 2 m 030: 3 m
③	Cable Classification	B1AAF

Product Line

Motors, drivers, connection cables, and power supply cables must be ordered separately.

● Motors

◇ Parallel Shaft Gearhead



Output Power	Product Name	Gear Ratio	List Price
100 W	BLMR5100K -□-■	10, 15, 20	334.00 €
		30, 50, 100	343.00 €
		10, 15, 20	396.00 €
200 W	BLMR6200SK -□-■	30, 50	408.00 €
		100	422.00 €

◇ Hollow Shaft Flat Gearhead

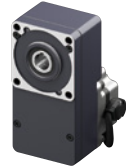

Output Power	Product Name	Gear Ratio	List Price
100 W	BLMR5100K -□ FR -■	10, 15, 20	443.00 €
		30, 50, 100	453.00 €
		200	462.00 €
200 W	BLMR6200SK -□ FR -■	10, 15, 20	513.00 €
		30, 50, 100	523.00 €

◇ Round Shaft Type



Output Power	Product Name	List Price
100 W	BLMR5100K-A -■	223.00 €
200 W	BLMR5200K-A -■	254.00 €

● Driver



Output Power	Product Name	List Price
100 W 200 W	BLVD-KRD	345.00 €

● Electromagnetic Brake Motors

◇ Parallel Shaft Gearhead



Output Power	Product Name	Gear Ratio	List Price
100 W	BLMR5100KM -□-■	10, 15, 20	478.00 €
		30, 50, 100	486.00 €
		10, 15, 20	548.00 €
200 W	BLMR6200SKM -□-■	30, 50	559.00 €
		100	574.00 €

◇ Hollow Shaft Flat Gearhead

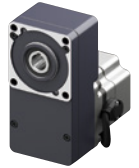

Output Power	Product Name	Gear Ratio	List Price
100 W	BLMR5100KM -□ FR -■	10, 15, 20	587.00 €
		30, 50, 100	597.00 €
		200	606.00 €
200 W	BLMR6200SKM -□ FR -■	10, 15, 20	665.00 €
		30, 50, 100	674.00 €

◇ Round Shaft Type

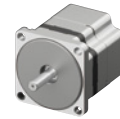

Output Power	Product Name	List Price
100 W	BLMR5100KM-A -■	367.00 €
200 W	BLMR5200KM-A -■	406.00 €

● Connection Cables



Length	Product Name	List Price
1 m	CCM010B1AAF	40.00 €
2 m	CCM020B1AAF	55.00 €
3 m	CCM030B1AAF	69.00 €

● Power Supply Cable



Length	Product Name	List Price
0.6 m	LC03D06A	14.00 €

Included

Type	Parallel Key	Safety Cover	Installation Screw
Parallel Shaft Gearhead	1 Piece	–	1 Set
Hollow Shaft Flat Gearhead	1 Piece	1 Set	1 Set
Round Shaft	–	–	–
Driver	–	–	–

● A number indicating the gear ratio is entered where the box □ is located within the product name.

Either **F** or **B** indicating the cable outlet direction is entered where the box ■ is located within the product name.

List of Combinations

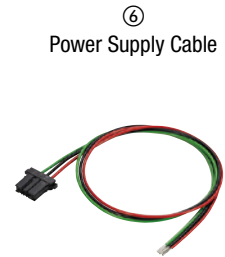
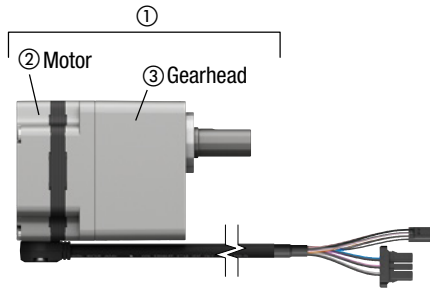

Motors

Output Power	Type	Brushless DC Motor			Driver	Connection Cable	Power Supply Cable
		Product Name	Component Product Name		Product Name	Product Name	Product Name
		①	②	③	④	⑤	⑥
100 W	Parallel Shaft Gearhead	BLMR5100K-□-□	BLMR5100K-GFV-□	GFV5G□	BLVD-KRD	CCM010B1AAF CCM020B1AAF CCM030B1AAF	LC03D06A
	Hollow Shaft Flat Gearhead	BLMR5100K-□FR-□		GFS5G□FR			
	Round Shaft	BLMR5100K-A-□	-	-			
200 W	Parallel Shaft Gearhead	BLMR6200SK-□-□	BLMR6200SK-GFV-□	GFV6G□			
	Hollow Shaft Flat Gearhead	BLMR6200SK-□FR-□		GFS6G□FR			
	Round Shaft	BLMR5200K-A-□	-	-			

Electromagnetic Brake Motors

Output Power	Type	Brushless DC Motor			Driver	Connection Cable	Power Supply Cable
		Product Name	Component Product Name		Product Name	Product Name	Product Name
		①	②	③	④	⑤	⑥
100 W	Parallel Shaft Gearhead	BLMR5100KM-□-□	BLMR5100KM-GFV-□	GFV5G□	BLVD-KRD	CCM010B1AAF CCM020B1AAF CCM030B1AAF	LC03D06A
	Hollow Shaft Flat Gearhead	BLMR5100KM-□FR-□		GFS5G□FR			
	Round Shaft	BLMR5100KM-A-□	-	-			
200 W	Parallel Shaft Gearhead	BLMR6200SKM-□-□	BLMR6200SKM-GFV-□	GFV6G□			
	Hollow Shaft Flat Gearhead	BLMR6200SKM-□FR-□		GFS6G□FR			
	Round Shaft	BLMR5200KM-A-□	-	-			

● A number indicating the gear ratio is entered where the box □ is located within the product name.
 Either **F** or **B** indicating the cable outlet direction is entered where the box ■ is located within the product name.

Parallel Shaft Gearhead 100 W, 200 W



Specifications



Product Name	Motor	With Electromagnetic Brake	BLMR5 100K-□-□		BLMR6200SK-□-□	
			BLMR5 100KM-□-□		BLMR6200SKM-□-□	
	Driver		BLVD-KRD			
Rated Output Power (Continuous)	W		100		200	
Rated Voltage	V		24 - 48 VDC			
Power Supply	Permissible Voltage Range	V	15 - 55 VDC			
Input	Rated Input Current	A	2.6 (48 VDC) to 5.1 (24 VDC)		5.3 (48 VDC) to 10.5 (24 VDC)	
	Maximum Input Current	A	10		18	
Rated Speed	r/min		3000			
Speed Control Range*			1 to 4000 r/min (Speed ratio 4000:1)			
Speed Regulation	Load		Max. ±0.01% Conditions: 0 to rated torque, at rated speed, at rated voltage, at normal temperature			
	Voltage		Max. ±0.01% Conditions: Rated voltage 24 - 48 VDC, at rated speed, with no load, at normal temperature			
	Temperature		Max. ±0.01% Conditions: Operating ambient temperature 0 to +40°C, at rated speed, with no load, at rated voltage			
Resolution*			0.01° (36000 Pulses per rotation)			
Electromagnetic Brake	Type		Power off activated type, automatically controlled by the driver			
	Static Friction Torque	N·m	0.319		0.637	

*Factory setting

● The values in the table are characteristics for the motor only.

Gear Ratio		10	15	20	30	50	100	
Rotation Direction	100 W	Same direction as the motor			Opposite direction to the motor			
	200 W	Same direction as the motor			Opposite direction to the motor		Same direction as the motor	
Output Shaft Speed [r/min]*1	1 r/min	0.1	0.067	0.05	0.033	0.02	0.01	
	3000 r/min	300	200	150	100	60	30	
	4000 r/min	400	267	200	133	80	40	
Permissible Torque [N·m]	100 W	At 1 to 3000 r/min	2.9	4.3	5.7	8.2	13.7	27.4
		At 4000 r/min	2.2	3.2	4.3	6.2	10.3	20.6
	200 W	At 1 to 3000 r/min	5.7	8.6	11.5	16.4	27.4	51.6
		At 4000 r/min	4.1	6.1	8.1	11.6	19.4	36.5
Maximum Instantaneous Torque [N·m]	100 W	5.7	8.6	11.5	16.5	27.4	40	
	200 W	11.5	17.2	22.9	32.9	55	100	
Permissible Inertia J [$\times 10^{-4}$ kg·m ²]	When acceleration/deceleration time is set*2	100 W	2300	5175	9200	20700	57500	230000
		200 W	3400	7650	13600	30600	85000	340000
	Instantaneous stop*3	100 W	100	225	400	900	2500	2500
		200 W	200	450	800	1800	5000	5000
Permissible Radial Load [N]	10 mm from the end of the output shaft	100 W	At 1 to 3000 r/min		400			500
			At 4000 r/min		370			450
		200 W	At 1 to 3000 r/min		550			1000
		At 4000 r/min		500			900	
	20 mm from the end of the output shaft	100 W	At 1 to 3000 r/min		500			650
			At 4000 r/min		430			550
200 W		At 1 to 3000 r/min		800			1250	
	At 4000 r/min		700			1100		
Permissible Axial Load [N]	100 W				150			
	200 W	200		300		400		

*1 The output shaft speed is calculated by dividing the speed by the gear ratio.

*2 This is the maximum permissible inertia when the acceleration/deceleration time is set to 0.1 seconds or longer.

Set the acceleration/deceleration time so that the torque required for acceleration/deceleration operation does not exceed the maximum instantaneous torque.

*3 Also applies when the deceleration time is set to less than 0.1 seconds.

◇ Load Position

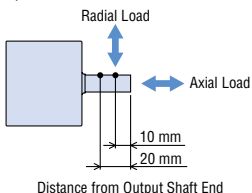

Speed – Torque Characteristics

→ Page 18

Dimensions

Motors → Page 20

Electromagnetic Brake Motors → Page 24

Driver → Page 28

● A number indicating the gear ratio is entered where the box □ is located within the product name.

Either **F** or **B** indicating the cable outlet direction is entered where the box ■ is located within the product name.

Hollow Shaft Flat Gearhead 100 W, 200 W

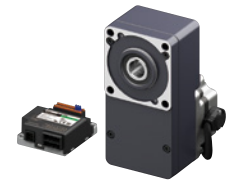

Specifications



Product Name	Motor	With Electromagnetic Brake	BLMR5100K-□FR-□		BLMR6200SK-□FR-□	
			BLMR5100KM-□FR-□		BLMR6200SKM-□FR-□	
Driver			BLVD-KRD			
Rated Output Power (Continuous)	W		100		200	
Rated Voltage	V		24 - 48 VDC			
Power Supply	Permissible Voltage Range	V	15 - 55 VDC			
Input	Rated Input Current	A	2.6 (48 VDC) to 5.1 (24 VDC)		5.3 (48 VDC) to 10.5 (24 VDC)	
	Maximum Input Current	A	10		18	
Rated Speed	r/min		3000			
Speed Control Range*			1 to 4000 r/min (Speed ratio 4000:1)			
Speed Regulation	Load		Max. ±0.01% Conditions: 0 to rated torque, at rated speed, at rated voltage, at normal temperature			
	Voltage		Max. ±0.01% Conditions: Rated voltage 24 - 48 VDC, at rated speed, with no load, at normal temperature			
	Temperature		Max. ±0.01% Conditions: Operating ambient temperature 0 to +40°C, at rated speed, with no load, at rated voltage			
Resolution*			0.01° (36000 Pulses per rotation)			
Electromagnetic Brake	Type		Power off activated type, automatically controlled by the driver			
	Static Friction Torque	N·m	0.319		0.637	

*Factory setting

● The values in the table are characteristics for the motor only.

Gear Ratio		10	15	20	30	50	100	200*1	
Output Shaft Speed [r/min]*2	1 r/min	0.1	0.067	0.05	0.033	0.02	0.01	0.005	
	3000 r/min	300	200	150	100	60	30	15	
	4000 r/min	400	267	200	133	80	40	20	
Permissible Torque [N·m]	100 W	At 1 to 3000 r/min	2.7	4.1	5.4	8.1	13.6	27.1	54
		At 4000 r/min	2.0	3.0	4.1	6.1	10.2	20.3	40.6
	200 W	At 1 to 3000 r/min	5.4	8.1	10.8	16.2	27	54	—
		At 4000 r/min	3.8	5.7	7.7	11.5	19.1	38.3	—
Maximum Instantaneous Torque [N·m]	100 W	5.4	8.1	10.8	16.3	27.1	54	85	
	200 W	10.8	16.2	21.7	32.5	54	108	—	
Permissible Inertia J [$\times 10^{-4}$ kg·m ²]	When acceleration/deceleration time is set*3	100 W	2300	5175	9200	20700	57500	230000	920000
		200 W	3400	7650	13600	30600	85000	340000	—
	Instantaneous stop*4	100 W	100	225	400	900	2500		
		200 W	200	450	800	1800	5000		
Permissible Radial Load [N]*5	10 mm from installation surface	100 W	At 1 to 3000 r/min		900	1300		1500	
			At 4000 r/min		820	1200		1400	
		200 W	At 1 to 3000 r/min		1230	1680		2040	
		At 4000 r/min		1130	1550		1900		
	20 mm from installation surface	100 W	At 1 to 3000 r/min		770	1110		1280	
			At 4000 r/min		700	1020		1200	
200 W		At 1 to 3000 r/min		1070	1470		1780		
	At 4000 r/min		990	1360		1660			
Permissible Axial Load [N]	100 W	500						—	
	200 W	800						—	

*1 Gear ratio **200** is only for the output power of 100 W.

*2 The output shaft speed is calculated by dividing the speed by the gear ratio.

*3 This is the maximum permissible inertia when the acceleration/deceleration time is set to 0.1 seconds or longer.

Set the acceleration/deceleration time so that the torque required for acceleration/deceleration operation does not exceed the maximum instantaneous torque.

*4 Also applies when the deceleration time is set to less than 0.1 seconds.

*5 The radial load at each distance can be calculated with a formula. → Page 29

◇ Rotation Direction

● Front View

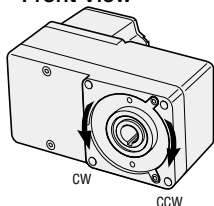

● Rear View

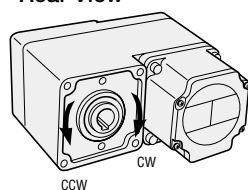

◇ Load Position

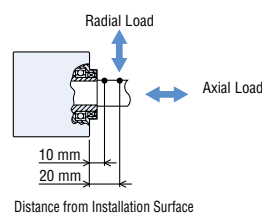

Speed – Torque Characteristics

→ Page 18

Dimensions

Motors → Page 21, 22

Electromagnetic Brake Motors → Page 25, 26

Driver → Page 29

● A number indicating the gear ratio is entered where the box □ is located within the product name.

Either **F** or **B** indicating the cable outlet direction is entered where the box ■ is located within the product name.

Round Shaft 100 W, 200 W



Specifications



Product Name	Motor	With Electromagnetic Brake	BLMR5100K-A-□	BLMR5200K-A-□
			BLMR5100KM-A-□	BLMR5200KM-A-□
	Driver		BLVD-KRD	
Rated Output Power (Continuous)	W		100	200
Power Supply Input	Rated Voltage	V	24 - 48 VDC	
	Permissible Voltage Range	V	15 - 55 VDC	
	Rated Input Current	A	2.6 (48 VDC) to 5.1 (24 VDC)	5.3 (48 VDC) to 10.5 (24 VDC)
	Maximum Input Current	A	10	18
Rated Speed	r/min		3000	
Speed Control Range*1			1 to 4000 r/min (Speed ratio 4000:1)	
Rated Torque	N·m		0.319	0.637
Maximum Instantaneous Torque	N·m		0.704 (220%)	1.34 (210%)
Rotor Inertia J	$\times 10^{-4} \text{kg}\cdot\text{m}^2$		0.23 (0.25)*2	0.454 (0.47)*2
Permissible Inertia	$\times 10^{-4} \text{kg}\cdot\text{m}^2$		23	34
Permissible Radial Load	10 mm from the end of the output shaft	N	150	
	20 mm from the end of the output shaft	N	170	
Permissible Axial Load	N		25	
Speed Regulation	Load		Max. $\pm 0.01\%$ Conditions: 0 to rated torque, at rated speed, at rated voltage, at normal temperature	
	Voltage		Max. $\pm 0.01\%$ Conditions: Rated voltage 24 - 48 VDC, at rated speed, with no load, at normal temperature	
	Temperature		Max. $\pm 0.01\%$ Conditions: Operating ambient temperature 0 to +40°C, at rated speed, with no load, at rated voltage	
Resolution*1			0.01° (36000 Pulses per rotation)	
Electromagnetic Brake	Type		Power off activated type, automatically controlled by the driver	
	Static Friction Torque	N·m	0.319	0.637

*1 Factory setting

*2 The values in the parentheses () represent the values for the electromagnetic brake type.

◇ Load Position

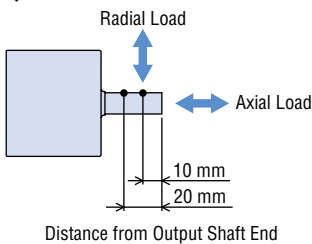

Speed – Torque Characteristics

Continuous Duty Region: Continuous operation is possible in this region.

Limited Duty Region: This region is primarily used when accelerating.

● 100 W

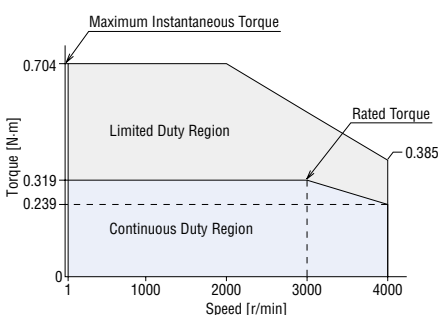

● 200 W

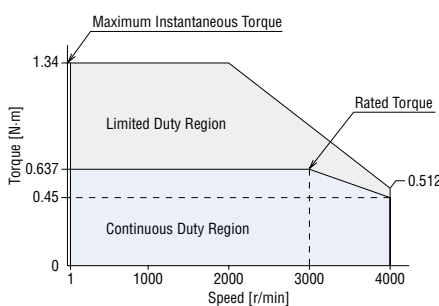

● The values correspond to each specification and characteristic of the motor only. The speed - torque characteristics indicate the values when rated voltage is applied.

Dimensions

Motors → Page 23

Electromagnetic Brake Motors → Page 27

Driver → Page 28

● Either **F** or **B** indicating the cable outlet direction is entered where the box □ is located within the product name.

Common Specifications

Items	Specifications
Input Signals	4 Inputs, Photocoupler Input Method
Output Signals	2 Outputs, Photocoupler and Open-Collector Output
Main Operation Functions	Continuous Operation, Positioning Operation, JOG Operation, Return-to-Home Operation
Operating Data Setting Number	256 Points
Setting Tool	BLST01 Support Software
Maximum Extension Length	Motor and Driver Distance: 3.5 m (when a separately sold connection cable is used)
Time Rating	Continuous

Communication Specifications

RS-485 Communication Specifications

Electrical Characteristics	EIA-485 Based Use a shielded twisted pair cable and keep the total wiring distance including extension to 10 m or less.*
Communication Mode	Half duplex and start-stop synchronization (data: 8 bits, stop bit: 1 bit or 2 bits, parity: none, even, or odd)
Transmission Rate	Select either from 9600 bps, 19200 bps, 38400 bps, 57600 bps, 115200 bps, or 230400 bps (initial value).
Protocol	Modbus RTU Mode
Connection Type	Up to 31 units can be connected to a single programmable controller.

*If a specific wiring and layout causes the motor cable or power supply cable to generate a noise problem, shield the cable or use ferrite cores.

CANopen Communication Specifications

Electrical Characteristics	In conformance with ISO 11898 Use the CAN-Bus cable.
Communication Protocol	CANopen
Communication Profile	In conformance with CiA DS301 Version 4.2.0
Device Profile	In conformance with CiA DSP402 Version 4.0.0
Node ID	1 to 127
Bit Rate	Selectable from 1 Mbps, 800 kbps, 500 kbps (initial value), 250 kbps, 125 kbps, 50 kbps, 20 kbps, 10 kbps
Maximum Bus Length	25 m (Maximum bus length at 1 Mbps)
Communication Objects	NMT (Network Management) SDO (Service Data Object: 1 SDO server) PDO (Process Data Object: 4 Receive-PDO, 4 Transmit-PDO) EMCY (Emergency Object) SYNC (Synchronization Object)
Operation Modes	Profile Velocity Mode (pv) Profile Position Mode (pp) Homing Mode (hm)

General Specifications

Item	Motor	Driver
Insulation Resistance	100 MΩ or more when a 500 VDC megger is applied between the windings and the case after continuous operation under normal ambient temperature and humidity.	100 MΩ or more when a 500 VDC megger is applied between the heat sink and the main power supply input after continuous operation under normal ambient temperature and humidity.
Dielectric Strength	Sufficient to withstand 0.5 kVAC at 50 Hz applied between the windings and the case for 1 minute after continuous operation under normal ambient temperature and humidity.	Sufficient to withstand 0.5 kVAC at 50 Hz applied between the heat sink and the power supply input for 1 minute after continuous operation under normal ambient temperature and humidity.
Temperature Rise	The temperature rise of the windings is 60°C max. and that of the case surface is 50°C max.*1, measured by the thermocouple method after rated continuous operation under normal ambient temperature and humidity.	The temperature rise of the heat sink is 50°C max., measured by the thermocouple method after rated continuous operation under normal ambient temperature and humidity.
Operating Environment	Ambient Temperature	0 ~ +40°C (Non-freezing)
	Ambient Humidity	85% or less (Non-condensing)
	Altitude	Up to 1000 m above sea level
	Atmosphere	No corrosive gases or dust. The product should not be exposed to oil. Cannot be used in a radioactive area, magnetic field, vacuum, or other special environments.
Storage Condition*3	Ambient Temperature	-20 to +70°C (Non-freezing)
	Ambient Humidity	85% or less (Non-condensing)
	Altitude	Up to 3000 m above sea level
	Atmosphere	No corrosive gases or dust. The product should not be exposed to water, oil. Cannot be used in a radioactive area, magnetic field, vacuum, or other special environments.
Thermal Class	UL/CSA Standards: 105 (A), EN Standards: 120 (E)	—
Degree of Protection	IP40	IP20

*1 For round shaft type motor, attach to a heat sink (Material: aluminum) of one of the following sizes to maintain a motor case surface temperature of 90°C or less.

100 W type: 165×165 mm thickness 5 mm, 200 W type: 200×200 mm thickness 5 mm

*2 Install the driver to a location that has the same heat radiation capability as an aluminum metal plate.

200×200 mm thickness 2 mm

*3 The storage condition applies to short periods such as the period during transport.

Note

● Do not measure the insulation resistance or perform a dielectric voltage withstand test while the motor and driver are connected.

Dimensions (Unit: mm)

- Installation screws are included with the parallel shaft gearhead and the hollow shaft flat gearhead.
Included → Page 14, Dimensions for Installation Screws → Page 29
- A number indicating the gear ratio is entered where the box □ is located within the product name.
Either **F** (output shaft side) or **B** (opposite to output shaft side) indicating the cable outlet direction is entered where the box ■ is located within the product name.

● Motors

◇ Parallel Shaft Gearhead 100 W

Product Name	Motor Product Name	Gearhead Product Name	Gear Ratio	L	Mass [kg]
BLMR5100K -□-■	BLMR5100K-GFV-■	GFV5G□	10 to 20	45	2.05
			30 to 100	58	2.4

● Cable Outlet in Output Shaft Direction

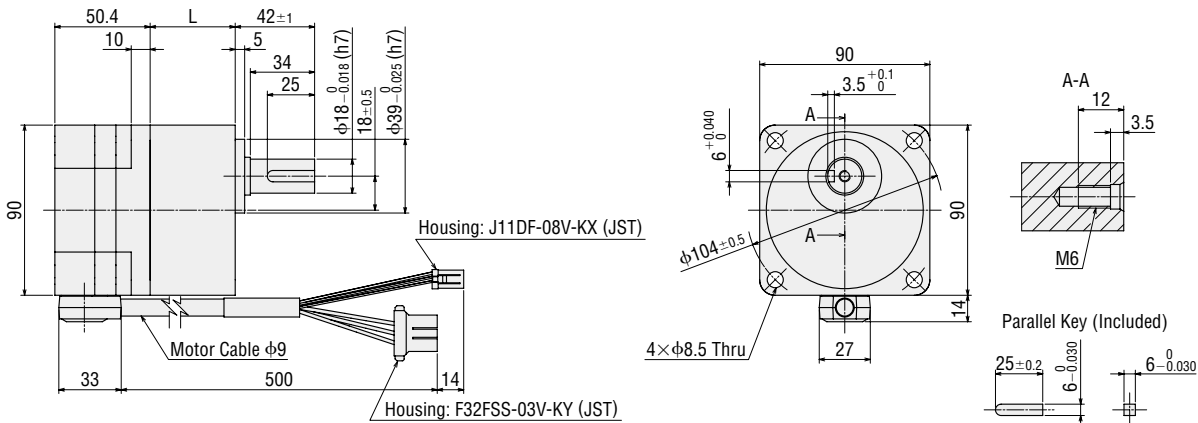

● Cable Outlet Opposite to Output Shaft Direction

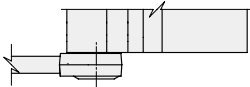

◇ Parallel Shaft Gearhead 200 W

Product Name	Motor Product Name	Gearhead Product Name	Gear Ratio	L	Mass [kg]
BLMR6200SK -□-■	BLMR6200SK-GFV-■	GFV6G□	10 to 20	60	3.6
			30, 50	72	4.1
			100	86	4.7

● Cable Outlet in Output Shaft Direction

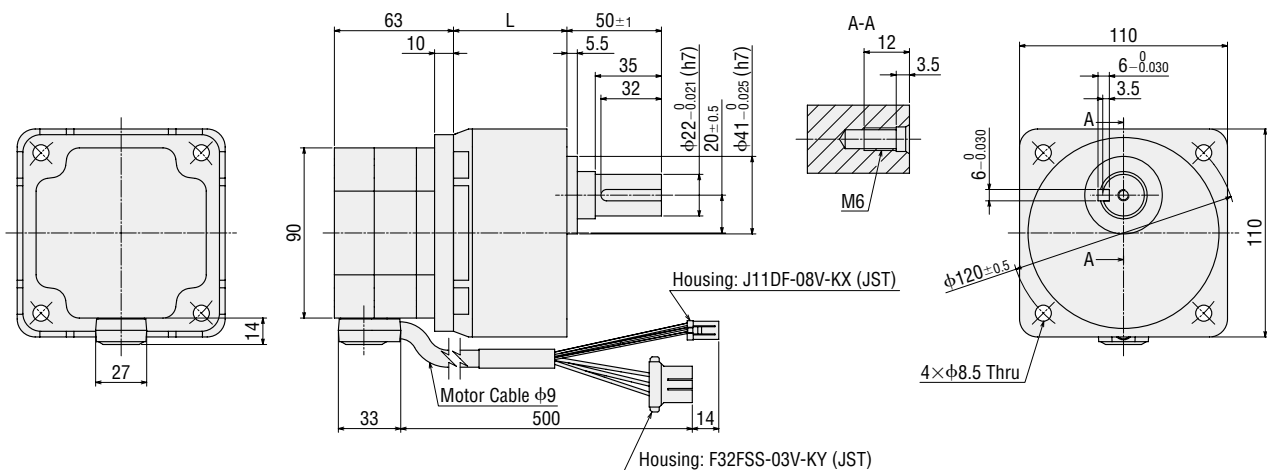

● Cable Outlet Opposite to Output Shaft Direction

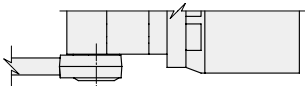

◇Hollow Shaft Flat Gearhead 100 W

Product Name	Motor Product Name	Gearhead Product Name	Gear Ratio	Mass [kg]
BLMR5100K-□FR-■	BLMR5100K-GFV-■	GFS5G□FR	10 to 200	3.3

●Cable Outlet in Output Shaft Direction

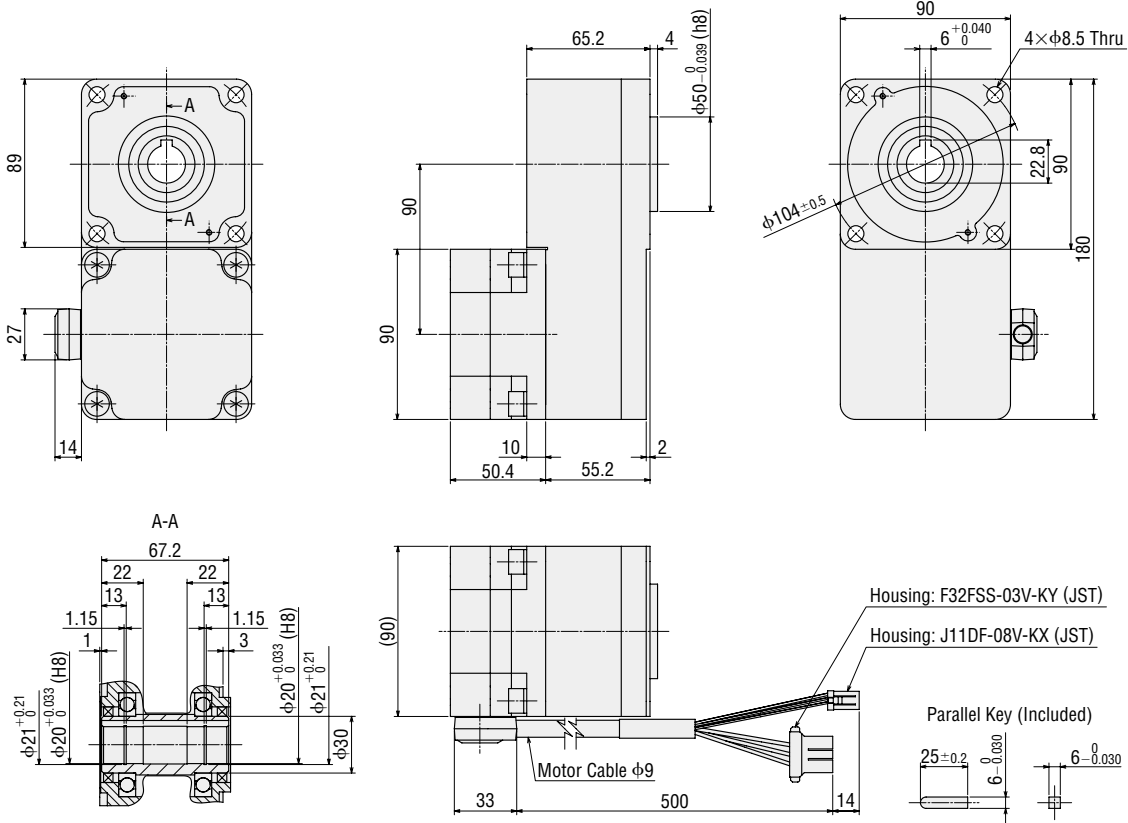

●Cable Outlet Opposite to Output Shaft Direction

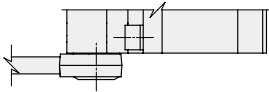

◇Hollow Shaft Flat Gearhead 200 W

Product Name	Motor Product Name	Gearhead Product Name	Gear Ratio	Mass [kg]
BLMR6200SK-□FR-■	BLMR6200SK-GFV-■	GFS6G□FR	10 to 100	6.5

●Cable Outlet in Output Shaft Direction

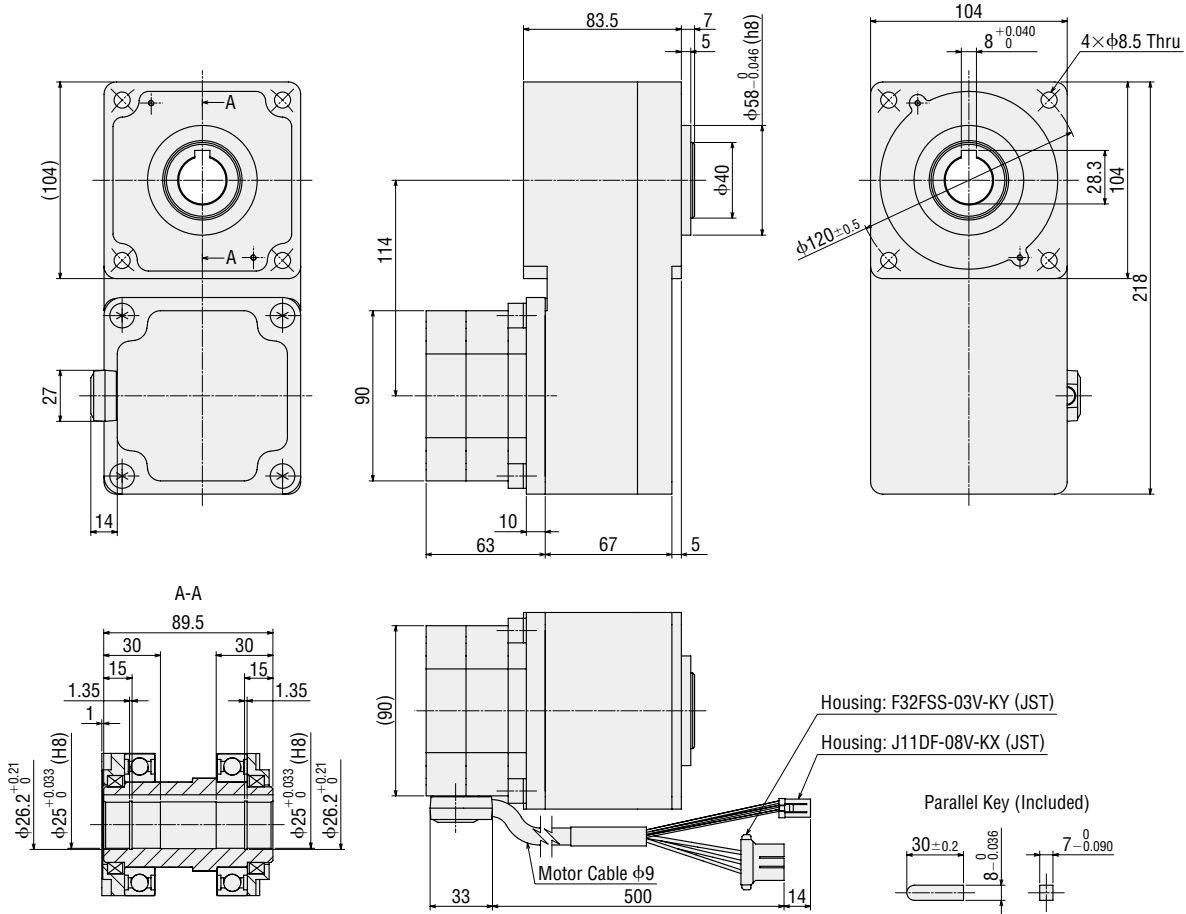

●Cable Outlet Opposite to Output Shaft Direction

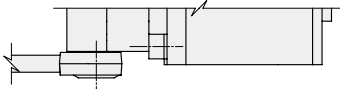

◇ Round Shaft Type 100 W

BLMR5100K-A ■

Mass: 1.1 kg

● Cable Outlet in Output Shaft Direction

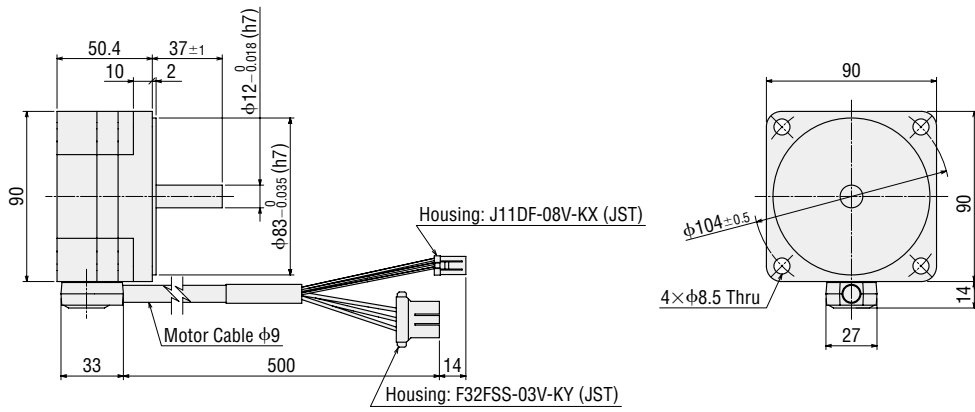

● Cable Outlet Opposite to Output Shaft Direction

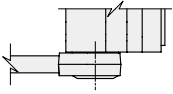

◇ Round Shaft Type 200 W

BLMR5200K-A ■

Mass: 1.6 kg

● Cable Outlet in Output Shaft Direction

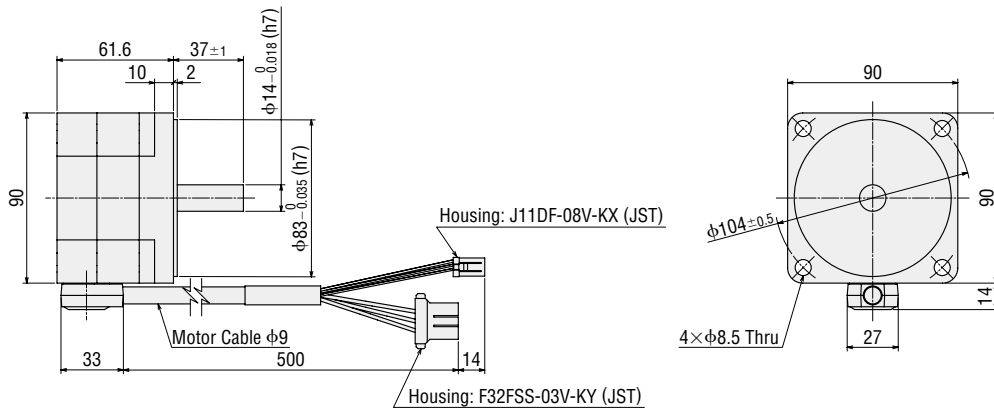

● Cable Outlet Opposite to Output Shaft Direction

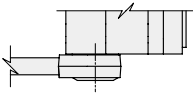

● Electromagnetic Brake Motors

◇ Parallel Shaft Gearhead 100 W

Product Name	Motor Product Name	Gearhead Product Name	Gear Ratio	L	Mass [kg]
BLMR5100KM -□-□	BLMR5100KM-GFV-□	GFV5G□	10 to 20	45	2.65
			30 to 100	58	3.0

● Cable Outlet in Output Shaft Direction

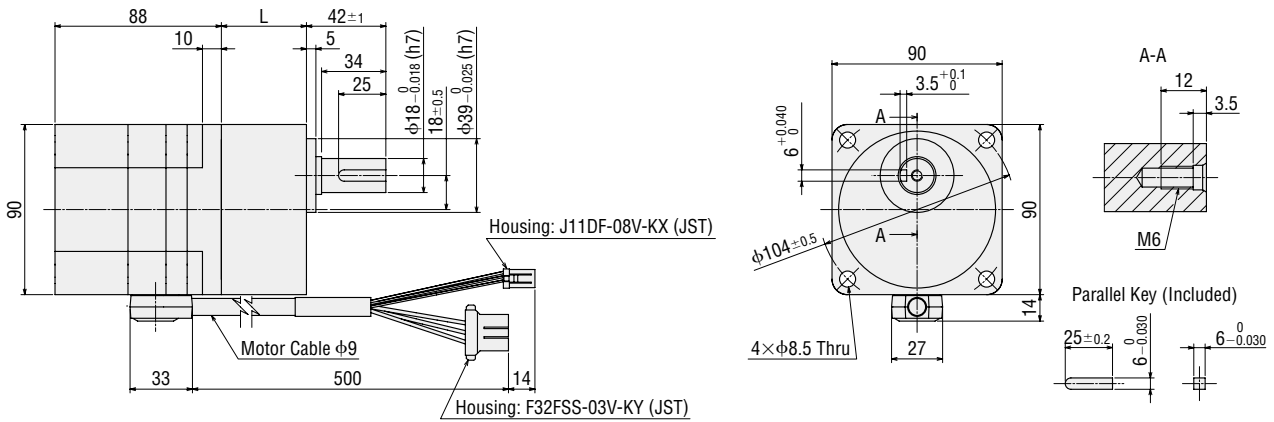

● Cable Outlet Opposite to Output Shaft Direction

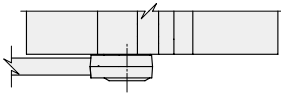

◇ Parallel Shaft Gearhead 200 W

Product Name	Motor Product Name	Gearhead Product Name	Gear Ratio	L	Mass [kg]
BLMR6200SKM -□-□	BLMR6200SKM-GFV-□	GFV6G□	10~20	60	4.1
			30, 50	72	4.6
			100	86	5.2

● Cable Outlet in Output Shaft Direction

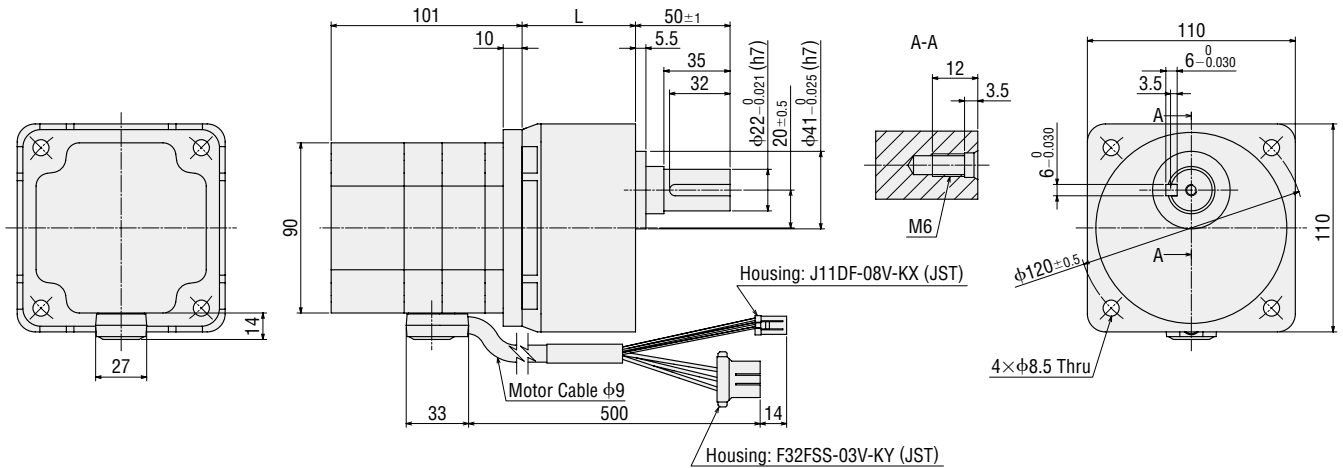

● Cable Outlet Opposite to Output Shaft Direction

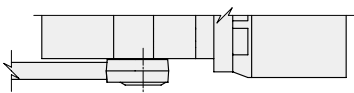

◇Hollow Shaft Flat Gearhead 100 W

Product Name	Motor Product Name	Gearhead Product Name	Gear Ratio	Mass [kg]
BLMR5100KM-□FR-□	BLMR5100KM-GFV-□	GFS5G□FR	10 to 200	3.9

●Cable Outlet in Output Shaft Direction

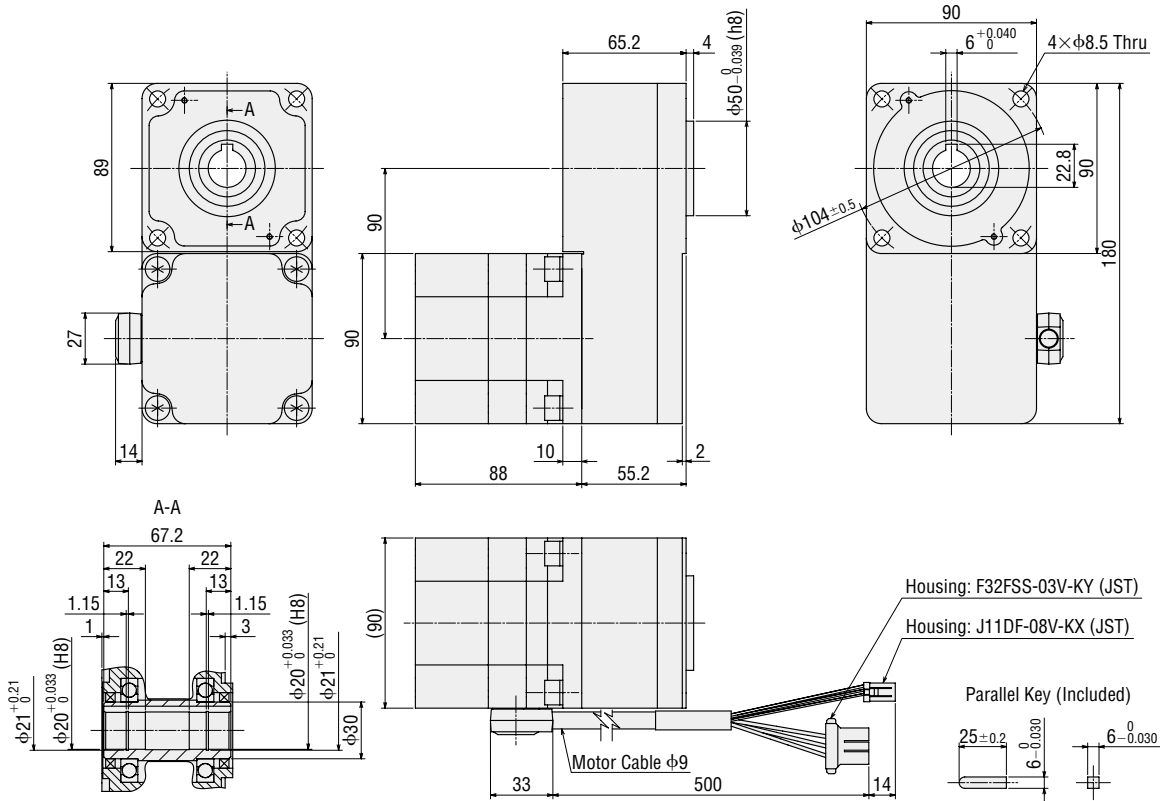

●Cable Outlet Opposite to Output Shaft Direction

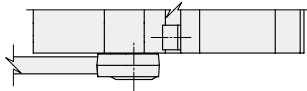

◇Hollow Shaft Flat Gearhead 200 W

Product Name	Motor Product Name	Gearhead Product Name	Gear Ratio	Mass [kg]
BLMR6200SKM-□FR-■	BLMR6200SKM-GFV-■	GFS6G□FR	10 to 100	7.0

●Cable Outlet in Output Shaft Direction

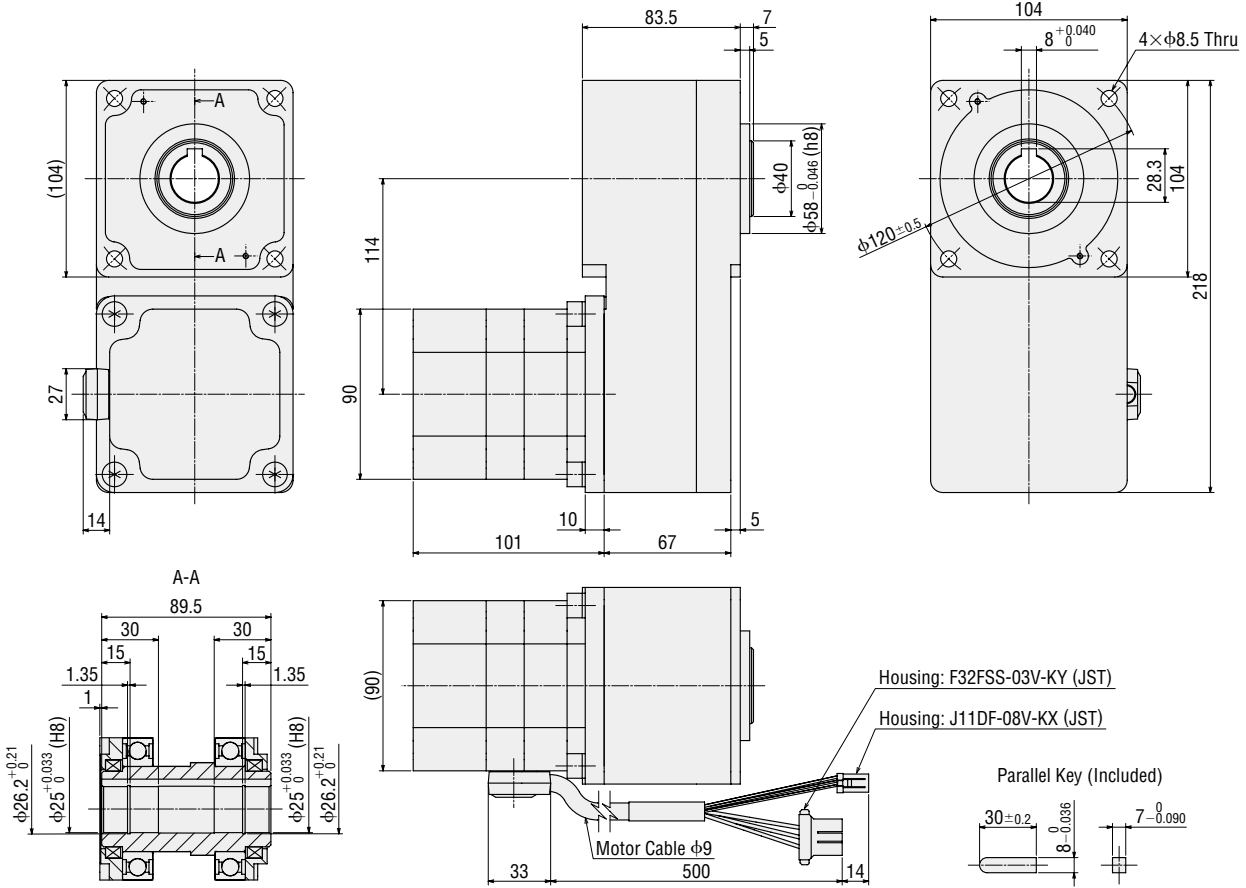

●Cable Outlet Opposite to Output Shaft Direction

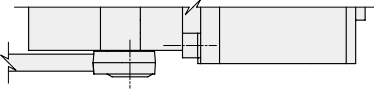

◇ Round Shaft Type 100 W

BLMR5100KM-A ■

Mass: 1.7 kg

● Cable Outlet in Output Shaft Direction

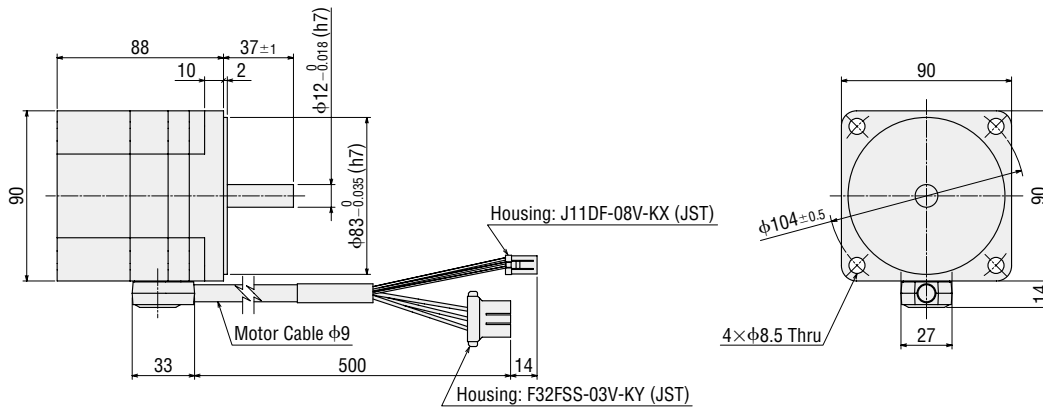

● Cable Outlet Opposite to Output Shaft Direction

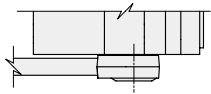

◇ Round Shaft Type 200 W

BLMR5200KM-A ■

Mass: 2.1 kg

● Cable Outlet in Output Shaft Direction

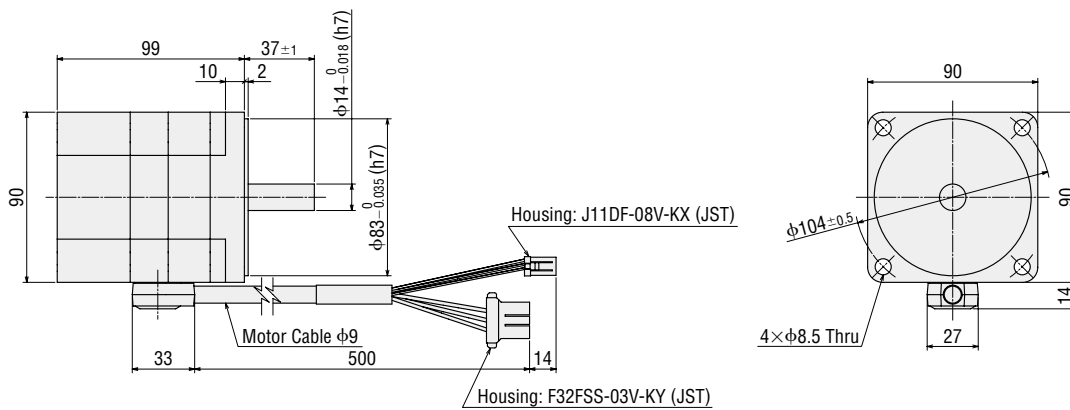

● Cable Outlet Opposite to Output Shaft Direction

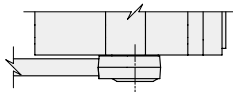

● Driver

BLVD-KRD

Mass: 0.12 kg

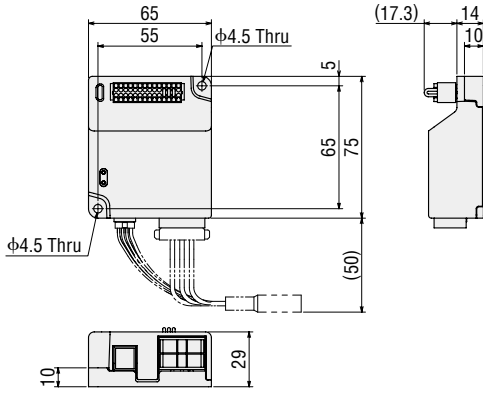

● Connection Cables

Length L (m)	Product Name
1	CCM010B1AAF
2	CCM020B1AAF
3	CCM030B1AAF

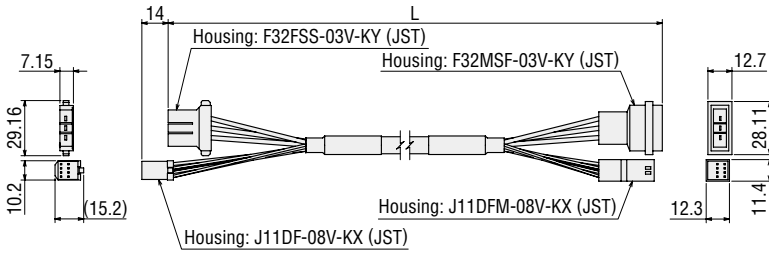

● Power Supply Cable

LC03D06A

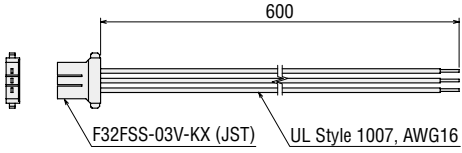

■ Dimensions for Installation Screws

L2 is the dimension when a plain washer and a spring washer are attached to the head side of the screw.

● Parallel Shaft Gearhead

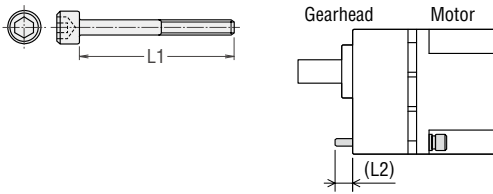

Product Name	Gear Ratio	Installation Screw		L2 (mm)
		Screw Size	L1 (mm)	
GFV5G□	10 to 20	M8	70	11.5
	30 to 100		85	
GFV6G□	10 to 20	M8	85	11
	30, 50		100	14
	100		110	10

- Installation Screws: 4 flat washers and 4 spring washers are included.
The installation screw material is stainless steel.

● Hollow Shaft Flat Gearhead

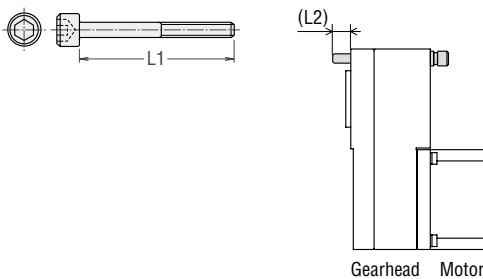

Product Name	Gear Ratio	Installation Screw		L2 (mm)
		Screw Size	L1 (mm)	
GF55G□FR	10 to 200	M8	90	21
GF66G□FR	10 to 100	M8	100	13

- Installation screws: 4 pieces each of flat washers, spring washers, and hexagonal nuts are included.
For GF66G□FR, hexagonal nuts are not included.
- A number indicating the gear ratio is entered where the box □ is located within the product name.

■ Permissible Radial Load Calculation of Hollow Shaft Flat Gearhead

The formula for permissible radial load varies depending on the mechanism.

◇ When end of shaft being driven is not supported by a bearing

This mechanism experiences the highest amount of radial load. The stepped type is recommended for the load shaft.

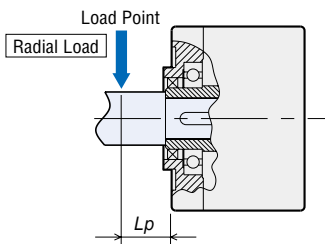

F_0 [N]: Permissible Radial Load at the Flange-Mounting Surface

L_p [mm]: Distance from Flange-Mounting Surface to Radial Load Point

B [mm] Distance from Flange-Mounting Surface to Bearing Unit

Product Name	Permissible Radial Load W [N]
GF55G□FR	$W [N] = \frac{50}{50 + L_p} \times F_0 [N]$
GF66G□FR	$W [N] = \frac{60}{60 + L_p} \times F_0 [N]$

◇ When end of shaft being driven is supported by a bearing

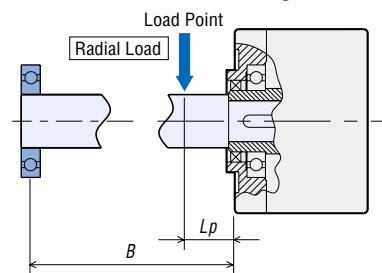

Product Name	Permissible Radial Load W [N]
GF55G□FR GF66G□FR	$W [N] = \frac{B}{B - L_p} \times F_0 [N]$

Product Name	Speed	Gear Ratio	F_0 [N]
GF55G□FR	At 1 to 3000 r/min	10	1080
		15, 20	1550
		30 to 200	1800
	At 4000 r/min	10	980
		15, 20	1430
		30 to 200	1680
GF66G□FR	At 1 to 3000 r/min	10	1430
		15, 20	1960
		30 to 100	2380
	At 4000 r/min	10	1320
		15, 20	1810
		30 to 100	2210

- A number indicating the gear ratio is entered where the box □ is located within the product name.

Cables and Accessories (Sold separately)

Cables

Cable System Configuration

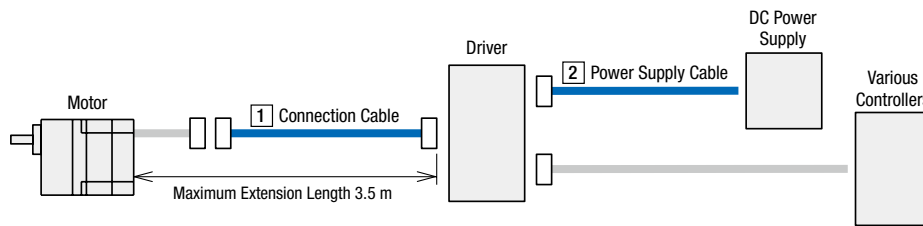

1 Connection Cables

These cables are used to connect the motor and the driver. Keep the overall length of the cable at 3.5 m or less.



● Product Line → Page 14

● Dimensions → Page 28

2 Power Supply Cable

This cable is used to connect the driver and the DC power supply.



● Product Line → Page 14

● Dimensions → Page 28

Motor and Gearhead Mounting Brackets

These dedicated mounting brackets are convenient for mounting and securing parallel shaft gearhead and round shaft type motor.



Product Line

Product Name	List Price	Applicable Products
SOL5M8F	25.00 €	BLMR5100 BLMR5200 (Round Shaft Type)
SOL6M8F	27.00 €	BLMR6200 (Parallel Shaft Gearhead)

Note

- These mounting brackets cannot be used with the hollow shaft flat gearhead.

Flexible Couplings

These products are clamp type couplings to connect a motor or gearhead shaft to the shaft of the equipment.

The couplings that can be used for a motor with parallel shaft gearhead and for the round shaft type motor are available.

- Couplings can also be used with round shaft types.

Select a coupling with the same inner diameter size as the motor shaft diameter.



Product Line

Applicable Product	Load Type	Coupling Type	List Price
BLMR5100	Uniform Load	MCL55 Type	72.00 €
	Impact Load		
BLMR6200	Uniform Load	MCL65 Type	115.00 €
	Impact Load		

Orientalmotor

These products are manufactured at plants certified with the international standards **ISO 9001** (for quality assurance) and **ISO 14001** (for systems of environmental management).

Specifications are subject to change without notice. This catalogue was published in November 2021.

ORIENTAL MOTOR (EUROPA) GmbH

www.orientalmotor.de

European Headquarters

Schießstraße 44
40549 Düsseldorf, Germany
Tel: 0211-520 670 0 Fax: 0211-520 670 99

Spanish Office

C/Caléndula 93 - Ed. E - Miniparc III
28109 El Soto de La Moraleja,
Alcobendas (Madrid), Spain
Tel: +34 918 266 565
www.orientalmotor.es



ORIENTAL MOTOR (UK) LTD.

www.oriental-motor.co.uk

UK Headquarters

Unit 5, Faraday Office Park,
Rankine Road, Basingstoke,
Hampshire RG24 8AH, U.K.
Tel: 01256-347 090 Fax: 01256-347 099



ORIENTAL MOTOR SWITZERLAND AG

www.orientalmotor.ch

Switzerland Headquarters

Badenerstrasse 13
5200 Brugg AG, Switzerland
Tel: 056-560 504 5 Fax: 056-560 504 7



ORIENTAL MOTOR ITALIA s.r.l.

www.orientalmotor.it

Italy Headquarters

Via XXV Aprile 5
20016 Pero (MI), Italy
Tel: 02-939 063 46 Fax: 02-939 063 48



ORIENTAL MOTOR (FRANCE) SARL

www.orientalmotor.fr

France Headquarters

56, Rue des Hautes Pâtures
92000 Nanterre, France
Tel: 01-478 697 50 Fax: 01-478 245 16



Other countries: www.orientalmotor.eu

Customer Service Center (Support in German & English)

00800-22 55 66 22*
CA LL OM CC

Mon-Thu: 08:00 - 16:30 CET Friday: 08:00 - 15:00 CET

*Free Call Europe

info@orientalmotor.de

For more information please contact: