



## Brushless Motor

# BLH Series Analog Setting Type

## OPERATING MANUAL



Thank you for purchasing an Oriental Motor product.  
This Operating Manual describes product handling procedures and safety precautions.

- Please read it thoroughly to ensure safe operation.
- Always keep the manual where it is readily available.

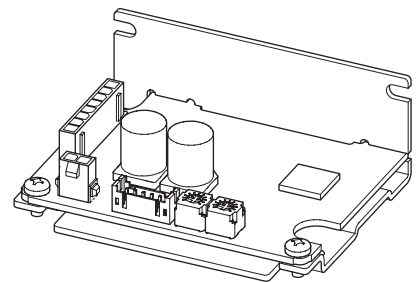

### Table of contents

1	Introduction .....	2	7	Operation .....	17
2	Safety precautions .....	3	7.1	Setting the rotation speed.....	17
3	Precautions for use .....	5	7.2	Setting the acceleration time and deceleration time .....	18
4	Preparation .....	6	7.3	Operation and stop .....	18
4.1	Checking the product.....	6	7.4	Rotation direction of the motor output shaft .....	20
4.2	How to identify the product model.....	6	7.5	Multi-motor control.....	20
4.3	Information about nameplate.....	6	8	Maintenance and inspection .....	21
4.4	Products possible to combine.....	7	8.1	Inspection .....	21
4.5	Names and functions of parts .....	7	8.2	Warranty .....	21
5	Installation .....	8	8.3	Disposal .....	21
5.1	Installation location.....	8	9	Troubleshooting .....	22
5.2	Installing the driver .....	8	10	Alarms.....	23
6	Connection .....	9	10.1	Alarm reset .....	23
6.1	Connecting the motor and driver (CN3).....	9	10.2	Alarm lists.....	24
6.2	Connecting the power supply (CN1).....	9	11	Specifications .....	25
6.3	Connecting the I/O signals (CN2).....	10	11.1	Specifications.....	25
6.4	Driver I/O circuit.....	11	11.2	General specifications .....	26
6.5	Connecting external analog setting devices .....	12	11.3	Dimension.....	26
6.6	Grounding .....	12	12	Regulations and standards .....	27
6.7	Connection diagram .....	13	12.1	UL Standards and CSA Standards.....	27
6.8	Noise measures.....	14	12.2	EU Directives .....	27
6.9	Conformity to the EMC Directive.....	15	12.3	Republic of Korea, Radio Waves Act .....	27
			12.4	RoHS Directive.....	27

# 1 Introduction

---

## ■ Before using the product

Only qualified personnel of electrical and mechanical engineering should work with the product.

Use the product correctly after thoroughly reading the section "2 Safety precautions." In addition, be sure to observe the contents described in warning, caution, and note in this manual.

The product described in this manual has been designed and manufactured to be incorporated in general industrial equipment. Do not use for any other purpose. For the power supply, use a DC power supply with reinforced insulation on its primary and secondary sides. Oriental Motor Co., Ltd. is not responsible for any damage caused through failure to observe this warning.

## ■ Operating manuals for the product



Operating manuals for the **BLH** Series are listed below.

Operating manuals are not included with the product. Download from Oriental Motor Website Download Page or contact your nearest Oriental Motor sales office.

	Operating manual name	Operating manual number
Driver	<b>BLH</b> Series Analog Setting Type OPERATING MANUAL (this document)	HP-5072
Motor	<b>BLHM</b> Motor OPERATING MANUAL	HM-5238
	<b>BLHM</b> Electromagnetic Brake Motor OPERATING MANUAL	HM-5258
	DC Power Input Drivers <b>BLM</b> Motor Connector type OPERATING MANUAL	HM-5267



## 2 Safety precautions



The precautions described below are intended to ensure the safe and correct use of the product, and to prevent the user and other personnel from exposure to the risk of injury. Use the product only after carefully reading and fully understanding these instructions.

 <b>WARNING</b>	Handling the product without observing the instructions that accompany a "WARNING" symbol may result in serious injury or death.
 <b>CAUTION</b>	Handling the product without observing the instructions that accompany a "CAUTION" symbol may result in injury or property damage.
 <b>Note</b>	The items under this heading contain important handling instructions that the user should observe to ensure safe use of the product.

Explanation of graphic symbols  Indicates "prohibited" actions that must not be performed.

 Indicates "compulsory" actions that must be performed.

 <b>WARNING</b>	
	<ul style="list-style-type: none"> <li>• Do not use the product in explosive or corrosive environments, in the presence of flammable gases, in places subjected to splashing water, or near combustibles. Doing so may result in fire or injury.</li> <li>• Do not transport, install, connect or inspect the product while the power is supplied. Always turn off the power before carrying out these operations. Damage to equipment may result.</li> <li>• Do not use a motor in vertical drive such as elevating equipment. When the driver protective function is activated, the motor will stop operating. The moving part may fall, leading to injury or damage to equipment.</li> <li>• Do not touch the motor or driver when conducting the insulation resistance measurement or dielectric strength test. Accidental contact may result in electric shock.</li> <li>• Do not disassemble or modify the driver. Doing so may cause injury or damage to equipment. Refer all such internal inspections and repairs to the branch or sales office from which you purchased the product.</li> </ul>
	<ul style="list-style-type: none"> <li>• Only qualified and educated personnel should be allowed to perform installation, connection, operation and inspection/troubleshooting of the product. Handling by unqualified and uneducated personnel may result in fire, injury or damage to equipment.</li> <li>• Use a motor and driver only in the specified combination. Failure to do so may result in fire or damage to equipment.</li> <li>• If the driver protective function was activated, remove the cause before resetting the protective function. Continuing the operation without removing the cause of the problem may cause malfunction of the motor, leading to injury or damage to equipment.</li> <li>• Install the driver in an enclosure. Failure to do so may result in injury.</li> <li>• Always keep the power supply voltage of the driver within the specified range. Failure to do so may result in fire.</li> <li>• Connect the cables securely according to the wiring example. Failure to do so may result in fire or damage to equipment.</li> <li>• Be sure to observe the specified cable sizes. Failure to do so may result in fire or damage to equipment.</li> <li>• For the driver power supply, use a DC power supply with reinforced insulation on its primary and secondary sides. Failure to do so may result in electric shock.</li> <li>• If the motor is operated by turning on and off the power supply, turn off the driver power in the event of a power failure. Otherwise, the motor may suddenly start when the power is restored, causing injury or damage to equipment.</li> <li>• Always turn off the power before performing maintenance or inspection. Failure to do so may result in electric shock.</li> </ul>

 <b>CAUTION</b>	
	<ul style="list-style-type: none"> <li>• Do not use the driver beyond the specifications. Doing so may result in fire, injury or damage to equipment.</li> <li>• Do not touch the driver during operation or immediately after stopping. The surface is hot, and this may cause a skin burn(s).</li> <li>• Keep the area around the driver free of combustible materials. Failure to do so may result in fire or a skin burn(s).</li> <li>• Do not leave anything around the driver that would obstruct ventilation. Doing so may result in damage to equipment.</li> <li>• Do not shut off the negative side of the power supply. Also, make sure that the wiring for the power supply does not disconnect. This may result in damage to equipment.</li> </ul>
	<ul style="list-style-type: none"> <li>• Securely install the driver to the mounting plate. Inappropriate installation may cause the driver to detach and fall, resulting in injury or damage to equipment.</li> <li>• Be sure to ground the motor and driver to prevent them from being damaged by static electricity. Failure to do so may result in fire or damage to equipment.</li> <li>• Pay enough attention to safe operation when starting and stopping the motor by switching ON-OFF of the power supply. Failure to do so may result in injury or damage to equipment.</li> <li>• Provide an emergency stop device or emergency stop circuit external to the equipment so that the entire equipment will operate safely in the event of a system failure or malfunction. Failure to do so may result in injury.</li> <li>• Immediately when trouble has occurred, stop operation and turn off the driver power. Failure to do so may result in fire, electric shock or injury.</li> <li>• Before turning on the power to the driver, make sure to turn all input signals of the driver to OFF. Otherwise, the motor may suddenly start when the power is on, leading to injury or damage to equipment.</li> </ul>

## 3 Precautions for use

---

This chapter covers limitations and requirements the user should consider when using the product.

Use a driver and motor only in the specified combination.

Refer to "4.4 Products possible to combine" on p.7 for combinations of the driver and motor.

- Do not perform gravitational operation (vertical drive).  
If the **BLH** Series is used in operation (i.e. gravitational operation) in which the motor output shaft is turned from the load side, the motor speed cannot be controlled. Also, do not use the motor in vertical drive such as elevating equipment because it has no holding force. Doing so may cause a load to drop when the motor stops.
- Do not conduct the insulation resistance measurement or the dielectric strength test with the motor and driver connected.  
Conducting the insulation resistance measurement or the dielectric strength test with the motor and driver connected may result in damage to the product.
- Note on power ON/OFF using a mechanical contact  
When turning on or off the power supply using a mechanical contact (breaker, electromagnetic switch, relay, etc.), do so only the positive side (+) of the power supply using the mechanical contact.  
Turning on or off the positive side (+) and the negative side (–) of the power supply simultaneously using a mechanical contact may cause damage to the control circuit or peripheral equipment.  
Refer to p.10 for details.
- Noise elimination measures  
Refer to p.14 for the noise elimination measures.
- Grease measures  
On rare occasions, grease may ooze out from the gearhead. If there is concern over possible environmental contamination resulting from the leakage of grease, check for grease stains during regular inspections. Alternatively, install an oil pan or other device to prevent damage resulting from contamination. Grease leakage may lead to problems in the user's equipment or products.
- Apply grease to the hollow output shaft of a hollow shaft flat gearhead.  
Apply grease (molybdenum disulfide grease, etc.) on the surface of the load shaft and the inner walls of the hollow output shaft to prevent seizure.
- Sliding noise of electromagnetic brake  
Sliding noise of the brake disk for the electromagnetic brake motor may be generated during operation.  
It is no functional problem.

# 4 Preparation

This chapter explains the items you should check, as well as the name and function of each part.

## 4.1 Checking the product

Verify that the items listed below are included.

Report any missing or damaged items to the branch or sales office from which you purchased the product. Refer to "4.4 Products possible to combine" for combinations of the driver and motor.

- Driver ..... 1 unit                       Instructions and Precautions for Safe Use..... 1 copy

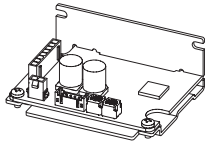

## 4.2 How to identify the product model

**BLH2D 30 D H - K \_**

①                      ②                      ③                      ④                      ⑤                      ⑥

①	Driver type	<b>BLH2D: BLH Series driver</b>
②	Output power	<b>15: 15 W 30: 30 W 50: 50 W</b>
③	Identification code	<b>D</b>
④	Motor connection method	Blank: Cable type <b>H</b> : Connector type
⑤	Power supply voltage	<b>K: 24 VDC</b>
⑥	Blank: Analog setting type <b>D</b> : Digital setting type <b>R</b> : RS-485 communication type	

## 4.3 Information about nameplate

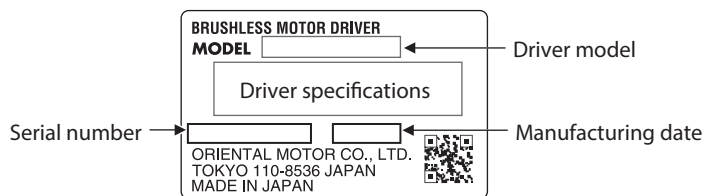

## 4.4 Products possible to combine

Products with which the drivers can be combined are listed below.

Verify the driver model and the motor model against the model name described on the nameplate of the product. Motor model columns in the table below describes part of the motor model name.

For details about the motor, refer to the operating manual of the motor.

Applicable motor	Output power	Driver model	Motor model	Cable set model
BLHM Motor	15 W	<b>BLH2D15-K</b>	<b>BLHM015</b>	<b>LHS003CC</b> or <b>LHS010CC</b>
	30 W	<b>BLH2D30-K</b>	<b>BLHM230</b>	
	50 W	<b>BLH2D50-K</b>	<b>BLHM450</b>	
BLM Motor	15 W	<b>BLH2D15H-K</b>	<b>BLM015HK</b>	
	30 W	<b>BLH2D30DH-K</b>	<b>BLM030DHK</b>	
		<b>BLH2D30H-K</b>	<b>BLM230HK</b>	
	50 W	<b>BLH2D50DH-K</b>	<b>BLM250DHK</b>	
<b>BLH2D50H-K</b>		<b>BLM450HK</b>		

- Cable set (Each cable can be purchased separately.)
  - I/O signal cable ..... 1 pc
  - Power supply cable ..... 1 pc



Length	Cable set model	I/O signal cable	Power supply cable
300 mm (11.8 in.)	<b>LHS003CC</b>	LH003C3	LH003C1
1000 mm (39.4 in.)	<b>LHS010CC</b>	LH010C3	LH010C1

## 4.5 Names and functions of parts

This section explains the name and function for each part of the driver.

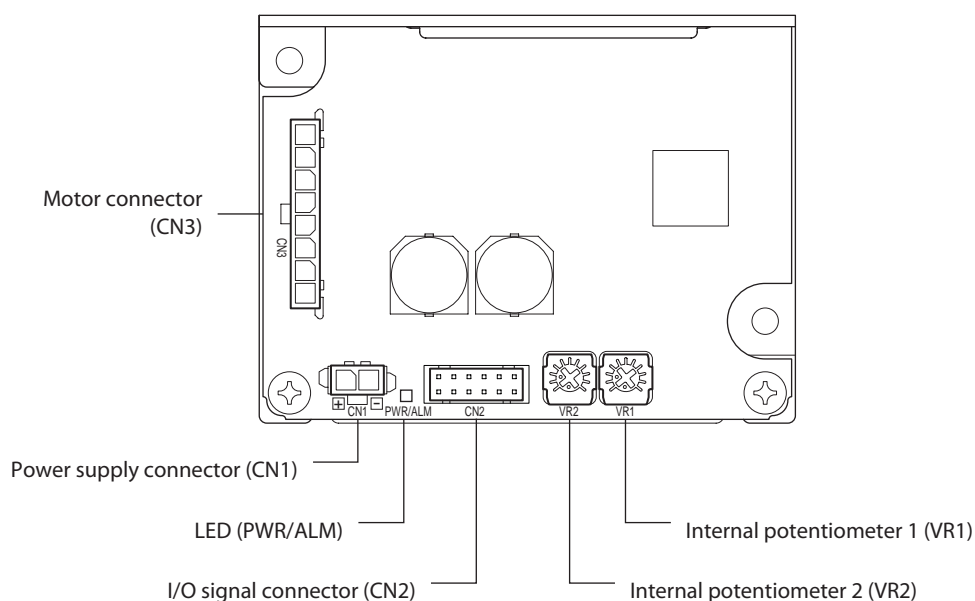

Name	Indication	Description
Power supply connector	CN1	Connects the power supply cable.
I/O signal connector	CN2	Connects the I/O signal cable to connect with an external control device.
Motor connector	CN3	Connects the motor cable.
LED	PWR/ALM	Lit in green while the power is supplied.
		If an alarm is generated, this LED will blink in red. The generated alarm content can be checked by counting the number of times the LED blinks.
Internal potentiometer	VR1	Sets the rotation speed. (M0 input: ON)
	VR2	Sets the acceleration time and deceleration time.

# 5 Installation

## 5.1 Installation location

The driver is designed and manufactured to be incorporated in equipment.

Install it in a well-ventilated location that provides easy access for inspection. The location must also satisfy the following conditions:

- Inside an enclosure that is installed indoors (provide vent holes)
- Operating ambient temperature: 0 to +50°C [+32 to +122 °F] (non-freezing)
- Operating ambient humidity: 85% or less (non-condensing)
- Area that is free of explosive atmosphere or toxic gas (such as sulfuric gas) or liquid
- Area not exposed to direct sun
- Area free of excessive amount of dust, iron particles or the like
- Area free of excessive salt
- Area not subject to splashing water (rain, water droplets), oil (oil droplets) or other liquids
- Area not subject to continuous vibration or excessive shocks
- Area free of excessive electromagnetic noise (from welders, power machinery, etc.)
- Area free of radioactive materials, magnetic fields or vacuum
- Altitude: Up to 1000 m (3300 ft.) above sea level

## 5.2 Installing the driver

### ■ Installation direction

The driver is designed on the basis of heat radiation by air convection and heat conduction to an enclosure.

When installing the driver in an enclosure, be sure to use the mounting holes on the driver, and install it in a vertical direction or horizontal direction.

#### ● Vertical installation

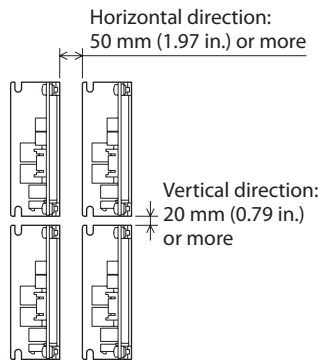

#### ● Horizontal installation

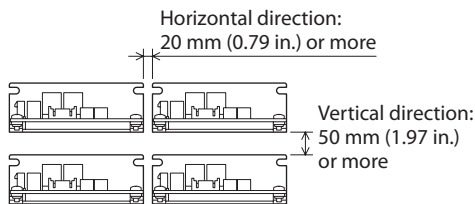

- Drivers can be installed as shown in the figure below.

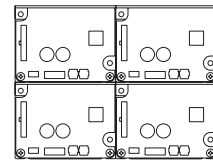

Both the vertical installation and the horizontal installation are available.

### ■ Installation method

Install the driver onto an appropriate flat metal plate having excellent vibration resistance and heat conductivity.

Using the mounting holes or notches of the driver, secure it with two screws (M3: not included) so as not to leave a gap between the driver and metal plate.

#### Note

- Do not install any equipment that generates a large amount of heat or noise near the driver.
- If the ambient temperature of the driver exceeds the upper limit of the operating ambient temperature, reconsider the ventilation condition or forcibly cool the area around the driver using a fan in order to keep within the operating ambient temperature.



# 6 Connection

This chapter explains how to connect the driver with the motor, power supply, and I/O signals.

## 6.1 Connecting the motor and driver (CN3)

Insert the motor cable connector into the motor connector (CN3) on the driver.

When extending the motor cable, use a connection cable (sold separately).

The maximum extension distance including the cable length of the motor itself should be 2 m (6.6 ft.).



- Firmly insert the connector in position. Insecure connector connection may cause malfunction or damage to the motor or driver.
- Be sure to insert and pull out the connector while holding the connectors part. Do not apply any force in a direction other than the direction of inserting and pulling out the connector. Applying improper force may cause damage to the connector and driver.

### CN3 pin assignment

Pin No.	Lead wire color*	Lead wire size
1	Gray (Black)	AWG22
2	Purple	
3	Blue	
4	Yellow	AWG26
5	Green	
6	Orange	
7	Red	
8	Brown (White)	

Viewed from the direction of an arrow in the right figure

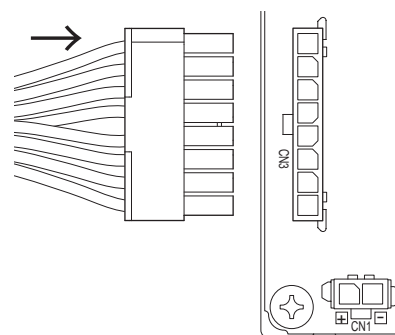
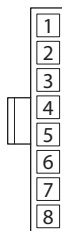

\* The color in parentheses ( ) indicates the 15 W type.

- Housing 43645-0800 (molex)
- Terminal AWG22, 24: 43030-0001 (molex)  
AWG26: 43030-0004 (molex)

For lead wire type and connector type, all lead wire sizes are AWG22 (15W: AWG24).

## 6.2 Connecting the power supply (CN1)

Insert the power supply cable connector into the power supply connector (CN1) on the driver.

Lead wire size: AWG22 (0.3 mm<sup>2</sup>)



- When connecting, pay attention to the polarity of the power supply. Connection with incorrect polarity may cause damage to the driver.
- Do not wire the power supply cable of the driver in the same cable duct with other power lines or motor cables.
- When turning on the power again or inserting/pulling out the motor cable connector, turn off the power and wait for at least 5 seconds before doing so.

### CN1 pin assignment

Pin No.	Lead wire color	Lead wire size
1	Red	AWG22
2	Black	

Viewed from the direction of an arrow in the right figure



Housing: 43645-0200 (molex)  
Terminal: 43030-0001 (molex)

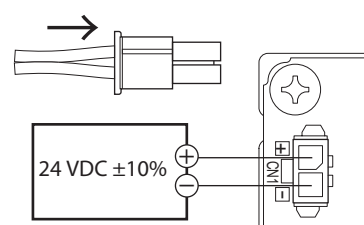

**Note on power ON/OFF using a mechanical contact**

- When turning on or off the power supply using a mechanical contact (breaker, electromagnetic switch, relay, etc.), do so only the positive side (+) of the power supply using the mechanical contact.

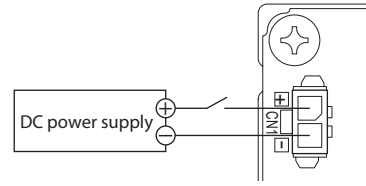

Do not turn on or off the positive side (+) and the negative side (-) of the power supply simultaneously or shut off only the negative side (-) of the power supply.

The main circuit and the control circuit in the driver are connected to the same ground. So the input current of the main circuit flows round into the control circuit when the power supply is turned on or off, causing damage to the control circuit or peripheral equipment.

### 6.3 Connecting the I/O signals (CN2)

Insert the connector of the I/O signal cable into the I/O signal connector (CN2) of the driver.  
Lead wire size: AWG26 (0.14 mm<sup>2</sup>)

**CN2 pin assignment**

Viewed from the direction of an arrow in the right figure

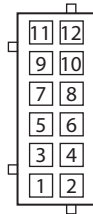

Housing: PHDR-12VS (JST)  
Terminal: SPHD-001T-P0.5 (JST)

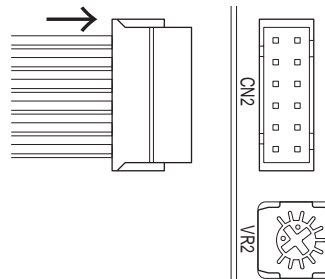

Pin No.	Lead wire color	Terminal name	Signal name	Description
12	-	-	-	Not connected.
11	Black	DIN0	START/STOP	These signals are used to operate the motor. The motor rotates according to the acceleration time when both the START/STOP input and the RUN/BRAKE input are turned ON. If the START/STOP input is turned OFF, the motor stops according to the deceleration time. If the RUN/BRAKE input is turned OFF, the motor stops instantaneously.
10	White	DIN1	RUN/BRAKE	
9	Gray	DIN2	FWD/REV	This signal is used to change the motor rotation direction. The motor rotates in the CW direction when this signal is turned ON, and in the CCW direction when it is turned OFF. *
8	Light blue	DIN3	M0	When the M0 input is ON, the setting speed of the internal potentiometer (VR1) is enabled. When it is OFF, the setting speed of the external analog setting device (external potentiometer or external DC voltage) is enabled.
7	Purple	DIN4	ALM-RST	This signal is used to reset the alarm. (The alarm will be reset at the OFF edge of the input.)
6	Blue	VH	External analog setting device	These signals are used when the rotation speed is externally set using an external analog setting device (external potentiometer or external DC voltage).
5	Green	VM		
4	Yellow	VL		
3	Orange	GND	GND	I/O signals common
2	Red	DOUT0	SPEED-OUT	30 pulses are output while the motor output shaft makes one revolution in synchronization with the motor rotation. The pulse width of output pulse signals is 0.3 ms. The motor rotation speed can be calculated using the SPEED-OUT output. $\text{Frequency of SPEED-OUT (Hz)} = \frac{1}{T}$ $\text{Rotation speed (r/min)} = \frac{\text{Frequency of SPEED-OUT}}{30} \times 60$
1	Brown	DOUT1	ALM-B	This is a signal to output an alarm status. It is turned OFF when an alarm is generated. (Normally closed) The generated alarm content can be checked by counting the number of times the LED blinks. Refer to p.23 for details.

\* The rotation direction varies depending on the gear ratio of gearhead.

## 6.4 Driver I/O circuit

### Input signals circuit

Input signals of the driver are C-MOS inputs.

The signal state represents "ON: 0 to 0.5 V (L level)" and "OFF: 4 to 5 V (H level)."

- External control device output is a 5 V C-MOS output

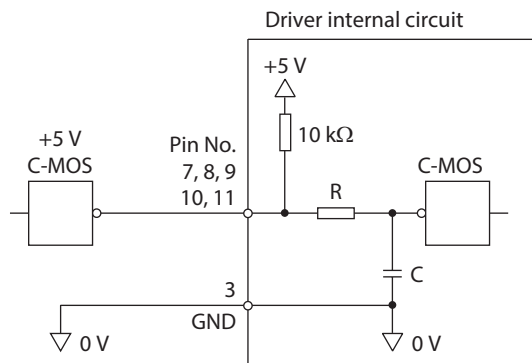

- External control device output is an open-collector output

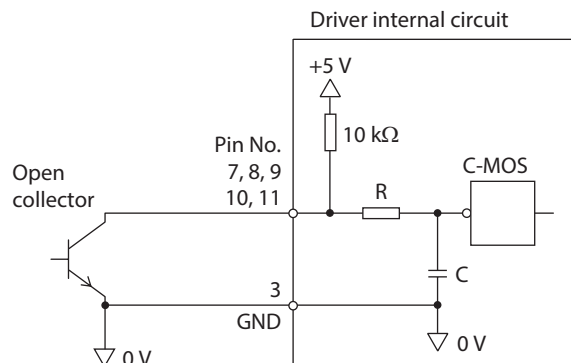

- Switch connection

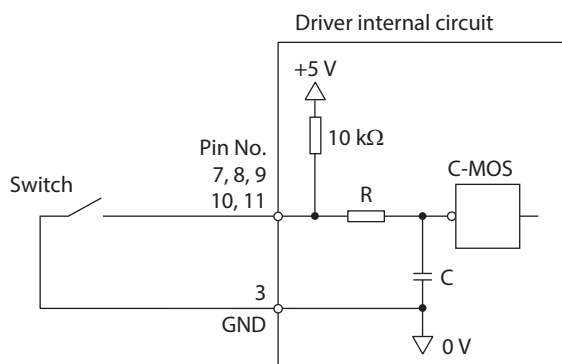

### Output signals circuit

Output signals of the driver are transistor open-collector outputs. The signal state represents a state of "ON: Carrying current" or "OFF: Not carrying current" for the internal photocoupler rather than the voltage level of the signal.

ON voltage: 0.5 VDC maximum

External power supply: 4.5 to 26.4 VDC, 10 mA or less

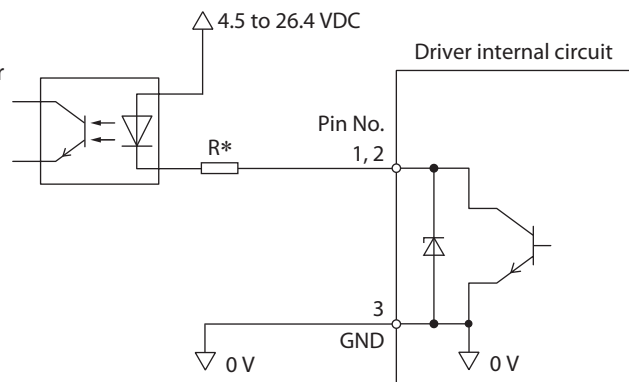

\* Recommended resistance value when a current limiting resistor R is connected:

For 24 VDC: 2.7 kΩ to 4.7 kΩ (1 W)

For 5 VDC: 560 Ω to 820 Ω (0.25 W)

### Note

- Be sure to suppress a current flowing to the output circuit at 10 mA or less. Connect a current limiting resistor R externally if the current exceeds this specified value. If the driver is used without connecting a current-limiting resistor, it will be damaged.
- When a relay (inductive load) is connected, provide a control measure for the fly-back voltage against the relay by connecting a diode. Or use a relay with built-in flywheel diode.

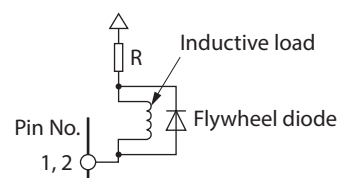

## 6.5 Connecting external analog setting devices

The rotation speed can be set using an external potentiometer (sold separately) or external DC voltage.

### ■ Using an external potentiometer

Connect to the pin No.4 to No.6 of the CN2.



When the **PAVR2-20K** is used, use the ferrule (rod terminal).  
 Manufacturer: PHOENIX CONTACT GmbH & Co. KG  
 Model: AI 0,14-8 [AWG26 (0.14mm<sup>2</sup>)]

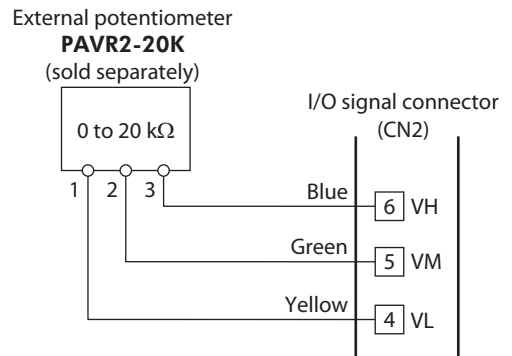

When a shielded cable is used for connection with the external potentiometer, connect shields to VL of the pin No.4 from near the I/O signal connector (CN2).

### ■ Using external DC voltage

For the external voltage, use a DC power supply (0 to 5 VDC) with reinforced insulation on its primary and secondary sides, and connect to the pin No.4 and No.5 of the CN2.

Input impedance between the VM input and VL input is approximately 47 kΩ.

The VL input is connected to GND inside the driver.

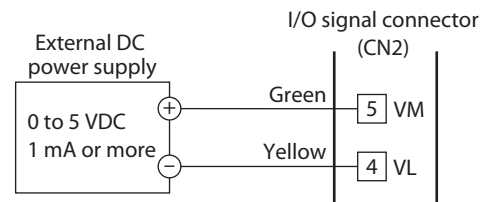

- Be sure to use the voltage of an external control device at 5 VDC or lower. When connecting an external control device, make sure the polarities are correct. If the polarities are reversed, the driver may be damaged.
- When a shielded cable is used for connection with the external control device, connect shields to VL of the pin No.4 from near the I/O signal connector (CN2).

## 6.6 Grounding

The wire used to ground the motor and driver must be as thick and short to the grounding point as possible so that no potential difference is generated. Choose a large, thick and uniformly conductive surface for the grounding point.

### ● Grounding the driver

Install the driver to a metal surface that has grounded.

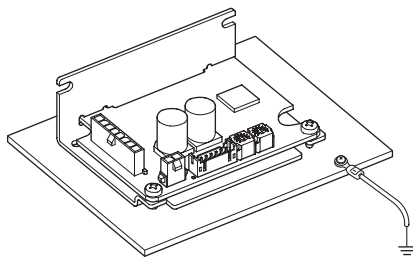

## 6.7 Connection diagram

The figure shows an example when an external potentiometer is connected.

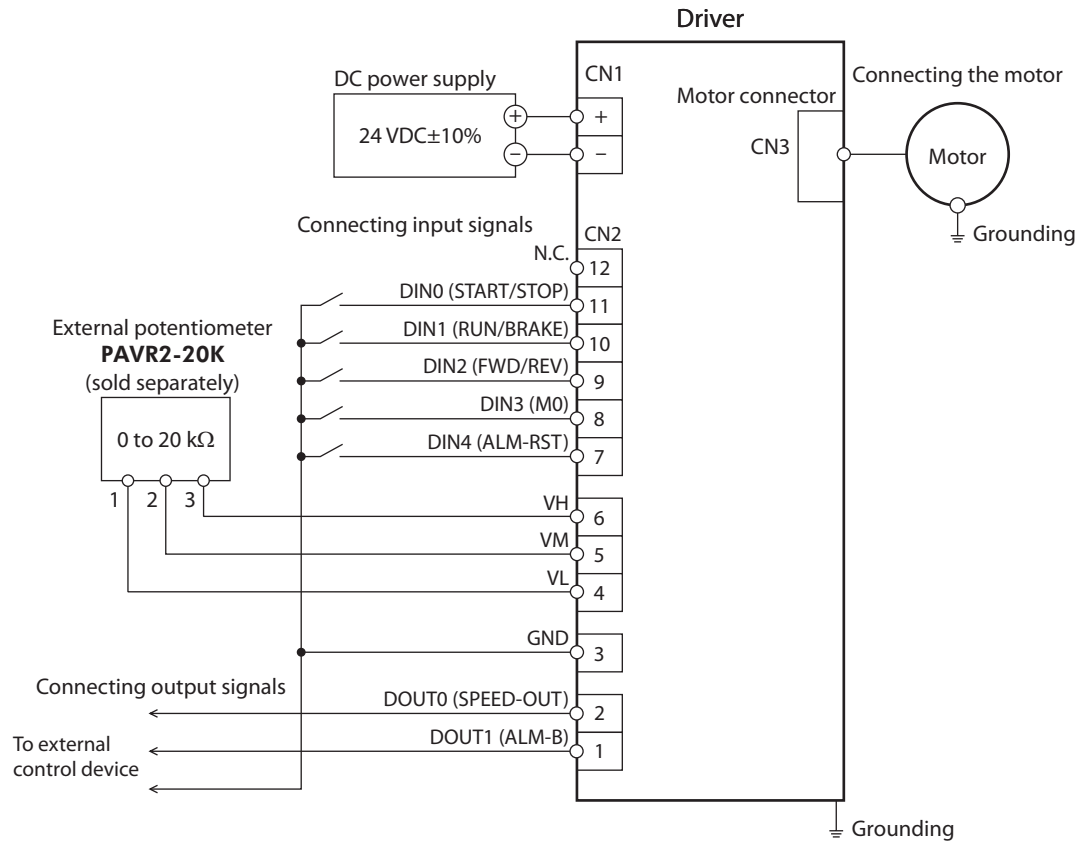

**Note** Insulate unused lead wires which are on the opposite side to the connector of the I/O signal cable to prevent them from contacting other devices, or connect them to 5 VDC or the signal ground (GND) of your external control device according to usage of signals.

## 6.8 Noise measures

There are two types of electrical noises: One is a noise to invade into the driver from the outside and cause the driver malfunction, and the other is a noise to emit from the driver and cause peripheral equipments malfunction.

For the noise that is invaded from the outside, take measures to prevent the driver malfunction. It is needed to take adequate measures because signal lines are very likely to be affected by the noise.

For the noise that is emitted from the driver, take measures to suppress it.

### Measures against electrical noise

There are the following three methods mainly to take measures against the electrical noise.

#### ● Noise suppression

- When relays or electromagnetic switches are used, use noise filters or CR circuits to suppress surge generated by them.
- Use a connection cable (sold separately) when extending the wiring distance between the motor and the driver. This is effective in suppressing the electrical noise emitted from the motor.
- Cover the driver by a metal plate such as aluminum. This is effective in shielding the electrical noise emitted from the driver.

#### ● Prevention of noise propagation

- Separate power lines such as motor cable and power supply cable from signal lines for a distance of 100 mm (3.94 in.) or more, and also do not bundle them or wire them in parallel. If the power lines must cross over the signal lines, wire them at right angles.
- Use a cable of AWG26 (0.14 mm<sup>2</sup>) or thicker for the signal cable of the driver, and keep the wiring distance of 3 m (9.8 ft.) or less.
- For more effective elimination of noise, use shielded cables for a power supply cable and I/O signal cable, or attach ferrite cores if non-shielded cables are used.
- Keep cables as short as possible without coiling and bundling extra lengths.
- To ground a shielded cable, use a metal cable clamp that can maintain contact with the entire circumference of the shielded cable, and ground as near the product as possible.

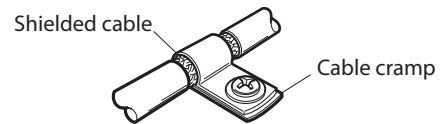

- Grounding multiple points will increase effect to block electrical noise because impedance on the grounding points is decreased. However, ground them so that a potential difference does not occur among the grounding points.

#### ● Suppression of effect by noise propagation

- Loop the noise propagated cable around a ferrite core. Doing so will prevent the propagated noise invades into the driver or emits from the driver. The frequency band in which an effect by the ferrite core can be seen is generally 1 MHz or more. Check the frequency characteristics of the ferrite core used. When increasing the effect of noise attenuation by the ferrite core, loop the cable a lot.

## 6.9 Conformity to the EMC Directive

Effective measures must be taken against the EMI that the motor and driver may give to adjacent control-system equipment, as well as the EMS of the motor and driver itself, in order to prevent a serious functional impediment in the machinery. The use of the following installation and wiring methods will enable the motor and driver to be compliant with the EMC directive. Refer to p.27 for the applicable standards.

Oriental Motor conducts EMC measurements on its motors and drivers in accordance with "Example of installation and wiring" shown on the next page.

The user is responsible for ensuring the machine's compliance with the EMC Directive, based on the installation and wiring explained below.

### ■ About power supply

The **BLH** Series is a product of DC power supply input. Use a DC power supply (such as a switching power supply) that optimally conforms to the EMC Directive.

### ■ Connecting the motor cable

When extending the motor cable, use an connection cable (sold separately). The maximum extension distance including the cable length of the motor itself should be 2 m (6.6 ft.).

### ■ Ferrite core

Use a ferrite core to suppress effect by noise propagation.

Use 7427122 (Würth Elektronik GmbH & Co.KG), ZCAT3035-1330 (TDK Corporation) or equivalent ferrite cores.

Install the ferrite cores close to the motor and driver, respectively.

### ■ Wiring the I/O signal cable

Refer to "Prevention of noise propagation" on p.14.

### ■ Notes about installation and wiring

- Connect the motor, driver and other peripheral control equipment directly to the grounding point so as to prevent a potential difference from developing between grounds.
- When relays or electromagnetic switches are used together with the system, use noise filters and CR circuits to suppress surges generated by them.
- Keep a power supply cable and signal cable as short as possible without coiling and bundling extra lengths.
- Separate power lines such as motor cable and power supply cable from signal lines, and wire them apart as much as possible [example: about 100 to 200 mm (3.94 to 7.87 in.)]. If the power lines must cross over the signal lines, wire them at right angles.

■ Example of installation and wiring

- Driver model: **BLH2D15-K, BLH2D30-K, BLH2D50-K**

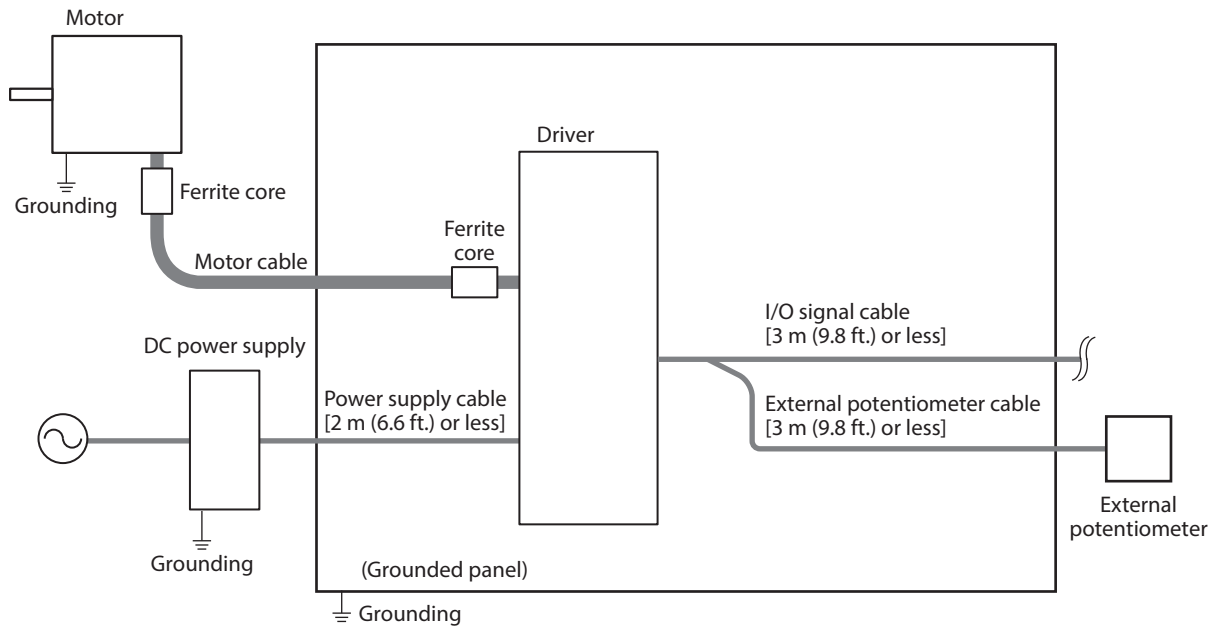

- Driver model: **BLH2D15H-K, BLH2D30DH-K, BLH2D30H-K, BLH2D50DH-K, BLH2D50H-K**

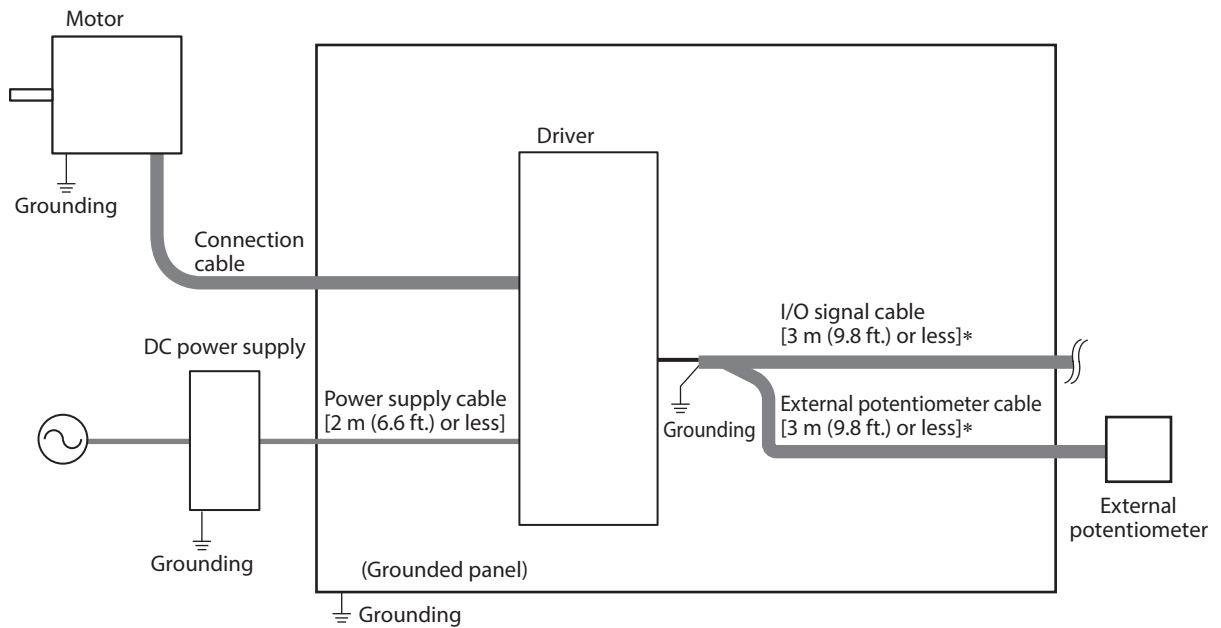

\* Shielded cable

■ Precautions about static electricity

Static electricity may cause the driver to malfunction or suffer damage. Be careful when handling the driver while the power is supplied.

Always use an insulated screwdriver to adjust the internal potentiometers of the driver.

**Note** Do not approach or touch the driver while the power is supplied.



# 7 Operation

## 7.1 Setting the rotation speed

The rotation speed can be set using the external analog setting device (external potentiometer or external DC voltage) or VR1.

Whether to use the external analog setting device or VR1 can be selected by switching the ON/OFF status of the M0 input. The setting range is 100 to 3000 r/min.

M0 input	OFF	ON
Speed setting	External analog setting device	VR1

### External potentiometer

An external potentiometer is used when the speed is set from a place away from the driver. Use the **PAVR2-20K** (sold separately) for an external potentiometer.

External potentiometer

**PAVR2-20K**  
(sold separately)

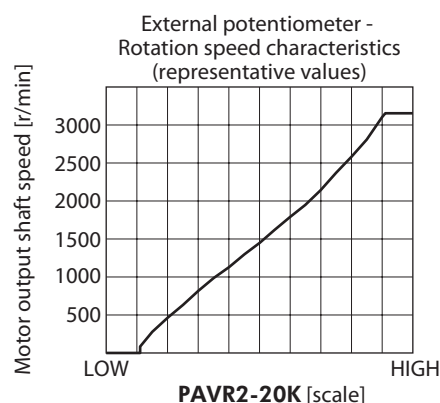
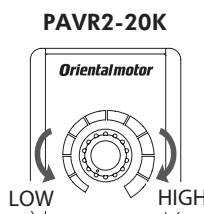
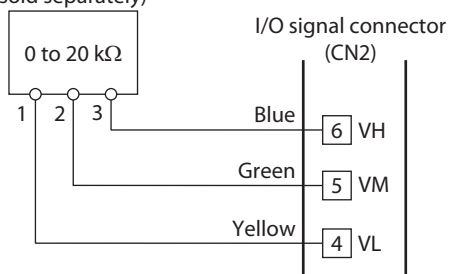

### External DC voltage

Use when the speed is set by DC voltage from an external control device. For the external DC voltage, use a DC power supply (0 to 5 VDC, 1 mA or more) with reinforced insulation on its primary and secondary sides.

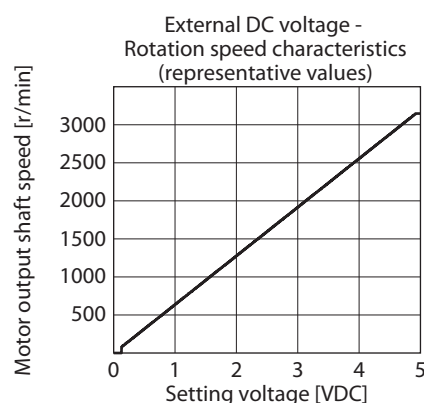
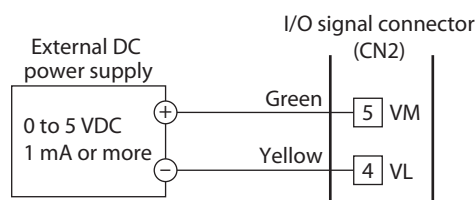

### VR1

The internal potentiometer VR1 is used when the rotation speed is not changed frequently or an operation by switching two-level speeds is performed in combination with the external analog setting device. Adjust the potentiometer using an insulated screwdriver. Factory setting: 0 r/min

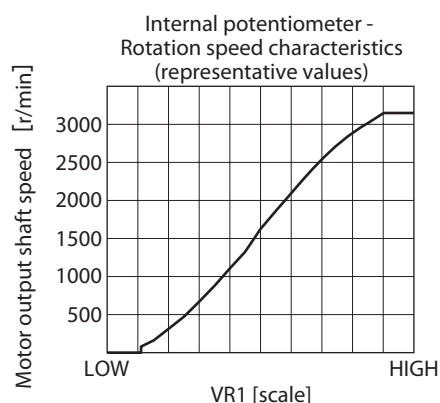
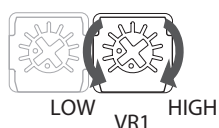

## 7.2 Setting the acceleration time and deceleration time

The acceleration time and deceleration time can be set so that an impact is not applied to a load when the motor starts or stops.

The acceleration time is set as a time needed for the motor to reach the rated rotation speed from a standstill state. The deceleration time is set as a time needed for the motor to stop from the rated rotation speed.

The actual acceleration time and deceleration time are affected by customer's conditions of use, load inertia, and load torque.

The setting range is 0.1 s to 12.0 s.

Factory setting: 0.1 s

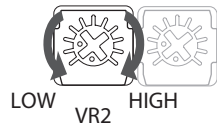

Internal potentiometer - Acceleration/ deceleration time characteristics (representative values)

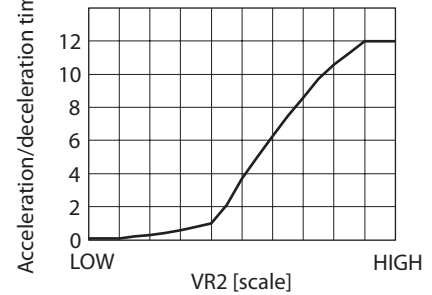

## 7.3 Operation and stop

Use the START/STOP input and the RUN/BRAKE input to operate or stop the motor.

	START/STOP input	RUN/BRAKE input	Motor operation
Signal level	ON	ON	Operation
	ON	OFF	Instantaneous stop
	OFF	ON	Deceleration stop

If the RUN/BRAKE input is turned OFF during deceleration stop, the motor stops instantaneously.

Deceleration stop: The motor decelerates to a stop according to a time set in the deceleration time.

Instantaneous stop: The motor stops at the shortest time without following the deceleration time.

### ■ START/STOP input, RUN/BRAKE input

The motor rotates when both the START/STOP input and the RUN/BRAKE input are turned ON.

If the START/STOP input is turned OFF while the motor rotates, the motor decelerates to a stop according to the setting of the VR2.

If the RUN/BRAKE input is turned OFF while the motor rotates, the motor stops at the shortest time (instantaneous stop).

### ■ FWD/REV input

This is a signal to change the motor rotation direction. The motor rotates in the CW direction when this signal is turned ON, and in the CCW direction when it is turned OFF.



- When the START/STOP input and the RUN/BRAKE input are turned OFF simultaneously, the RUN/BRAKE input is prioritized.
- The actual acceleration time and deceleration time are affected by customer's conditions of use, load inertia, and load torque.

### ■ Examples of operation patterns

The figure shows an example when the external potentiometer is set to 2000 r/min and the VR1 is set to 650 r/min. The rotation direction show the round shaft type. It varies depending on the gear ratio of gearhead.

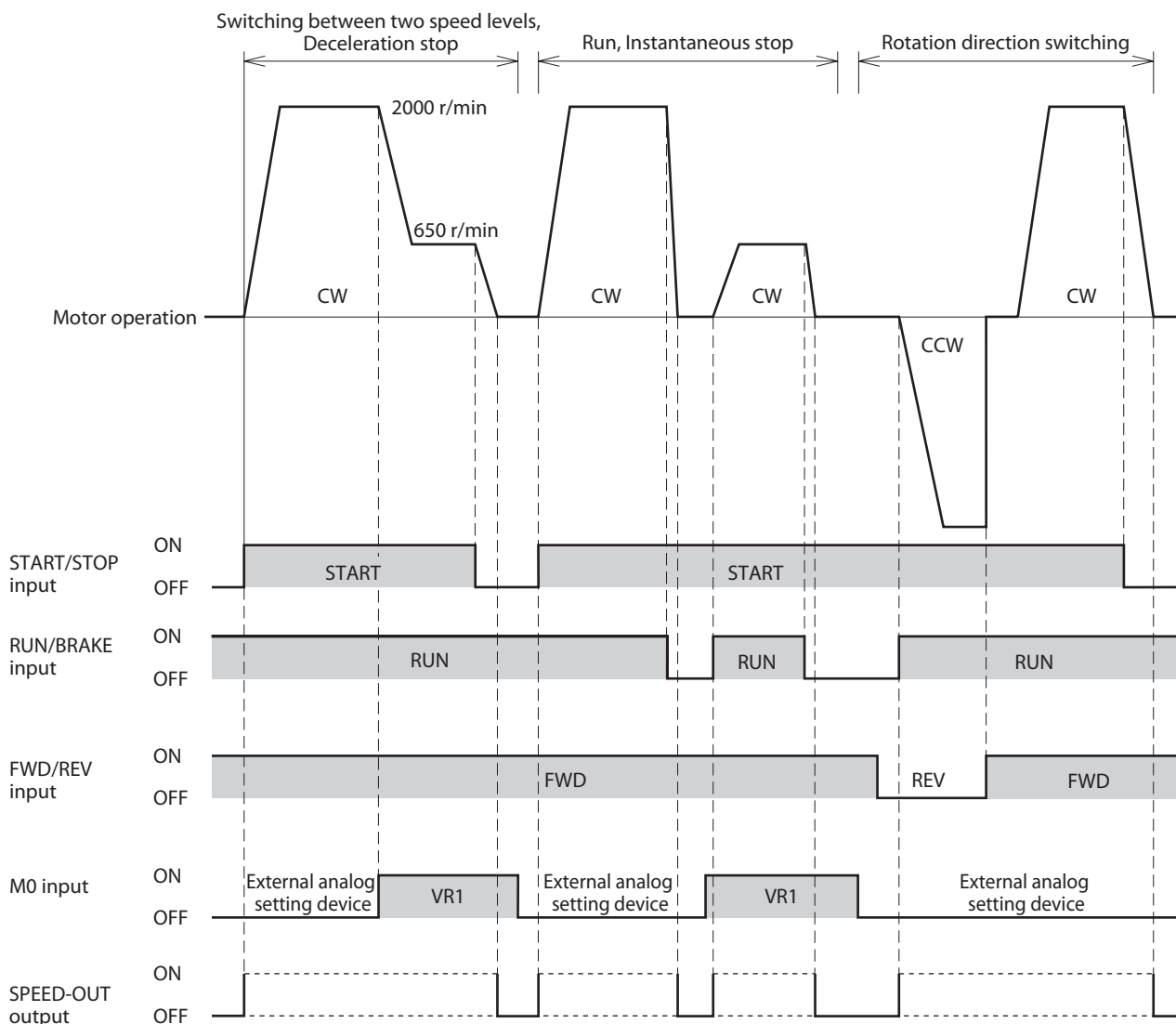

**Note** To surely recognize the input signal, ensure the ON time and OFF time of each input signal for at least 10 ms.

#### ● Timing chart when power is input

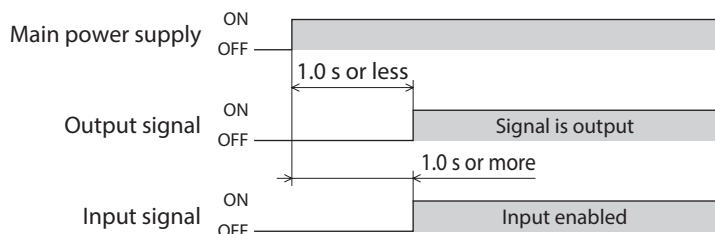

## 7.4 Rotation direction of the motor output shaft

The rotation direction of the motor output shaft represents the direction when viewed from the motor output shaft.

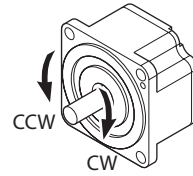

### Rotation direction of the gearhead output shaft

The rotation direction of the gearhead output shaft varies depending on the type or the gear ratio of the gearhead. Check the operating manual of the motor for the rotation direction of the gearhead output shaft.

## 7.5 Multi-motor control

Operating two or more motors at the same speed can be performed using either an external potentiometer or external DC voltage.

Using an external potentiometer

Use common lines for the power supply and speed setting, and set the speed using VRx as shown in the figure below.

- Obtain the resistance value for the external speed potentiometer as follows.

Resistance VRx when the number of drivers is n units:  $VRx (k\Omega) = 20 k\Omega/n$ , permissible dissipation (W) =  $n/20$

Example: If two drivers are connected, 10 kΩ and 1/10 W are obtained.

- For I/O signals other than the speed setting, connect for each driver.
- If multiple motors are used with speed differences among them, adjust as follows.  
The first driver: Connect a resistor of 1.5 kΩ, 1/20 W to the terminal M on the driver.  
The second and subsequent drivers: Connect a variable resistor (VRn) of 5 kΩ, 1/20 W to the terminal M on the driver.
- Keep the number of drivers to 10 units or less in multi-motor control using an external potentiometer.

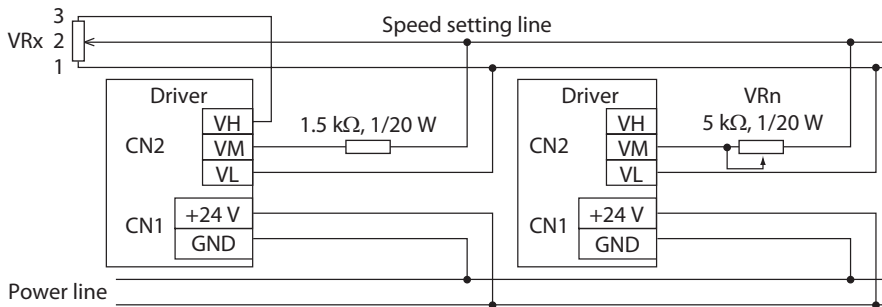

Using external DC voltage

- Use a DC power supply whose current capacity is at least the value calculated by the formula below.

Current capacity (mA) when the number of drivers is n units =  $1 mA \times n$

Example: If two drivers are connected, the current capacity should be at least 2 mA.

- For I/O signals other than the speed setting, connect for each driver.
- If multiple motors are used with speed differences among them, adjust as follows.  
The first driver: Connect a resistor of 1.5 kΩ, 1/20 W to the terminal M on the driver.  
The second and subsequent drivers: Connect a variable resistor (VRn) of 5 kΩ, 1/20 W to the terminal M on the driver.

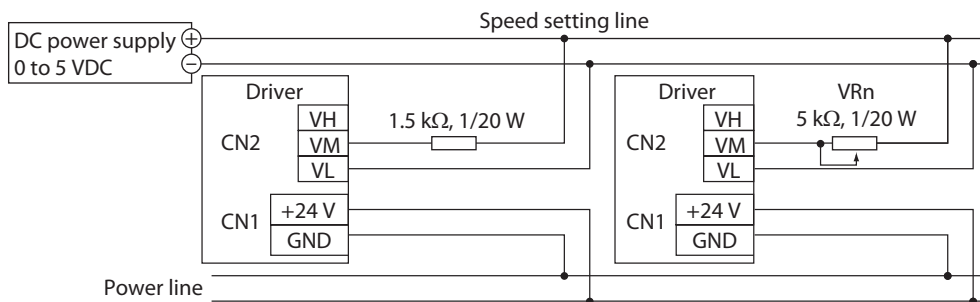

# 8 Maintenance and inspection

---

## 8.1 Inspection

It is recommended that periodic inspections would be conducted for the items listed below after each operation of the motor.

If an abnormal condition is noted, discontinue any use and contact your nearest Oriental Motor sales office.



- Do not conduct the insulation resistance measurement or dielectric strength test with the motor and driver connected. Doing so may cause damage to the product.
- The driver uses semiconductor elements, so be extremely careful when handling them. Static electricity may damage the driver.

### ■ Inspection item

- Check if any of the mounting screws of the motor and gearhead is loose.
- Check if the bearing part (ball bearings) of the motor generates unusual noises.
- Check if the bearing part (ball bearings) or gear meshing part of the gearhead generates unusual noises.
- Check if the output shaft of the motor and gearhead and a load shaft are out of alignment.
- Check if a damage or stress is applied on the cable or the connection part between the cable and driver is loose.
- Check if dust is deposited on the driver.

## 8.2 Warranty

Check on the Oriental Motor Website for the product warranty.

## 8.3 Disposal

Dispose the product correctly in accordance with laws and regulations, or instructions of local governments.

# 9 Troubleshooting

The motor or driver may not operate properly if the rotation speed is wrongly set or the connection is wrong. If the motor cannot operate properly, refer to the contents provided in this chapter and take appropriate action. If the problem persists, contact your nearest Oriental Motor sales office.

**Note** Check the alarm contents when an alarm is generated.

<p><b>The motor does not rotate.</b></p>	<ul style="list-style-type: none"> <li>● The power supply is not connected correctly or it is improper connection.                             <ul style="list-style-type: none"> <li>▷ Check the connection of the power supply.</li> </ul> </li> </ul>
	<ul style="list-style-type: none"> <li>● The operation input signal is not turned ON.                             <ul style="list-style-type: none"> <li>▷ Check if both the START/STOP input and the RUN/BRAKE input are turned ON.</li> </ul> </li> </ul>
	<ul style="list-style-type: none"> <li>● The M0 input is selected wrongly. Or the motor connector is not connected properly.                             <ul style="list-style-type: none"> <li>▷ Check the M0 input. ON: VR1    OFF: External analog setting device</li> </ul> </li> </ul>
	<ul style="list-style-type: none"> <li>● An alarm is present.                             <ul style="list-style-type: none"> <li>▷ Check if an alarm is generated. The PWR/ALM LED blinks in red while an alarm is present. For alarm contents, check the number of times the LED blinks. Refer to p.24, and reset the alarm after removing the cause of the alarm.</li> </ul> </li> </ul>
<ul style="list-style-type: none"> <li>• A time for stopping is long.</li> <li>• The stopping method is wrong.</li> </ul>	<ul style="list-style-type: none"> <li>● The stopping method is wrongly selected.                             <ul style="list-style-type: none"> <li>▷ Check the stopping method. The stop movement when turning the RUN/BRAKE input OFF is different from that when turning the START/STOP input OFF. Refer to p.18 for details.</li> </ul> </li> </ul>
	<ul style="list-style-type: none"> <li>● The deceleration time is too long.                             <ul style="list-style-type: none"> <li>▷ Check the setting of the acceleration time and deceleration time.</li> </ul> </li> </ul>
	<ul style="list-style-type: none"> <li>● Load inertia is too large.                             <ul style="list-style-type: none"> <li>▷ Check by increasing the frictional load or reducing the load inertia.</li> </ul> </li> </ul>
<p><b>The motor rotates in the opposite direction to the specified one.</b></p>	<ul style="list-style-type: none"> <li>● The ON-OFF operation of the FWD/REV input is used wrongly or the FWD/REV input is not connected correctly.                             <ul style="list-style-type: none"> <li>▷ Check the connection and the ON-OFF status of signal.</li> </ul> </li> </ul>
	<ul style="list-style-type: none"> <li>● The gearhead with a reduction ratio which rotation direction is opposite to the motor output shaft is used. (Refer to p.20 for the rotation direction of the gearhead output shaft)                             <ul style="list-style-type: none"> <li>▷ Reverse the ON-OFF operation of the FWD/REV input.</li> </ul> </li> </ul>
	<ul style="list-style-type: none"> <li>● A hollow shaft flat gearhead is used.                             <ul style="list-style-type: none"> <li>▷ The hollow shaft flat gearhead rotates in the opposite direction to the motor when viewed from the front side of the gearhead, and rotates in the same direction to the motor when viewed from the rear side (motor mounting side).</li> </ul> </li> </ul>
<ul style="list-style-type: none"> <li>• The motor movement is not stable.</li> <li>• Motor vibration is too large.</li> </ul>	<ul style="list-style-type: none"> <li>● The motor and gearhead output shaft and a load shaft are out of alignment.                             <ul style="list-style-type: none"> <li>▷ Check the coupling condition of the motor and gearhead output shaft and the load shaft.</li> </ul> </li> </ul>
	<ul style="list-style-type: none"> <li>● The motor output power and the driver output power are not matched.                             <ul style="list-style-type: none"> <li>▷ Check if the motor output power and the driver output power are the same. For the output power, check the nameplates of the motor and driver.</li> </ul> </li> </ul>
	<ul style="list-style-type: none"> <li>● The product is affected by electrical noise.                             <ul style="list-style-type: none"> <li>▷ Check the operation using the motor, driver and a minimum of external equipment required for operation. If an effect of noise has been confirmed, implement the following countermeasures: [Keep away from the noise sources.] [Reconsider the wiring.]</li> </ul> </li> </ul>

# 10 Alarms

This driver has the alarm function to protect from temperature rise, poor connection, error in operation, and others. If an alarm is generated, the ALM-B output will be turned OFF, and simultaneously the motor will stop and the PWR/ALM LED will blink in red.

The generated alarm content can be checked by counting the number of times the LED blinks.

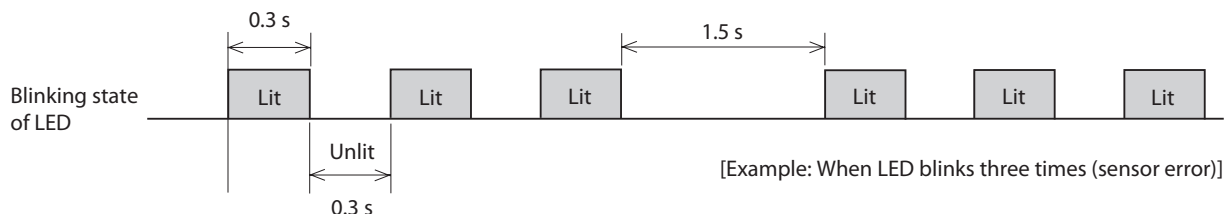

## 10.1 Alarm reset

Before resetting an alarm by one of the following methods, be sure to remove the cause of the alarm and ensure safety.

- Turn the ALM-RST input from ON to OFF. (The alarm will be reset at the OFF edge of the input.)
- Turn on the power again.



- Some alarms cannot be reset other than turning on the power again. Refer to "10.2 Alarm lists" on the next page.
- Continuing the operation without removing the cause of the alarm may cause damage to equipment.
- The driver does not accept the START/STOP input and RUN/BRAKE input until the alarm is reset.
- Perform the ALARM-RESET input after the motor (gearhead) output shaft is stopped completely.

Turn the operation input signal OFF, and remove the cause of the alarm before resetting the alarm.

The alarm reset is disabled while the operation input signal is being ON.

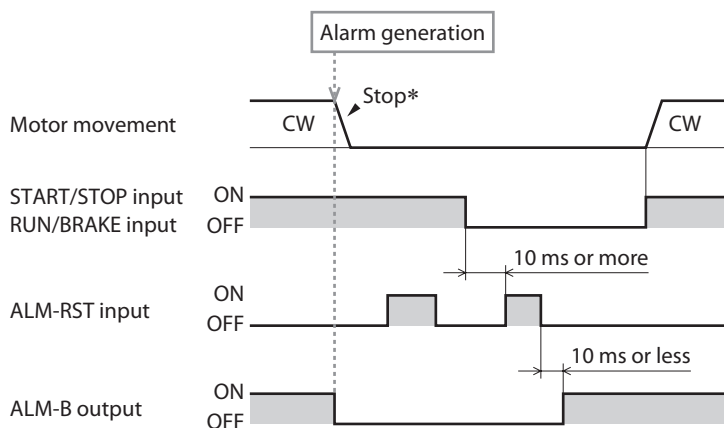

\* If an alarm is generated while the motor rotates, the motor will coast to a stop.

## 10.2 Alarm lists

Number of times PWR/ALM LED blinks	Alarm name	Cause	Remedial action	Reset using the ALM-RST input	
Two times	Overload	A load exceeding the rated torque was applied to the motor for 10 seconds or more.	<ul style="list-style-type: none"> <li>• Decrease a load.</li> <li>• Reconsider operating conditions such as the acceleration time and deceleration time.</li> <li>• If the alarm is generated at a low temperature, warm up.</li> </ul>	Possible	
Three times	Sensor error	The sensor line in the motor cable was disconnected. Or the motor cable was come off.	Check the connection between the driver and motor.		
	Sensor error at power-on	The sensor line in the motor cable was disconnected. Or the driver power supply was turned on in a state where the motor cable was come off.			
Four times	Overvoltage	The internal voltage of the driver exceeded 38 VDC.	<ul style="list-style-type: none"> <li>• Check the power supply voltage.</li> <li>• If the alarm is generated during operation, decrease a load or increase the deceleration time.</li> <li>• If the motor is rotated by external force, reconsider how to use or environment.</li> </ul>		
Five times	Undervoltage	The internal voltage of the driver dropped below 18 VDC.	<ul style="list-style-type: none"> <li>• Check the power supply voltage.</li> <li>• Check the wiring of the power supply cable.</li> </ul>		
Six times	Overspeed	The motor rotation speed was exceeded 5200 r/min.	<ul style="list-style-type: none"> <li>• Decrease a load.</li> <li>• Reconsider operating conditions such as the acceleration time and deceleration time.</li> <li>• If the motor is rotated by external force, reconsider how to use or environment.</li> </ul>		
Seven times	Overcurrent	Excessive current was flown through the driver due to ground fault, etc.	Turn off the power, and check if the product is not damaged before turning on the power again. If the alarm is not cleared, contact your nearest Oriental Motor sales office.		Not possible
Eight times	EEPROM error	The data stored in the driver was damaged.	Turn on the power again. If the alarm is not cleared, contact your nearest Oriental Motor sales office.		
Nine times	Main circuit overheat	The internal temperature of the driver exceeded 85 °C (185 °F).	<ul style="list-style-type: none"> <li>• Reconsider the ambient temperature.</li> <li>• Reconsider the ventilation condition.</li> <li>• Reconsider the operating condition.</li> </ul>		Possible
Lit	CPU error	The CPU is not operated properly.	Turn on the power again. If the alarm is not cleared, contact your nearest Oriental Motor sales office.	Not possible	



# 11 Specifications

## 11.1 Specifications

Values in the rated torque, peak torque, rated rotation speed, and speed control range represent those in a state where the gearhead is not combined. For details about the motor, refer to the operating manual of the motor.

### ■ 15 W

Model	Driver	<b>BLH2D15-K</b>	<b>BLH2D15H-K</b>
	Motor	<b>BLHM015</b>	<b>BLM015HK</b>
Rated output power (Continuous)		15 W	
Power supply input	Rated voltage	24 VDC	
	Permissible voltage range	-10 to +10%	
	Rated input current	0.93 A	0.96 A
	Maximum input current	2.3 A	2.5 A
Rated torque		0.048 N·m (6.8 oz-in)	
Peak torque		0.072 N·m (10.2 oz-in)	
Rated rotation speed		3000 r/min	
Speed control range		100 to 3000 r/min	

### ■ 30 W

Model	Driver	<b>BLH2D30-K</b>	<b>BLH2D30DH-K</b>	<b>BLH2D30H-K</b>
	Motor	<b>BLHM230</b>	<b>BLM030DHK</b>	<b>BLM230HK</b>
Rated output power (Continuous)		30 W		
Power supply input	Rated voltage	24 VDC		
	Permissible voltage range	-10 to +10%		
	Rated input current	1.9 A	1.8 A	
	Maximum input current	4.1 A	4.4 A	3.9 A
Rated torque		0.115 N·m (16.3 oz-in)	0.096 N·m (13.6 oz-in)	0.115 N·m (16.3 oz-in)
Peak torque		0.173 N·m (24 oz-in)	0.144 N·m (20 oz-in)	0.173 N·m (24 oz-in)
Rated rotation speed		2500 r/min	3000 r/min	2500 r/min
Speed control range		100 to 3000 r/min		

### ■ 50 W

Model	Driver	<b>BLH2D50-K</b>	<b>BLH2D50DH-K</b>	<b>BLH2D50H-K</b>
	Motor	<b>BLHM450</b>	<b>BLM250DHK</b>	<b>BLM450HK</b>
Rated output power (Continuous)		50 W		
Power supply input	Rated voltage	24 VDC		
	Permissible voltage range	-10 to +10%		
	Rated input current	2.9 A		
	Maximum input current	5.4 A	5.8 A	5.9 A
Rated torque		0.191 N·m (27 oz-in)		
Peak torque		0.287 N·m (40 oz-in)		
Rated rotation speed		2500 r/min		
Speed control range		100 to 3000 r/min		

## 11.2 General specifications

Operating environment	Ambient temperature	Driver: 0 to +50 °C [+32 to +122 °F] (non-freezing)
	Ambient humidity	85% or less (non-condensing)
	Altitude	Up to 1000 m (3300 ft.) above sea level
	Surrounding atmosphere	No corrosive gas, dust, water or oil. Cannot be used in radioactive materials, magnetic field, vacuum or other special environment. (For details about installation locations, refer to p.8.)
	Vibration	Not subject to continuous vibrations or excessive impact. In conformance with JIS C 60068-2-6 "Sine-wave vibration test method" Frequency range: 10 to 55 Hz Pulsating amplitude: 0.15 mm (0.006 in.) Sweep direction: 3 directions (X, Y, Z) Number of sweeps: 20 times
Storage environment	Ambient temperature	Driver: -25 to +70 °C [-13 to +158 °F] (non-freezing)
	Ambient humidity	85% or less (non-condensing)
Shipping environment	Altitude	Up to 3000 m (10000 ft.) above sea level
	Surrounding atmosphere	No corrosive gas, dust, water or oil. Cannot be used in radioactive materials, magnetic field, vacuum or other special environment.
Degree of protection		IP00

## 11.3 Dimension

Mass: 46 g (1.62 oz.)

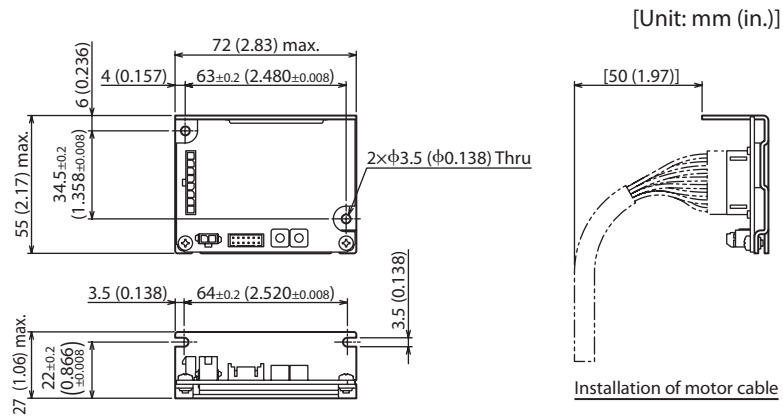

# 12 Regulations and standards

## 12.1 UL Standards and CSA Standards

Some products are recognized by UL under the UL/CSA standards.

Model	Applicable Standards	Certification Body	Standards File No.
BLH2D15-K, BLH2D30-K, BLH2D50-K	UL 62368-1 CSA C22.2 No.62368-1	UL	E208200
BLH2D15H-K, BLH2D30H-K, BLH2D50H-K, BLH2D30DH-K, BLH2D50DH-K	—	—	—

## 12.2 EU Directives

### ■ CE Marking

This product is affixed the CE Marking under the EMC Directive.

#### ● Low Voltage Directives

- This product is not subject to the coverage of the Low Voltage Directive because the input power supply voltage is 24 VDC.
- When conforming the equipment incorporating this product to the Low Voltage Directive, connect the driver power supply input to the DC power supply where the primary and secondary sides are provided with reinforced insulation.
- Install this product inside an enclosure because it is designed and manufactured to be incorporated in equipment.
- Degree of protection for driver: IP00

#### ● EMC Directive

This product has received EMC compliance under the conditions specified in "Example of installation and wiring" on p.16. The final level of conformance of your mechanical equipment to the EMC Directive will vary depending on such factors as the control system equipment used with the motor and driver, configuration of electrical parts, wiring, layout, and hazard level. It therefore must be verified through conducting EMC measures on your mechanical equipment.

Applicable standards

EMI	EN 55011 Group 1 Class A
	EN 61000-6-4
EMS	EN 61000-6-2

**Caution** This equipment is not intended for use in residential environments nor for use on a low-voltage public network supplied in residential premises, and it may not provide adequate protection to radio reception interference in such environments.

## 12.3 Republic of Korea, Radio Waves Act

KC Mark is affixed to this product under the Radio Waves Act, the republic of Korea.

## 12.4 RoHS Directive

The products do not contain the substances exceeding the restriction values of RoHS Directive (2011/65/EU).

- Unauthorized reproduction or copying of all or part of this manual is prohibited.  
If a new copy is required to replace an original manual that has been damaged or lost, please contact your nearest Oriental Motor branch or sales office.
- Oriental Motor shall not be liable whatsoever for any problems relating to industrial property rights arising from use of any information, circuit, equipment or device provided or referenced in this manual.
- Characteristics, specifications and dimensions are subject to change without notice.
- While we make every effort to offer accurate information in the manual, we welcome your input. Should you find unclear descriptions, errors or omissions, please contact the nearest office.
- **Orientalmotor** is a registered trademark or trademark of Oriental Motor Co., Ltd., in Japan and other countries.  
Other product names and company names mentioned in this manual may be registered trademarks or trademarks of their respective companies and are hereby acknowledged. The third-party products mentioned in this manual are recommended products, and references to their names shall not be construed as any form of performance guarantee. Oriental Motor is not liable whatsoever for the performance of these third-party products.

© Copyright ORIENTAL MOTOR CO., LTD. 2018

Published in March 2021

- Please contact your nearest Oriental Motor office for further information.

**ORIENTAL MOTOR U.S.A. CORP.**  
Technical Support Tel:800-468-3982  
8:30am EST to 5:00pm PST (M-F)  
[www.orientalmotor.com](http://www.orientalmotor.com)

**ORIENTAL MOTOR (EUROPA) GmbH**  
Schiessstraße 44, 40549 Düsseldorf, Germany  
Technical Support Tel:00 800/22 55 66 22  
[www.orientalmotor.de](http://www.orientalmotor.de)

**ORIENTAL MOTOR (UK) LTD.**  
Tel:+44-1256347090  
[www.oriental-motor.co.uk](http://www.oriental-motor.co.uk)

**ORIENTAL MOTOR (FRANCE) SARL**  
Tel:+33-1 47 86 97 50  
[www.orientalmotor.fr](http://www.orientalmotor.fr)

**ORIENTAL MOTOR ITALIA s.r.l.**  
Tel:+39-02-93906347  
[www.orientalmotor.it](http://www.orientalmotor.it)

**ORIENTAL MOTOR ASIA PACIFIC PTE. LTD.**  
Singapore  
Tel:1800-842-0280  
[www.orientalmotor.com.sg](http://www.orientalmotor.com.sg)

**ORIENTAL MOTOR (MALAYSIA) SDN. BHD.**  
Tel:1800-806-161  
[www.orientalmotor.com.my](http://www.orientalmotor.com.my)

**ORIENTAL MOTOR (THAILAND) CO., LTD.**  
Tel:1800-888-881  
[www.orientalmotor.co.th](http://www.orientalmotor.co.th)

**ORIENTAL MOTOR (INDIA) PVT. LTD.**  
Tel:1800-120-1995 (For English)  
1800-121-4149 (For Hindi)  
[www.orientalmotor.co.in](http://www.orientalmotor.co.in)

**TAIWAN ORIENTAL MOTOR CO., LTD.**  
Tel:0800-060708  
[www.orientalmotor.com.tw](http://www.orientalmotor.com.tw)

**SHANGHAI ORIENTAL MOTOR CO., LTD.**  
Tel:400-820-6516  
[www.orientalmotor.com.cn](http://www.orientalmotor.com.cn)

**INA ORIENTAL MOTOR CO., LTD.**  
Korea  
Tel:080-777-2042  
[www.inaom.co.kr](http://www.inaom.co.kr)

**ORIENTAL MOTOR CO., LTD.**  
4-8-1 Higashiueno, Taito-ku, Tokyo  
110-8536 Japan  
Tel:+81-3-6744-0361  
[www.orientalmotor.co.jp](http://www.orientalmotor.co.jp)