

**PROTECT
YOUR TRANSMISSION
SYSTEM**

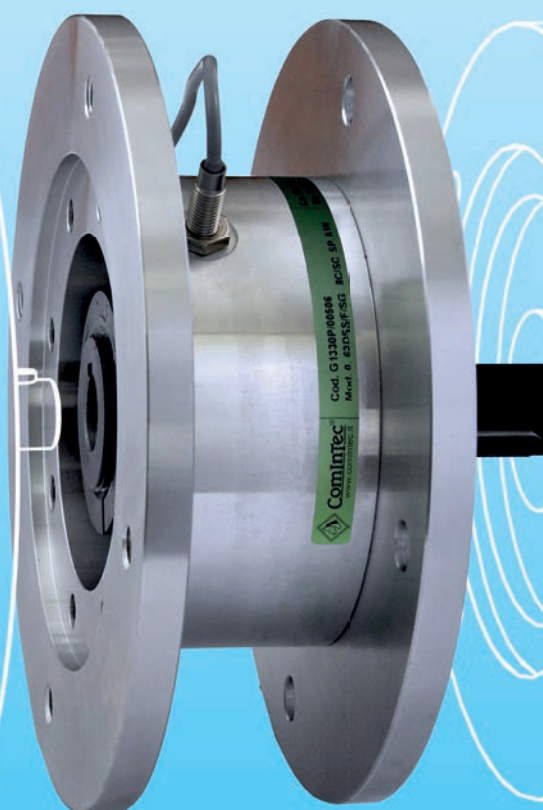

ComIntec[®]
Safety in Power Transmission



- Overload protection
- Easy assembly and setting
- Maintenance free
- IP67 level of water ingress protection
- High corrosion resistance
- Free rotation version according to ATEX conformity

TORQUE LIMITERS FOR GEARBOXES

Up to 1300 Nm

.../PR-V



DSS/F/SG/PR-V and DSS/SG/RF/PR-V - backlash free ball model for gearboxes (input shaft):

- Balls solution, torsional backlash free, maintenance free
- Instant disengagement between the driver and the driven component when the calibration torque is exceeded
- Available with 360° automatic (DSS/F/SG/PR-V) or manual (DSS/SG/RF/PR-V) re-engagement
- Solution complete with zinc-plated STEEL connection flange for IEC and **NEMA** motors
- IP67 level of protection from external agents
- Integrated inductive sensor for monitoring overloads
- Available pre-calibrated and ready for use
- Free rotation backlash free balls model according to **ATEX** 2014/34/UE conformity II 2G Ex h il B T5 Gb -15°C ≤ Ta ≤ +80°C
- Anticorrosive surface treatment option for specific requirements

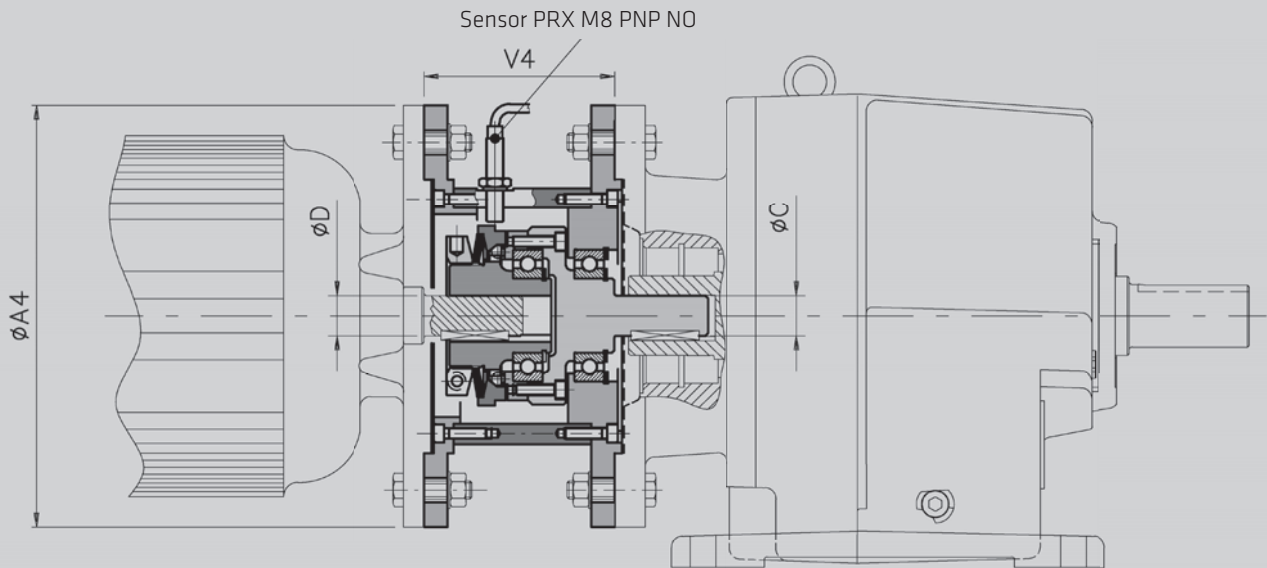

		Std. backlash free model DSS/F/SG/PR-V						Free rotation backlash free model DSS/SG/RF/PR-V						
Motor IEC*	Size T.L.	torque [Nm]	D H7 / C h7	A4	V4	weight [Kg]	max speed	torque [Nm]	D H7 / C h7	A4	V4	weight [Kg]	max speed	
63	00,47	3-23	11	140	52,5	3,5	4000							
71			14	160	54,5	4,2								
80	00,63	5-50	19	200	78	8	4000	5-50	19	200	86	8,5	4000	
90	1,80	9-100	24	200	90	9	3000	9-100	24	200	99	12	4000	
100	2,96	20-200	28	250	110	17	2500	20-200	28	250	121	19,5	3000	
112														
Δ 132	3,116	35-415	38	300	110	24	2000	50-400	38	300	140	29,5	3000	
Δ 160	4,138	75-720	42	350	126	33,5	1850**	70-720	42	350	148	36	3000	
Δ 180			48			36		48	38					
Δ 200	5,172							120-1300		55	400	192	70	3000
Δ 225										60	450		80	
Δ 250										65	550	194	110	
Δ 280														

Δ On request * IEC Motor Flange B5 ** For calibrations over 350 Nm the maximum speed is reduced to 1200 Rpm

Technical data:



PRX: M8 PNP NO inductive proximity sensor

- INOX IP67 stainless steel housing
- Electrical contact 7 ± 30 VCC
- Working frequency 4KHz
- Operating temperature from -20°C ÷ +70°C.
- Output: NPN (N.O. - N.C.); PNP (N.O. - N.C.).
- Cable length: 2 meter (3x0,2)



PRX-EX - ATEX proximity induced sensor

- Housing in nickel-plated brass
- Voltage 8.2 Vdc (1 KOhm)
- Operating temperature from -25° ÷ +60°C
- IP67 protection
- Cable length: 3 meters (2x0,25)

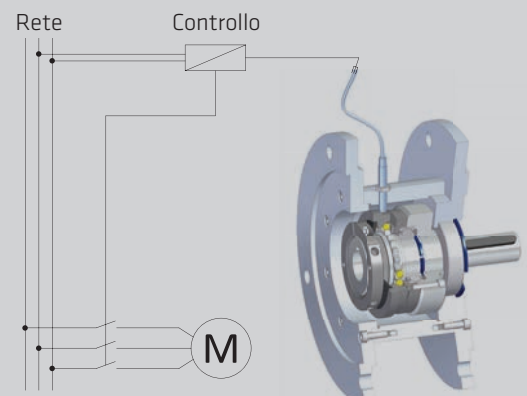

COMINTEC PR-V GEARBOX TORQUE LIMITERS PROTECT YOUR MOST EXPENSIVE SYSTEM COMPONENTS FROM TORQUE OVERLOADS.

Applications

- Food & Beverage equipment
- Wastewater treatment
- Packaging equipment

How it works

- Mounts directly to the motor and gearbox
- Suited for flange motors and gearbox
- Instant disengagement

Construction

- Housing: Standard Zinc plated steel
- Torque limiter: machined steel
- Sensor: inductive proximity integrated

Technical



- Torque setting is adjustable and easy to change
- Automatic (DSS/F/SG/PR-V) or manual (DSS/SG/RF/PR-V) reset
- ATEX conformity for DSS/SG/RF/PR-V

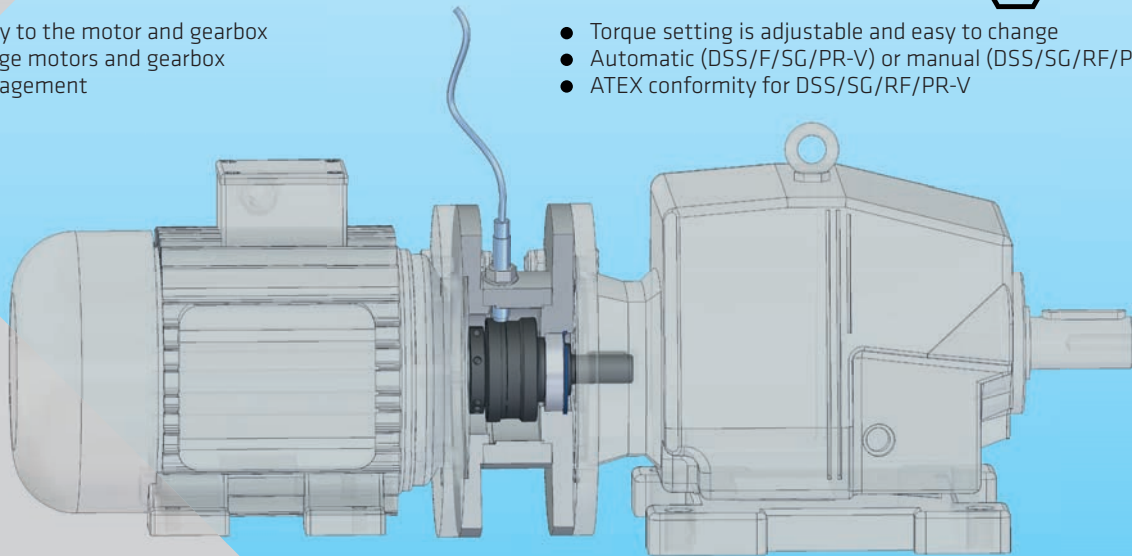

	ComInTec PR-V model	High torque ball detent	Friction style	Electric sensing
Disengagement	+ Instant	+ Instant	- Friction	- Delayed
Installation	+ Simple interface with motor and gearbox	+ Output of gearbox	+ Simple interface	- Integrated into electronic circuits
Dimension	+ Compact design	- Larger size due to high torque	+ Compact design	+ Small physical size
Maintenance	+ None required	+ None required	- Replace worn components	- Frequent checking of calibration
Price	€€€	€€€€€	€€	€

+ technical value

- technical value

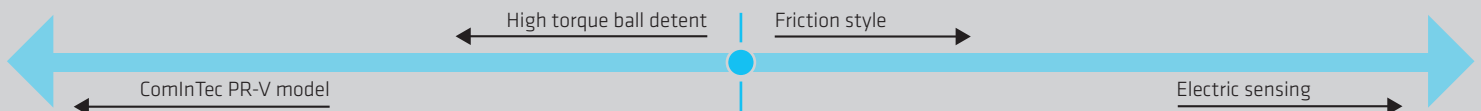

COMINTEC PR-V MODEL OFFERS EASE OF DESIGN, INSTALLATION AND THE SAME PROTECTION OF THE HIGH TORQUE BALL DETENT DEVICES AT A BETTER PRICE POINT.

DF/TAC/PR-V - Friction model for gearboxes (input shaft):

- Friction solution, compact and economical
- The drive component slips when the calibration torque is exceeded without fully disengaging the drive transmission
- Available with friction rings with performance specifications designed to suit the application
- Solution including aluminium connection flanges for IEC motors
- Integrated inductive sensor option for monitoring overloads
- Available pre-calibrated and ready for use
- Anticorrosion surface treatment option for specific requirements

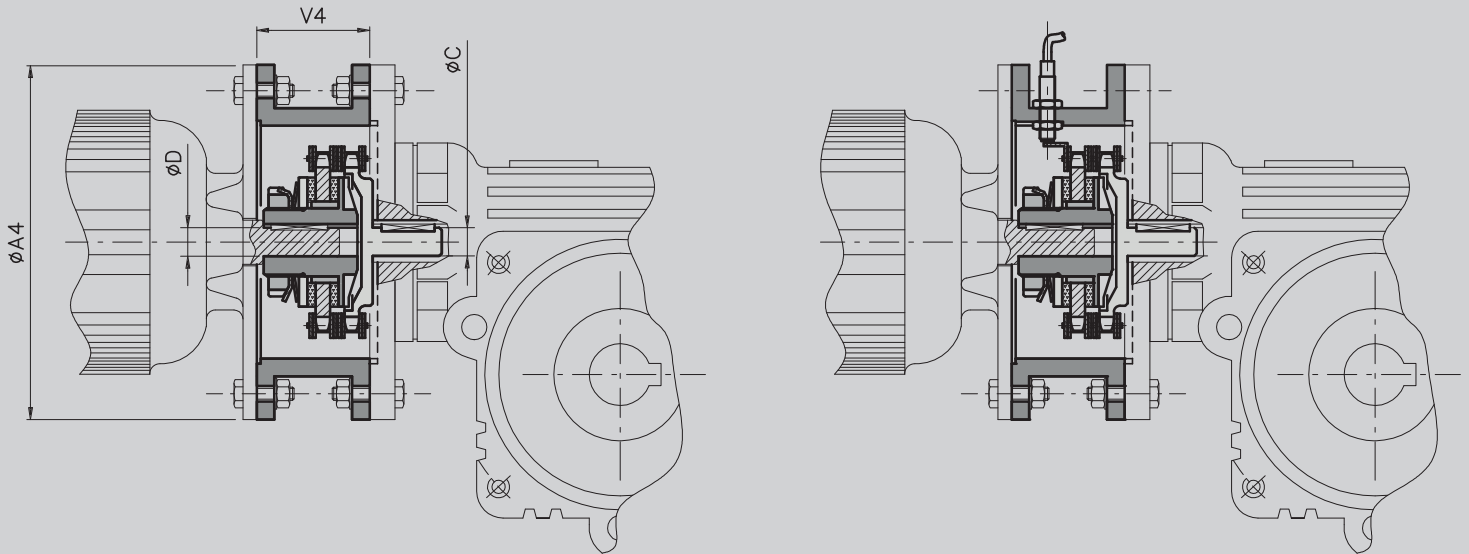

Motor IEC*	Size T.L	torque [Nm]	model DF/TAC/PR-V				max speed [Rpm]
			DH7/Ch7	A4	V4	weight [Kg]	
63	00.38	1-34	11	140	43	1.1	5000
71			14	160	43	1.2	
80	0.50	2-100	19	200	45.5	2	3800
90			24	200	55.5	2.7	
100	1.70	6-210	28	250	66	4.8	2800
112			38	300	83.5	9	
Δ 160	3.115	65-950	42	350	121	16	1800
Δ 180			48			16.2	
Δ 200	4.140	180-1200	55	400	122	27	1500

Model **DF/TAC/PR-V** complete with spacer to be assembled between the motor and gearbox with **PRX** insetion and sensor.

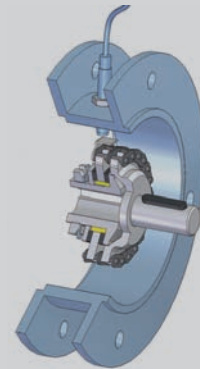

Δ On request

* IEC Motor Flange B5



ComInTec S.r.l.

Via Dell'artigiano, 9
40055 Villanova di Castenaso (BO) - Italy
Tel. +39 051 780216 - Fax +39 051 782256
info@comintec.it - www.comintec.com

MADE IN ITALY



05 2021



ATTIVITÀ COFINANZIATA DALLE CAMERE
DI COMMERCIO DELL'EMILIA ROMAGNA

