

# Series GMPD

## Motor type 406 182

Design Data	
Commutation	Brushed
Direction of rotation	Bi-directional
Bearing type	A:Sleeve - B:Sleeve

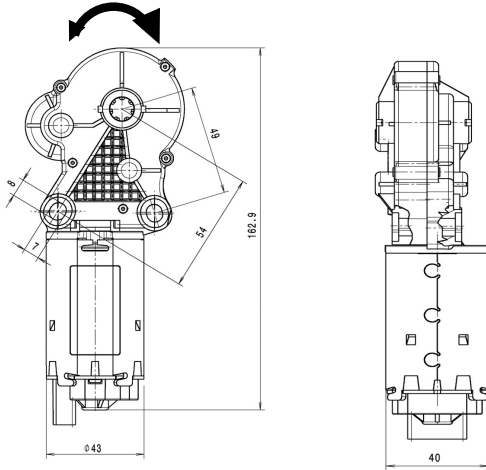

### Motor picture



Performance data		
Rated voltage [V]	$U_N$	12
Nominal torque [Nm]	$M_N$	2.00
No-load speed [ $\text{min}^{-1}$ ]	$n_0$	22.0
Nominal power [W]	$P_N$	4.10
Nominal current [A]	$I_N$	4.0
Nominal force [kN]	$F_N$	0.00
Duty cycle		s3

Sensor data	
Pulses	0
Output channels	0

Other data	
Gear ratio	210/1
Gear wheel material	plastic
Suppression components	7,5 $\mu$ H, 1nF
Enclosure class	IP40
Weight [kg]	0.440

Remarks:

### Characteristic curves

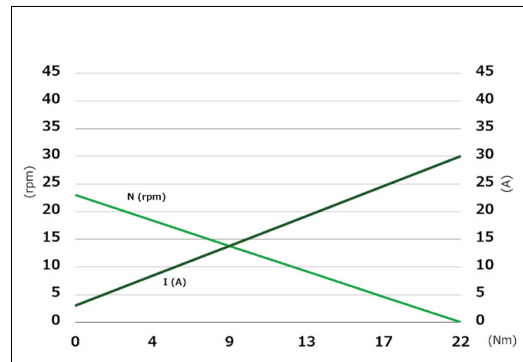

### Output shaft drawing (W),

#### W 270

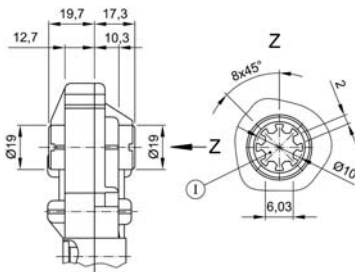

I through profile

I Terminal 1  
II Terminal 5

### Connector layout (K)

#### K 220

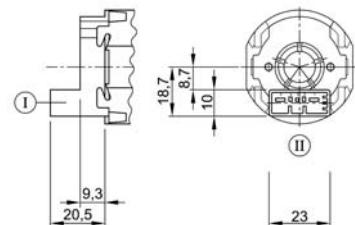

Connector TYCO C-208-15621 (Z) mating with:  
Connector housing 1379217-3 & cover  
1379218-2  
[www.tycoelectronics.com](http://www.tycoelectronics.com)