

Leveling pads
Easy Clean Series
with thread cover

Movex[®]

PRODUCT PRESENTATION

Easy Clean

Ø75-Ø100-Ø125-Ø150-Ø180

Leveling pads

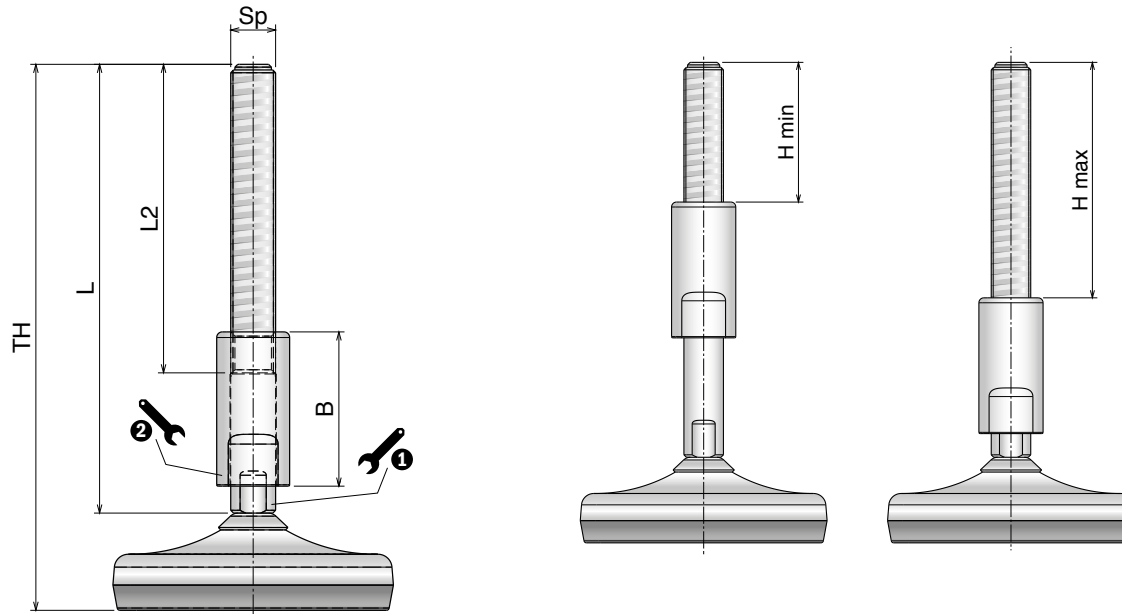

Adjustment range

	H min	H max
L: 160 / B: 55	56,6	95,4
L: 210 / B: 85	45,6	114,5

Accessories / Stainless steel nuts

Part	Article-Nr.	Spindle
998	99804	M16
998	99805	M20
998	99806	M24



Material:

Base plate, spindle and washer: Stainless steel
+ NBR Vulcanized rubber

Base diameter 75 mm

Part	Article-Nr.	Sp	TH	L	L2	B	1	2
987	98701	M16	190	160	110	55	13	19
987	98702		240	210	130	85	13	19
987	98703	M20	190	160	110	55	16	24
987	98704		240	210	130	85	16	24
987	98705	M24	190	160	110	55	19	27
987	98706		240	210	130	85	19	27

Base diameter 100 mm

Part	Article-Nr.	Sp	TH	L	L2	B	1	2
988	98801	M16	195	160	110	55	13	19
988	98802		245	210	130	85	13	19
988	98803	M20	195	160	110	55	16	24
988	98804		245	210	130	85	16	24
988	98805	M24	195	160	110	55	19	27
988	98806		245	210	130	85	19	27

Base diameter 125 mm

Part	Article-Nr.	Sp	TH	L	L2	B	1	2
989	98901	M16	195	160	110	55	13	19
989	98902		245	210	130	85	13	19
989	98903	M20	195	160	110	55	16	24
989	98904		245	210	130	85	16	24
989	98905	M24	195	160	110	55	19	27
989	98906		245	210	130	85	19	27

Spindle: ■ M20 Stock item ■ M16/M24 On request

Easy Clean

Ø75-Ø100-Ø125-Ø150-Ø180

Leveling pads

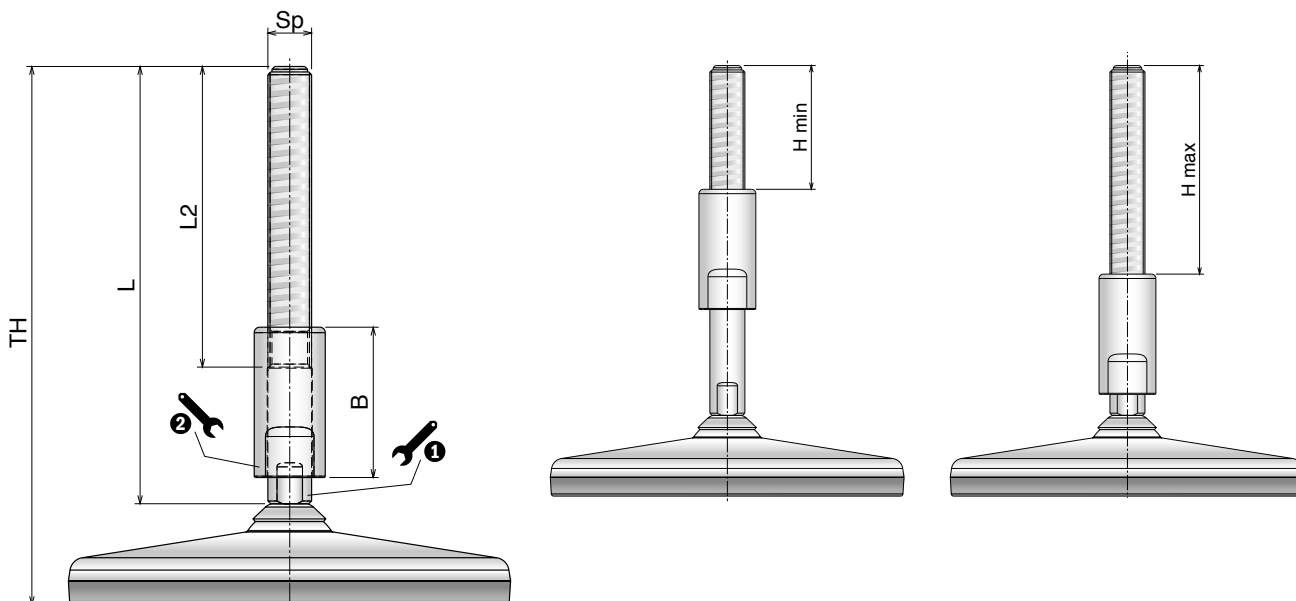

Adjustment range

	H min	H max
L: 160 / B: 55	56,6	95,4
L: 210 / B: 85	45,6	114,5

Accessories / Stainless steel nuts

Part	Article-Nr.	Spindle
998	99804	M16
998	99805	M20
998	99806	M24



Material:

Base plate, spindle and washer: Stainless steel
+ NBR Vulcanized rubber

Base diameter 150 mm

Part	Article-Nr.	Sp	TH	L	L2	B	1	2
990	99001	M16	195	160	110	55	13	19
990	99002		245	210	130	85	13	19
990	99003	M20	195	160	110	55	16	24
990	99004		245	210	130	85	16	24
990	99005	M24	195	160	110	55	19	27
990	99006		245	210	130	85	19	27

Base diameter 180 mm

Part	Article-Nr.	Sp	TH	L	L2	B	1	2
991	99101	M16	195	160	110	55	13	19
991	99102		245	210	130	85	13	19
991	99103	M20	195	160	110	55	16	24
991	99104		245	210	130	85	16	24
991	99105	M24	195	160	110	55	19	27
991	99106		245	210	130	85	19	27

Spindle: ■ M20 Stock item ■ M16/M24 On request

Movex[®]

Easy Clean

Ø75-Ø100

Leveling pads with fixing holes

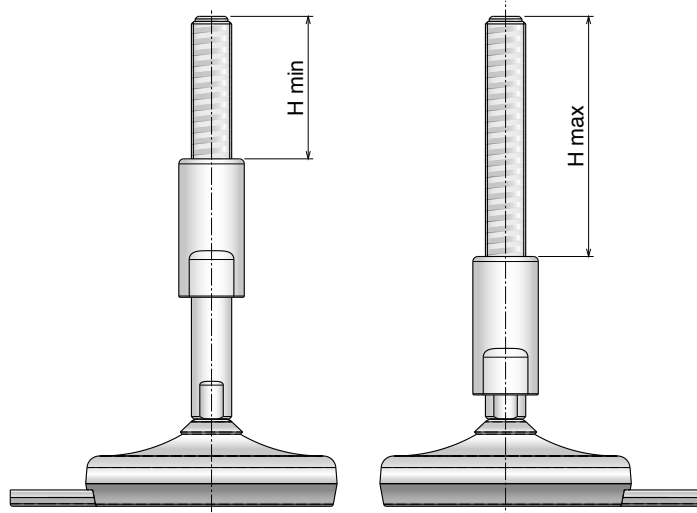
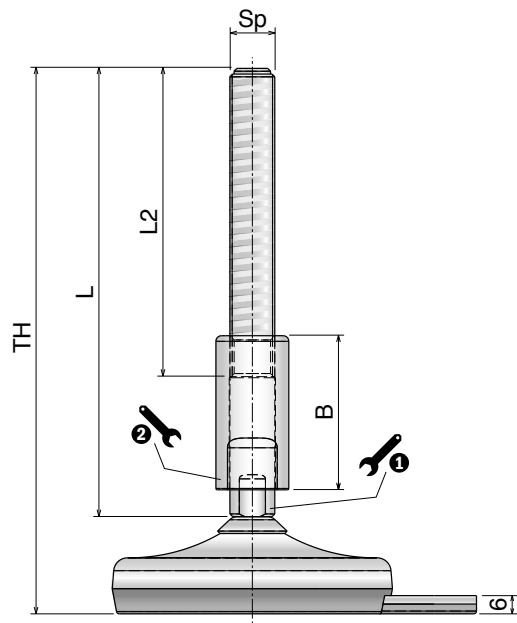

Adjustment range

	H min	H max
L: 160 / B: 55	56,6	95,4
L: 210 / B: 85	45,6	114,5

Accessories / Stainless steel nuts

Part	Article-Nr.	Spindle
998	99804	M16
998	99805	M20
998	99806	M24



Material:

Base plate, spindle and washer: Stainless steel
+ NBR Vulcanized rubber

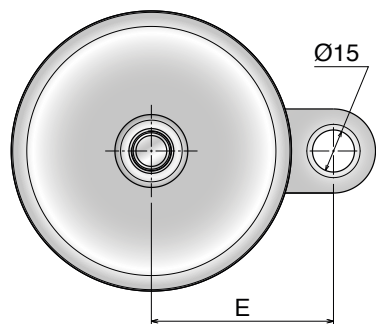

Base diameter 75 mm

Part	Article-Nr.	Sp	TH	L	L2	B	E	1	2
992	99201	M16	190	160	110	55	52,5	13	19
992	99202		240	210	130	85	52,5	13	19
992	99203	M20	190	160	110	55	52,5	16	24
992	99204		240	210	130	85	52,5	16	24
992	99205	M24	190	160	110	55	52,5	19	27
992	99206		240	210	130	85	52,5	19	27

Base diameter 100 mm

Part	Article-Nr.	Sp	TH	L	L2	B	E	1	2
993	99301	M16	195	160	110	55	65	13	19
993	99302		245	210	130	85	65	13	19
993	99303	M20	195	160	110	55	65	16	24
993	99304		245	210	130	85	65	16	24
993	99305	M24	195	160	110	55	65	19	27
993	99306		245	210	130	85	65	19	27

Spindle: ■ M20 Stock item ■ M16/M24 On request

Movex[®]

www.movexii.com

PRODUCT PRESENTATION