

# Actuator

## FD10

FD10 is a small and quiet actuator. It allows small fitting dimensions, which makes FD10 an ideal solution for recliner and bed as neck actuator. It is able to connect with hand control and power supply to make up a simple system without control box.

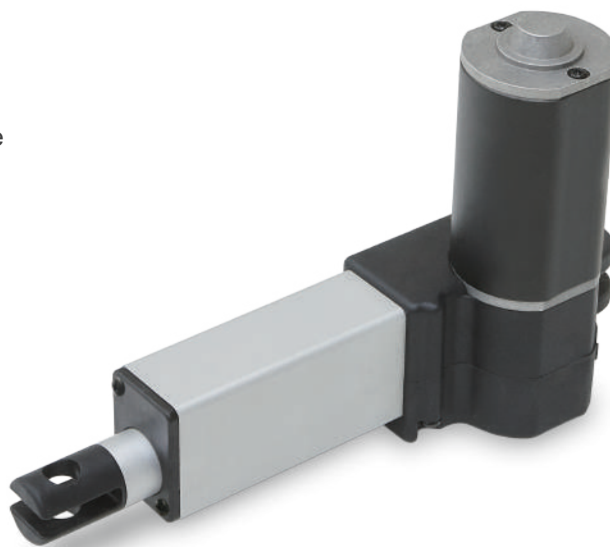

### Features and Options

---

**Main applications:** Furniture

**Standard features:**

- Input voltage: 24V DC
- Max. load: 1000N (Push) / 500N (Pull)
- Typical speed at no load: 15.1 mm/sec
- Stroke: 50 ~ 300 mm
- Noise level:  $\leq 50$ dB
- IP Protection level: IP42 (static, non-action)
- Color: Black
- Preset limit switches
- Duty cycle: 10%, max. 2 min. continuous operation in 18 min.
- Operating ambient temperature: -20°C ~ +65°C

**Options:**

- Positioning signal feedback with Hall effect sensor x 2
- Mechanical push only extension tube
- PTC thermistor for thermal protection

## Performance Data

Model	Push Max. (N)	Pull Max. (N)	*Typical Speed (mm/s)		*Typical Current (A) @ 24V	
			No load	Full load	No load	Full load
FD10-24SF4-XXX.XXX-XXXXX0X	1000	500	8.4	5.5	0.5	1.5
FD10-24SF6-XXX.XXX-XXXXX0X	1000	500	11.5	6.2	0.5	1.7
FD10-24SF8-XXX.XXX-XXXXX0X	500	500	15.1	9.8	0.5	1.3

Speed vs. Load

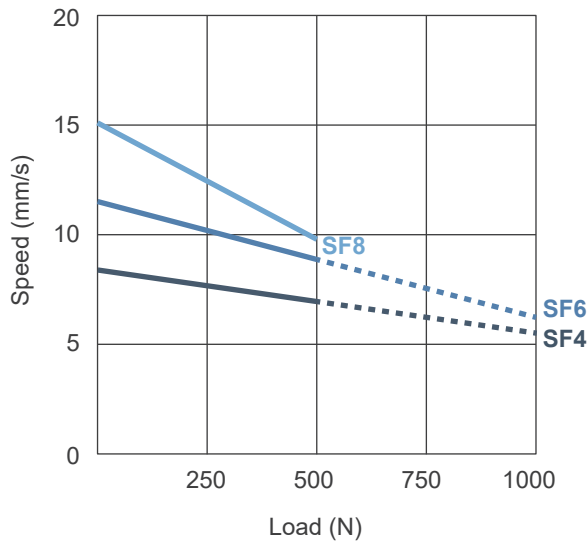

Current vs. Load

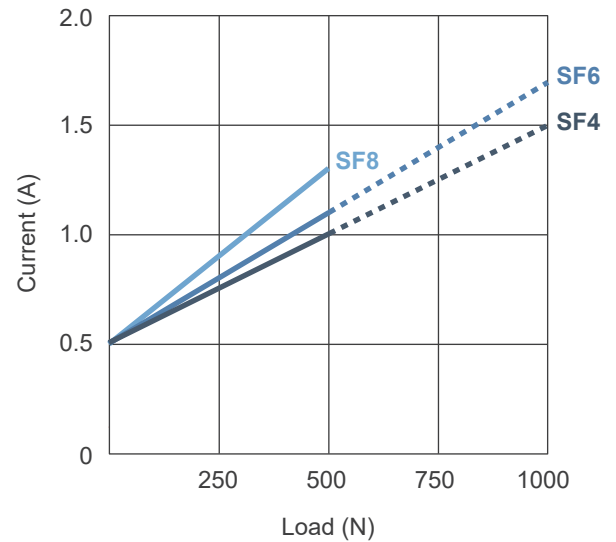

— Push / Pull Load

- - - - Push Load

### Remarks:

- \* The typical speed or typical current means the average value neither upper limit nor lower limit. The performance curves are made with typical values.

# Dimensions

Unit: mm

Front connector code	Stroke (S)		
	$\leq 200\text{mm}$	201~250mm	251~300mm
2	$A \geq S+120\text{mm} (\pm 3\text{mm})$	$A \geq S+130\text{mm} (\pm 3\text{mm})$	$A \geq S+140\text{mm} (\pm 3\text{mm})$
3, 6	$A \geq S+135\text{mm} (\pm 3\text{mm})$	$A \geq S+145\text{mm} (\pm 3\text{mm})$	$A \geq S+155\text{mm} (\pm 3\text{mm})$

Available stroke (S) range = 50 ~ 300mm

Extended length (B) = S + A; Retracted length (A)

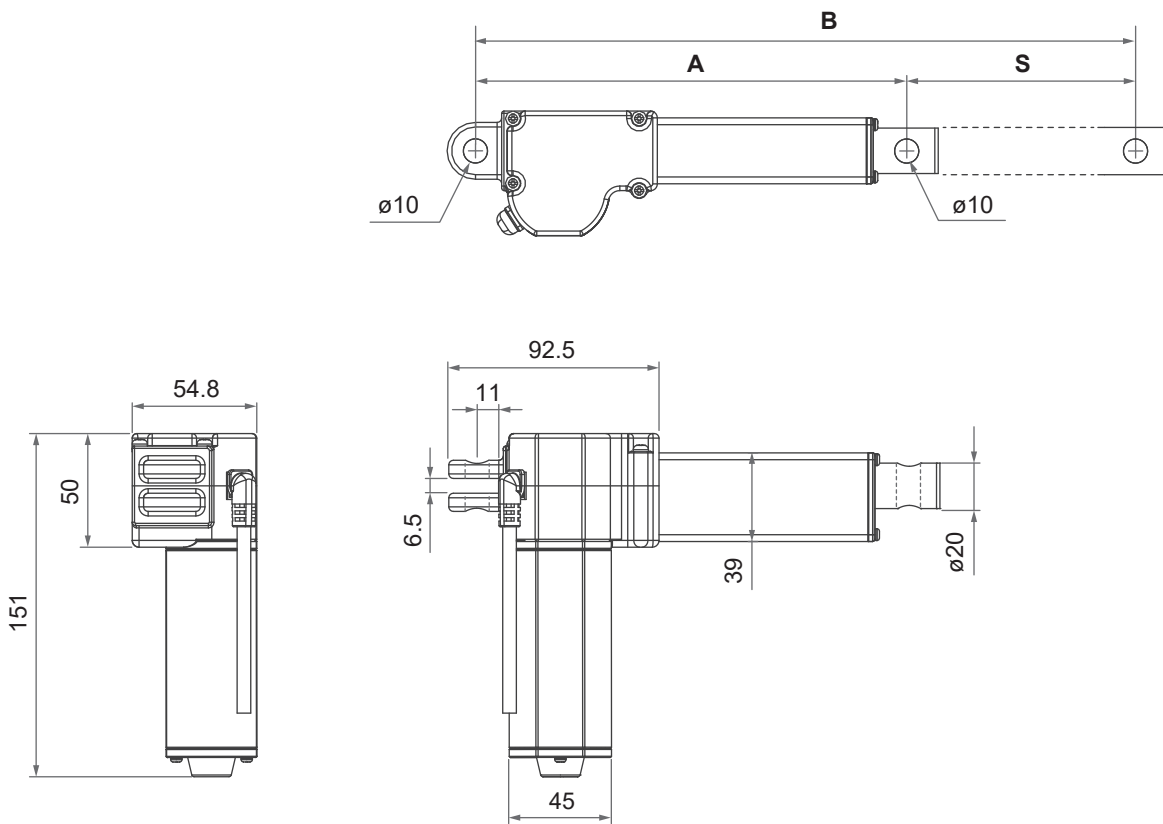

**Remarks:** As an example in  $0^\circ$  orientation for rear connector.

● Front connector

2: Drilled hole

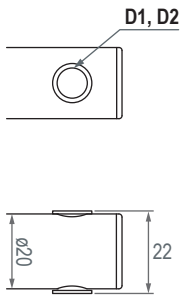

3: Metal slot

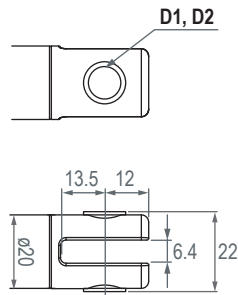

6: Plastic slot

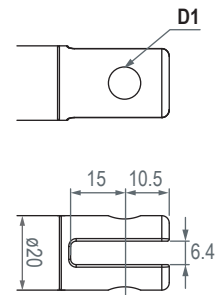

● Pivot orientation of rear connector

4: Plastic, 0°

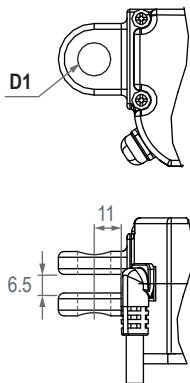

Front connector code	Diameter of pivot without bushing (D1)	Diameter of pivot with bushing (D2)
2	ø8, ø10	ø8
3	ø8, ø10	ø8
6	ø8, ø10	N/A
Rear connector code	Diameter of pivot without bushing (D1)	Diameter of pivot with bushing (D2)
4	ø10	N/A

## Compatibility

Product	Model	FD10 spec
<b>Control box</b>	T-control, CS1, CS2, CB3T, CB4M, CBT2	- Without positioning feedback - With Moteck F-type 4-pin DIN plug
	CF11H, CF12H	- Without positioning feedback - With MOTECK L3-type minifit 6-pin plug
	CB3T-SY, CB4M-S, CB4M-B	- With dual Hall effect sensors for positioning - With Moteck F-type 6-pin DIN plug
	CF11S, CF12S	- With dual Hall effect sensors for positioning - With MOTECK L3-type minifit 6-pin plug
	TX2A	- With Moteck direct-cut power cable DL1
<b>Hand control</b>	Depend on control box	- Powered by control box
	HB, TPSL, H2G, HZ02, HZ03, HZ04, HZ05, HZ06	- With Moteck direct-cut power cable DL1*
<b>Accessory</b>	Power adapter: TSW1, TSW4, DPA-87-2930-C8, DPA-87-2930-C6 (Originally TSW3)	- With Moteck direct-cut power cable DL1

### Remarks:

\* The actuator is connected to the hand control through the DL1 cable directly, no control box.

# Cable Plug

## A. Connecting control devices that provide power

- Without positioning feedback

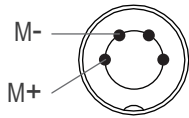

F-type 4-pin DIN plug

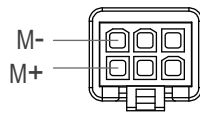

L3-type Minifit 6-pin plug



F-type plug

- Positioning feedback with dual Hall effect sensors

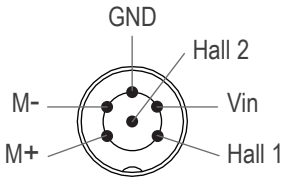

F-type 6-pin DIN plug

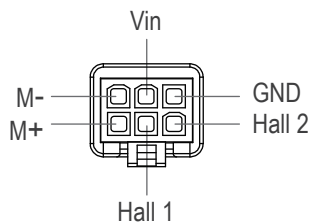

L3-type Minifit 6-pin plug



L3-type plug

**\*Note: Pin definition**

	Definition	Descriptions								
Power	M+	Connect M+ to "Vdc +" & M- to "Vdc -" of DC power to extend the actuator. Switch the polarity of DC input to retract it.								
	M-									
Signal	Vin	Voltage input range: 5 ~ 20V								
	Hall 1 output	High= Input - 1.2V (±0.6V) Low= GND Hall signal data: <div style="display: flex; justify-content: space-around;"> <div style="text-align: center;"> <p>Actuator extends</p> </div> <div style="text-align: center;"> <p>Actuator retracts</p> </div> </div>								
	Hall 2 output	Hall effect sensor resolution: <table border="1" style="width: 100%; border-collapse: collapse;"> <thead> <tr> <th>Model</th> <th>Resolution (pulses/mm)</th> </tr> </thead> <tbody> <tr> <td>FD10-24SF4-XXX.XXX-XXXHX0X</td> <td>7.00</td> </tr> <tr> <td>FD10-24SF6-XXX.XXX-XXXHX0X</td> <td>4.66</td> </tr> <tr> <td>FD10-24SF8-XXX.XXX-XXXHX0X</td> <td>3.50</td> </tr> </tbody> </table>	Model	Resolution (pulses/mm)	FD10-24SF4-XXX.XXX-XXXHX0X	7.00	FD10-24SF6-XXX.XXX-XXXHX0X	4.66	FD10-24SF8-XXX.XXX-XXXHX0X	3.50
	Model	Resolution (pulses/mm)								
FD10-24SF4-XXX.XXX-XXXHX0X	7.00									
FD10-24SF6-XXX.XXX-XXXHX0X	4.66									
FD10-24SF8-XXX.XXX-XXXHX0X	3.50									
GND										

## B. Connecting control devices that DO NOT provide power

### 1. Cable solution

- With direct-cut power cable DL1

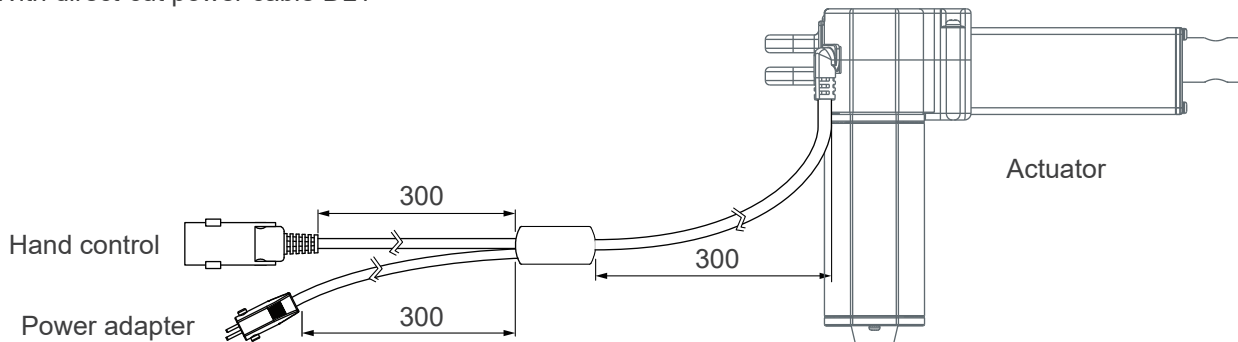

### 2. Hand control connector: Moteck U-type DIN 5-pin female connector

- 1 drive

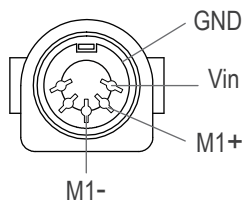

**Note:** Connect M1+ to "Vdc +" & M1- to "Vdc -" of DC power to extend the M1 actuator.  
Switch the polarity of DC input to retract it.



U-type  
female connector

### 3. Power connector: Moteck S-type DIN 41529 2-pin male plug

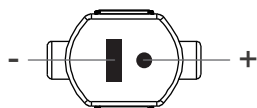

S-type  
male plug

## Wiring with Flying Leads

### Without positioning feedback

	Wire color	Definition	Comments
Power wires	White	DC power	Connect white wire to "Vdc +" & black wire to "Vdc -" of DC power to extend the actuator. Switch the polarity of DC input to retract it.
	Black		

### With single Hall effect sensor for positioning

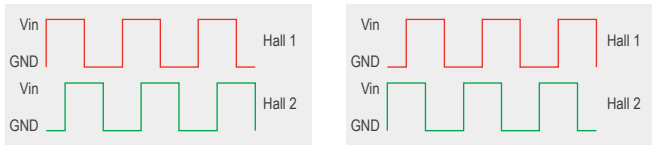
	Wire color	Definition	Comments							
Power wires	Blue	DC power	Connect blue wire to "Vdc +" & Brown wire to "Vdc -" of DC power to extend the actuator. Switch the polarity of DC input to retract it.							
	Brown									
Signal wires	Black	GND								
	Yellow	Vin	Voltage input range: 5 ~ 20V							
	Red	Hall 1 output	<p>High= Input - 1.2V (<math>\pm 0.6V</math>)                      Low= GND                      Hall signal data:</p>  <p style="text-align: center;">Actuator extends                      Actuator retracts</p>							
	Green	Hall 2 output	<p>Hall effect sensor resolution:</p> <table border="1" style="width: 100%; border-collapse: collapse;"> <thead> <tr> <th>Model No.</th> <th>Resolution (pulses/mm)</th> </tr> </thead> <tbody> <tr> <td>FD10-24SF4-XXX.XXX-XXXHX0X</td> <td>7.00</td> </tr> <tr> <td>FD10-24SF6-XXX.XXX-XXXHX0X</td> <td>4.66</td> </tr> <tr> <td>FD10-24SF8-XXX.XXX-XXXHX0X</td> <td>3.50</td> </tr> </tbody> </table>	Model No.	Resolution (pulses/mm)	FD10-24SF4-XXX.XXX-XXXHX0X	7.00	FD10-24SF6-XXX.XXX-XXXHX0X	4.66	FD10-24SF8-XXX.XXX-XXXHX0X
Model No.	Resolution (pulses/mm)									
FD10-24SF4-XXX.XXX-XXXHX0X	7.00									
FD10-24SF6-XXX.XXX-XXXHX0X	4.66									
FD10-24SF8-XXX.XXX-XXXHX0X	3.50									



## Ordering Key

	<b>FD10 - 24 S F8 - 160 . 210 - 6 4 0 H 1 0 A</b>
<b>Input voltage</b>	<b>24:</b> 24V DC
<b>Motor power</b>	<b>S:</b> Short motor
<b>Motor and spindle type</b>	<b>F4:</b> 3500rpm / 4mm pitch <b>F6:</b> 3500rpm / 6mm pitch <b>F8:</b> 3500rpm / 8mm pitch (Refer to page 2)
<b>Retracted length</b>	<b>XXX</b> (Refer to page 3)
<b>Extended length</b>	<b>XXX</b> (Refer to page 3)
<b>Front connector</b>	<b>2:</b> Drilled hole <b>3:</b> Metal <b>6:</b> Plastic (Refer to page 4)
<b>Rear connector</b>	<b>4:</b> Plastic (Refer to page 4)
<b>Pivot orientation of rear connector</b>	<b>0:</b> 0° (Refer to page 4)
<b>Positioning feedback</b>	<b>0:</b> None <b>H:</b> Hall effect sensor x 2
<b>Option</b>	<b>0:</b> None <b>1:</b> Push only extension tube <b>2:</b> PTC thermal protection <b>3:</b> Push only + PTC thermal protection
<b>Reserved</b>	<b>0:</b> No meaning
<b>Cable</b>	<b>0:</b> 300 mm straight <b>1:</b> 1000 mm straight <b>2:</b> 450 mm with 300 mm coiled <b>A:</b> Direct-Cut cable DL1, without control box (Refer to page 7)

### Terms of Use

The user is responsible for application suitability of Moteck products. As ongoing improvement process continues, products listed on the Moteck website are subject to change without prior notice. Moteck reserves the right to terminate the sales or remove any product displayed on the website, or listed in its catalogues.