



# Motor Series **MTS4b**



## Stepper Motor 15°

### Technical Data

Steps per revolution		24		
Winding Type		bipolar		
Rated Voltage	V	6	12	24
Resistance per winding	Ω	9.5	61	251
Winding Type		unipolar		
Rated Voltage	V	6	12	24
Resistance per winding	Ω	15	61	251
Winding temperature	°C	105 max.		
Holding torque	gm-cm	450 (MTS4b)	320 (MTSU4b)	
Axial Force	gm	300		
Lateral Force	gm	600		
Rotor inertia	gmcm <sup>2</sup>	13		

### Drawing

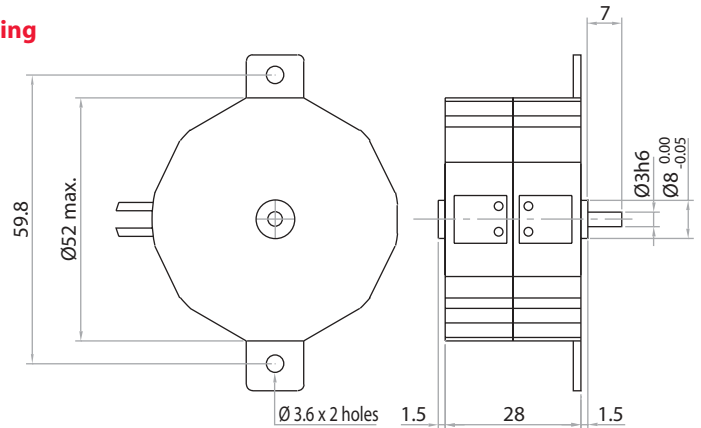

### Ordering Data (eg.)

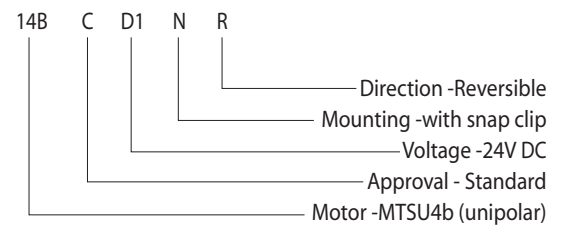

### Torque Graphs

