

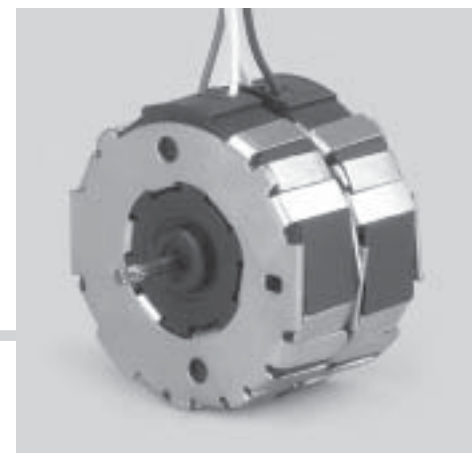

Motor Series **MTS3b**



Stepper Motor 15°

Technical Data

Steps per revolution		24			
Winding Type		bipolar			
Rated Voltage	V	3	6	12	24
Resistance per winding	Ω	11.5	18.5	100	460
Winding Type		unipolar			
Rated Voltage	V	3	6	12	24
Resistance per winding	Ω	12	28.5	120	500
Winding temperature	$^{\circ}\text{C}$	105 max.			
Holding torque	gm-cm	120 (MTSB3b)	100 (MTSU3b)		
Axial Force	gm	100			
Lateral Force	gm	300			
Rotor inertia	gcm ²	2.9			

Drawing

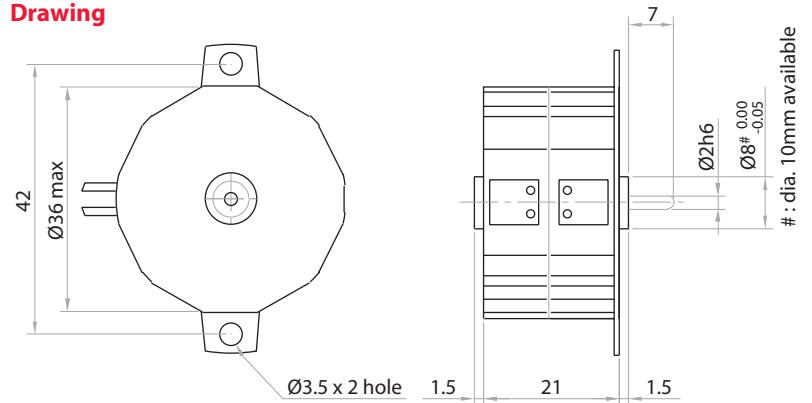

Ordering Data (eg.)

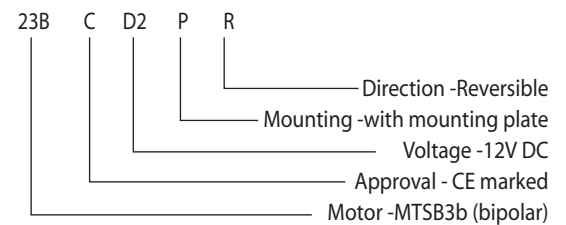

Torque Graphs

Start range (pull-in) with constant voltage power stage

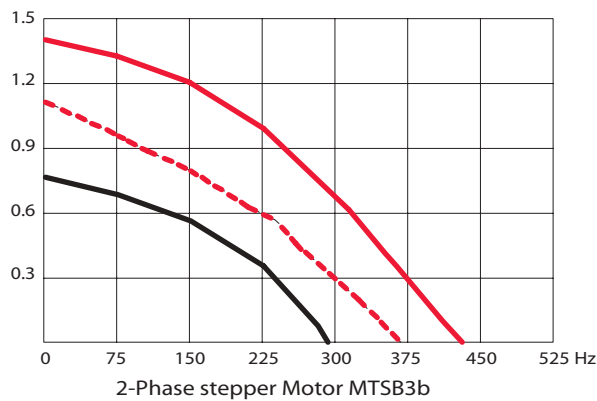

Start range (pull-in) with constant voltage power stage

