



Motor Series **MTR9b**

Reversible Synchronous Motor - 1000 RPM



Application

Reversible power drive for special purpose m/cs, actuators, pumps, label printing machines, medical and optical equipment, vending machines etc.

Design

The MTR9b reversing synchronous motor with permanent magnet rotor. The rotating field is produced with a phase-shift capacitor and double-stator with coils thus ensuring extremely quiet running and smooth operation. Long life is ensured by the ball bearings. Compared to normal permanent magnet synchronous motor that operates on tin can principle, these motors are more efficient. At same time the temperature rise is significantly higher in this motor. MTR9b is operated with single-phase AC current.

The same motor version can be used at 50Hz and 60Hz.

Standard Data

Motor type		Reversible synchronous
Ambient temperature operation	°C	-15...+55
Ambient temperature storage	°C	-20...+100
Thermal class	°C	120
Motor speed	rpm	1000 @ 50 Hz
Mounting		any position
Standard motor voltages	V	24, 110, 220 (others on request)
HVT		2.0 kV (motor voltage > 40V) or 0.6 kV (motor voltage < 40V) for 1 min.
Weight	gm	750
Temperature rise over ambient	°C	80 max.
Rotor shaft		Steel, ground and polished
Bearings		Ball Bearing
External dimensions		sqr 64 x 104 mm

Technical data

Rated voltage V_N	V	24	110	220
Operation capacitor (50 Hz) C_N	$\mu\text{F/VAC}$	48/50	2.5/250	0.6/400
Operation capacitor (60 Hz) C_N	$\mu\text{F/VAC}$	48/50	2.5/250	0.6/400
Lead colour (V_N)		Blue	White	Yellow
Tolerance of voltage	%	-10... +15% of rated voltage		
Duty cycle	%	100		
Rated frequency	Hz	50		60
Power output at rated voltage	W	10.1		11.3
Speed	rpm	1000		1200
Running torque at rated voltage	gm-cm	960		900
Power consumption at rated voltage	W	20.7		23.7
Detent torque	gm-cm	340		

Connection Diagram

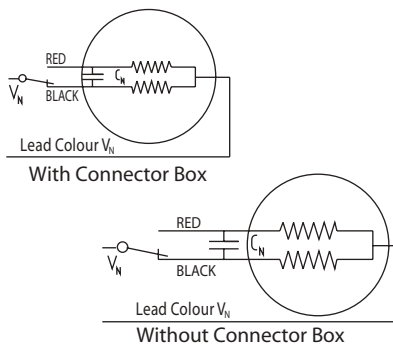

Ordering Data

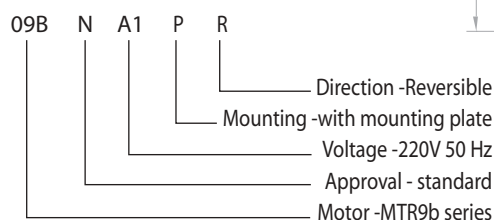

Motor Drawing

