

INSTALLATION and REMOVAL INSTRUCTIONS

MAV FLANGE COUPLING SERIES FC2008

- Flange Couplings MAV FC2008 provide a frictional **rigid connection between two shafts. Tight alignment of drive and driven shafts is required.**
- Flange Couplings MAV FC2008 are supplied ready for installation and are composed of:
 - two Shrink Discs MAV 2008
 - one male coupling flange
 - one female coupling flange
 - one set of flange bolts (hex head screws grade 10.9 + nuts grade 10)

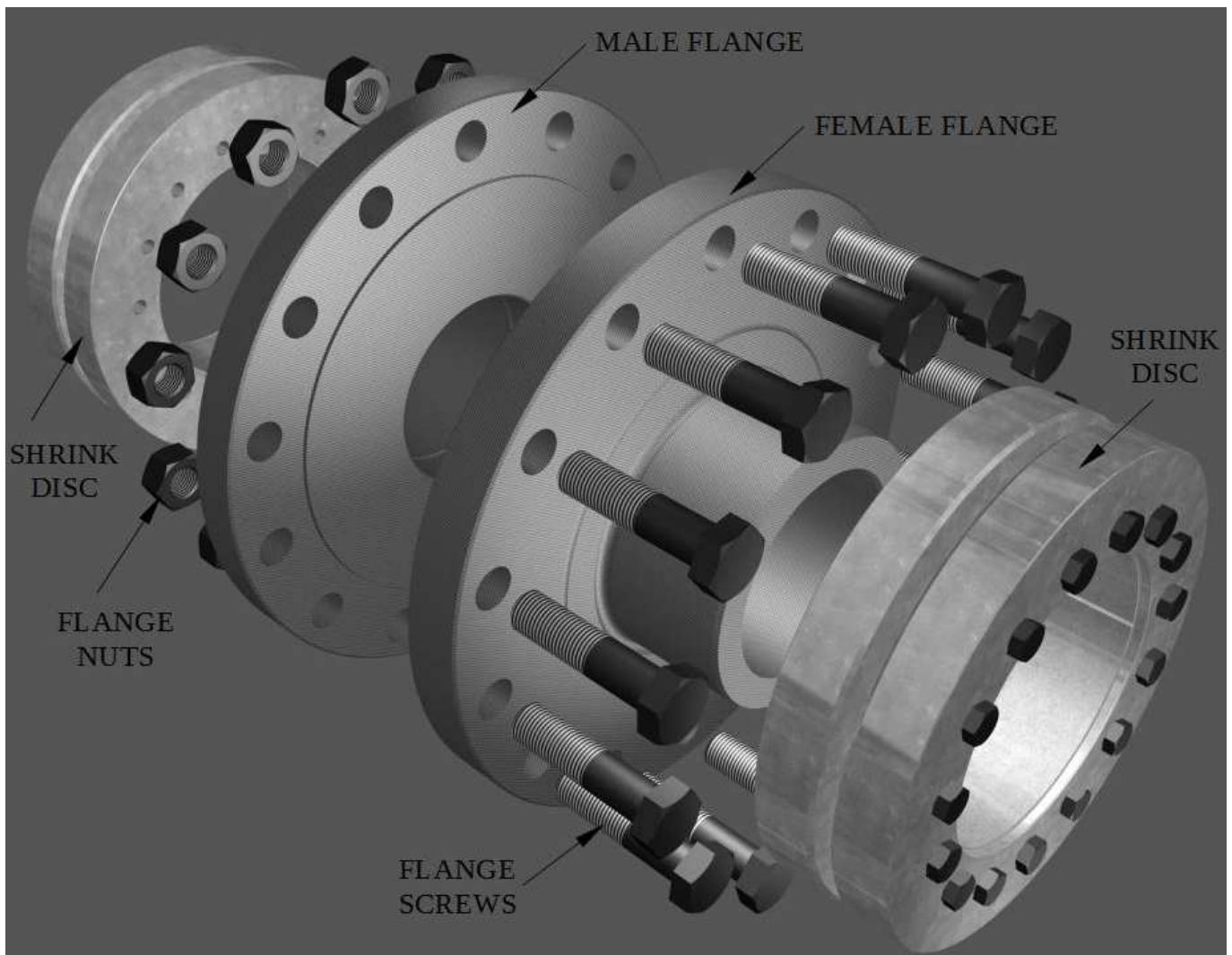

Figure 1. Composition of Flange Coupling FC2008

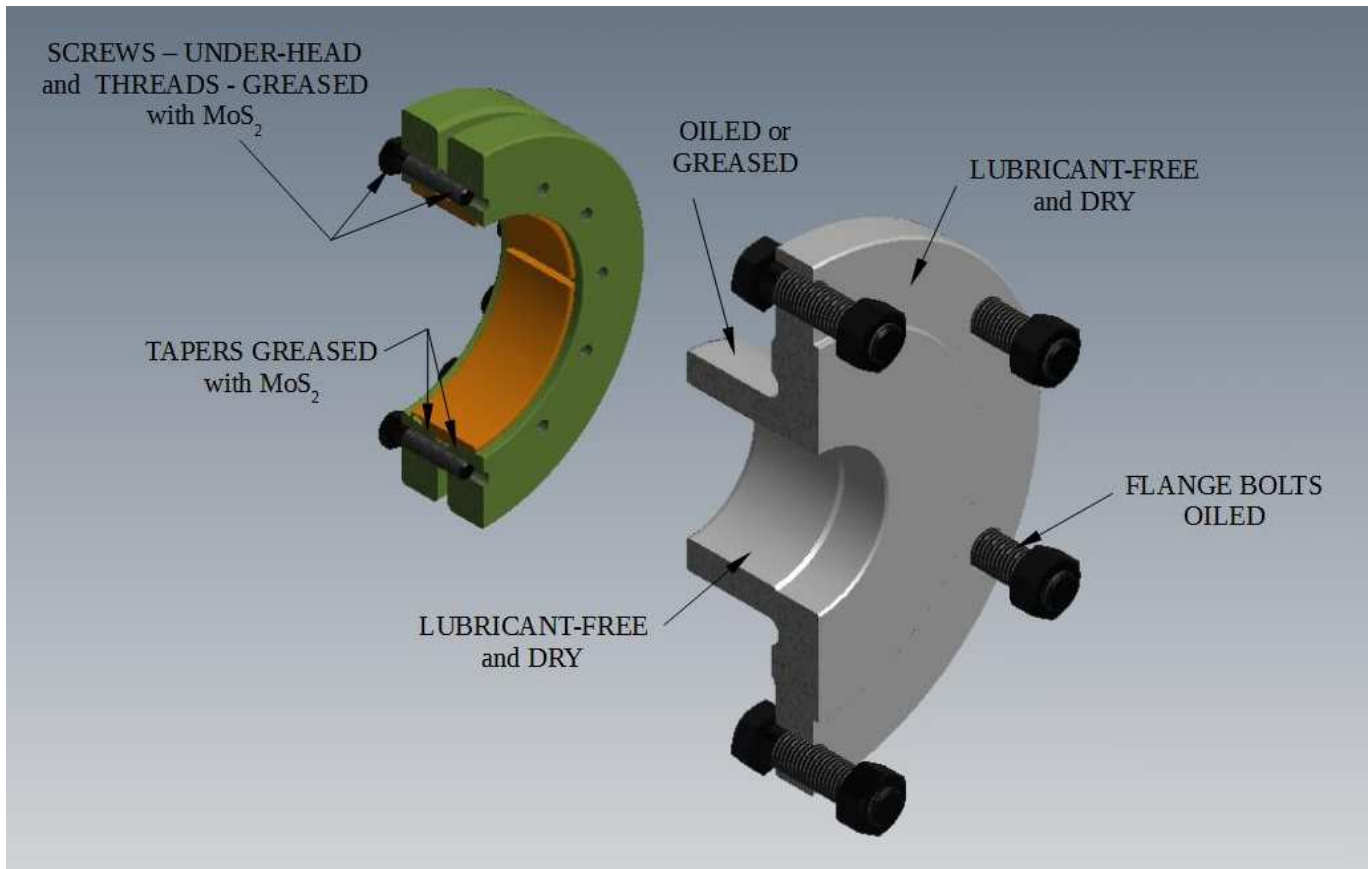

Figure 2. Lubrication of Flange Coupling FC2008

- Application loads are transmitted via friction across the fitting surface between shaft and flange bore. This surface must be carefully cleaned from any trace of lubricant prior to mounting flange onto shaft, to obtain a lubricant-free and dry steel-on-steel contact. **Any lubricant on the shaft/flange bore interface will greatly reduce the capacity of the connection.**

Application loads are then transmitted via friction across mating faces of the flanges (bolted connection). These faces must be carefully cleaned from any trace of lubricant, to obtain a lubricant-free and dry steel-on-steel contact. **Any lubricant on mating faces of the flanges will greatly reduce the capacity of the connection.**

Flange bolts must be lubricated with a film of ordinary machine oil (mineral/synthetic base oil with low content of additives). **DON'T USE low friction lubricants** based on MoS₂, graphite, copper and other similar components (e.g., Molykote, Never-Seeze or similar products).
- Recommended tolerances of shafts: if not specified otherwise by customer, refer to Shrink Disc table of tolerances according to MAV catalog. Otherwise, according to customer's specs.
- Recommended surface finish of shafts: $0.8 \leq Ra \leq 3.2 \mu\text{m}$.
- Tight clearance fits are typical of all functional surfaces. Mounting of all parts to be achieved **WITHOUT HEATING** or **OTHERS FORCED INSTALLATIONS**.

GENERAL RECOMMENDATIONS and WARNINGS

- Before installing or handling this product, read instructions carefully and completely. Due to possible danger to machinery or persons resulting from improper use of this product, it is very important to follow correct procedures. Proper installation, maintenance and operation procedures must be observed. All instructions included in this manual must be followed carefully. Handling, installation and removal of this product must be done by skilled personnel, familiar with the product, the application and all hazards involved.
- Suitable safety devices should be provided and applicable safety rules should be observed as specified in safety codes. Those are neither the responsibility of MAV S.p.A., nor are provided by MAV S.p.A.
- Contravention of install and safety instructions will void all claims under warranty.
- During storage or handling operations, use only tested and approved handling and/or lifting tools. Make always sure that components of Flange Coupling are secured against slipping, falling or rolling.
- Prior to initiating installation or removal procedures, check to ensure that no loads are acting on the Coupling, shafts or any connected components. Motor and drive train must be switched off and secured against accidental activation.

INSTALLATION

Each coupling half, composed of one flange and one Shrink Disc MAV 2008, will be fixed first on each shaft. The two coupling half assemblies will be aligned and finally bolted together.

INSTALLATION OF EACH COUPLING HALF (TIGHTENING OF SHRINK DISC MAV 2008)

Shrink Discs MAV 2008 are supplied ready for installation. However, prior to tightening of locking screws it is necessary to remove spacers that may have been used during shipping.

IMPORTANT. Never tighten locking screws prior to shaft installation, as inner ring of Shrink Disc and/or flange's hub can be permanently contracted even at relatively low tightening torques.

1. Clean flange's hub OD and Shrink Disc bore. Lightly lubricate hub OD before assembling Shrink Disc onto hub.
2. Carefully solvent clean and dry shaft and flange's hub bore of any lubricant prior to mounting hub onto shaft. This step is critical, as any lubricant on the shaft/hub bore interface will greatly reduce the capacity of the Shrink Disc connection.
3. Insert Shrink Disc onto flange until it bottoms out, then make the coupling half assembly slide onto shaft by using suitable lifting equipment.
The shaft must support completely the toleranced section of flange's hub bore.
Shaft end must not protrude from face of flange.
After confirming correct position of the coupling half assembly, hand-tighten 3 or 4 evenly spaced locking screws and make sure that outer collars of Shrink Disc are parallel. Hand-tighten remaining locking screws.
At the end of this stage, a light connection is achieved. Flange will not move axially respect to shaft during next tightening steps.

4. Use torque wrench and set it approximately 5% higher than specified locking screw tightening torque M_A . Tighten locking screws in either a clockwise or counterclockwise sequence, using approx. $\frac{1}{4}$ turns (even if initially some locking screws require a very low tightening torque to achieve $\frac{1}{4}$ turns) for several passes until $\frac{1}{4}$ turns can no longer be achieved.
5. Continue to apply overtorque for 1 or 2 more passes. This is required to compensate for a system-related relaxation of locking screws since tightening of a given screw will always relax adjacent screws. Without overtorquing, an infinite number of passes would be needed to reach specified tightening torque.
6. Reset torque wrench to specified torque (M_A) and check all locking screws. No screw should turn at this point, otherwise repeat Step 5 for 1 or 2 more passes. Once the screws are tightened, check the parallelism of outer collars, considering that maximum allowed error is 0.35% of the outer diameter of Shrink Disc. A larger error could cause loss of pressure and, as a consequence, reduced performances.
7. Using dial indicators, check flange runout as illustrated in Figure 3.
 - Indicator #1 Runout max 0.03 mm TIR (total indicator reading).
 - Indicator #2 Runout max 0.06 mm TIR (total indicator reading).
 - Indicator #3 Runout max 0.06 mm TIR (total indicator reading).
 Make sure runout values do not exceed listed limits. If runout is excessive, installation procedure must be repeated and flange runout rechecked. Excessive runout may generate additional stress in the coupling half assembly, promoting its premature failure.

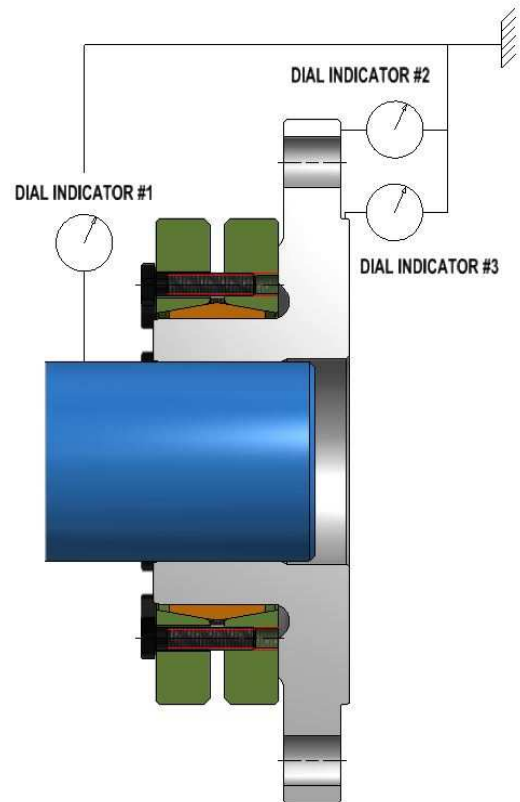

Figure 3. Coupling half installed (MAV 2008 tightened) – check of runout

CONNECTION OF THE TWO COUPLING HALF ASSEMBLIES

8. Carefully remove any trace of lubricant from mating faces of the flanges, to obtain a lubricant-free and dry contact. Make sure that flange bolts are oiled. **DON'T USE low friction lubricants** based on MoS_2 , graphite, copper and other similar components (e.g., Molykote, Never-Seeze or similar products).
9. With suitable lifting equipment, move drive/motor assembly into position parallel and in line with driven shaft using centering surfaces as a guide. Centering surfaces should match without need of shrinking. Should it be necessary, don't proceed further with flanges connection (additional stress may be generated, leading to premature failure). Adjust and recheck again the position of coupling half assemblies until correct alignment is confirmed, allowing a clearance fit between centering surfaces.
10. Make sure that all flange bolt holes are aligned.
11. Install and hand tighten all flange bolts.
12. Set a calibrated torque wrench to specified tightening torque. Tighten all flange bolts while allowing the drive/motor assembly to move as required to draw coupling half assemblies together (flexible support). Continue tightening until flanges are mated and all flange bolts are torqued to specified tightening torque.

13. At this point, torque arm can be fastened to the bed frame and lifting equipment removed. For safety reasons (support of drive in case of emergency), it is recommended lifting equipment to be removed only after connection of Flange Coupling is completed.
14. Using dial indicators per Figure 4, make sure that runout values are within 0.13 mm TIR (total indicator reading).

RECOMMENDATION. This kind of application is usually subjected to aggressive environment. Therefore, once connection of the two coupling half assemblies is completed, it is recommended to paint the outside of Flange Coupling with a suitable varnish.

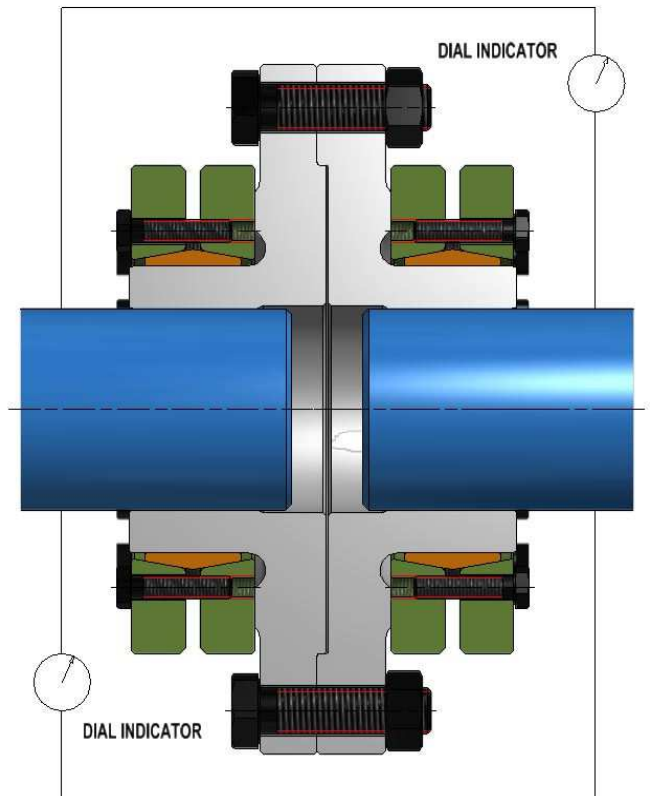

Figure 4. Flange Coupling installed – check of runout

REMOVAL

REMOVAL OF THE TWO COUPLING HALF ASSEMBLIES

1. Do not disconnect torque arm or tie rod until Coupling is completely disconnected.
2. Use suitable equipment to remove the weight of drive/motor assembly from Coupling and driven shaft. Lifting of drive must be done very carefully: make sure that loads are balanced to prevent swinging down of drive when Coupling is disconnected.
3. Loosen all flange bolts in sequence and remove them.
4. Separate the two coupling half assemblies.

REMOVAL OF EACH COUPLING HALF (RELEASING OF SHRINK DISC MAV 2008)

WARNING! DO NOT completely remove locking screws before locking rings are disengaged. A sudden separation of locking rings could involve high separation forces that may result in permanent injury or death. Be certain that locking rings are disengaged before completely removing locking screws.

5. Loosen all locking screws in several stages by using approx. ½ turns, following either a clockwise or counterclockwise sequence, until Shrink Disc can be moved on flange's hub. Shrink Disc, hub and shaft will return to their original fit clearances and can be disassembled.

REUSE of USED COUPLINGS

Before reuse, clean all components of the Coupling – Shrink Discs, flanges and all screws and nuts – and check their conditions. Permanent deformations, ovalizations, dents, corroded areas, are not admitted. In case of doubts, please contact MAV S.p.A. for advise.

If in good conditions, Couplings require thorough cleaning and re-lubrication before reuse.

- Disassemble all components of the Coupling and clean them thoroughly.
- Re-lubricate Shrink Discs as follows:
 - Dow Corning® *Molykote BR 2 Plus* (or equivalent) on locking screw threads and under-head;
 - Dow Corning® *Molykote G-Rapid Plus* (or equivalent) on tapers of inner or outer rings.
- Re-assemble Shrink Discs MAV 2008.
- Re-lubricate flange screws and nuts with ordinary machine oil (mineral/synthetic base oil with low content of additives).
- Follow these instructions for a new installation.