

INSTALLATION and REMOVAL INSTRUCTIONS

Locking Assembly MAV 6902



GENERAL RECOMMENDATIONS and WARNINGS

- Before installing or handling this product, read instructions carefully and completely. Due to possible danger to persons or machinery resulting from improper use of this product, it is very important to follow correct procedures. Proper installation, maintenance and operation procedures must be observed. All instructions included in this manual must be followed carefully. Handling, installation and removal of this product must be done by skilled personnel, familiar with the product, the application and all hazards involved.
- Suitable safety devices should be provided and applicable safety rules should be observed as specified in safety codes. Those are neither the responsibility of MAV S.p.A., nor are provided by MAV S.p.A.
- Contravention of install and safety instructions will void all claims under warranty.
- During storage or handling operations, use only tested and approved handling and/or lifting tools. Make always sure that components of Locking Assembly are secured against slipping, falling or rolling.
- Prior to initiating installation or removal procedures, check to ensure that no loads are acting on Locking Assembly, shaft or any connected component. Motor and drive train must be switched off and secured against accidental activation.

GENERAL INFORMATION

- Locking Assemblies MAV 6902 provide a rigid, zero-backlash, frictional keyless connection between a shaft and hubs such as gears, pulleys, cams, levers, rotors and many others.
They are suited for transmitting torque, axial load, bending moment and radial load, separately or in combination. Applied loads are transmitted via pressure and friction across the fitting surfaces between Locking Assembly, shaft and hub bore.
In tightened condition, Locking Assemblies exert high radial pressure on shaft and in hub bore.
- Locking Assemblies are supplied ready for installation and are composed of (fig. 1):
 - one inner ring (slotted), with integrated push-off threaded holes
 - one outer ring (slotted)
 - one spacer ring
 - one set of socket head cap screws ISO 4762 grade 12.9
- Lubrication. Functional values are rated with **screws, locking rings, shaft and hub contact areas coated with a film of mineral or synthetic-base oil** with low content of additives (specific corrosion-protection purpose products as well as products used to release oxidized connections are not recommended). **DON'T USE low friction lubricants** based on molybdenum disulphide, graphite, copper and other similar compounds (e.g., Molykote®, Never-Seeze® or similar products).
- Recommended shaft / hub bore tolerances: h8 / H8
- Recommended shaft / hub bore surface finish: $0.8 \leq Ra \leq 3.2 \mu\text{m}$

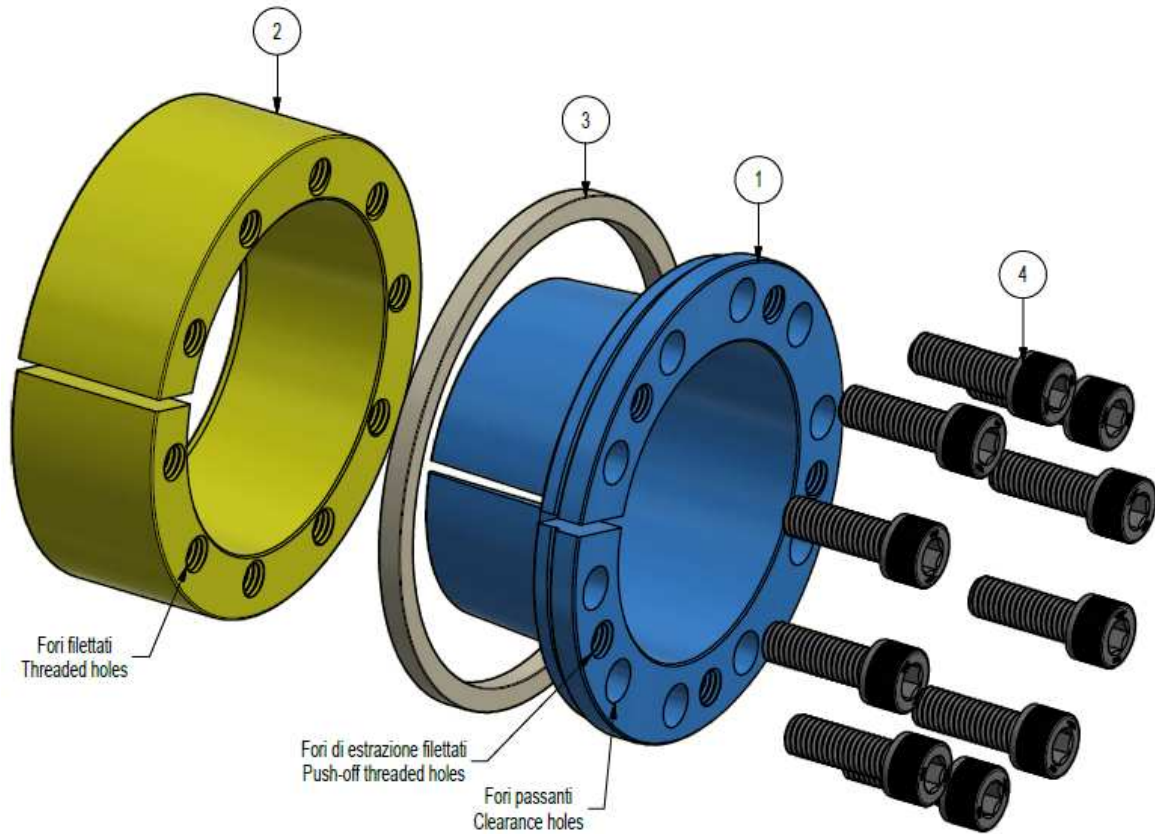

ELEM	QTÀ	DESCRIZIONE
1	1	ANELLO INTERNO / INNER RING
2	1	ANELLO ESTERNO / OUTER RING
3	1	ANELLO DISTANZIALE / SPACER RING
4	xx	VITE A TESTA CIL. ESAG. INCASS. ISO 4762 - 12.9 / S.H.C. SCREW ISO 4762 - 12.9

Fig. 1. Composition.

- Tightening torque. Functional values in the catalog are based on specified tightening torque (Ma). Tightening torque may be reduced up to $0.8 \cdot Ma$ (max reduction by 20%). A given reduction of tightening torque leads to a proportional reduction of functional values.
- After installation is completed, it is usually not necessary to re-check tightening torque after equipment has been in operation. However, loosening of the screws may occur in connections subject to severe operating conditions. In these instances, periodic check of screws tightening torque is recommended.

INSTALLATION

SAFETY NOTICE

Prior to initiating the installation procedure, check to ensure that no loads are acting on Locking Assembly, shaft or any connected component. Motor and drive train must be switched off and secured against accidental activation.

Locking Assemblies MAV 6902 are supplied ready for installation.

Should the unit be disassembled and re-assembled, make sure that the slits in inner and outer rings are aligned. The unit is assembled correctly if there are no holes in the outer ring behind threaded holes in the inner ring.

During tightening of Locking Assembly, no axial displacement of hub respect to shaft will occur.

1. Make sure that screws, locking rings, shaft and hub contact areas are clean and coated with a film of oil.
2. **For ease of installation, locking rings shall be disengaged** (fig. 2). Loosen all screws by two/three turns; then transfer and hand-tighten at least two screws into the push-off threaded holes in the inner ring.

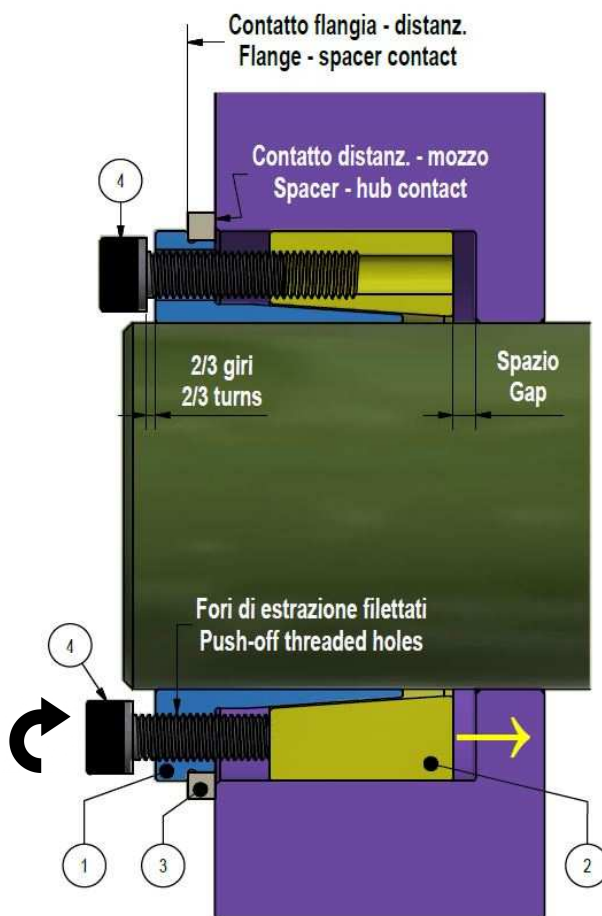

Fig. 2. Disengagement of locking rings and positioning of Locking Assembly.

3. Insert Locking Assembly into the hub bore and make it slide onto the shaft, making sure that connected components are positioned as required. **Inner and outer rings shall be completely supported by shaft respectively hub bore** (fig. 2). **The spacer ring shall be in full contact with inner ring's flange and face of the hub** (fig. 2). At this point, relocate the screws used to disengage the locking rings. Installation into hubs with shoulder requires a few mm's gap between outer ring and shoulder (fig. 2).

4. Tighten the screws by hand in a crosswise pattern, starting with a screw located at 90° approx. respect to slit (fig. 3), until fitting clearances with shaft and hub bore are bridged and connected components are slightly locked, while making sure that hub is aligned as required using a dial indicator. **Better centering of hub from the beginning of installation is essential for better centering when installation is completed.**
5. Use a torque wrench set approx. 5% higher than specified tightening torque (Ma), or reduced within admissible value. **Progressively tighten the screws in a crosswise pattern (fig. 3), using approx. ¼ turns for several passes until ¼ turns can no longer be achieved.** Start with a screw located at 90° approx. respect to slit; screws adjacent to slit shall be tightened in a row.

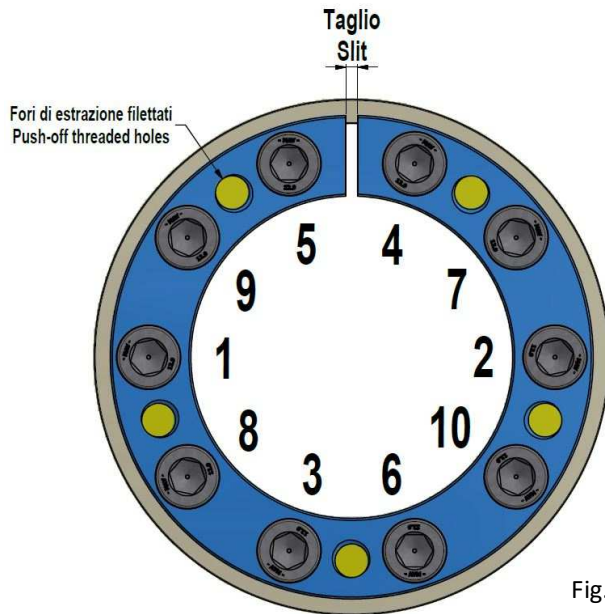

Fig. 3. Example of tightening pattern.

6. Still apply overtorque for a few more passes. This is required to compensate for a system-related relaxation of the screws since tightening of a given screw will always relax adjacent screws. Without overtorquing, a very large number of passes would be needed to reach specified tightening torque.
7. Reset the torque wrench to specified tightening torque (Ma), or reduced within admissible value, and check all screws in either a clockwise or counterclockwise sequence. The installation is completed as long as no screw can be turned further, otherwise repeat step 6. Once tightening procedure is completed, make sure that surfaces adjacent to slit are flush.

NOTE: for connections subject to corrosion, slits in inner and outer rings should be sealed with a suitable caulking compound and push-off threads should be plugged. Locking Assembly may also be protected with specific covers.

REMOVAL

SAFETY NOTICE

Prior to initiating the removal procedure, check to ensure that no loads are acting on Locking Assembly, shaft or any connected component. Motor and drive train must be switched off and secured against accidental activation.

 Some locking screws will be used for removal. The user shall make sure that the end tip of these screws is ground flat and chamfered, in order to prevent damage to the threads and allow their removal from push-off threaded holes. Screws with ground flat and chamfered end tip are not included in the scope of delivery.

1. Ensure that axial movement of locking rings – necessary for removal – is not restricted. Likewise, ensure that push-off threaded holes are in good conditions.

2. Loosen all screws by two/three turns; then transfer some screws into all push-off threaded holes in the inner ring.

 Progressively tighten these screws in a crosswise pattern, using approx. $\frac{1}{4}$ turns for several passes until the outer ring is released (fig. 4). Start with a screw located at 90° approx. respect to slit; screws adjacent to slit shall be tightened in a row.

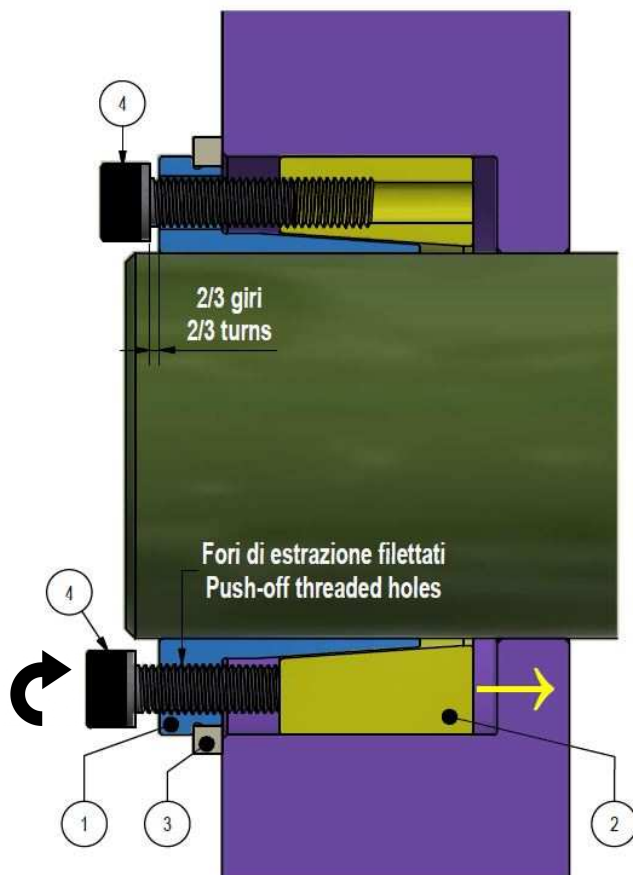

Fig. 4. Release of outer ring.