

Profil	SPZ	SPA	SPB
pitch width bw	8.5	11	14
c	2	2.8	3.5
f ± 0.2	8	10	12.5
e ± 0.1	12	15	19
t -0/+0.3	11	14	18
α = 34° ±0.5° for dw	50 - 80	63 - 118	90 - 190
top groove width b1 ± 0.05	9.72	12.71	16.14
α = 38° ±0.5° for dw	85 - 400	125 - 400	200 - 400
top groove width b1 ± 0.05	9.88	12.93	16.41

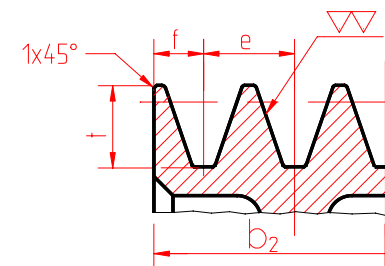
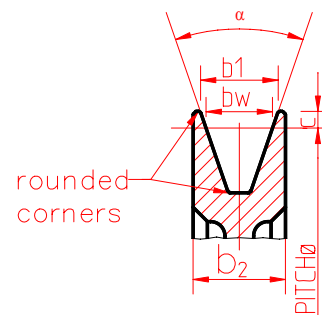

▽ (▽▽)

GJL-250

Phosphated

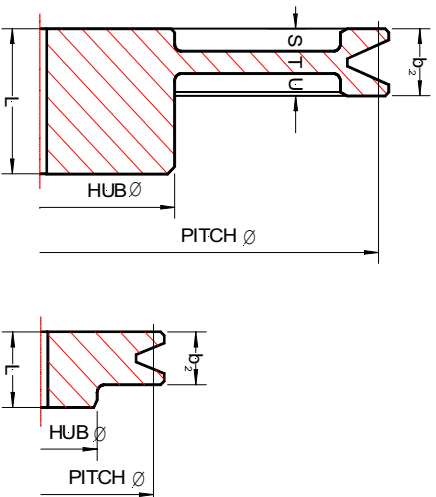

Type 1

Type 5

1 x SPZ

b₂ = 16 mm

Nabenscheibe / Full hub pulley

Wirkl. Ø pitch diameter dwh	Max. Bohrung bore Ø	Nabe hub Ø	Nabenlänge length of hub L	Type	S	T	U	Gewicht weight kg
50	22	35	28	5 ●	-	-	-	0,3
56	22	35	28	5 ●	-	-	-	0,4
63	28	45	28	5 ●	-	-	-	0,5
71	28	45	28	5 ●	-	-	-	0,6
75	28	45	28	5 ●	-	-	-	0,6
80	28	45	28	5 ●	-	-	-	0,7
85	28	45	28	5 ●	-	-	-	0,8
90	28	45	28	5 ●	-	-	-	0,8
95	30	50	28	1 ○	4,5	7	4,5	1,0
100	30	50	28	1 ○	4,5	7	4,5	1,1
106	30	50	28	1 ○	4,5	7	4,5	1,1
112	35	55	28	1 ○	4,5	7	4,5	1,1
118	35	55	28	1 ○	4,5	7	4,5	1,1
125	35	55	28	1 ○	4,5	7	4,5	1,3
132	35	55	28	1 ○	4,5	7	4,5	1,4
140	35	55	28	1 ○	4,5	7	4,5	1,4
150	35	55	28	1 ○	4,5	7	4,5	1,6
160	35	55	32	1 ○	4,5	7	4,5	1,8
180	35	55	32	1 ○	4,5	7	4,5	2,2
200	42	70	32	1 ○	4,5	7	4,5	2,6
224	45	75	35	1 x	3,5	9	3,5	3,7
250	45	75	35	1 x	3,5	9	3,5	4,5
280	45	75	35	1 x	3,5	9	3,5	5,3
315	45	75	35	1 x	3	10	3	6,1
355	45	75	35	1 x	3	10	3	7,5
400	45	75	35	1 x	3	10	3	7,1

☺ = Vollscheibe / solid pulley

⊗ = Bodenscheibe (mit oder ohne Spiegel) / plate pulley (with or without holes)

x = Armscheibe / arm pulley

2 X SPZ

b₂ = 28 mm

Nabenscheibe / Full hub pulley

Wirk. Ø pitch diameter dw	Max. Bohrung bore Ø	Nabe hub Ø	Nabenlänge length of hub L	Type	S	T	U	Gewicht weight kg
50	20	35	35	5 ●	-	-	-	0,4
56	25	40	35	5 ●	-	-	-	0,5
63	25	40	35	5 ●	-	-	-	0,6
71	25	40	35	5 ●	-	-	-	0,8
75	25	40	35	5 ●	-	-	-	0,9
80	32	55	35	5 ●	-	-	-	1,0
85	32	55	35	5 ●	-	-	-	1,2
90	32	55	35	5 ●	-	-	-	1,3
95	32	55	35	5 ●	-	-	-	1,4
100	32	55	35	5 ●	-	-	-	1,6
106	32	55	35	5 ○	-	-	-	1,8
112	32	55	35	1 ○	9,5	9	9,5	1,6
118	32	55	35	1 ○	9,5	9	9,5	1,6
125	32	55	35	1 ○	9,5	9	9,5	1,7
132	38	55	35	1 ○	9,5	9	9,5	1,9
140	40	65	40	1 ○	9,5	9	9,5	2,3
150	40	65	50	1 ○	9,5	9	9,5	2,5
160	40	65	40	1 ○	9,5	9	9,5	2,7
180	40	65	40	1 ○	9,5	9	9,5	3,1
200	40	65	40	1 ○	9,5	9	9,5	3,6
224	45	75	40	1 ○	8,5	11	8,5	5,1
250	45	75	40	1 x	8,5	11	8,5	5,0
280	48	75	45	1 x	8,5	11	8,5	6,3
315	48	75	45	1 x	7,5	13	7,5	9,2
355	50	80	45	1 x	7,5	13	7,5	10,9
400	50	80	50	1 x	7,5	13	7,5	12,6

- = Vollscheibe / solid pulley
- = Bodenscheibe (mit oder ohne Spiegel) / plate pulley (with or without holes)
- x = Armscheibe / arm pulley

3 X SPZ

b₂ = 40mm

Nabenscheibe / Full hub pulley

Wirk. Ø pitch diameter	Max. Bohrung bore	Nabe hub	Nabenlänge length of hub	Type	S	T	U	Gewicht weight kg
50	20	-	40	3 ●	-	-	-	0,5
56	25	-	40	3 ●	-	-	-	0,6
63	25	-	40	3 ●	-	-	-	0,8
67	32	-	40	3 ●	-	-	-	0,9
71	32	-	40	3 ●	-	-	-	1,0
75	32	-	40	3 ●	-	-	-	1,1
80	38	-	40	3 ●	-	-	-	1,3
85	38	-	40	3 ●	-	-	-	1,4
90	38	-	40	3 ●	-	-	-	1,7
95	38	-	40	3 ●	-	-	-	1,9
100	38	-	40	3 ●	-	-	-	2,1
106	38	-	40	3 ●	-	-	-	2,3
112	38	-	40	3 ●	-	-	-	2,6
118	38	-	40	3 ●	-	-	-	2,9
125	38	-	40	3 ●	-	-	-	3,3
132	38	-	40	3 ●	-	-	-	3,7
140	42	70	40	1 ○	14,5	11	14,5	2,7
150	42	70	40	1 ○	14,5	11	14,5	3,2
160	45	75	45	1 ○	14,5	11	14,5	3,6
170	45	75	45	1 ○	14,5	11	14,5	4,0
180	45	75	45	1 ○	14,5	11	14,5	4,4
190	45	75	45	1 ○	14,5	11	14,5	4,6
200	50	80	45	1 ○	14,5	11	14,5	4,8
224	50	80	45	1 ○	14,0	12	14,0	5,3
236	50	80	45	1 ○	14,0	12	14,0	5,5
250	50	80	45	1 x	14,0	12	14,0	5,7
280	50	80	50	1 x	14,0	12	14,0	8,8
315	50	80	50	1 x	13,5	13	13,5	10,0
355	55	90	50	1 x	13,5	13	13,5	10,1
400	55	90	50	1 x	13,5	13	13,5	14,3

- = Vollscheibe / solid pulley
- = Bodenscheibe (mit oder ohne Spiegel) / plate pulley (with or without holes)
- x = Armscheibe / arm pulley

1 X SPA

b₂ = 20 mm

Nabenscheibe / Full hub pulley

Wirk. Ø pitch diameter	Max. Bohrung bore	Nabe hub	Nabenlänge length of hub	Type	S	T	U	Gewicht weight kg
50	20	35	35	5 ●	-	-	-	0,4
56	20	35	35	5 ●	-	-	-	0,4
63	25	41	35	5 ●	-	-	-	0,5
71	25	41	35	5 ●	-	-	-	0,7
75	25	41	35	5 ●	-	-	-	0,9
80	35	55	35	5 ●	-	-	-	0,9
85	35	55	35	5 ●	-	-	-	1,0
90	35	55	35	5 ●	-	-	-	1,1
95	35	55	35	5 ●	-	-	-	1,2
100	35	55	35	5 ●	-	-	-	1,3
106	35	55	35	1 ○	6,5	7	6,5	1,3
112	35	55	35	1 ○	6,5	7	6,5	1,4
118	35	55	35	1 ○	6,5	7	6,5	1,4
125	35	55	35	1 ○	6,5	7	6,5	1,5
132	35	55	35	1 ○	6,5	7	6,5	1,6
140	35	55	35	1 ○	6,5	7	6,5	1,8
150	35	55	40	1 ○	6,5	7	6,5	2,0
160	38	60	40	1 ○	6,5	7	6,5	2,3
170	38	60	40	1 ○	6,5	7	6,5	2,5
180	40	65	40	1 ○	6,5	7	6,5	2,8
190	40	65	40	1 ○	6,5	7	6,5	3,0
200	40	65	40	1 ○	6,5	7	6,5	2,9
212	40	65	40	1 ○	6,5	7	6,5	3,2
224	40	65	40	1 ○	5,5	9	5,5	3,5
236	40	65	50	1 ○	5,5	9	5,5	4,5
250	45	75	50	1 ○	5,5	9	5,5	5,2
280	45	75	50	1 ○	5,5	9	5,5	5,8
300	45	75	45	1 x	5	10	5	6,4
315	50	80	50	1 x	5	10	5	6,9
355	50	80	50	1 x	5	10	5	8,0
400	55	90	50	1 x	5	10	5	8,5
450	60	100	50	1 x	5	10	5	13,7
500	60	100	50	1 x	5	10	5	16,6

- = Vollscheibe / solid pulley
- = Bodenscheibe (mit oder ohne Spiegel) / plate pulley (with or without holes)
- x = Armscheibe / arm pulley

2 X SPA

b₂ = 35 mm

Nabenschleibe / Full hub pulley

Wirk. Ø pitch diameter	Max. Bohrung bore	Nabe hub	Nabenlänge length of hub	Type	S	T	U	Gewicht weight
50	24	-	L	3 ●	-	-	-	0,5
56	24	-	-	3 ●	-	-	-	0,6
63	28	45	40	5 ●	-	-	-	0,7
71	30	50	45	5 ●	-	-	-	1,0
75	35	55	45	5 ●	-	-	-	1,1
80	35	55	45	5 ●	-	-	-	1,3
85	35	55	45	5 ●	-	-	-	1,4
90	35	55	45	5 ●	-	-	-	1,6
95	35	55	45	5 ●	-	-	-	1,7
100	35	55	45	5 ●	-	-	-	1,9
106	35	55	45	5 ●	-	-	-	2,1
112	40	65	45	1 ○	13	9	13	2,1
118	40	65	45	1 ○	13,5	8	13,5	2,2
125	40	65	45	1 ○	13	9	13	2,4
132	40	65	45	1 ○	13	9	13	2,6
140	40	65	45	1 ○	13	9	13	2,8
150	40	65	45	1 ○	13	9	13	2,9
160	40	65	45	1 ○	13	9	13	3,1
170	45	75	45	1 ○	13	9	13	3,7
180	45	75	50	1 ○	13	9	13	4,1
190	45	75	50	1 ○	13	9	13	4,3
200	45	75	50	1 ○	13	9	13	4,7
212	45	75	50	1 ○	13	9	13	4,9
224	45	75	50	1 x	12	11	12	5,0
236	45	75	50	1 x	12	11	12	6,0
250	50	80	50	1 x	12	11	12	7,0
280	50	80	50	1 x	12	11	12	6,7
300	50	80	50	1 x	12	11	12	7,9
315	50	80	50	1 x	12	11	12	8,5
355	50	80	60	1 x	12	11	12	10,2
400	55	90	60	1 x	12	11	12	11,7
450	60	100	60	1 x	10	15	10	17,2
500	60	100	60	1 x	10	15	10	20,0
560	60	100	60	1 x	10	15	10	21,8
630	65	100	80	1 x	10	15	10	25,7

- = Vollscheibe / solid pulley
- = Bodenschleibe (mit oder ohne Spiegel) / plate pulley (with or without holes)
- x = Armscheibe / arm pulley

3 X SPA

b₂ = 50mm

Nabenscheibe / Full hub pulley

Wirk. Ø pitch diameter	Max. Bohrung bore	Nabe hub	Nabenlänge		Type	S	T	U	Gewicht weight
			hub	length of hub					
63	25	Ø	Ø	L	3 ●	-	-	-	0,9
71	32	-	-	50	3 ●	-	-	-	1,2
75	32	-	-	50	3 ●	-	-	-	1,5
80	32	-	-	50	3 ●	-	-	-	1,5
85	38	-	-	50	3 ●	-	-	-	1,7
90	38	-	-	50	3 ●	-	-	-	1,9
95	38	-	-	50	3 ●	-	-	-	2,2
100	38	-	-	50	3 ●	-	-	-	2,4
106	38	-	-	50	3 ●	-	-	-	2,7
112	38	-	-	50	3 ●	-	-	-	3,1
118	42	-	-	50	3 ●	-	-	-	3,5
125	42	70	Ø	50	2 ○	19,5	11	19,5	3,2
132	45	75	Ø	50	2 ○	19,5	11	19,5	3,4
140	45	75	Ø	50	2 ○	19,5	11	19,5	3,7
150	45	75	Ø	50	2 ○	19,5	11	19,5	4,0
160	45	75	Ø	50	2 ○	20	10	20	4,2
170	50	80	Ø	50	2 ○	19,5	11	19,5	4,7
180	50	80	Ø	50	2 ○	19,5	11	19,5	5,1
190	50	80	Ø	50	2 ○	19,5	11	19,5	5,4
200	50	80	Ø	50	2 ○	19,5	11	19,5	5,7
224	55	90	Ø	50	2 ○	19	12	19	7,3
236	55	90	Ø	50	2 ○	19	12	19	7,1
250	55	90	Ø	50	2 ○	19	12	19	7,9
280	55	90	Ø	50	2 x	19	12	19	9,6
300	60	100	Ø	60	1 x	19,5	11	19,5	10,1
315	60	100	Ø	60	1 x	18,5	13	18,5	10,6
355	60	100	Ø	60	1 x	18,5	13	18,5	14,7
400	65	105	Ø	65	1 x	18,5	13	18,5	15,3
450	65	105	Ø	65	1 x	17,5	15	17,5	16,8
500	65	105	Ø	65	1 x	17,5	15	17,5	20,6
560	65	105	Ø	65	1 x	17,5	15	17,5	25,8
630	65	105	Ø	65	1 x	17,5	15	17,5	30,0

- = Vollscheibe / solid pulley
- = Bodenscheibe (mit oder ohne Spiegel) / plate pulley (with or without holes)
- x = Armscheibe / arm pulley

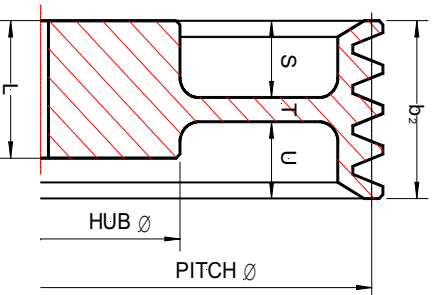

Type 2

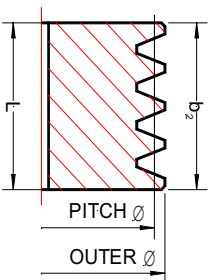

Type 3

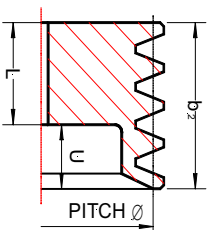

Type 4

4 x SPA

b₂ = 65 mm

Nabenscheibe / Full hub pulley

Wirkl. pitch diameter dw	Max. Bohrung bore Ø	Nabe hub Ø	Nabenlänge length of hub L	Type	S	T	U	Gewicht weight kg
63	30	-	65	3 ●	-	-	-	1,2
71	30	-	65	3 ●	-	-	-	1,5
75	30	-	65	3 ●	-	-	-	1,7
80	35	-	65	3 ●	-	-	-	1,9
85	35	-	65	3 ●	-	-	-	2,2
90	42	-	65	3 ●	-	-	-	2,5
95	42	-	50	3 ●	-	-	-	2,8
100	42	-	50	4 ●	-	-	15	2,8
106	42	-	50	4 ●	-	-	15	3,1
112	42	-	50	4 ●	-	-	15	3,4
118	42	-	50	4 ●	-	-	15	3,9
125	42	-	50	4 ●	-	-	15	4,4
132	42	-	50	4 ●	-	-	15	5,0
140	42	-	50	4 ●	-	-	15	5,6
150	45	75	50	2 ○	25	15	25	4,8
160	50	80	50	2 ○	26,5	13	26,5	5,2
170	50	80	60	2 ○	26,5	13	26,5	5,3
180	50	80	60	2 ○	26,5	13	26,5	6,2
190	50	80	60	2 ○	26,5	13	26,5	6,6
200	60	100	60	2 ○	26,5	13	26,5	8,1
224	60	100	60	2 ○	26	13	26	9,1
236	60	100	60	2 ○	26	13	26	9,6
250	60	100	60	2 ○	26	13	26	9,4
280	60	100	60	2 x	26	13	26	11,6
300	60	100	60	2 x	25,5	14	25,5	13,7
315	60	100	60	2 x	25,5	14	25,5	14,4
355	65	105	60	2 x	25,5	14	25,5	15,7
400	65	105	65	2 x	25,5	14	25,5	19,2
450	70	110	70	2 x	24,5	16	24,5	23,6
500	70	110	70	2 x	24,5	16	24,5	26,7
560	70	110	70	2 x	24,5	16	24,5	30,4
630	70	110	70	2 x	24,5	16	24,5	37,7

- = Vollscheibe / solid pulley
- = Bodenscheibe (mit oder ohne Spiegel) / plate pulley (with or without holes)
- x = Armscheibe / arm pulley

5 X SPA

b₂ = 80 mm

Nabenscheibe / Full hub pulley

Wirk. ∅ pitch diameter dw	Max. Bohrung bore ∅	Nabe		Nabenlänge length of hub L	Type	S	T	U	Gewicht weight kg
		hub ∅	length of hub						
80	35	-	80	3 ●	-	-	-	2,4	
85	35	-	80	3 ●	-	-	-	2,7	
90	42	-	80	3 ●	-	-	-	3,0	
95	42	-	80	4 ●	-	-	30	3,5	
100	42	-	50	4 ●	-	-	30	3,1	
106	42	-	50	4 ●	-	-	30	3,4	
112	42	-	50	4 ●	-	-	30	3,8	
118	48	-	50	4 ●	-	-	30	4,2	
125	48	-	50	4 ●	-	-	30	4,9	
132	48	-	50	4 ●	-	-	30	5,3	
140	48	-	50	4 ●	-	-	30	6,1	
150	50	80	50	2 ○	33,5	13	33,5	5,3	
160	50	80	50	2 ○	33,5	13	33,5	5,8	
170	50	80	50	2 ○	33,5	13	33,	6,6	
180	55	90	65	2 ○	33,5	13	33,5	7,5	
190	55	90	65	2 ○	32,5	15	32,5	8,0	
200	60	100	65	2 ○	32,5	15	32,5	9,3	
224	60	100	65	2 ○	32,5	15	32,5	10,0	
236	60	100	65	2 ○	32,5	15	32,5	10,7	
250	65	105	65	2 x	32,5	15	32,5	11,0	
280	65	105	65	2 x	32,5	15	32,5	13,8	
300	65	105	70	2 x	32,5	15	32,5	14,5	
315	65	105	70	2 x	32,5	15	32,5	15,2	
355	70	110	70	2 x	32,5	15	32,5	16,3	
400	70	110	70	2 x	32,5	15	32,5	17,2	
450	70	110	70	2 x	32,5	15	32,5	21,8	
500	75	120	70	2 x	32,5	15	32,5	29,1	
560	75	120	70	2 x	32,5	15	32,5	32,7	
630	75	120	75	2 x	32,5	15	32,5	37,2	

- = Vollscheibe / solid pulley
- = Bodenscheibe (mit oder ohne Spiegel) / plate pulley (with or without holes)
- x = Armscheibe / arm pulley

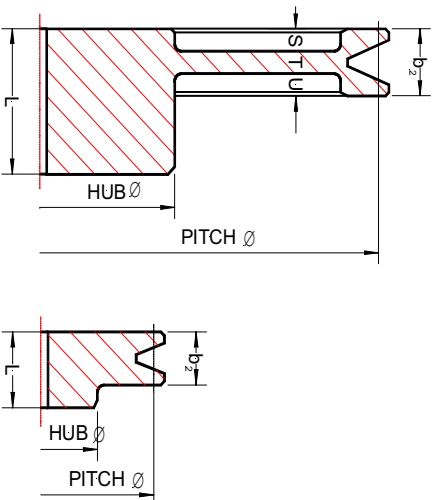

Type 1

Type 5

1 x SPB

b₂ = 25 mm

Nabenschleibe / Full hub pulley

Wirk. Ø pitch diameter dw	Max. Bohrung bore Ø	Nabe hub Ø	Nabenlänge length of hub L	Type	S	T	U	Gewicht weight kg
71	28	45	40	5 ●	-	-	-	0,9
80	28	55	35	5 ●	-	-	-	1,0
90	35	55	35	5 ●	-	-	-	1,2
95	35	55	35	5 ●	-	-	-	1,3
100	35	55	35	5 ●	-	-	-	1,4
106	35	55	35	5 ●	-	-	-	1,6
112	35	55	35	5 ●	-	-	-	1,8
118	35	55	35	1 ○	9,5	6	9,5	1,6
125	35	55	35	1 ○	9	7	9	1,7
132	35	55	35	1 ○	9	7	9	1,8
140	35	55	35	1 ○	9,5	6	9,5	1,9
150	35	55	40	1 ○	9	6	9	2,2
160	40	65	40	1 ○	9	6	9	2,6
170	40	65	40	1 ○	9	6	9	2,8
180	40	65	40	1 ○	9	6	9	3,1
190	40	65	40	1 ○	9	6	9	3,2
200	40	65	40	1 ○	9	6	9	3,3
212	40	65	40	1 ○	8	9	8	3,9
224	45	75	45	1 ○	8	9	8	4,5
236	45	75	45	1 ○	8	9	8	5,2
250	45	75	45	1 ○	8	9	8	5,3
280	50	80	50	1 x	8	9	8	6,3
300	50	80	50	1 x	8	9	8	7,3
315	50	80	50	1 x	7,5	10	7,5	7,8
355	50	80	50	1 x	7,5	10	7,5	9,9
400	50	80	55	1 x	7,5	10	7,5	12,2
450	50	80	55	1 x	7,5	10	7,5	17,0
500	50	80	55	1 x	7,5	10	7,5	19,9

- = Vollschleibe / solid pulley
- = Bodenschleibe (mit oder ohne Spiegel) / plate pulley (with or without holes)
- x = Armschleibe / arm pulley

2 X SPB

b₂ = 44 mm

Nabenscheibe / Full hub pulley

Wirk. ∅ pitch diameter dw	Max. Bohrung bore ∅	Nabe		Nabenlänge length of hub L	Type	S	T	U	Gewicht weight kg
		hub ∅	length of hub						
80	28	-	60	60	5 ●	-	-	-	1,6
90	38	60	60	60	5 ●	-	-	-	2,0
95	38	60	60	60	5 ●	-	-	-	2,2
100	40	65	60	60	5 ●	-	-	-	2,3
106	40	65	60	60	5 ●	-	-	-	2,8
112	40	65	65	55	5 ●	-	-	-	2,9
118	40	65	65	55	5 ●	-	-	-	3,3
125	40	65	65	55	5 ●	-	-	-	4,0
132	40	65	65	55	1 ○	17	10	17	3,6
140	40	65	65	55	1 ○	17	10	17	3,8
150	40	65	65	55	1 ○	17	10	17	4,1
160	45	75	55	55	1 ○	17	10	17	4,8
170	45	75	55	55	1 ○	17	10	17	5,1
180	45	75	50	50	1 ○	17	10	17	5,3
190	50	80	50	50	1 ○	17	10	17	5,8
200	50	80	50	50	1 ○	17	10	17	5,9
212	50	80	50	50	1 ○	17	10	17	6,3
224	50	80	50	50	1 ○	16	12	16	6,7
236	55	90	50	50	1 ○	16	12	16	7,0
250	55	90	50	50	1 ○	16	12	16	8,4
280	55	90	50	50	1 x	16	12	16	9,5
300	55	90	50	50	1 x	16	12	16	10,5
315	60	100	60	60	1 x	15,5	13	15,5	12,3
355	60	100	60	60	1 x	15,5	13	15,5	14,3
400	65	105	60	60	1 x	15,5	13	15,5	17,7
450	65	105	60	60	1 x	15	14	15	21,0
500	70	115	65	65	1 x	15	14	15	26,0
560	70	115	75	75	1 x	15	14	15	30,2
630	70	115	75	75	1 x	15	14	15	32,4

- = Vollscheibe / solid pulley
- = Bodenscheibe (mit oder ohne Spiegel) / plate pulley (with or without holes)
- x = Armscheibe / arm pulley

3 X SPB

b₂ = 63 mm

Nabenscheibe / Full hub pulley

Wirk. Ø pitch diameter dw	Max. Bohrung bore Ø	Nabe hub Ø	Nabenlänge length of hub		Type	S	T	U	Gewicht weight kg
			L						
80	38	-	55		4 ●	-	-	8	2,0
90	38	-	55		4 ●	-	-	8	2,2
100	38	-	55		4 ●	-	-	8	2,8
106	38	-	55		4 ●	-	-	8	3,2
112	38	-	50		4 ●	-	-	8	3,4
118	42	-	50		4 ●	-	-	13	3,8
125	42	-	50		4 ●	-	-	13	4,2
132	42	-	50		4 ●	-	-	13	4,7
140	42	-	50		4 ●	-	-	13	5,3
150	45	75	50		2 ○	26	11	26	4,8
160	50	80	50		2 ○	26	11	26	5,1
170	50	80	50		2 ○	26	11	26	5,5
180	50	80	50		2 ○	26	11	26	5,8
190	55	90	50		2 ○	26	11	26	6,7
200	55	90	50		2 ○	25,5	12	25,5	7,2
212	55	90	50		2 ○	25,5	12	25,5	7,8
224	55	90	50		2 ○	25,5	12	25,5	7,9
236	55	90	50		2 ○	25,5	12	25,5	8,4
250	60	100	60		2 ○	25,5	12	25,5	10,3
280	60	100	60		2 x	25,5	12	25,5	11,7
300	60	100	60		2 x	24,5	14	24,5	12,7
315	65	105	60		2 x	24,5	14	24,5	14,4
355	65	105	60		2 x	24,5	14	24,5	15,3
400	70	110	65		1 x	24,5	14	24,5	17,8
450	70	110	65		1 x	24	15	24	23,0
500	75	120	75		1 x	24	15	24	27,0
560	75	120	75		1 x	24	15	24	33,0
630	75	120	75		1 x	24	15	24	36,7

- = Vollscheibe / solid pulley
- = Bodenscheibe (mit oder ohne Spiegel) / plate pulley (with or without holes)
- x = Armscheibe / arm pulley

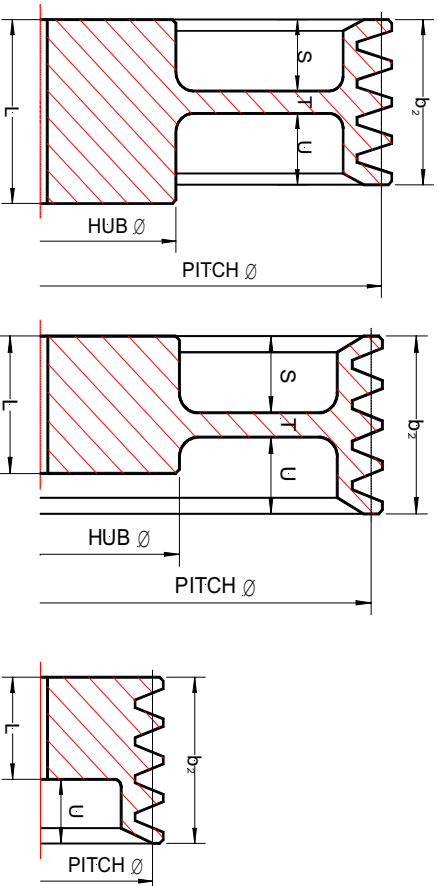

4 x SPB

b₂ = 82 mm

Nabenscheibe / Full hub pulley

Wirk. Ø pitch diameter d _w	Max. Bohrung bore Ø	Nabe hub Ø	Nabenlänge length of hub L	Type	S	T	U	Gewicht weight kg
80	42	Ø	50	4 ●	-	-	32	2,5
90	42		50	4 ●	-	-	32	2,6
100	42	-	50	4 ●	-	-	32	3,1
106	42	-	50	4 ●	-	-	32	3,5
112	42	-	50	4 ●	-	-	32	3,8
118	42	-	50	4 ●	-	-	32	4,3
125	42	-	50	4 ●	-	-	32	4,8
132	42	-	50	4 ●	-	-	32	5,3
140	42	-	50	4 ●	-	-	32	6,0
150	42	-	50	4 ●	-	-	32	6,8
160	50	80	60	2 ○	35	12	35	6,5
170	50	80	60	2 ○	35	12	35	7,2
180	55	90	60	2 ○	35	12	35	7,7
190	55	90	60	2 ○	35	12	35	8,2
200	55	90	60	2 ○	35	12	35	8,9
212	60	100	60	2 ○	34,5	13	34,5	10,0
224	60	100	60	2 ○	34,5	13	34,5	10,6
236	60	100	60	2 ○	34,5	13	34,5	10,6
250	65	105	65	2 ○	34,5	13	34,5	13,1
280	65	105	65	2 ○	34	14	34	14,0
300	65	105	65	2 ○	34	14	34	15,2
315	70	110	65	2 ○	34	14	34	16,4
355	70	110	65	2 x	34	14	34	17,9
400	75	120	75	2 x	33,5	15	33,5	21,9
450	75	120	75	2 x	33,5	15	33,5	26,8
500	75	125	85	1 x	33,5	15	33,5	30,3
560	80	130	85	1 x	33,5	15	33,5	37,9
630	80	130	90	1 x	33,5	15	33,5	43,5

- = Vollscheibe / solid pulley
- = Bodenscheibe (mit oder ohne Spiegel) / plate pulley (with or without holes)
- x = Armscheibe / arm pulley

5 x SPB

b_z = 101 mm

Nabenscheibe / Full hub pulley

Wirk. Ø pitch diameter d _w	Max. Bohrung bore Ø	Nabe hub Ø	Nabenlänge length of hub L	Type	S	T	U	Gewicht weight kg
112	42	-	50	4 ●	-	-	51	4,4
118	42	-	50	4 ●	-	-	51	4,8
125	42	-	50	4 ●	-	-	51	5,4
132	42	-	50	4 ●	-	-	51	5,9
140	48	-	60	4 ●	-	-	41	7,2
150	48	-	60	4 ●	-	-	41	8,3
160	55	90	60	2 ○	25	26	50	8,1
170	60	100	60	2 ○	25	26	50	9,4
180	60	100	70	2 ○	28	20	53	10,0
190	60	100	70	2 ○	25	26	50	10,7
200	60	100	70	2 ○	28	20	53	11,6
212	65	105	70	2 ○	25	26	50	13,4
224	65	105	70	2 ○	44	13	44	12,7
236	65	105	70	2 ○	44	13	44	15,5
250	75	120	75	2 ○	44	13	44	15,7
280	75	120	75	2 ○	43,5	14	43,5	17,2
300	75	120	75	2 x	43,5	14	43,5	18,9
315	75	120	75	2 x	43	15	43	20,6
355	75	120	75	2 x	43	15	43	21,8
400	80	130	85	2 x	43	15	43	28,0
450	80	130	85	2 x	42,5	16	42,5	31,4
500	85	135	90	2 x	42,5	16	42,5	37,5
560	85	140	90	2 x	42,5	16	42,5	43,4
630	85	140	105	1 x	42,5	16	42,5	53,6

- = Vollscheibe / solid pulley
- = Bodenscheibe (mit oder ohne Spiegel) / plate pulley (with or without holes)
- x = Armscheibe / arm pulley

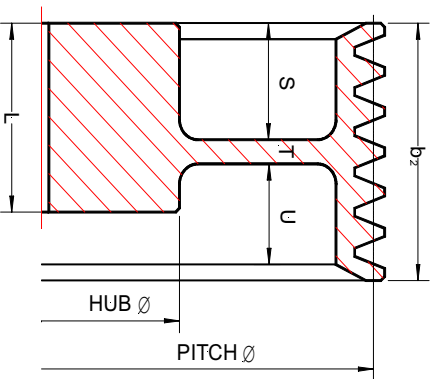

Type 2

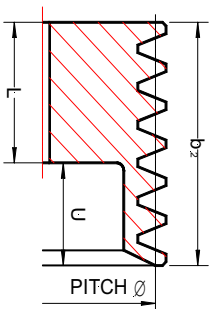

Type 4

6 x SPB

b_z = 120 mm

Nabenschleibe / Full hub pulley

Wirkl. Ø pitch diameter	Max. Bohrung bore	Nabe hub	Nabenlänge length of hub	Type	S	T	U	Gewicht weight
125	48	-	60	4 ●	-	-	60	6,4
132	48	-	60	4 ●	-	-	60	7,2
140	48	-	60	4 ●	-	-	60	8,4
150	48	-	60	4 ●	-	-	60	9,7
160	55	-	65	4 ●	-	-	55	11,1
170	55	-	65	4 ●	-	-	55	11,8
180	60	-	70	4 ●	-	-	50	13,8
190	60	-	70	4 ●	-	-	50	15,3
200	60	-	80	4 ●	-	-	40	18,6
224	70	110	80	2 ○	52	16	52	15,3
236	70	110	80	2 ○	52	16	52	16,1
250	75	120	80	2 ○	52	16	52	18,5
280	75	120	100	2 ○	53	14	53	21,1
300	75	120	85	2 x	51	18	51	23,5
315	75	125	90	2 x	52	16	52	25,4
355	75	125	90	2 x	51	18	51	31,2
400	85	135	100	2 x	51	18	51	33,2
450	85	135	100	2 x	51	18	51	38,8
500	85	140	105	2 x	51	18	51	44,0
560	85	145	105	2 x	51	18	51	51,3
630	85	145	115	2 x	51	18	51	61,5

- = Vollscheibe / solid pulley
- = Bodenschleibe (mit oder ohne Spiegel) / plate pulley (with or without holes)
- x = Armscheibe / arm pulley