

BRAKE MOTOR

90W

□90mm

K9□S90F□-B

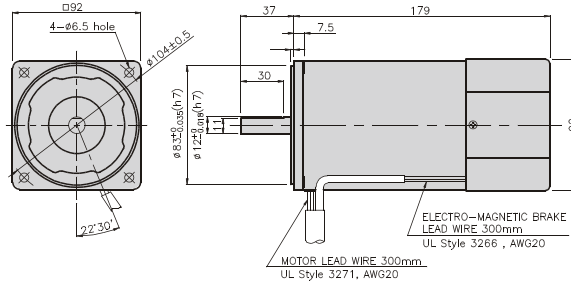

SPECIFICATIONS

90W single-phase : 30 minutes rating, three-phase : continuous rating, four poles

Model	Duty	Voltage (V)	Frequency (Hz)	Current (A)	Start T _s (N*m/Kgf*cm)	Rated T _r (N*m/Kgf*cm)	Speed (rpm)	Condenser (μF)	Friction T _f (N*m/Kgf*cm)		
K9R□90FJ-B K9R□90FU-B K9R□90FL-B K9R□90FC-B K9R□90FD-B	single-phase 30 minutes	100	50	2,52	0,6/6	0,705/7,05	1250	35	1/10		
			60	2,42			1550				
		K9R□90FU-B	110	60	1,88	0,55/5,5	0,57/5,7	1550	25	1/10	
					2,12						
		K9R□90FL-B	200	50	0,9	0,55/5,5	0,705/7,05	1250	8	1/10	
					1,1						
		K9R□90FC-B	220	50	1	0,5/5	0,705/7,05	1250	7	1/10	
					60						1,1
				230	50	1,3	0,6/6	0,705/7,05			1250
					60	1,1					
K9R□90FD-B	240	50	0,94	0,55/5,5	0,705/7,05	1250	6	1/10			
K9I□90FT-B	200	50	0,79	2,25/22,5	0,65/6,5	1350	-	1/10			
			60						0,72	1,75/17,5	0,55/5,5
K9I□90FH-B	220	50	0,72	2,35/23,5	0,65/6,5	1350	-	1/10			
			60						0,63	1,8/18	0,55/5,5
		230	50	0,86	2,45/24,5	0,65/6,5			1350		
			60	0,66						1,95/19,5	0,55/5,5
K9I□90FM-B	380	50	0,43	2,35/23,5	0,65/6,5	1350	-	1/10			
			60						0,37	1,7/17	0,55/5,5
K9I□90FV-B	400	50	0,52	2,65/26,5	0,65/6,5	1350	-	1/10			
			60						0,45	2,1/21	0,55/5,5
K9I□90FQ-B	415	50	0,39	2/20	0,68/6,8	1300	-	1/10			
			60						0,31	1,5/15	0,55/5,5
K9I□90FZ-B	440	50	0,45	2,1/21	0,68/6,8	1300	-	1/10			
			60						0,39	1,7/17	0,55/5,5

* □ : SHAFT SHAPE (S : STRAIGHT, G : PINION)

RATED TORQUE OF GEARHEAD

● 50Hz

unit = above : N · m / below : kgfcm

Model Motor/ Gearhead	Speed(rpm) Ratio	500	416	300	250	200	166	150	120	100	83	75	60	50	41	37	30	25	20	16	15	12,5	10	8,3	7,5	
		K9□P90F□-B K9P□B, BF		1,58	1,90	2,63	3,16	3,95	4,74	5,27	5,92	7,11	8,53	9,48	10,66	12,79	15,35	17,06	20	20	20	20	20	20	20	20
		15,8	19,0	26,3	31,6	39,5	47,4	52,7	59,2	71,1	85,3	94,8	106,6	127,9	153,5	170,6	200	200	200	200	200	200	200	200	200	200

● 60Hz

unit = above : N · m / below : kgfcm

Model Motor/ Gearhead	Speed(rpm) Ratio	600	500	360	300	240	200	180	144	120	100	90	72	60	50	45	36	30	24	20	18	15	12	10	9
		K9□P90F□-B K9P□B, BF		1,34	1,60	2,23	2,67	3,34	4,01	4,46	5,01	6,01	7,22	8,02	9,02	10,83	12,99	14,43	18,0	20	20	20	20	20	20
		13,4	16,0	22,3	26,7	33,4	40,1	44,6	50,1	60,1	72,2	80,2	90,2	108,3	129,9	144,3	180	200	200	200	200	200	200	200	200

* Gearhead and decimal gearhead are sold separately.

* The code in □ of gearhead model is for gear ratio.

* ■ color indicates that the output shaft of the geared motor rotates in the same direction as the output shaft of the motor. Others indicate rotation in the opposite direction.

* If you are to have less ratio than the ratio in the table, you can install the decimal gearhead, which has one tenth of the ratio, between the gearhead and the motor. In this case, the permissible torque is 20N · m/200kgfcm.

* RPM is based on motor's synchronous rpm (50HZ:1500rpm, 60HZ:1800rpm) and calculated by dividing gear ratio. Actual rpm is 2~20% less than indicating rpm according to load size.

GEARHEADS

RATED TORQUE OF GEARHEAD

● 50Hz

unit = above : N · m / below : kgfcm

Model	Speed(rpm)	500	416	300	250	200	166	150	120	100	82	75	60	50	41	37	30	25	20	16	15	13	10	8,3	7,5
Motor/ Gearhead	Ratio	3	3,6	5	6	7,5	9	10	12,5	15	18	20	25	30	36	40	50	60	75	90	100	120	150	180	200
K9□P90F□-B K9P□BU, BUF		1,58	1,90	2,63	3,16	3,95	4,74	5,27	5,92	7,11	8,53	9,48	10,66	12,79	15,35	17,06	21,32	25,59	30	30	30	30	30	30	30
		15,8	19,0	26,3	31,6	39,5	47,4	52,7	59,2	71,1	85,3	94,8	106,6	127,9	153,5	170,6	213,2	255,9	300	300	300	300	300	300	300

● 60Hz

unit = above : N · m / below : kgfcm

Model	Speed(rpm)	600	500	360	300	240	200	180	144	120	100	90	72	60	50	45	36	30	24	20	18	15	12	10	9
Motor/ Gearhead	Ratio	3	3,6	5	6	7,5	9	10	12,5	15	18	20	25	30	36	40	50	60	75	90	100	120	150	180	200
K9□P90F□-B K9P□BU, BUF		1,34	1,60	2,23	2,67	3,34	4,01	4,46	5,01	6,01	7,22	8,02	9,02	10,83	12,99	14,43	18,04	21,65	24,36	30	30	30	30	30	30
		13,4	16,0	22,3	26,7	33,4	40,1	44,6	50,1	60,1	72,2	80,2	90,2	108,3	129,9	144,3	180,4	216,5	243,6	300	300	300	300	300	300

- * Gearhead and decimal gearhead are sold separately.
- * The code in □ of gearhead model is for gear ratio.
- * ■ color indicates that the output shaft of the geared motor rotates in the same direction as the output shaft of the motor. Others indicate rotation in the opposite direction.
- * If you are to have less ratio than the ratio in the table, you can install the decimal gearhead, which has one tenth of the ratio, between the gearhead and the motor. In this case, the permissible torque is 30N · m/300kgfcm.
- * RPM is based on motor's synchronous rpm (50HZ:1500rpm, 60HZ:1800rpm) and calculated by dividing gear ratio. Actual rpm is 2~20% less than indicating rpm according to load size.

CONNECTION DIAGRAMS

single phase motor

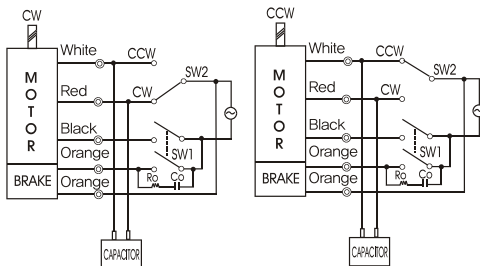

three phase motor

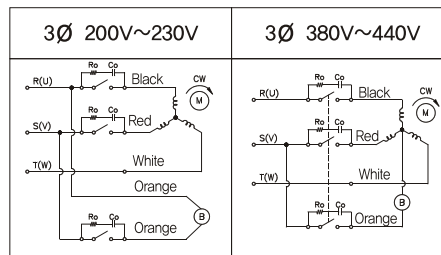

connecting two leadwires of U,V,W in turns

※The direction of motor rotation is as viewed from the front shaft end of the motor

Connect Cr circuit for absorbing surge voltage as connection diagram to protect contact point.
 $R_o = 5 - 200\Omega$
 $C_o = 0,1 \sim 0,2\mu F$ 200WV(400WV)

GEARHEADS

DIMENSIONS

K9P□B



K9P□BF, BUF



K9P□BU



DECIMAL GEARHEAD

K9P10BX

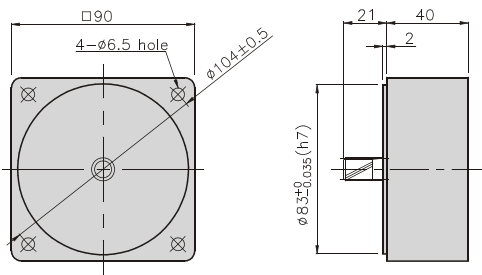

GEARHEAD

K9P□B

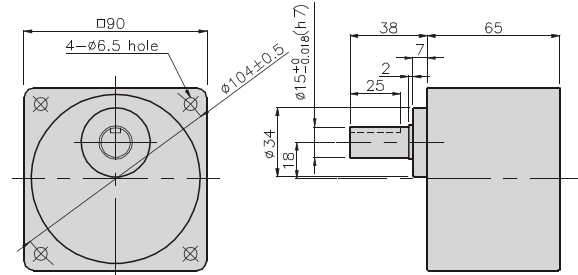

GEARHEAD

K9P□BF

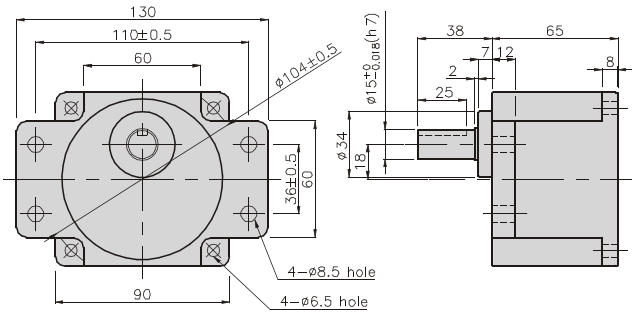

GEARHEAD

K9P□BU

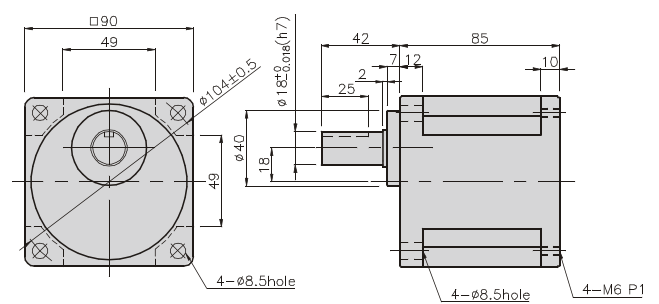

GEARHEAD

K9P□BUF

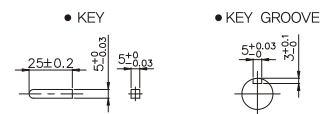
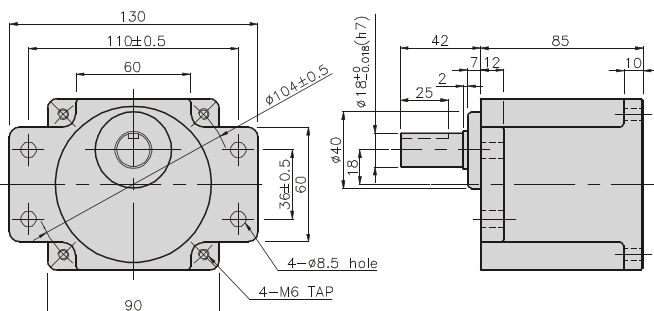

GEARHEADS

DIMENSIONS

K9□P90F□-B + K9P□B



K9□P90F-B + K9P□BF, BUF



K9□P90F□-B + K9P□BU



K9□P90F□-B + K9P□B

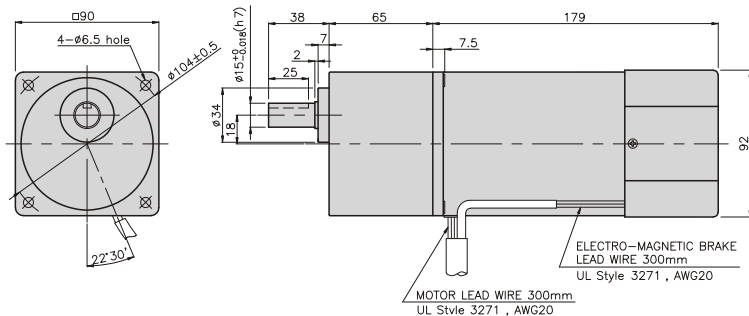

WEIGHT

PART	WEIGHT(kg)
MOTOR	3,60
DECIMAL GEAR HEAD	0,62

DIMENSION TABLE

PART No	L	Application Model	Mounting BOLT
01	65	K9P3~200B	M6 P1,0 X 95
02	40	K9P10BX	M6 P1,0 X 140

WEIGHT

PART	WEIGHT(kg)
K9P3~10B	1,22
K9P12,5~20B	1,32
K9P25~60B	1,42
K9P75~200B	1,45

K9□P90F-B + K9P□BF

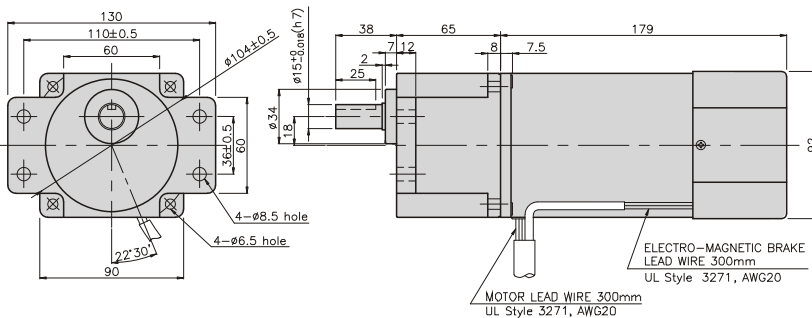

DIMENSION TABLE

PART No	L	Application Model	Mounting BOLT
01	65	K9P3~200BF	M6 P1,0 X 25
02	40	K9P10BX	M6 P1,0 X 65

WEIGHT

PART	WEIGHT(kg)
K9P3~10BF	1,22
K9P12,5~20BF	1,30
K9P25~60BF	1,42
K9P75~200BF	1,44

K9□P90F□-B + K9P□BU

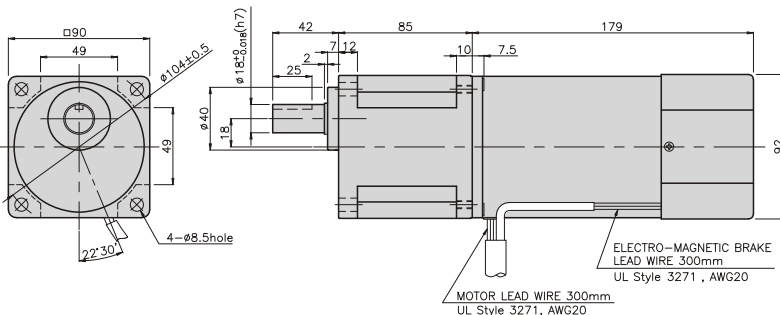

DIMENSION TABLE

PART No	L	Application Model	Mounting BOLT
01	85	K9P3~200BU	M6 P1,0 X 20
02	40	K9P10BX	M6 P1,0 X 60

WEIGHT

PART	WEIGHT(kg)
K9P3~10BU	1,44
K9P12,5~20BU	1,55
K9P25~60BU	1,69
K9P75~200BU	1,74

K9□P90F□-B + K9P□BUF

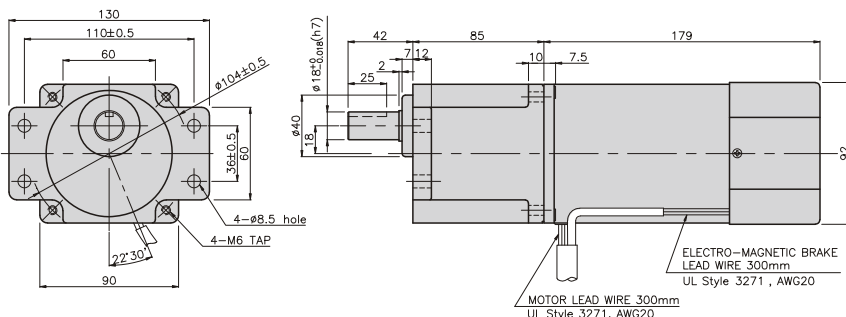

DIMENSION TABLE

PART No	L	Application Model	Mounting BOLT
01	85	K9P3~200BUF	M6 P1,0 X 20
02	40	K9P10BX	M6 P1,0 X 65

WEIGHT

PART	WEIGHT(kg)
K9P3~10BUF	1,50
K9P12,5~20BUF	1,62
K9P25~60BUF	1,76
K9P75~200BUF	1,82