

BRAKE MOTOR

6W

□ 60mm

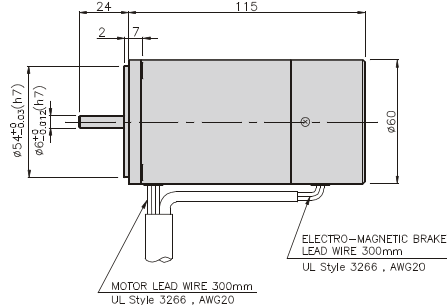
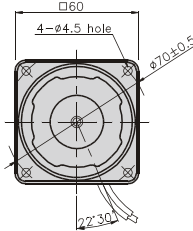

SPECIFICATIONS

6W 30 minutes rating, four poles

Model	Duty	Voltage (V)	Frequency (Hz)	Current (A)	Start T. (N*m/Kgf*cm)	Rated T. (N*m/Kgf*cm)	Speed (rpm)	Condenser (μF)	Friction T. (N*m/Kgf*cm)
K6R□6NJ-B	single-phase 30 minutes	100	50	0,25	0,035/0,35	0,049/0,49	1200	3	0,2/2
			60	0,23		0,04/0,4	1500		
K6R□6NU-B		110	60	0,2	0,045/0,45	0,04/0,4	1500	2,5	0,2/2
		115		0,2					
K6R□6NL-B		200	50	0,12	0,055/0,55	0,049/0,49	1200	1	0,2/2
			60	0,13		0,04/0,4	1500		
K6R□6NC-B		220	50	0,12	0,045/0,45	0,047/0,47	1250	0,8	0,2/2
			60	0,12		0,04/0,4	1500		
		230	50	0,15	0,055/0,55	0,047/0,47	1250		
			60	0,13	0,06/0,6	0,04/0,4	1500		
K6R□6ND-B	240	50	0,12	0,048/0,48	0,047/0,47	1250	0,6	0,2/2	

* □ : SHAFT SHAPE (S : STRAIGHT, G : PINION)

RATED TORQUE OF GEARHEAD

● 50Hz

unit = above : N · m / below : kgfcm

Model	Speed(rpm)	500	416	300	250	200	166	150	120	100	83	75	60	50	41	37	30	25	20	16	15	12,5	10	8,3	7,5	6
Motor/ Gearhead	Ratio	3	3,6	5	6	7,5	9	10	12,5	15	18	20	25	30	36	40	50	60	75	90	100	120	150	180	200	250
K6R□6N□-B K6G□B(C)	0,11	0,14	0,19	0,23	0,29	0,34	0,38	0,48	0,57	0,69	0,69	0,86	1,03	1,23	1,37	1,54	1,85	2,31	2,78	3	3	3	3	3	3	
	1,1	1,4	1,9	2,3	2,9	3,4	3,8	4,8	5,7	6,9	6,9	8,6	10,3	12,3	13,7	15,4	18,5	23,1	27,8	30	30	30	30	30	30	

● 60Hz

unit = above : N · m / below : kgfcm

Model	Speed(rpm)	600	500	360	300	240	200	180	144	120	100	90	72	60	50	45	36	30	24	20	18	15	12	10	9	7,2
Motor/ Gearhead	Ratio	3	3,6	5	6	7,5	9	10	12,5	15	18	20	25	30	36	40	50	60	75	90	100	120	150	180	200	250
K6R□6N□-B K6G□B(C)	0,10	0,12	0,16	0,19	0,24	0,29	0,32	0,41	0,49	0,58	0,58	0,73	0,87	1,05	1,17	1,31	1,57	1,97	2,36	2,62	3	3	3	3	3	
	1,0	1,2	1,6	1,9	2,4	2,9	3,2	4,1	4,9	5,8	5,8	7,3	8,7	10,5	11,7	13,1	15,7	19,7	23,6	26,2	30	30	30	30	30	

* Gearhead and decimal gearhead are sold separately.

* The code in □ of gearhead model is for gear ratio.

* ■ color indicates that the output shaft of the geared motor rotates in the same direction as the output shaft of the motor. Others indicate rotation in the opposite direction.

* If you are to have less ratio than the ratio in the table, you can install the decimal gearhead, which has one tenth of the ratio, between the gearhead and the motor. In this case, the permissible torque is 3N · m/30kgfcm.

* RPM is based on motor's synchronous rpm (50HZ:1500rpm, 60HZ:1800rpm) and calculated by dividing gear ratio. Actual rpm is 2~20% less than indicating rpm according to load size.

GEARHEADS

CONNECTION DIAGRAMS

Connect Cr circuit for absorbing surge voltage as connection diagram to protect contact point.
 $R_o = 5 - 200\Omega$
 $C_o = 0,1 \sim 0,2\mu F \text{ 200WV(400WV)}$

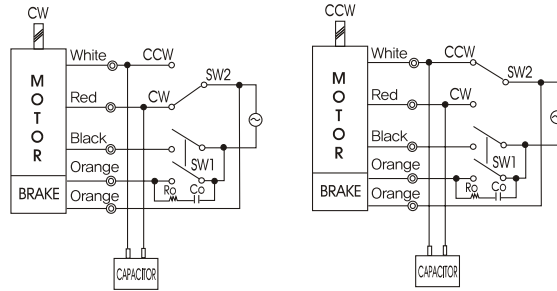

※The direction of motor rotation is as viewed from the front shaft end of the motor

DIMENSIONS

K6G□B(C)



K6RG6N□-B + K6G□B(C)



DECIMAL GEARHEAD

K6G10BX

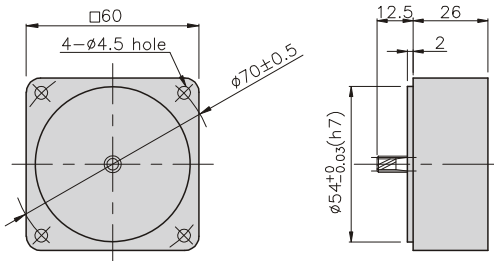

GEARHEAD

K6G□B(C)

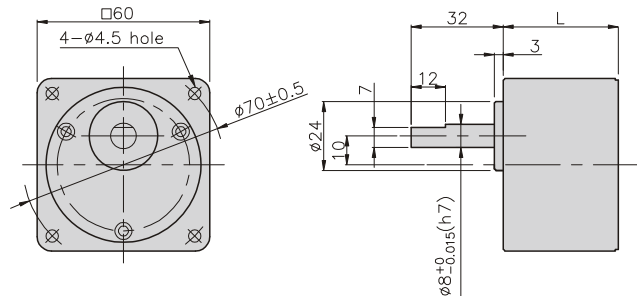

DIMENSION TABLE

PART No	L	Application Model	Mounting BOLT
01	30	K6G3~18B(C)	M4 P0,7 X 50
02	40	K6G20~250B(C)	M4 P0,7 X 60
03	26	K6G10BX	M4 P0,7 X 85

WEIGHT

PART	WEIGHT(kg)	
MOTOR	0,93	
DECIMAL GEAR HEAD	0,22	
GEAR HEAD	K6G3~18B(C)	0,26
	K6G30~40B(C)	0,33
	K6G50~250B(C)	0,36

K6RG6N□-B + K6G□B(C)

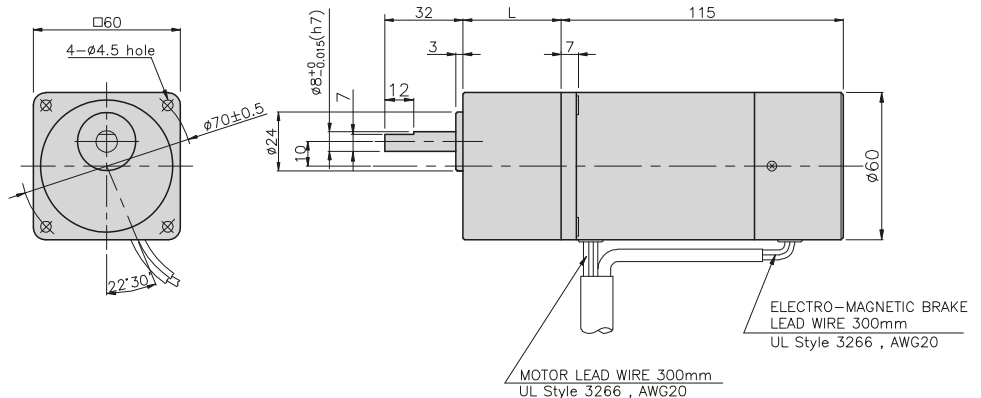

INDUCTION MOTOR

6W

□ 60mm

LEAD WIRE TYPE TERMINAL BOX TYPE

K6IS6N□



K6IS6N□-T



SPECIFICATIONS

6W continuous rating, four poles

Model		Voltage (V)	Frequency (Hz)	Current (A)	Start T. (N·m/Kgf·Cm)	Rated T. (N·m/Kgf·Cm)	Speed (rpm)	Condenser (μF)
K6I□6NJ(-T)		single-phase	100	50	0,25	0,04/0,4	0,049/0,49	1200
	60			0,23	0,04/0,4		1500	
K6I□6NU(-T)	110		60	0,18	0,035/0,35	0,04/0,4	1500	2
	115			0,19	0,04/0,4			
K6I□6NL(-T)	200		50	0,11	0,045/0,45	0,049/0,49	1200	0,8
			60			0,04/0,4	1500	
K6I□6NC(-T)	220		50	0,11	0,04/0,4	0,047/0,47	1250	0,6
			60	0,1	0,035/0,35	0,04/0,4	1500	
	230		50	0,12	0,045/0,45	0,047/0,47	1250	
			60	0,11	0,04/0,4	0,04/0,4	1500	
K6I□6ND(-T)	240		50	0,12	0,045/0,45	0,047/0,47	1250	0,5

* □ : SHAFT SHAPE (S : STRAIGHT, G : PINION)

RATED TORQUE OF GEARHEAD

● 50Hz

unit = above : N·m / below : kgfcm

Model Motor/ Gearhead	Speed(rpm)	500	416	300	250	200	166	150	120	100	83	75	60	50	41	37	30	25	20	16	15	12,5	10	8,3	7,5	6
	Ratio	3	3,6	5	6	7,5	9	10	12,5	15	18	20	25	30	36	40	50	60	75	90	100	120	150	180	200	250
K6I□6N□(-T) K6G□B(C)	0,11	0,14	0,19	0,23	0,29	0,34	0,38	0,48	0,57	0,69	0,69	0,86	1,03	1,23	1,37	1,54	1,85	2,31	2,78	3	3	3	3	3	3	3
	1,1	1,4	1,9	2,3	2,9	3,4	3,8	4,8	5,7	6,9	6,9	8,6	10,3	12,3	13,7	15,4	18,5	23,1	27,8	30	30	30	30	30	30	30

● 60Hz

unit = above : N·m / below : kgfcm

Model Motor/ Gearhead	Speed(rpm)	600	500	360	300	240	200	180	144	120	100	90	72	60	50	45	36	30	24	20	18	15	12	10	9	7,2
	Ratio	3	3,6	5	6	7,5	9	10	12,5	15	18	20	25	30	36	40	50	60	75	90	100	120	150	180	200	250
K6I□6N□(-T) K6G□B(C)	0,10	0,12	0,16	1,19	0,24	0,29	0,32	0,41	0,49	0,58	0,58	0,73	0,87	1,05	1,17	1,31	1,57	1,97	2,36	2,62	3	3	3	3	3	3
	1,0	1,2	1,6	1,9	2,4	2,9	3,2	4,1	4,9	5,8	5,8	7,3	8,7	10,5	11,7	13,1	15,7	19,7	23,6	26,2	30	30	30	30	30	30

* Gearhead and decimal gearhead are sold separately.

* The code in □ of gearhead model is for gear ratio.

* color indicates that the output shaft of the geared motor rotates in the same direction as the output shaft of the motor. Others indicate rotation in the opposite direction.

* If you are to have less ratio than the ratio in the table, you can install the decimal gearhead, which has one tenth of the ratio, between the gearhead and the motor. In this case, the permissible torque is 3N·m/30kgfcm.

* RPM is based on motor's synchronous rpm (50HZ:1500rpm, 60HZ:1800rpm) and calculated by dividing gear ratio. Actual rpm is 2~20% less than indicating rpm according to load size.

GEARHEADS

DIMENSIONS

K6IS6N□

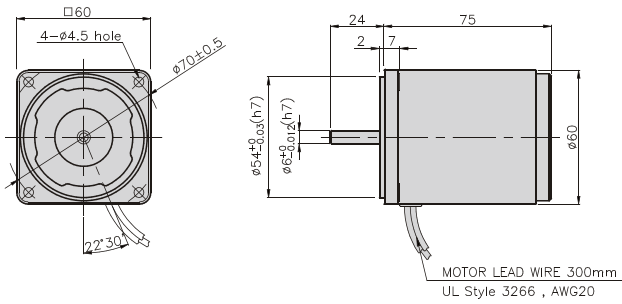

K6IS6N□-T

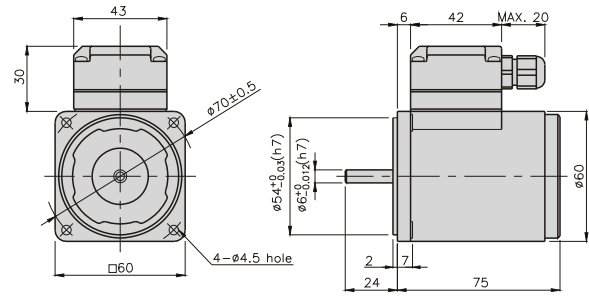

CONNECTION DIAGRAMS

K6IS6N□

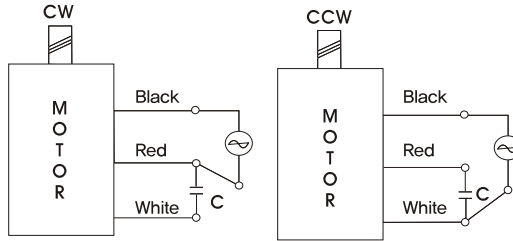

The direction of motor rotation is as viewed from the front shaft end of the motor

K6IS6N□-T

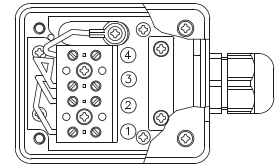
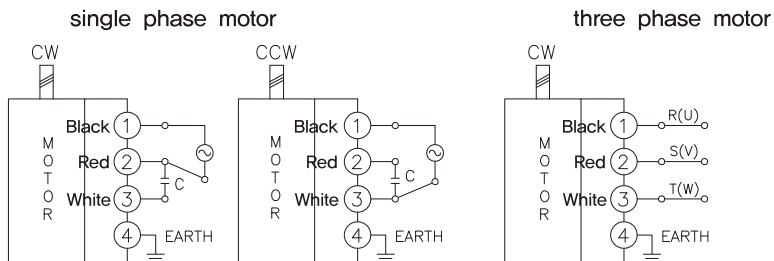

The direction of motor rotation is as viewed from the front shaft end of the motor

DIMENSIONS

K6G□B(C)



DECIMAL GEARHEAD

K6G10BX□

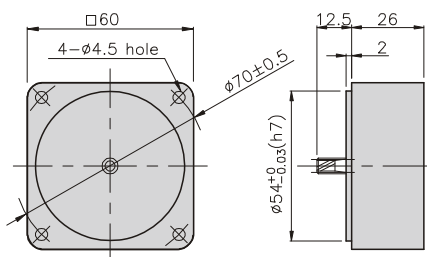

GEARHEAD

K6G□B(C)

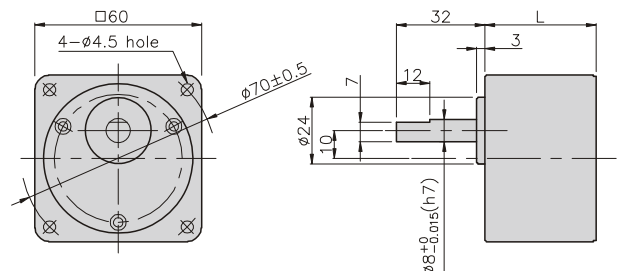

GEARHEADS

DIMENSIONS

K6IG6N□ + K6G□B(C)



K6IG6N□-T + K6G□B(C)



K6IG6N□ + K6G□B(C)

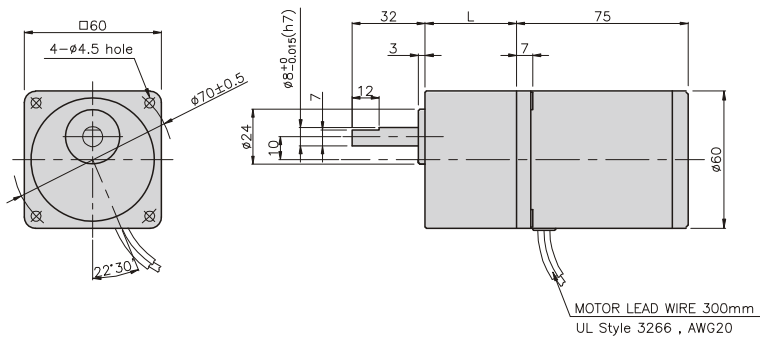

DIMENSION TABLE

PART No	L	Application Model	Mounting BOLT
01	30	K6G3~18B(C)	M4 P0,7 X 50
02	40	K6G20~250B(C)	M4 P0,7 X 60
03	26	K6G10BX	M4 P0,7 X 85

WEIGHT

PART	WEIGHT(kg)	
MOTOR	0,72	
DECIMAL GEAR HEAD	0,22	
GEAR HEAD	K6G3~18B(C)	0,26
	K6G20~40B(C)	0,33
	K6G50~250B(C)	0,36

K6IG6N□-T + K6G□B(C)

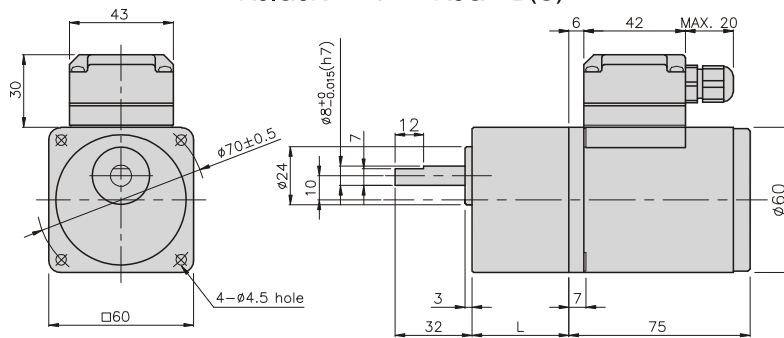

DIMENSION TABLE

PART No	L	Application Model	Mounting BOLT
01	30	K6G3~18B(C)	M4 P0,7 X 50
02	40	K6G20~250B(C)	M4 P0,7 X 60
03	26	K6G10BX	M4 P0,7 X 85

WEIGHT

PART	WEIGHT(kg)	
MOTOR	0,76	
DECIMAL GEAR HEAD	0,22	
GEAR HEAD	K6G3~18B(C)	0,26
	K6G20~40B(C)	0,33
	K6G50~250B(C)	0,36

REVERSIBLE MOTOR

6W

□ 60mm

LEAD WIRE TYPE TERMINAL BOX TYPE

K6RS6N□



K6RS6N□-T



SPECIFICATIONS

6W continuous rating, four poles

Model		Voltage (V)	Frequency (Hz)	Current (A)	Start T. (N*m/Kgf*cm)	Rated T. (N*m/Kgf*cm)	Speed (rpm)	Condenser (μF)
K6R□6NJ(-T)	single-phase	100	50	0,25	0,035/0,35	0,049/0,49	1200	3
			60	0,23		0,04/0,4	1500	
K6R□6NU(-T)	single-phase	110	60	0,2	0,045/0,45	0,04/0,4	1500	2,5
		115		0,2				
K6R□6NL(-T)	single-phase	200	50	0,12	0,055/0,55	0,049/0,49	1200	1
			60	0,13		0,04/0,4	1500	
K6R□6NC(-T)	single-phase	220	50	0,12	0,045/0,45	0,047/0,47	1250	0,8
			60	0,12		0,04/0,4	1500	
		230	50	0,15	0,055/0,55	0,047/0,47	1250	
			60	0,13	0,06/0,6	0,04/0,4	1500	
K6R□6ND(-T)	single-phase	240	50	0,12	0,048/0,48	0,047/0,47	1250	0,6

RATED TORQUE OF GEARHEAD

● 50Hz

unit = above : N · m / below : kgfcm

Model	Speed(rpm)	500	416	300	250	200	166	150	120	100	83	75	60	50	41	37	30	25	20	16	15	12,5	10	8,3	7,5	6
Motor/ Gearhead	Ratio	3	3,6	5	6	7,5	9	10	12,5	15	18	20	25	30	36	40	50	60	75	90	100	120	150	180	200	250
K6R□6N□(-T)		0,11	0,14	0,19	0,23	0,29	0,34	0,38	0,48	0,57	0,69	0,69	0,86	1,03	1,23	1,37	1,54	1,85	2,31	2,78	3	3	3	3	3	3
K6G□B(C)		1,1	1,4	1,9	2,3	2,9	3,4	3,8	4,8	5,7	6,9	6,9	8,6	10,3	12,3	13,7	15,4	18,5	21,3	27,8	30	30	30	30	30	30

● 60Hz

unit = above : N · m / below : kgfcm

Model	Speed(rpm)	600	500	360	300	240	200	180	144	120	100	90	72	60	50	45	36	30	24	20	18	15	12	10	9	7,2
Motor/ Gearhead	Ratio	3	3,6	5	6	7,5	9	10	12,5	15	18	20	25	30	36	40	50	60	75	90	100	120	150	180	200	250
K6R□6N□(-T)		0,10	0,12	0,16	0,19	0,24	0,29	0,32	0,41	0,49	0,58	0,58	0,73	0,87	1,05	1,17	1,31	1,57	1,97	2,36	2,62	3	3	3	3	3
K6G□B(C)		1,0	1,2	1,6	1,9	2,4	2,9	3,2	4,1	4,9	5,8	5,8	7,3	8,7	10,5	11,7	13,1	15,7	19,7	23,6	26,2	30	30	30	30	30

- * Gearhead and decimal gearhead are sold separately.
- * The code in □ of gearhead model is for gear ratio.
- * color indicates that the output shaft of the geared motor rotates in the same direction as the output shaft of the motor. Others indicate rotation in the opposite direction.
- * If you are to have less ratio than the ratio in the table, you can install the decimal gearhead, which has one tenth of the ratio, between the gearhead and the motor. In this case, the permissible torque is 3N · m/30kgfcm.
- * RPM is based on motor's synchronous rpm (50HZ:1500rpm, 60HZ:1800rpm) and calculated by dividing gear ratio. Actual rpm is 2~20% less than indicating rpm according to load size.

GEARHEADS

DIMENSIONS

K6RS6N □

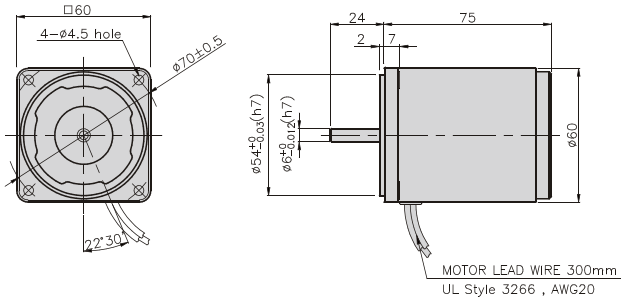

K6RS6N □-T

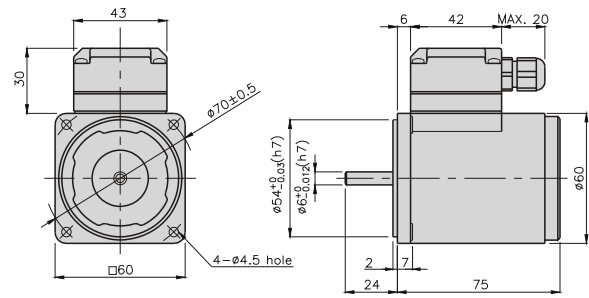

CONNECTION DIAGRAMS

K6RS6N □

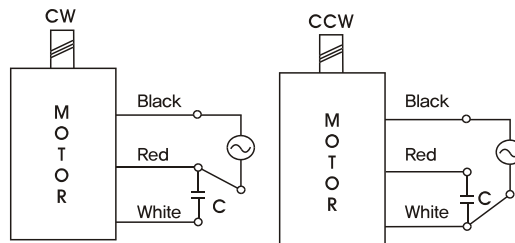

The direction of motor rotation is as viewed from the front shaft end of the motor

K6RS6N □-T

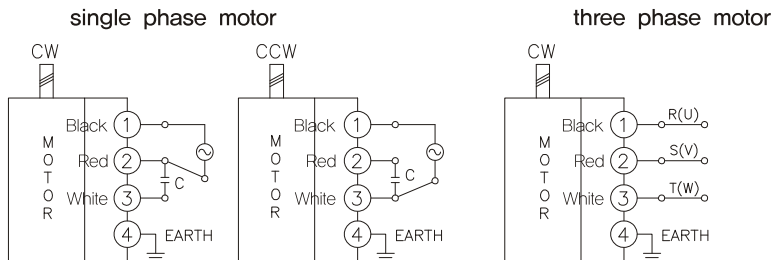

The direction of motor rotation is as viewed from the front shaft end of the motor

DIMENSIONS

K6G □(C)



DECIMAL GEARHEAD

K6G10BX □

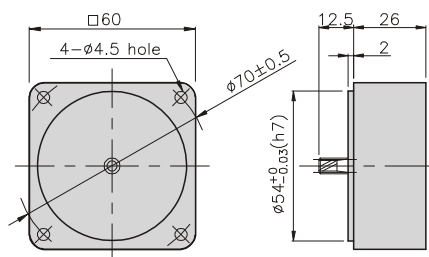

GEARHEAD

K6G □(C)

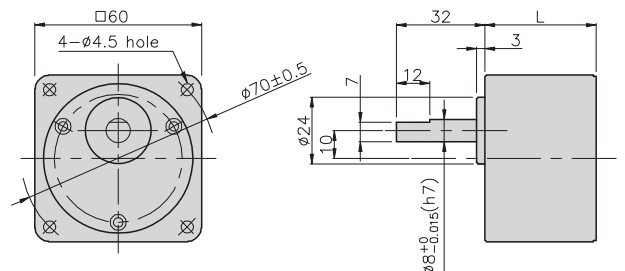

GEARHEADS

DIMENSIONS

K6RG6N□ + K6G□B(C)



K6RG6N□-T + K6G□B(C)



K6RG6N□ + K6G□B(C)

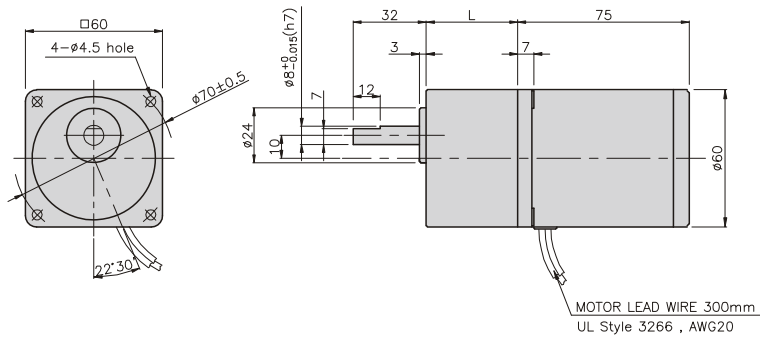

DIMENSION TABLE

PART No	L	Application Model	Mounting BOLT
01	30	K6G3~18B(C)	M4 P0,7 X 50
02	40	K6G20~250B(C)	M4 P0,7 X 60
03	26	K6G10BX	M4 P0,7 X 85

WEIGHT

PART	WEIGHT(kg)	
MOTOR	0,72	
DECIMAL GEAR HEAD	0,22	
GEAR HEAD	K6G3~18B(C)	0,26
	K6G20~40B(C)	0,33
	K6G50~250B(C)	0,36

K6RG6N□-T + K6G□B(C)

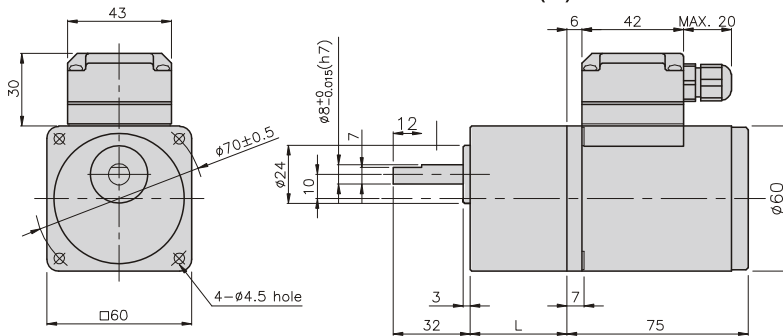

DIMENSION TABLE

PART No	L	Application Model	Mounting BOLT
01	30	K6G3~18B(C)	M4 P0,7 X 50
02	40	K6G20~250B(C)	M4 P0,7 X 60
03	26	K6G10BX	M4 P0,7 X 85

WEIGHT

PART	WEIGHT(kg)	
MOTOR	0,76	
DECIMAL GEAR HEAD	0,22	
GEAR HEAD	K6G3~18B(C)	0,26
	K6G20~40B(C)	0,33
	K6G50~250B(C)	0,36

SPEED CONTROL & BRAKE MOTOR

6W

□60mm

K6RS6N□-D

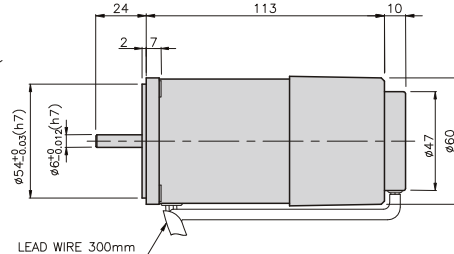
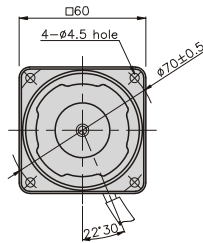

SPECIFICATIONS

6W 30 minutes rating, four poles

Model	Voltage (V)	Frequency (Hz)	Speed Range (rpm)	Permissible Torque		Start T. (N*m/ Kgf*cm)	Current (A)	Condenser (μF)	Friction T. (N*m/ Kgf*cm)
				1200rpm (N*m/ Kgf*cm)	90rpm (N*m/ Kgf*cm)				
K6R□6NJ-D	100	50	90 ~ 1400	0,052/0,52	0,035/0,35	0,027/0,27	0,28	3	0,2/2
			90 ~ 1700						
K6R□6NU-D	110	60	90 ~ 1700	0,052/0,52	0,035/0,35	0,035/0,35	0,32	2,5	0,2/2
	115								
K6R□6NL-D	200	50	90 ~ 1400	0,06/0,6	0,038/0,38	0,037/0,37	0,2	1	0,2/2
		60	90 ~ 1700						
K6R□6NC-D	220	50	90 ~ 1400	0,052/0,52	0,03/0,3	0,035/0,35	0,2	0,8	0,2/2
		60	90 ~ 1700			0,033/0,33			
	230	50	90 ~ 1400	0,06/0,6	0,038/0,38	0,035/0,35			
		60	90 ~ 1700			0,033/0,33			
K6R□6ND-D	240	50	90 ~ 1400	0,052/0,52	0,03/0,3	0,035/0,35	0,22	0,6	0,2/2

* □ : SHAFT SHAPE (S : STRAIGHT, G : PINION)

RATED TORQUE OF GEARHEAD

● Single-phase 100V/115V

unit = above : N · m / below : kgfcm

Model	Ratio	Speed(rpm)																								
		3	3,6	5	6	7,5	9	10	12,5	15	18	20	25	30	36	40	50	60	75	90	100	120	150	180	200	250
K6R□6N□-D K6G□B(C)	1200	0,13 1,3	0,15 1,5	0,21 2,1	0,25 2,5	0,32 3,2	0,38 3,8	0,42 4,2	0,53 5,3	0,63 6,3	0,76 7,6	0,76 7,6	0,95 9,5	1,14 11,4	1,36 13,6	1,52 15,2	1,71 17,1	2,05 20,5	2,56 25,6	3 30	3 30	3 30	3 30	3 30	3 30	3 30
	90	0,09 0,9	0,10 1,0	0,14 1,4	0,17 1,7	0,21 2,1	0,26 2,6	0,28 2,8	0,35 3,5	0,43 4,3	0,51 5,1	0,51 5,1	0,64 6,4	0,77 7,7	0,92 9,2	1,02 10,2	1,15 11,5	1,38 13,8	1,72 17,2	2,07 20,7	2,30 23,0	2,76 27,6	3 30	3 30	3 30	3 30

● Single-phase 200V/240V

unit = above : N · m / below : kgfcm

Model	Ratio	Speed(rpm)																									
		3	3,6	5	6	7,5	9	10	12,5	15	18	20	25	30	36	40	50	60	75	90	100	120	150	180	200	250	
K6R□6N□-D K6G□B(C)	1200	200V/230V 50Hz/60Hz	0,15 1,5	0,17 1,7	0,24 2,4	0,29 2,9	0,36 3,6	0,44 4,4	0,49 4,9	0,61 6,1	0,73 7,3	0,87 8,7	0,87 8,7	1,09 10,9	1,31 13,1	1,57 15,7	1,75 17,5	1,97 19,7	2,36 23,6	2,95 29,5	3 30	3 30	3 30	3 30	3 30	3 30	3 30
		220V/150Hz/60Hz 240V/50Hz	0,13 1,3	0,15 1,5	0,21 2,1	0,25 2,5	0,32 3,2	0,38 3,8	0,42 4,2	0,53 5,3	0,63 6,3	0,76 7,6	0,76 7,6	0,95 9,5	1,14 11,4	1,36 13,6	1,52 15,2	1,71 17,1	2,05 20,5	2,56 25,6	3 30	3 30	3 30	3 30	3 30	3 30	3 30
	90	200V/230V 50Hz/60Hz	0,09 0,9	0,11 1,1	0,15 1,5	0,18 1,8	0,23 2,3	0,28 2,8	0,31 3,1	0,38 3,8	0,46 4,6	0,55 5,5	0,55 5,5	0,69 6,9	0,83 8,3	1,00 10,0	1,11 11,1	1,25 12,5	1,50 15,0	1,87 18,7	2,24 22,4	2,49 24,9	2,99 29,9	3 30	3 30	3 30	3 30
		220V/150Hz/60Hz 240V/50Hz	0,07 0,7	0,09 0,9	0,12 1,2	0,15 1,5	0,18 1,8	0,22 2,2	0,24 2,4	0,30 3,0	0,36 3,6	0,44 4,4	0,44 4,4	0,55 5,5	0,66 6,6	0,79 7,9	0,87 8,7	0,98 9,8	1,18 11,8	1,48 14,8	1,77 17,7	1,97 19,7	2,36 23,6	2,95 29,5	3 30	3 30	3 30

* Gearhead and decimal gearhead are sold separately.

* The code in □ of gearhead model is for gear ratio.

* ■ color indicates that the output shaft of the geared motor rotates in the same direction as the output shaft of the motor. Others indicate rotation in the opposite direction.

* If you are to have less ratio than the ratio in the table, you can install the decimal gearhead, which has one tenth of the ratio, between the gearhead and the motor. In this case, the permissible torque is 3N · m/30kgfcm.

* RPM is based on motor's synchronous rpm (50HZ:1500rpm, 60HZ:1800rpm) and calculated by dividing gear ratio. Actual rpm is 2~20% less than indicating rpm according to load size.

GEARHEADS

CONNECTION DIAGRAMS

Connect Cr circuit for absorbing surge voltage as connection diagram to protect contact point,
 $R_o = 5 - 200\Omega$
 $C_o = 0,1 \sim 0,2\mu F$ 200WV(400WV)

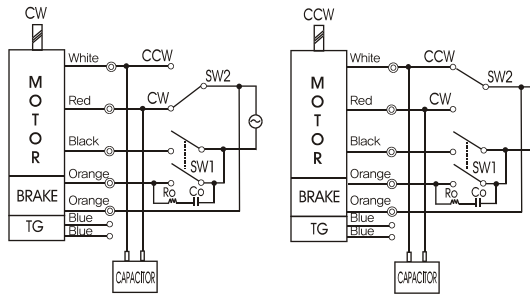

※The direction of motor rotation is as viewed from the front shaft end of the motor

DIMENSIONS

K6G□B(C)



K6RG6N□-D + K6G□B(C)



DECIMAL GEARHEAD

K6G10BX

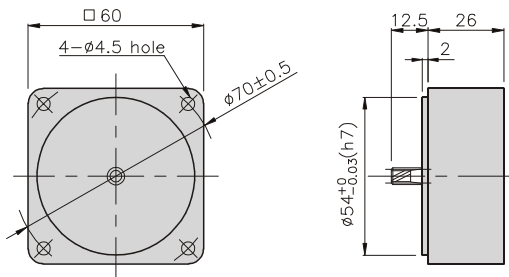

GEARHEAD

K6G□B(C)

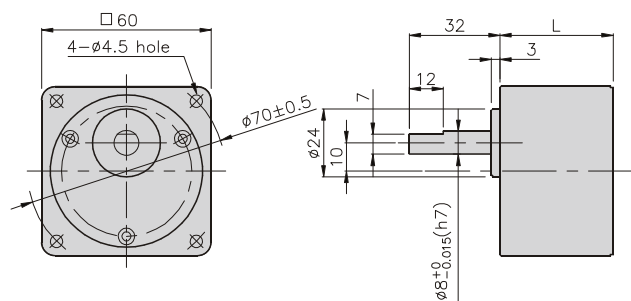

DIMENSION TABLE

PART No.	L	Application Model	Mounting BOLT
01	30	K6G3~18B(C)	M4 P0,7 X 50
02	40	K6G20~250B(C)	M4 P0,7 X 60
03	26	K6G10BX	M4 P0,7 X 85

WEIGHT

PART	WEIGHT(kg)	
MOTOR	1,00	
DECIMAL GEAR HEAD	0,22	
GEAR HEAD	K6G3~18B(C)	0,26
	K6G20~40B(C)	0,33
	K6G60~250B(C)	0,36

K6RG6N□-D + K6G□B(C)

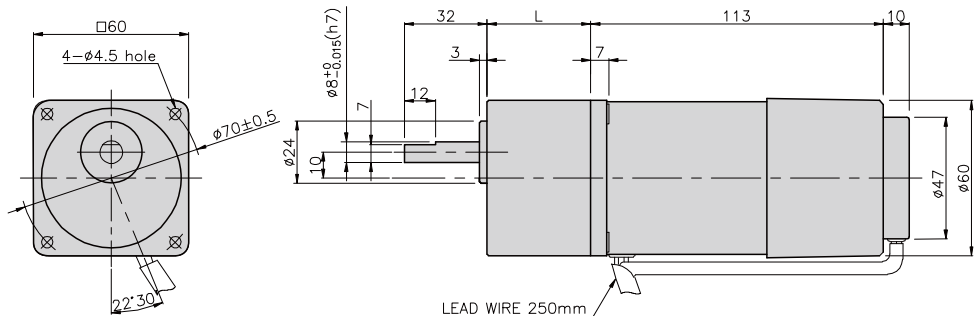

SPEED CONTROL MOTOR - SP SERIES

6W

□60mm

INDUCTION MOTOR

K6IS6N□-SP

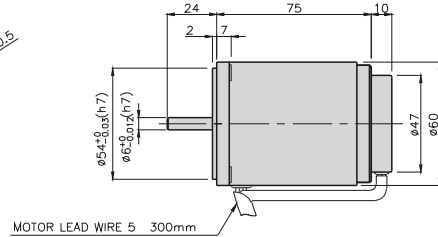
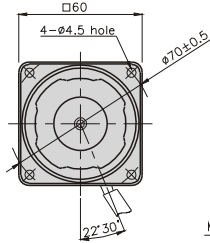

SPECIFICATIONS

6W continuous rating, four poles

Model	Voltage(V)	Frequency (Hz)	Speed Range (rpm)	Permissible Torque		Start T. (N*m/Kgf*cm)	Current (A)	Condenser (μF)
				1200rpm (N*m/kgf*cm)	90rpm (N*m/kgf*cm)			
K6I□6NJ-SP	100	50	90 ~ 1400	0,05/0,5	0,03/0,3	0,029/0,29	0,28	3
		60	90 ~ 1700					
K6I□6NU-SP	110	60	90 ~ 1700	0,05/0,5	0,03/0,3	0,03/0,3	0,24	2
	115							
K6I□6NL-SP	200	50	90 ~ 1400	0,05/0,5	0,029/0,29	0,03/0,3	0,19	0,8
		60	90 ~ 1700					
K6I□6NC-SP	220	50	90 ~ 1400	0,05/0,5	0,029/0,29	0,03/0,3	0,2	0,6
		60	90 ~ 1700					
		50	90 ~ 1400					
		60	90 ~ 1700					
K6I□6ND-SP	240	50	90 ~ 1400	0,05/0,5	0,029/0,29	0,03/0,3	0,21	0,5

* □ : SHAFT SHAPE (S : STRAIGHT, G : PINION)

RATED TORQUE OF GEARHEAD

● Single-phase 100V/115V

unit = above : N·m / below : kgfcm

Model	Ratio	Speed(rpm)																								
		3	3,6	5	6	7,5	9	10	12,5	15	18	20	25	30	36	40	50	60	75	90	100	120	150	180	200	250
K6I□6N□-SP K6G□B(C)	1200	0,12 1,2	0,15 1,5	0,20 2,0	0,24 2,4	0,30 3,0	0,36 3,6	0,41 4,1	0,51 5,1	0,61 6,1	0,73 7,3	0,73 7,3	0,91 9,1	1,09 10,9	1,31 13,1	1,46 14,6	1,64 16,4	1,97 19,7	2,46 24,6	2,95 29,5	3 30	3 30	3 30	3 30	3 30	3 30
	90	0,07 0,7	0,08 0,8	0,12 1,2	0,14 1,4	0,18 1,8	0,21 2,1	0,23 2,3	0,26 2,6	0,32 3,2	0,42 4,2	0,42 4,2	0,53 5,3	0,63 6,3	0,76 7,6	0,85 8,5	0,95 9,5	1,14 11,4	1,43 14,3	1,71 17,1	1,90 19,0	2,28 22,8	2,85 28,5	3 30	3 30	3 30

● Single-phase 200V/240V

unit = above : N·m / below : kgfcm

Model	Ratio	Speed(rpm)																								
		3	3,6	5	6	7,5	9	10	12,5	15	18	20	25	30	36	40	50	60	75	90	100	120	150	180	200	250
K6I□6N□-SP K6G□B(C)	1200	0,12 1,2	0,15 1,5	0,20 2,0	0,24 2,4	0,30 3,0	0,36 3,6	0,41 4,1	0,51 5,1	0,61 6,1	0,73 7,3	0,73 7,3	0,91 9,1	1,09 10,9	1,31 13,1	1,46 14,6	1,64 16,4	1,97 19,7	2,46 24,6	2,95 29,5	3 30	3 30	3 30	3 30	3 30	3 30
	90	0,07 0,7	0,08 0,8	0,12 1,2	0,14 1,4	0,18 1,8	0,21 2,1	0,23 2,3	0,29 2,9	0,35 3,5	0,42 4,2	0,42 4,2	0,53 5,3	0,63 6,3	0,76 7,6	0,85 8,5	0,95 9,5	1,14 11,4	1,43 14,3	1,71 17,1	1,90 19,0	2,28 22,8	2,85 28,5	3 30	3 30	3 30

- * Gearhead and decimal gearhead are sold separately.
- * The code in □ of gearhead model is for gear ratio.
- * color indicates that the output shaft of the geared motor rotates in the same direction as the output shaft of the motor. Others indicate rotation in the opposite direction.
- * If you are to have less ratio than the ratio in the table, you can install the decimal gearhead, which has one tenth of the ratio, between the gearhead and the motor. In this case, the permissible torque is 3N·m/30kgfcm.
- * RPM is based on motor's synchronous rpm (50HZ:1500rpm, 60HZ:1800rpm) and calculated by dividing gear ratio. Actual rpm is 2~20% less than indicating rpm according to load size.

GEARHEADS

CONNECTION DIAGRAMS

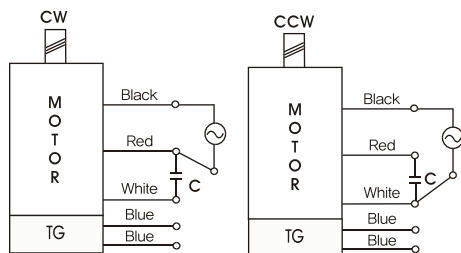

※The direction of motor rotation is as viewed from the front shaft end of the motor

DIMENSIONS

K6G□B(C)



K6IG6N□-SP + K6G□B(C)



DECIMAL GEARHEAD

K6G10BX

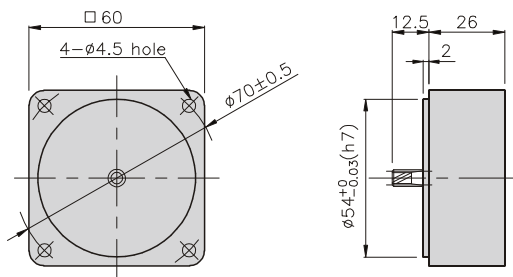

GEARHEAD

K6G□B(C)

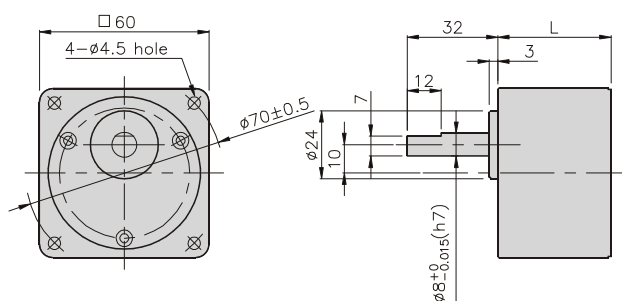

DIMENSION TABLE

PART No.	L	Application Model	Mounting BOLT
01	30	K6G3~18B(C)	M4 P0,7 X 50
02	40	K6G20~250B(C)	M4 P0,7 X 60
03	26	K6G10BX	M4 P0,7 X 85

WEIGHT

PART	WEIGHT(kg)	
MOTOR	0.79	
DECIMAL GEAR HEAD	0.22	
GEAR HEAD	K6G3~18B(C)	0.26
	K6G20~40B(C)	0.33
	K6G60~250B(C)	0.36

K6IG6N□-SP + K6G□B(C)

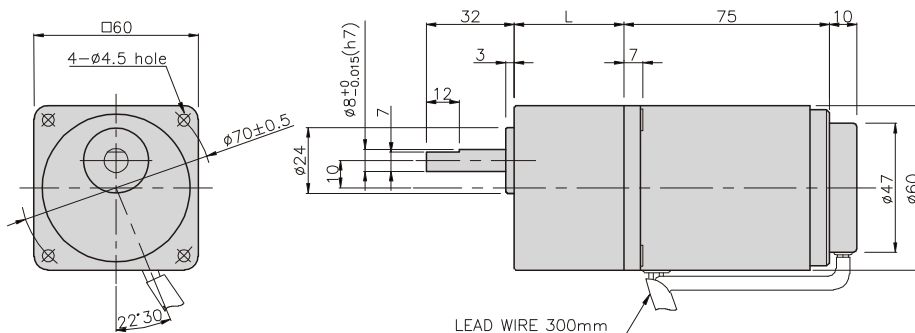

SPEED CONTROL MOTOR - SP SERIES

6W

□90mm

REVERSIBLE MOTOR

K6RS6N□-SP

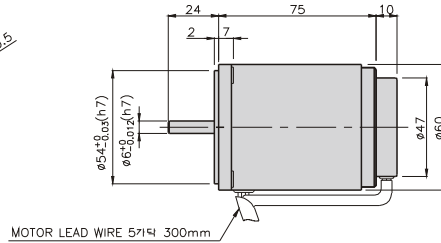
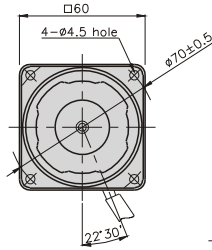

SPECIFICATIONS

6W 30 minutes rating, four poles

Model	Voltage (V)	Frequency (Hz)	Speed Range (rpm)	Permissible Torque		Start T. (N*m/Kgf*cm)	Current (A)	Condenser (μF)
				1200rpm (N*m/kgf*cm)	90rpm (N*m/kgf*cm)			
K6R□6NJ-SP	100	50	90 ~ 1400	0,052/0,52	0,035/0,35	0,027/027	0,28	3
			90 ~ 1700					
K6R□6NU-SP	110	60	90 ~ 1700	0,052/0,52	0,035/0,35	0,035/0,35	0,32	2,5
			115					
K6R□6NL-SP	200	50	90 ~ 1400	0,06/0,6	0,038/0,38	0,037/0,37	0,2	1
			90 ~ 1700					
K6R□6NC-SP	220	50	90 ~ 1400	0,052/0,52	0,03/0,3	0,035/0,35	0,2	0,8
			90 ~ 1700			0,033/0,33		
		50	90 ~ 1400	0,06/0,6	0,038/0,38	0,035/0,35	0,2	
			90 ~ 1700			0,033/0,33		
K6R□6ND-SP	240	50	90 ~ 1400	0,052/0,52	0,03/0,3	0,035/0,35	0,22	0,6
			90 ~ 1700					

* □ : SHAFT SHAPE (S : STRAIGHT, G : PINION)

RATED TORQUE OF GEARHEAD

● Single-phase 100V/115V

unit = above : N · m / below : kgfcm

Model	Ratio	Speed(rpm)																									
		3	3,6	5	6	7,5	9	10	12,5	15	18	20	25	30	36	40	50	60	75	90	100	120	150	180	200	250	
K6R□6N□-SP K6G□B(C)	1200	0,13 1,3	0,15 1,5	0,21 2,1	0,25 2,5	0,32 3,2	0,38 3,8	0,42 4,2	0,53 5,3	0,63 6,3	0,76 7,6	0,76 7,6	0,95 9,5	1,14 11,4	1,36 13,6	1,52 15,2	1,71 17,1	2,05 20,5	2,56 25,6	3 30	3 30	3 30	3 30	3 30	3 30	3 30	3 30
	90	0,09 0,9	0,10 1,0	0,14 1,4	0,17 1,7	0,21 2,1	0,26 2,6	0,28 2,8	0,35 3,5	0,43 4,3	0,51 5,1	0,51 5,1	0,64 6,4	0,77 7,7	0,92 9,2	1,02 10,2	1,15 11,5	1,38 13,8	1,72 17,2	2,07 20,7	2,30 23,0	2,76 27,6	3 30	3 30	3 30	3 30	3 30

● Single-phase 200V/240V

unit = above : N · m / below : kgfcm

Model	Ratio	Speed(rpm)																									
		3	3,6	5	6	7,5	9	10	12,5	15	18	20	25	30	36	40	50	60	75	90	100	120	150	180	200	250	
K6R□6N□-SP K6G□B(C)	1200	200V/230V 50Hz/60Hz	0,15 1,5	0,17 1,7	0,24 2,4	0,29 2,9	0,36 3,6	0,44 4,4	0,49 4,9	0,61 6,1	0,73 7,3	0,87 8,7	0,87 8,7	1,09 10,9	1,31 13,1	1,57 15,7	1,75 17,5	1,97 19,7	2,36 23,6	2,95 29,5	3 30	3 30	3 30	3 30	3 30	3 30	3 30
		220V/50Hz/60Hz 240V/50Hz	0,13 1,3	0,15 1,5	0,21 2,1	0,25 2,5	0,32 3,2	0,38 3,8	0,42 4,2	0,53 5,3	0,63 6,3	0,76 7,6	0,76 7,6	0,95 9,5	1,14 11,4	1,36 13,6	1,52 15,2	1,71 17,1	2,05 20,5	2,56 25,6	3 30	3 30	3 30	3 30	3 30	3 30	3 30
	90	200V/230V 50Hz/60Hz	0,09 0,9	0,11 1,1	0,15 1,5	0,18 1,8	0,23 2,3	0,28 2,8	0,31 3,1	0,38 3,8	0,46 4,6	0,55 5,5	0,55 5,5	0,69 6,9	0,83 8,3	1,00 10,0	1,11 11,1	1,25 12,5	1,50 15,0	1,87 18,7	2,24 22,4	2,49 24,9	2,99 29,9	3 30	3 30	3 30	3 30
		220V/50Hz/60Hz 240V/50Hz	0,07 0,7	0,09 0,9	0,12 1,2	0,15 1,5	0,18 1,8	0,22 2,2	0,24 2,4	0,30 3,0	0,36 3,6	0,44 4,4	0,44 4,4	0,55 5,5	0,66 6,6	0,79 7,9	0,87 8,7	0,98 9,8	1,18 11,8	1,48 14,8	1,77 17,7	1,97 19,7	2,36 23,6	2,95 29,5	3 30	3 30	3 30

- * Gearhead and decimal gearhead are sold separately.
- * The code in □ of gearhead model is for gear ratio.
- * color indicates that the output shaft of the geared motor rotates in the same direction as the output shaft of the motor. Others indicate rotation in the opposite direction.
- * If you are to have less ratio than the ratio in the table, you can install the decimal gearhead, which has one tenth of the ratio, between the gearhead and the motor. In this case, the permissible torque is 3N · m/30kgfcm.
- * RPM is based on motor's synchronous rpm (50Hz:1500rpm, 60Hz:1800rpm) and calculated by dividing gear ratio. Actual rpm is 2~20% less than indicating rpm according to load size.

GEARHEADS

CONNECTION DIAGRAMS

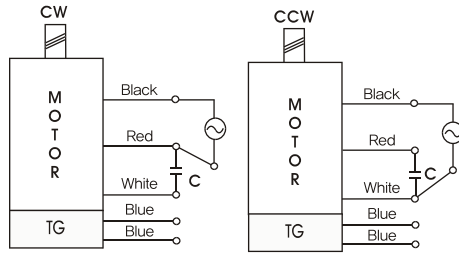

※The direction of motor rotation is as viewed from the front shaft end of the motor

DIMENSIONS

K6G□B(C)



K6RG6N□-SP + K6G□B(C)



DECIMAL GEARHEAD

K6G10BX

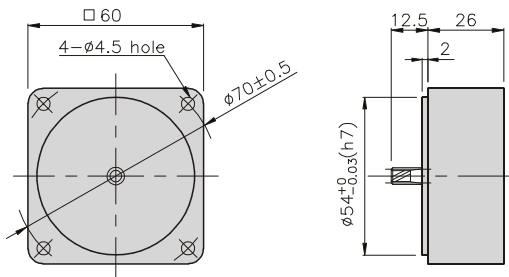

GEARHEAD

K6G□B(C)

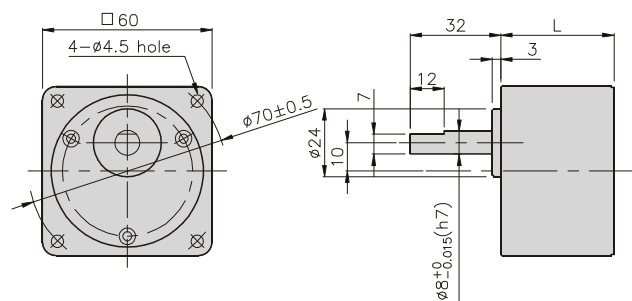

DIMENSION TABLE

PART No.	L	Application Model	Mounting BOLT
01	30	K6G3~18B(C)	M4 P0,7 X 50
02	40	K6G20~250B(C)	M4 P0,7 X 60
03	26	K6G10BX	M4 P0,7 X 85

WEIGHT

PART	WEIGHT(kg)	
MOTOR	0.79	
DECIMAL GEAR HEAD	0.22	
GEAR HEAD	K6G3~18B(C)	0.26
	K6G20~40B(C)	0.33
	K6G60~250B(C)	0.36

K6RG6N□-SP + K6G□B(C)

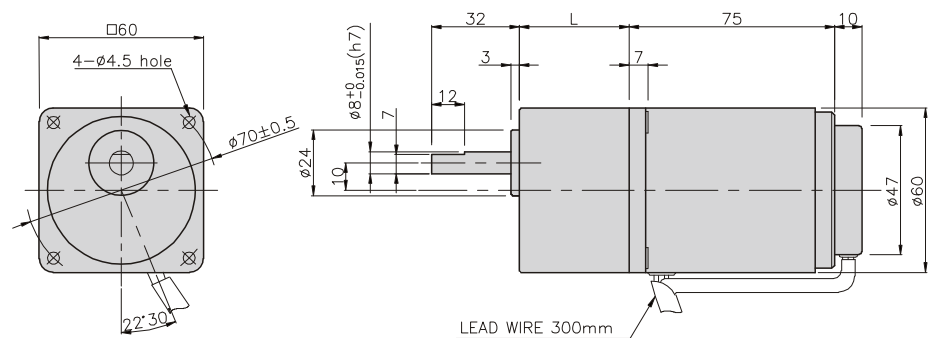

SPEED CONTROL MOTOR - SU SERIES

6W

□60mm

K6□S6N□-SU

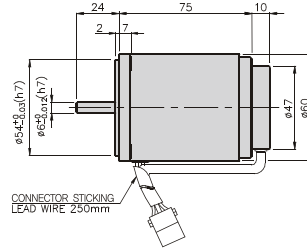
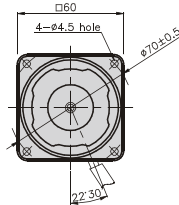

SPECIFICATIONS

6W continuous rating, four poles

Model	Voltage (V)	Frequency (Hz)	Speed Range (rpm)	Permissible Torque		Start T. (N*m/Kgf*cm)	Current (A)	Condenser (μF)
				1200rpm (N*m/Kgf*cm)	90rpm (N*m/Kgf*cm)			
K6I□6NJ-SU	100	50	90 ~ 1400	0,05/0,5	0,03/0,3	0,029/0,29	0,28	3
		60	90 ~ 1700					
K6I□6NU-SU	110	60	90 ~ 1700	0,05/0,5	0,03/0,3	0,03/0,3	0,24	2
	115							
K6I□6NL-SU	200	50	90 ~ 1400	0,05/0,5	0,029/0,29	0,03/0,3	0,19	0,8
		60	90 ~ 1700					
K6I□6NC-SU	220	50	90 ~ 1400	0,05/0,5	0,029/0,29	0,029/0,29	0,2	0,6
		60	90 ~ 1700					
	230	50	90 ~ 1400					
		60	90 ~ 1700					
K6I□6ND-SU	240	50	90 ~ 1400	0,05/0,5	0,029/0,29	0,03/0,3	0,21	0,5

* □ : SHAFT SHAPE (S : STRAIGHT, G : PINION)

RATED TORQUE OF GEARHEAD

● Single-phase 100V/115V

unit = above : N · m / below : kgfcm

Model Motor/Gearhead	Ratio Speed(rpm)	3	3,6	5	6	7,5	9	10	12,5	15	18	20	25	30	36	40	50	60	75	90	100	120	150	180	200	250
		K6I□6N□-SU K6G□B(C)	1200	0,12 1,2	0,15 1,5	0,20 2,0	0,24 2,4	0,30 3,0	0,36 3,6	0,41 4,1	0,51 5,1	0,61 6,1	0,73 7,3	0,73 7,3	0,91 9,1	1,09 10,9	1,31 13,1	1,46 14,6	1,64 16,4	1,97 19,7	2,46 24,6	2,95 29,5	3 30	3 30	3 30	3 30
	90	0,07 0,7	0,08 0,8	0,12 1,2	0,14 1,4	0,18 1,8	0,21 2,1	0,23 2,3	0,26 2,6	0,32 3,2	0,42 4,2	0,42 4,2	0,53 5,3	0,63 6,3	0,76 7,6	0,85 8,5	0,95 9,5	1,14 11,4	1,43 14,3	1,71 17,1	1,90 19,0	2,28 22,8	2,85 28,5	3 30	3 30	3 30

● Single-phase 200V/240V

unit = above : N · m / below : kgfcm

Model Motor/Gearhead	Ratio Speed(rpm)	3	3,6	5	6	7,5	9	10	12,5	15	18	20	25	30	36	40	50	60	75	90	100	120	150	180	200	250
		K6I□6N□-SU K6G□B(C)	1200	0,12 1,2	0,15 1,5	0,20 2,0	0,24 2,4	0,30 3,0	0,36 3,6	0,41 4,1	0,51 5,1	0,61 6,1	0,73 7,3	0,73 7,3	0,91 9,1	1,09 10,9	1,31 13,1	1,46 14,6	1,64 16,4	1,97 19,7	2,46 24,6	2,95 29,5	3 30	3 30	3 30	3 30
	90	0,07 0,7	0,08 0,8	0,12 1,2	0,14 1,4	0,18 1,8	0,21 2,1	0,23 2,3	0,29 2,9	0,35 3,5	0,42 4,2	0,42 4,2	0,53 5,3	0,63 6,3	0,76 7,6	0,85 8,5	0,95 9,5	1,14 11,4	1,43 14,3	1,71 17,1	1,90 19,0	2,28 22,8	2,85 28,5	3 30	3 30	3 30

- * Gearhead and decimal gearhead are sold separately.
- * The code in □ of gearhead model is for gear ratio.
- * ■ color indicates that the output shaft of the geared motor rotates in the same direction as the output shaft of the motor. Others indicate rotation in the opposite direction.
- * If you are to have less ratio than the ratio in the table, you can install the decimal gearhead, which has one tenth of the ratio, between the gearhead and the motor. In this case, the permissible torque is 3N · m/30kgfcm.
- * RPM is based on motor's synchronous rpm (50HZ:1500rpm, 60HZ:1800rpm) and calculated by dividing gear ratio. Actual rpm is 2~20% less than indicating rpm according to load size.

GEARHEADS

CONNECTION DIAGRAMS

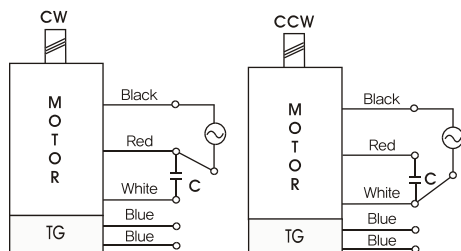

※The direction of motor rotation is as viewed from the front shaft end of the motor

DIMENSIONS

K6G□B(C)



K6IG6N□-SU + K6G□B(C)



DECIMAL GEARHEAD

K6G10BX

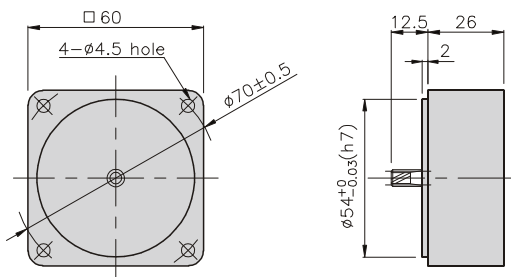

GEARHEAD

K6G□B(C)

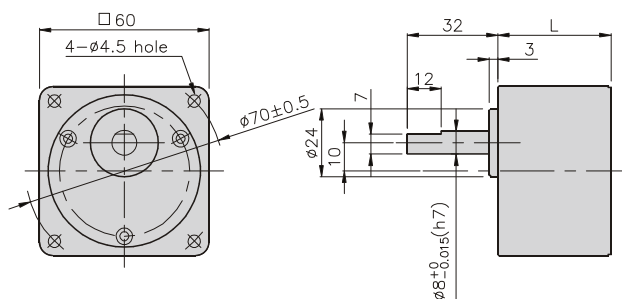

DIMENSION TABLE

PART No.	L	Application Model	Mounting BOLT
01	32	K6G3~18B(C)	M4 P0,7 X 50
02	40	K6G20~250B(C)	M4 P0,7 X 60
03	32	K6G10BX	M4 P0,7 X 85

WEIGHT

PART	WEIGHT(kg)	
MOTOR	0,79	
DECIMAL GEAR HEAD	0,22	
GEAR HEAD	K6G3~18B(C)	0,26
	K6G20~40B(C)	0,33
	K6G50~250B(C)	0,36

K6IG6N□-SU + K6G□B(C)

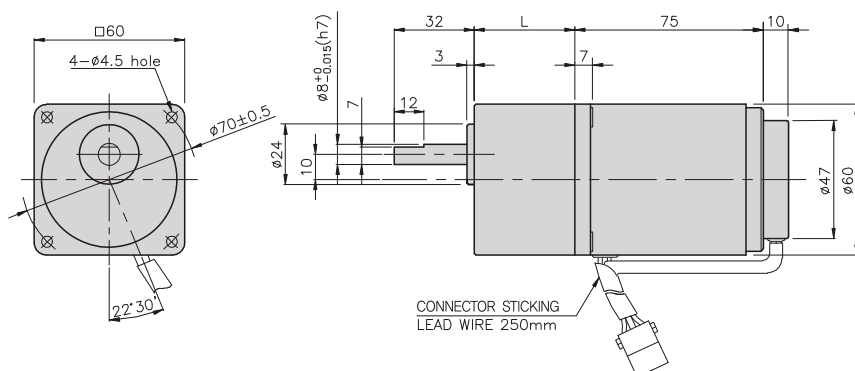

INDUCTION MOTOR

6W

□ 60mm

LEAD WIRE TYPE TERMINAL BOX TYPE

K6IS6N□



K6IS6N□-T



SPECIFICATIONS

6W continuous rating, four poles

Model	Voltage (V)	Frequency (Hz)	Current (A)	Start T. (N·m/Kgf·Cm)	Rated T. (N·m/Kgf·Cm)	Speed (rpm)	Condenser (μF)
single-phase							
K6I□6NJ(-T)	100	50	0,25	0,04/0,4	0,049/0,49	1200	3
		60	0,23			1500	
K6I□6NU(-T)	110	60	0,18	0,035/0,35	0,04/0,4	1500	2
	115		0,19	0,04/0,4			
K6I□6NL(-T)	200	50	0,11	0,045/0,45	0,049/0,49	1200	0,8
		60				0,04/0,4	
K6I□6NC(-T)	220	50	0,11	0,04/0,4	0,047/0,47	1250	0,6
		60	0,1	0,035/0,35	0,04/0,4	1500	
	230	50	0,12	0,045/0,45	0,047/0,47	1250	
		60	0,11	0,04/0,4	0,04/0,4	1500	
K6I□6ND(-T)	240	50	0,12	0,045/0,45	0,047/0,47	1250	0,5

* □ : SHAFT SHAPE (S : STRAIGHT, G : PINION)

RATED TORQUE OF GEARHEAD

● 50Hz

unit = above : N·m / below : kgfcm

Model Motor/ Gearhead	Speed(rpm)	500	416	300	250	200	166	150	120	100	83	75	60	50	41	37	30	25	20	16	15	12,5	10	8,3	7,5	6
	Ratio	3	3,6	5	6	7,5	9	10	12,5	15	18	20	25	30	36	40	50	60	75	90	100	120	150	180	200	250
K6I□6N□(-T) K6G□B(C)	0,11	0,14	0,19	0,23	0,29	0,34	0,38	0,48	0,57	0,69	0,69	0,86	1,03	1,23	1,37	1,54	1,85	2,31	2,78	3	3	3	3	3	3	3
	1,1	1,4	1,9	2,3	2,9	3,4	3,8	4,8	5,7	6,9	6,9	8,6	10,3	12,3	13,7	15,4	18,5	23,1	27,8	30	30	30	30	30	30	30

● 60Hz

unit = above : N·m / below : kgfcm

Model Motor/ Gearhead	Speed(rpm)	600	500	360	300	240	200	180	144	120	100	90	72	60	50	45	36	30	24	20	18	15	12	10	9	7,2
	Ratio	3	3,6	5	6	7,5	9	10	12,5	15	18	20	25	30	36	40	50	60	75	90	100	120	150	180	200	250
K6I□6N□(-T) K6G□B(C)	0,10	0,12	0,16	1,19	0,24	0,29	0,32	0,41	0,49	0,58	0,58	0,73	0,87	1,05	1,17	1,31	1,57	1,97	2,36	2,62	3	3	3	3	3	3
	1,0	1,2	1,6	1,9	2,4	2,9	3,2	4,1	4,9	5,8	5,8	7,3	8,7	10,5	11,7	13,1	15,7	19,7	23,6	26,2	30	30	30	30	30	30

* Gearhead and decimal gearhead are sold separately.

* The code in □ of gearhead model is for gear ratio.

* color indicates that the output shaft of the geared motor rotates in the same direction as the output shaft of the motor. Others indicate rotation in the opposite direction.

* If you are to have less ratio than the ratio in the table, you can install the decimal gearhead, which has one tenth of the ratio, between the gearhead and the motor. In this case, the permissible torque is 3N·m/30kgfcm.

* RPM is based on motor's synchronous rpm (50HZ:1500rpm, 60HZ:1800rpm) and calculated by dividing gear ratio. Actual rpm is 2~20% less than indicating rpm according to load size.

GEARHEADS

DIMENSIONS

K6IS6N □

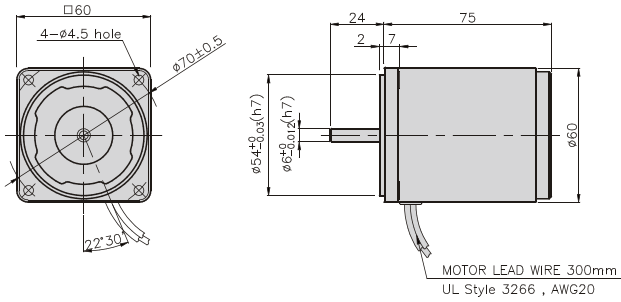

K6IS6N □-T

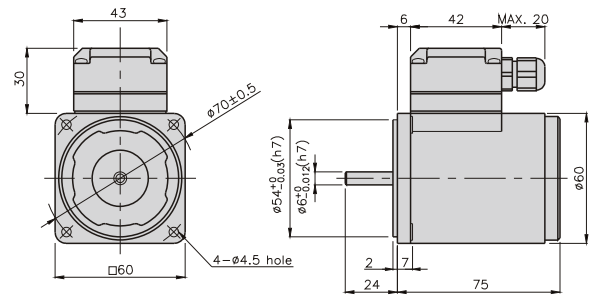

CONNECTION DIAGRAMS

K6IS6N □

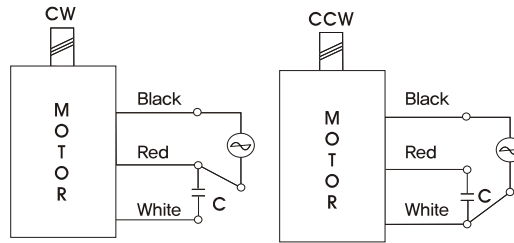

The direction of motor rotation is as viewed from the front shaft end of the motor

K6IS6N □-T

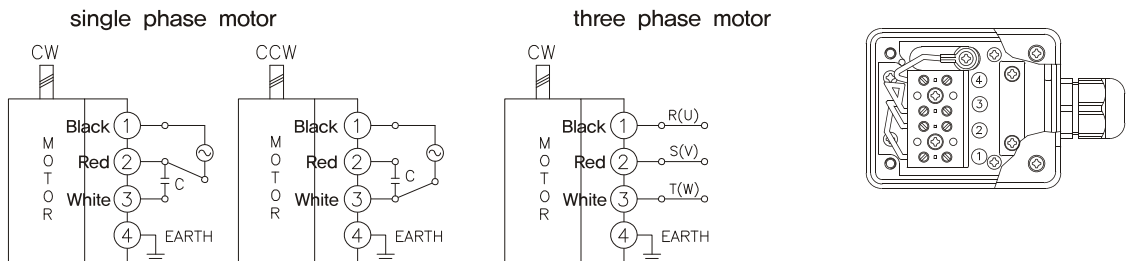

The direction of motor rotation is as viewed from the front shaft end of the motor

DIMENSIONS

K6G □(C)



DECIMAL GEARHEAD

K6G10BX □

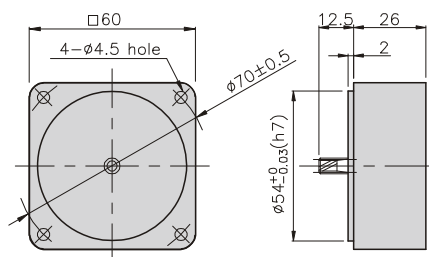

GEARHEAD

K6G □(C)

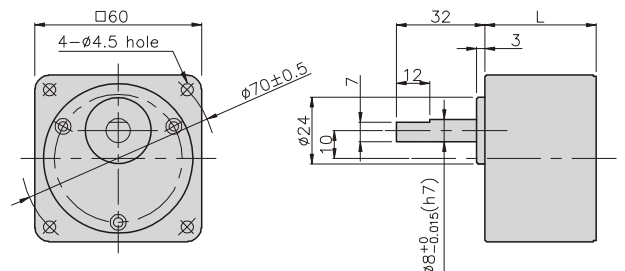

GEARHEADS

DIMENSIONS

K6IG6N□ + K6G□B(C)



K6IG6N□-T + K6G□B(C)



K6IG6N□ + K6G□B(C)

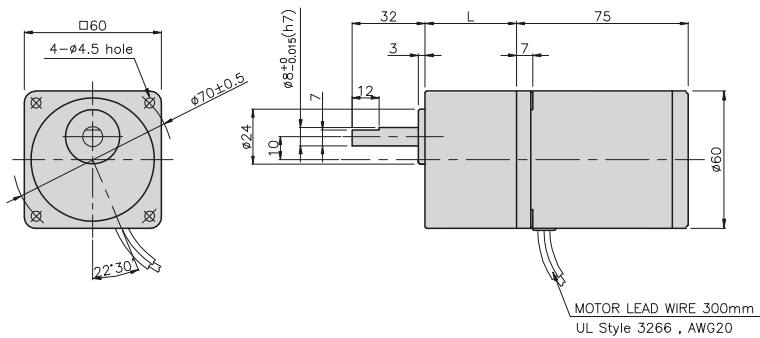

DIMENSION TABLE

PART No	L	Application Model	Mounting BOLT
01	30	K6G3~18B(C)	M4 P0,7 X 50
02	40	K6G20~250B(C)	M4 P0,7 X 60
03	26	K6G10BX	M4 P0,7 X 85

WEIGHT

PART	WEIGHT(kg)	
MOTOR	0,72	
DECIMAL GEAR HEAD	0,22	
GEAR HEAD	K6G3~18B(C)	0,26
	K6G20~40B(C)	0,33
	K6G50~250B(C)	0,36

K6IG6N□-T + K6G□B(C)

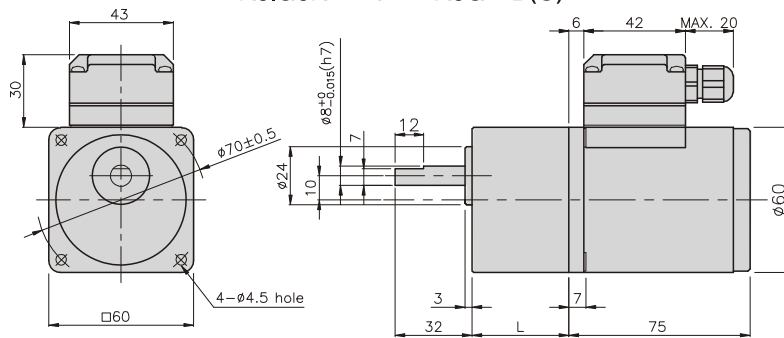

DIMENSION TABLE

PART No	L	Application Model	Mounting BOLT
01	30	K6G3~18B(C)	M4 P0,7 X 50
02	40	K6G20~250B(C)	M4 P0,7 X 60
03	26	K6G10BX	M4 P0,7 X 85

WEIGHT

PART	WEIGHT(kg)	
MOTOR	0,76	
DECIMAL GEAR HEAD	0,22	
GEAR HEAD	K6G3~18B(C)	0,26
	K6G20~40B(C)	0,33
	K6G50~250B(C)	0,36

REVERSIBLE MOTOR

6W

□ 60mm

LEAD WIRE TYPE TERMINAL BOX TYPE

K6RS6N□



K6RS6N□-T



SPECIFICATIONS

6W continuous rating, four poles

Model	Voltage (V)	Frequency (Hz)	Current (A)	Start T. (N*m/Kgf* Cm)	Rated T. (N*m/Kgf* Cm)	Speed (rpm)	Condenser (μF)
K6R□6NJ(-T)	100	50	0,25	0,035/0,35	0,049/0,49	1200	3
		60	0,23			1500	
K6R□6NU(-T)	110	60	0,2	0,045/0,45	0,04/0,4	1500	2,5
	115		0,2				
K6R□6NL(-T)	200	50	0,12	0,055/0,55	0,049/0,49	1200	1
		60	0,13			1500	
K6R□6NC(-T)	220	50	0,12	0,045/0,45	0,047/0,47	1250	0,8
		60	0,12			1500	
	230	50	0,15	0,055/0,55	0,047/0,47	1250	
		60	0,13			0,06/0,6	
K6R□6ND(-T)	240	50	0,12	0,048/0,48	0,047/0,47	1250	0,6

RATED TORQUE OF GEARHEAD

● 50Hz

unit = above : N · m / below : kgfcm

Model	Speed(rpm)	500	416	300	250	200	166	150	120	100	83	75	60	50	41	37	30	25	20	16	15	12,5	10	8,3	7,5	6	
Motor/ Gearhead	Ratio	3	3,6	5	6	7,5	9	10	12,5	15	18	20	25	30	36	40	50	60	75	90	100	120	150	180	200	250	
K6R□6N□(-T)		0,11	0,14	0,19	0,23	0,29	0,34	0,38	0,48	0,57	0,69	0,69	0,86	1,03	1,23	1,37	1,54	1,85	2,31	2,78	3	3	3	3	3	3	3
K6G□B(C)		1,1	1,4	1,9	2,3	2,9	3,4	3,8	4,8	5,7	6,9	6,9	8,6	10,3	12,3	13,7	15,4	18,5	21,3	27,8	30	30	30	30	30	30	30

● 60Hz

unit = above : N · m / below : kgfcm

Model	Speed(rpm)	600	500	360	300	240	200	180	144	120	100	90	72	60	50	45	36	30	24	20	18	15	12	10	9	7,2	
Motor/ Gearhead	Ratio	3	3,6	5	6	7,5	9	10	12,5	15	18	20	25	30	36	40	50	60	75	90	100	120	150	180	200	250	
K6R□6N□(-T)		0,10	0,12	0,16	0,19	0,24	0,29	0,32	0,41	0,49	0,58	0,58	0,73	0,87	1,05	1,17	1,31	1,57	1,97	2,36	2,62	3	3	3	3	3	3
K6G□B(C)		1,0	1,2	1,6	1,9	2,4	2,9	3,2	4,1	4,9	5,8	5,8	7,3	8,7	10,5	11,7	13,1	15,7	19,7	23,6	26,2	30	30	30	30	30	30

- * Gearhead and decimal gearhead are sold separately.
- * The code in □ of gearhead model is for gear ratio.
- * color indicates that the output shaft of the geared motor rotates in the same direction as the output shaft of the motor. Others indicate rotation in the opposite direction.
- * If you are to have less ratio than the ratio in the table, you can install the decimal gearhead, which has one tenth of the ratio, between the gearhead and the motor. In this case, the permissible torque is 3N · m/30kgfcm.
- * RPM is based on motor's synchronous rpm (50HZ:1500rpm, 60HZ:1800rpm) and calculated by dividing gear ratio. Actual rpm is 2~20% less than indicating rpm according to load size.

GEARHEADS

DIMENSIONS

K6RS6N □

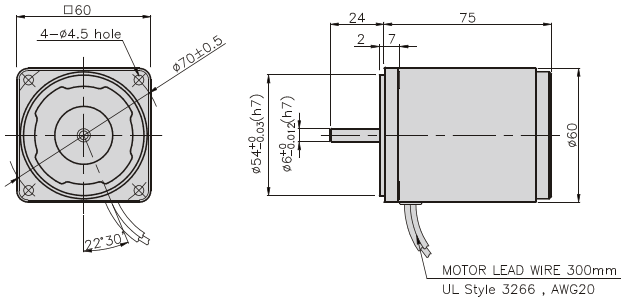

K6RS6N □-T

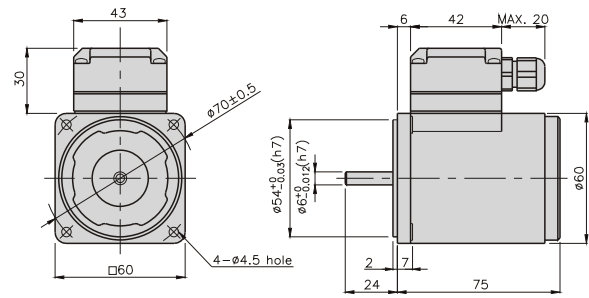

CONNECTION DIAGRAMS

K6RS6N □

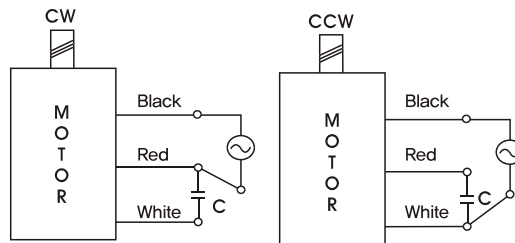

The direction of motor rotation is as viewed from the front shaft end of the motor

K6RS6N □-T

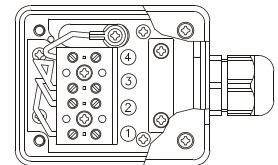
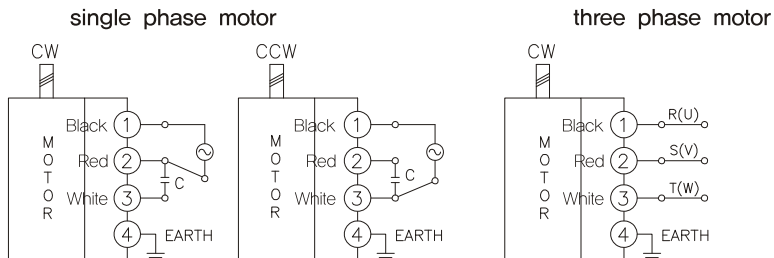

The direction of motor rotation is as viewed from the front shaft end of the motor

DIMENSIONS

K6G □(C)



DECIMAL GEARHEAD

K6G10BX □

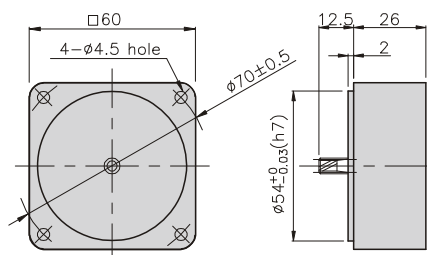

GEARHEAD

K6G □(C)

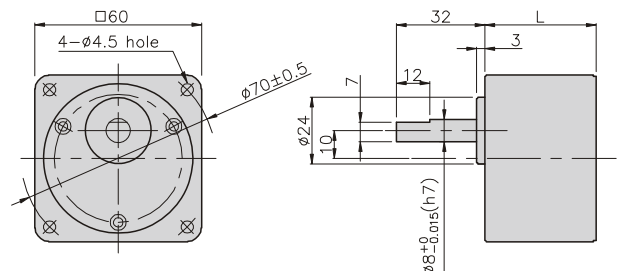

GEARHEADS

DIMENSIONS

K6RG6N□ + K6G□B(C)



K6RG6N□-T + K6G□B(C)



K6RG6N□ + K6G□B(C)

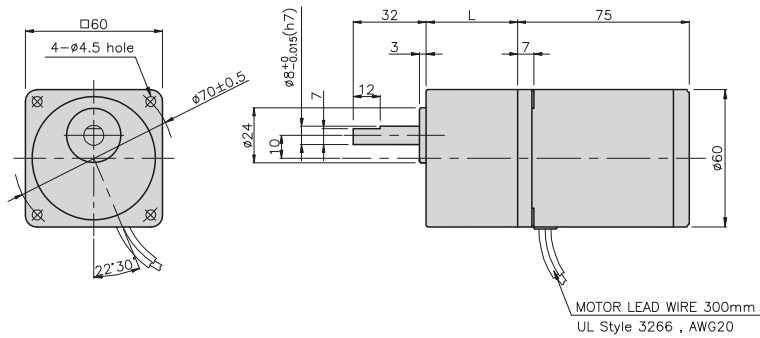

DIMENSION TABLE

PART No	L	Application Model	Mounting BOLT
01	30	K6G3~18B(C)	M4 P0,7 X 50
02	40	K6G20~250B(C)	M4 P0,7 X 60
03	26	K6G10BX	M4 P0,7 X 85

WEIGHT

PART	WEIGHT(kg)	
MOTOR	0,72	
DECIMAL GEAR HEAD	0,22	
GEAR HEAD	K6G3~18B(C)	0,26
	K6G20~40B(C)	0,33
	K6G50~250B(C)	0,36

K6RG6N□-T + K6G□B(C)

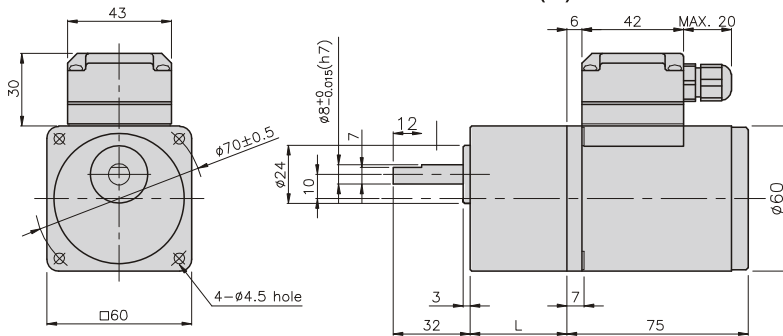

DIMENSION TABLE

PART No	L	Application Model	Mounting BOLT
01	30	K6G3~18B(C)	M4 P0,7 X 50
02	40	K6G20~250B(C)	M4 P0,7 X 60
03	26	K6G10BX	M4 P0,7 X 85

WEIGHT

PART	WEIGHT(kg)	
MOTOR	0,76	
DECIMAL GEAR HEAD	0,22	
GEAR HEAD	K6G3~18B(C)	0,26
	K6G20~40B(C)	0,33
	K6G50~250B(C)	0,36

DC MOTORS

6W
~15W

□ 60mm

DIMENSIONS

K6DS□N□

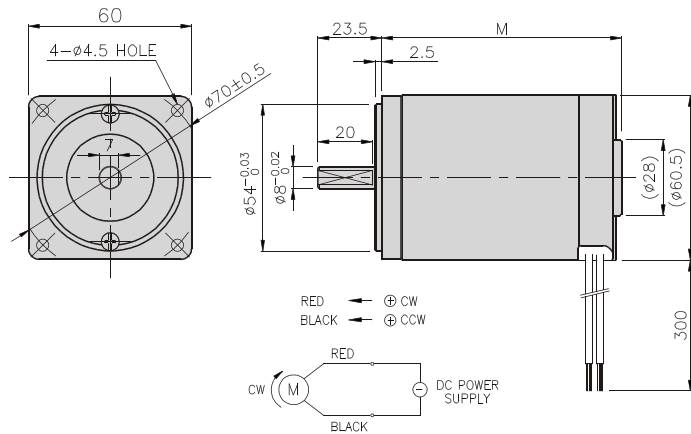

CONNECTION DIAGRAMS

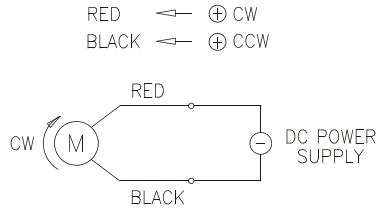

DIMENSION TABLE

M	MOTOR
73	K6D□ 6N□
88	K6D□ 15N□

SPECIFICATIONS

Model	Output (W)	Voltage (V)	RATED			Starting Torque (kgf*cm)	Starting Current (A)
			Speed (rpm)	Torque (kgf*cm)	Current (A)		
K6D□6N1	6	12	3000	0,195	1,3	2,2	8,3
K6D□6N2		24	3000		0,7	2,4	4,3
K6D□6N3		90	3000		0,07	2,8	1,2
K6D□15N1	15	12	3000	0,490	1,7	3,7	13,5
K6D□15N2		24	3000		1,2	4,1	7,7
K6D□15N3		90	2900	0,505	0,16	4,5	1,9

* □ : SHAFT SHAPE (S : STRAIGHT, G : PINION)

GEARHEAD

DIMENSIONS

DECIMAL GEARHEAD

K6G10BX

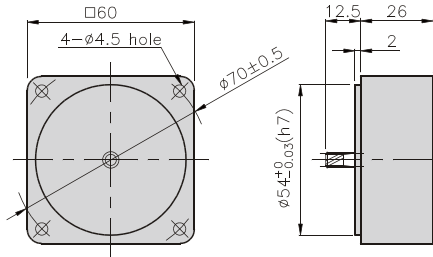

GEAR HEAD

K6G□B(C)

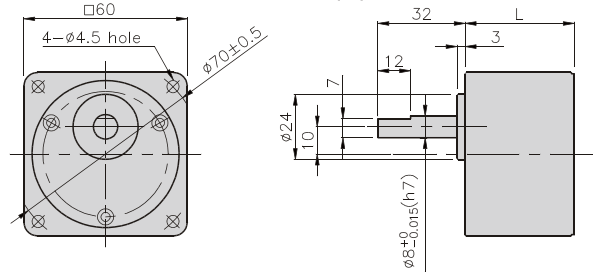

DIMENSION TABLE

L	GEAR HEAD	M	MOTOR
30	K6G3~ 20B(C)	73	K6D□ 6N□
40	K6G25~ 250B(C)	88	K6D□ 15N□

K6DG□N□ + K6G□B(C)

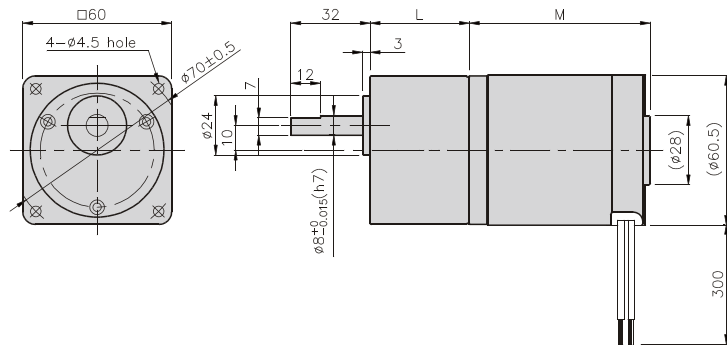

DC MOTORS

RATED TORQUE OF GEARHEAD

● DC12V, DC24V, DC90V 6W

unit = above : N · m / below : kgfcm

Model Motor/ Gear head	Speed (rpm)	1000	833	600	500	400	333	300	240	200	167	150	120	100	83	75	60	50	40	33	30	25	20	17	15	12
	Ratio	3	3,6	5	6	7,5	9	10	12,5	15	18	20	25	30	36	40	50	60	75	90	100	120	150	180	200	250
K6DG6N□ K6G□B(C)		0,05 0,5	0,06 0,6	0,08 0,8	0,09 0,9	0,12 1,2	0,14 1,4	0,16 1,6	0,20 2,0	0,24 2,4	0,28 2,8	0,28 2,8	0,36 3,6	0,43 4,3	0,51 5,1	0,57 5,7	0,64 6,4	0,77 7,7	0,96 9,6	1,15 11,5	1,28 12,8	1,54 15,4	1,92 19,2	2,30 23,0	2,56 25,6	3 30

● DC12V, DC24V 15W

unit = above : N · m / below : kgfcm

Model MOTOR/ GEAR HEAD	Speed (rpm)	1000	833	600	500	400	333	300	240	200	167	150	120	100	83	75	60	50	40	33	30	25	20	17	15	12
	Ratio	3	3,6	5	6	7,5	9	10	12,5	15	18	20	25	30	36	40	50	60	75	90	100	120	150	180	200	250
K6DG15N(2) K6G□B(C)		0,12 1,2	0,14 1,4	0,20 2,0	0,24 2,4	0,30 3,0	0,36 3,6	0,40 4,0	0,50 5,0	0,60 6,0	0,71 7,1	0,71 7,1	0,89 8,9	1,07 10,7	1,29 12,9	1,43 14,3	1,61 16,1	1,93 19,3	2,41 24,1	2,89 28,9	3 30	3 30	3 30	3 30	3 30	3 30

● DC90V 15W

unit = above : N · m / below : kgfcm

Model MOTOR/ GEAR HEAD	Speed (rpm)	967	806	580	483	387	322	290	232	193	161	145	116	97	81	73	58	48	39	32	29	24	19	16	14,5	11,6
	Ratio	3	3,6	5	6	7,5	9	10	12,5	15	18	20	25	30	36	40	50	60	75	90	100	120	150	180	200	250
K6DG15N3 K6G□B(C)		0,12 1,2	0,15 1,5	0,20 2,0	0,25 2,5	0,31 3,1	0,37 3,7	0,41 4,1	0,51 5,1	0,61 6,1	0,74 7,4	0,74 7,4	0,92 9,2	1,10 11,0	1,33 13,3	1,47 14,7	1,66 16,6	1,99 19,9	2,48 24,8	2,98 29,8	3 30	3 30	3 30	3 30	3 30	3 30