

KGB-BRAKE TYPE

DIMENSIONS

KGB BRAKE SERIES

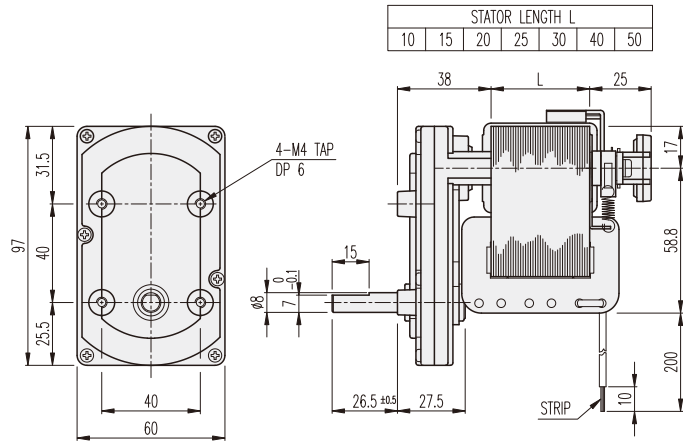

AT MAXIMUM EFFICIENCY (KGB-□□□-KA61□□BE)

GEAR RATIO	MOTOR		KA6120BE		KA6130BE				KA6140BE				KA6150BE					
			50		60		50		60		50		60		50		60	
	rpm	kgf-cm	rpm	kgf-cm	rpm	kgf-cm	rpm	kgf-cm	rpm	kgf-cm	rpm	kgf-cm	rpm	kgf-cm	rpm	kgf-cm	rpm	kgf-cm
1/010	240	1.2	290	1	240	2.7	290	2.5	240	4	290	3.7	240	6.4	290	5		
1/015	160	1.8	193.3	1.4	160	4.1	193.3	3.7	160	6	193.3	5.6	160	9.6	193.3	7.5		
1/021	114.3	2.5	138.1	2	114.3	5.8	138.1	5.2	114.3	8.4	138.1	7.9	114.3	13.5	138.1	10.5		
1/027	88.9	3.2	107.4	2.6	88.9	7.4	107.4	6.7	88.9	10.8	107.4	10.1	88.9	17.3	107.4	13.5		
1/036	66.7	4.3	80.6	3.5	66.7	9.9	80.6	8.9	66.7	14.4	80.6	13.5	66.7	20	80.6	18		
1/043	55.8	5.1	67.4	4.1	55.8	11.8	67.4	10.6	55.8	17.2	67.4	16.1	55.8	20	67.4	20		
1/047	51.1	5.6	61.7	4.5	51.1	12.9	61.7	11.6	51.1	20	61.7	17.6	51.1	20	61.7	20		
1/055	43.6	6.5	52.7	5.3	43.6	15.1	52.7	13.6	43.6	20	52.7	20	43.6	20	52.7	20		
1/060	40	7.1	48.3	5.8	40	16.4	48.3	14.8	40	20	48.3	20	40	20	48.3	20		
1/075	32	8.9	38.7	7.2	32	20	38.7	18.5	32	20	38.7	20	32	20	38.7	20		
1/086	27.9	10.2	33.7	8.3	27.9	20	33.7	20	27.9	20	33.7	20	27.9	20	33.7	20		
1/100	24	11.8	29	9.6	24	20	29	20	24	20	29	20	24	20	29	20		
1/115	20.9	13.6	25.2	11.1	20.9	20	25.2	20	20.9	20	25.2	20	20.9	20	25.2	20		
1/126	19	14.9	23	12.1	19	20	23	20	19	20	23	20	19	20	23	20		
1/131	18.3	15.5	22.1	12.6	18.3	20	22.1	20	18.3	20	22.1	20	18.3	20	22.1	20		
1/154	15.6	18.2	18.8	14.8	15.6	20	18.8	20	15.6	20	18.8	20	15.6	20	18.8	20		
1/172	14	20	16.9	16.6	14	20	16.9	20	14	20	16.9	20	14	20	16.9	20		
1/215	11.2	20	13.5	20	11.2	20	13.5	20	11.2	20	13.5	20	11.2	20	13.5	20		
1/300	8	20	9.7	20	8	20	9.7	20	8	20	9.7	20	8	20	9.7	20		
1/380	6.3	20	7.6	20	6.3	20	7.6	20	6.3	20	7.6	20	6.3	20	7.6	20		
1/408	5.9	20	7.1	20	5.9	20	7.1	20	5.9	20	7.1	20	5.9	20	7.1	20		
1/532	4.5	20	5.5	20	4.5	20	5.5	20	4.5	20	5.5	20	4.5	20	5.5	20		
1/673	3.6	20	4.3	20	3.6	20	4.3	20	3.6	20	4.3	20	3.6	20	4.3	20		
1/825	2.9	20	3.5	20	2.9	20	3.5	20	2.9	20	3.5	20	2.9	20	3.5	20		

* Above data is based on brake type of shaded pole motor appliad.
 * color gear ratios are same rotation direction with motor.
 * The standard is F-TYPE.