

## REVERSIBLE MOTOR

### 90W

### □90mm

LEAD WIRE TYPE  
TERMINAL BOX TYPE

K9RS90F□



K9RS90F□-T, T5



### SPECIFICATIONS

90W 30분 정격, 4극

Model	Voltage (V)	Frequency (Hz)	Current (A)	Start T. (N*m/ Kgf* Cm)	Rated T. (N*m/ Kgf* Cm)	Speed (rpm)	Condenser (μF)
K9R□90FJ(-T, -T5)	100	50	2,52	0,6/6	0,705/7,05	1250	35
		60	2,42		0,57/5,7	1550	
K9R□90FU(-T, -T5)	110	60	1,88	0,55/5,5	0,57/5,7	1550	25
	115		2,12				
K9R□90FL(-T, -T5)	220	50	0,9	0,55/5,5	0,705/7,05	1250	8
		60	1,1		0,57/5,7	1550	
K9R□90FC(-T, -T5)	220	50	1	0,5/5	0,705/7,05	1250	7
		60	1,1	0,53/5,3	0,57/5,7	1550	
	230	50	1,3	0,6/6	0,705/7,05	1250	
		60	1,1		0,57/5,7	1550	
K9R□90FD(-T, -T5)	240	50	0,94	0,55/5,5	0,705/7,05	1250	6

\* □ : SHAFT 형상(S : STRAIGHT, P : PINION)

### RATED TORQUE OF GEARHEAD

#### ● 50Hz

단위 = 상단 : N·m / 하단 : Kgfcm

Model	Speed(rpm)	500	416	300	250	200	166	150	120	100	83	75	60	50	41	37	30	25	20	16	15	12,5	10	8,3	7,5
Motor/ Gearhead	Ratio	3	3,6	5	6	7,5	9	10	12,5	15	18	20	25	30	36	40	50	60	75	90	100	120	150	180	200
K9R□90F□(-T, -T5) K9P□B, BF		1,71	2,06	2,86	3,43	4,28	5,14	5,71	6,42	7,71	9,25	10,28	11,56	13,88	16,65	18,5	20	20	20	20	20	20	20	20	20
		17,1	20,6	28,6	34,3	42,8	51,4	57,1	64,2	77,1	92,5	102,8	115,6	138,8	166,5	185,0	200	200	200	200	200	200	200	200	200

#### ● 60Hz

단위 = 상단 : N·m / 하단 : Kgfcm

Model	Speed(rpm)	600	500	360	300	240	200	180	144	120	100	90	72	60	50	45	36	30	24	20	18	15	12	10	9
Motor/ Gearhead	Ratio	3	3,6	5	6	7,5	9	10	12,5	15	18	20	25	30	36	40	50	60	75	90	100	120	150	180	200
K9R□90F□(-T, -T5) K9P□B, BF		1,39	1,66	2,31	2,77	3,46	4,16	4,62	5,19	6,23	7,48	8,31	9,35	11,22	13,46	14,96	18,7	20	20	20	20	20	20	20	20
		13,9	16,6	23,1	27,7	34,6	41,6	46,2	51,9	62,3	74,8	83,1	93,5	112,2	134,6	149,6	187	200	200	200	200	200	200	200	200

\* GEARHEAD · DECIMAL GEARHEAD는 별매입니다.

\* GEARHEAD의 품명중 □에는 감속비가 들어갑니다.

\* ■ 색이 MOTOR와 같은 방향, 그 외에는 반대 방향입니다.

\* 표의 감속비보다 더 감속하고자 할 경우는 GEARHEAD와 MOTOR 사이에 감속비 10의 DECIMAL GEARHEAD를 설치할 수 있습니다. 이 경우의 허용 TORQUE는 20N·m/200kgfcm 입니다.

\* 회전수는 MOTOR의 동기 회전수(50Hz:1500rpm, 60Hz:1800rpm)를 기준으로 하여 감속비로 나누어서 계산하였습니다. 실제의 회전수는 부하의 크기에 따라서 표시된 수치보다 2~20% 적습니다.

## GEARHEADS

### RATED TORQUE OF GEARHEAD

#### ● 50Hz

단위 = 상단 : N·m / 하단 : Kgcm

Model	Speed(rpm)	500	416	300	250	200	166	150	120	100	83	75	60	50	41	37	30	25	20	16	15	13	10	8,3	7,5
Motor/ Gearhead	Ratio	3	3,6	5	6	7,5	9	10	12,5	15	18	20	25	30	36	40	50	60	75	90	100	120	150	180	200
K9R□90F□(-T, -T5) K9RP□BU, BUF		1,71	2,06	2,86	3,43	4,28	5,14	5,71	6,42	7,71	9,25	10,28	11,56	13,88	16,65	18,50	23,13	27,75	30	30	30	30	30	30	30
		17,1	20,6	28,6	34,3	42,8	51,4	57,1	64,2	77,1	92,5	102,8	115,6	138,8	165,6	185,0	231,3	277,5	300	300	300	300	300	300	300

#### ● 60Hz

단위 = 상단 : N·m / 하단 : Kgcm

Model	Speed(rpm)	600	500	360	300	240	200	180	144	120	100	90	72	60	50	45	36	30	24	20	18	15	12	10	9
Motor/ Gearhead	Ratio	3	3,6	5	6	7,5	9	10	12,5	15	18	20	25	30	36	40	50	60	75	90	100	120	150	180	200
K9R□90F□(-T, -T5) K9RP□BU, BUF		1,39	1,66	2,31	2,77	3,46	4,16	4,62	5,19	6,23	7,48	8,31	9,35	11,22	13,46	14,96	18,70	22,44	25,24	30	30	30	30	30	30
		13,9	16,6	23,1	27,7	34,6	41,6	46,2	51,9	62,3	74,8	83,1	93,5	112,2	134,6	149,6	187,0	224,4	252,4	300	300	300	300	300	300

- \* GEARHEAD · DECIMAL GEARHEAD는 별매입니다.
- \* GEARHEAD의 품명중 □에는 감속비가 들어갑니다.
- \* ■ 색이 MOTOR와 같은 방향, 그 외에는 반대 방향입니다.
- \* 표의 감속비보다 더 감속하고자 할 경우는 GEARHEAD와 MOTOR 사이에 감속비 10의 DECIMAL GEARHEAD를 설치할 수 있습니다.
- \* 이 경우의 허용 TORQUE는 30N·m/300kgcm 입니다.
- \* 회전수는 MOTOR의 동기 회전수(50Hz:1500rpm, 60Hz:1800rpm)를 기준으로 하여 감속비로 나누어서 계산하였습니다. 실제의 회전수는 부하의 크기에 따라서 표시된 수치보다 2~20% 적습니다.

### DIMENSIONS

K9RS90F□

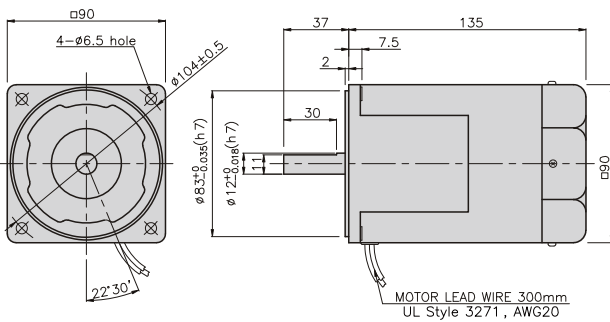

K9RS90F□-T

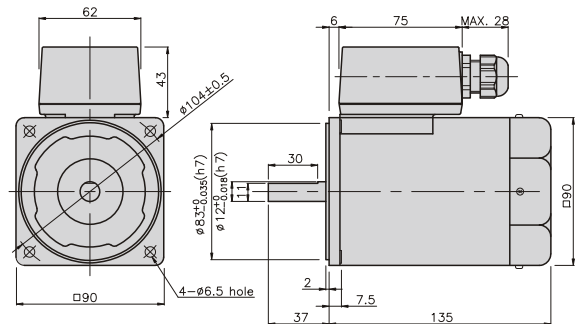

K9RS90F□-T5

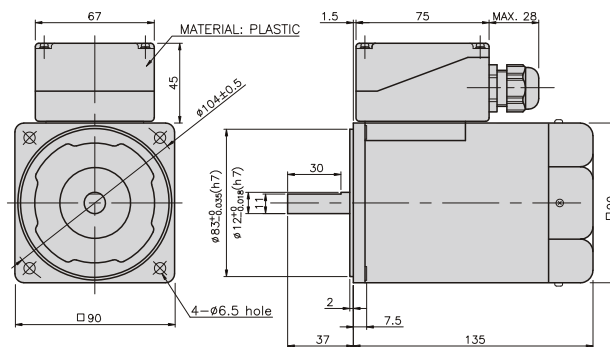

## GEARHEADS

### CONNECTION DIAGRAMS

K9RS90F□

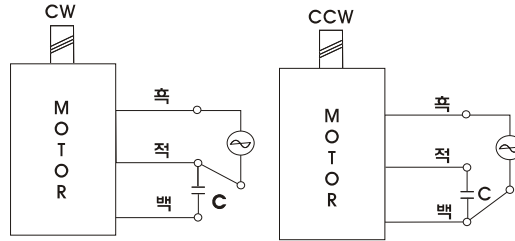

회전방향은 출력축에서 볼 경우

K9RS90F□-T

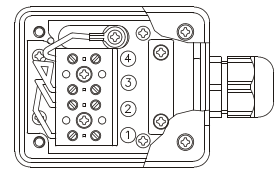
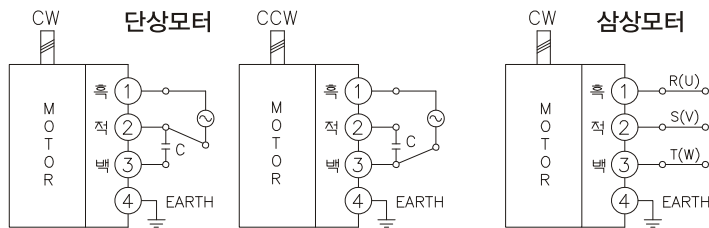

회전방향은 출력축에서 볼 경우

K9RS90F□-T5

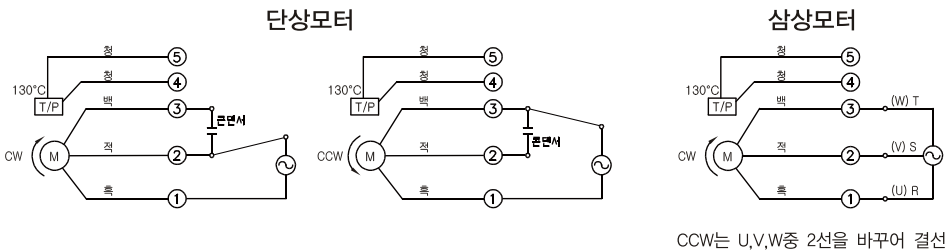

CCW는 U,V,W중 2선을 바꾸어 결선

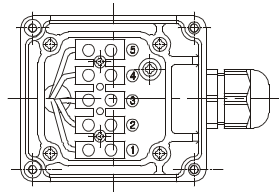

회전방향은 출력축에서 볼 경우

## GEARHEADS

### DIMENSIONS

K9P□B



K9P□BF, BUF



K9P□BU



DECIMAL GEARHEAD

K9P10BX

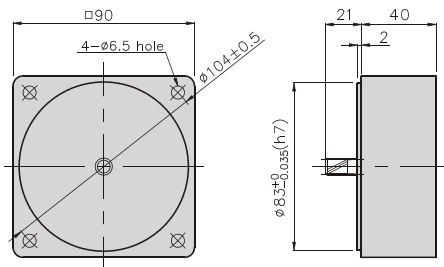

GEAR HEAD

K9P□B

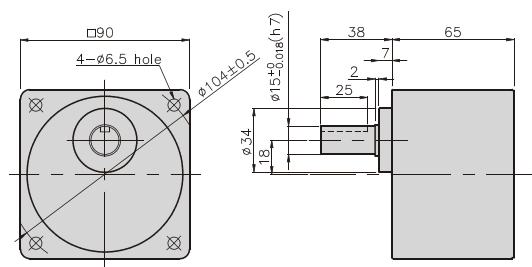

GEARHEAD

K9P□BF

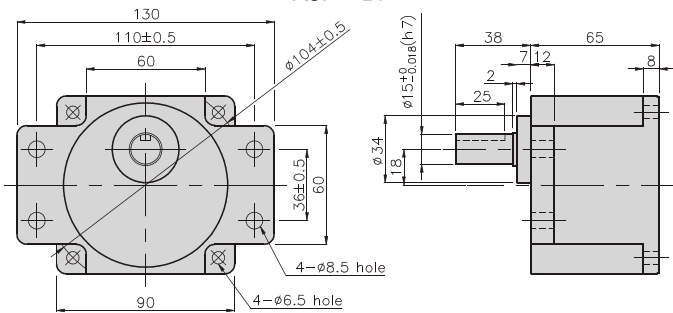

GEARHEAD

K9P□BU

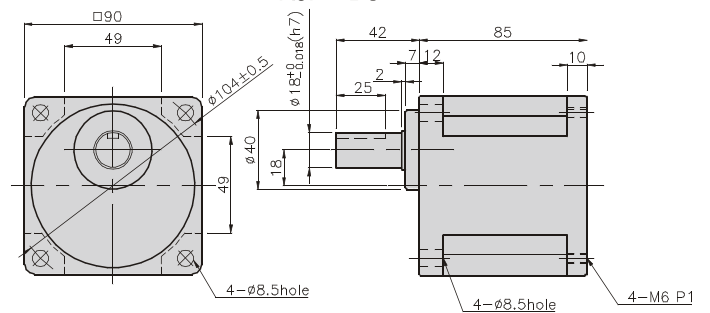

GEARHEAD

K9P□BUF

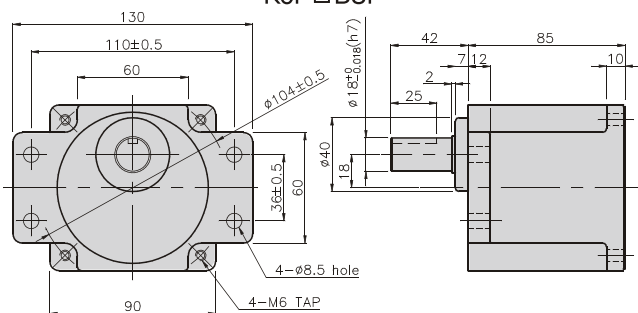

● KEY

● KEY GROOVE

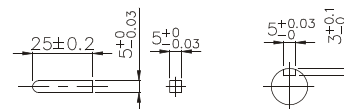

## GEARHEADS

### DIMENSIONS

K9RP90F□ + K9P□B



K9RP90F□ + K9P□BF, BUF



K9RP90F□ + K9P□BU



#### 무게

PART	WEIGHT(kg)
MOTOR	3,05
DECIMAL GEAR HEAD	0,62

#### 치수도표

품번	L	적용기종	취부 BOLT
01	65	K9P3~200B	M6 P1,0 X 95
02	40	K9P10BX	M6 P1,0 X 140

#### 무게

PART	WEIGHT(kg)
K9P3~10B	1,22
K9P12,5~20B	1,32
K9P25~60B	1,42
K9P75~200B	1,45

#### 치수도표

품번	L	적용기종	취부 BOLT
01	65	K9P3~200BF	M6 P1,0 X 25
02	40	K9P10BX	M6 P1,0 X 65

#### 무게

PART	WEIGHT(kg)
K9P3~10BF	1,22
K9P12,5~20BF	1,30
K9P25~60BF	1,42
K9P75~200BF	1,44

#### 치수도표

품번	L	적용기종	취부 BOLT
01	85	K9P3~200BU	M6 P1,0 X 20
02	40	K9P10BX	M6 P1,0 X 60

#### 무게

PART	WEIGHT(kg)
K9P3~10BU	1,44
K9P12,5~20BU	1,55
K9P25~60BU	1,69
K9P75~200BU	1,74

#### 치수도표

품번	L	적용기종	취부 BOLT
01	85	K9P3~200BUF	M6 P1,0 X 20
02	40	K9P10BX	M6 P1,0 X 65

#### 무게

PART	WEIGHT(kg)
K9P3~10BUF	1,50
K9P12,5~20BUF	1,62
K9P25~60BUF	1,76
K9P75~200BUF	1,82

K9RP90F□ + K9P□B

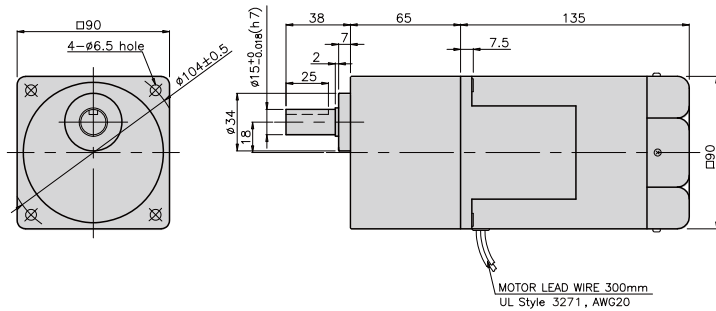

K9RP90F□ + K9P□BF

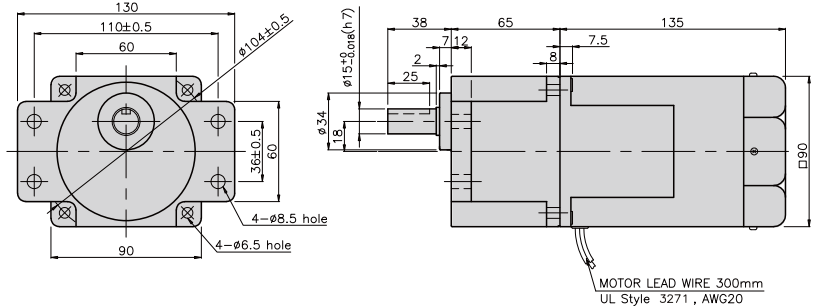

K9RP90F□ + K9P□BU

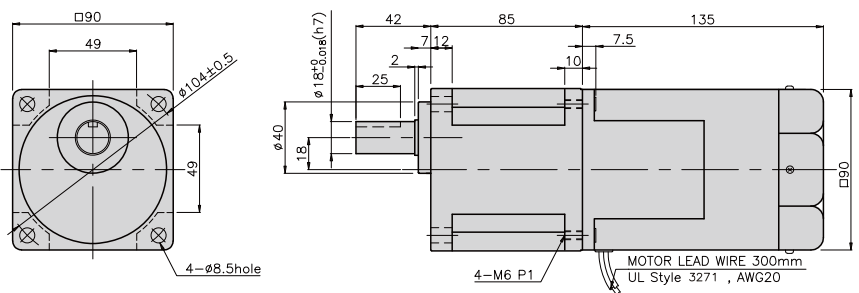

K9RP90F□ + K9P□BUF

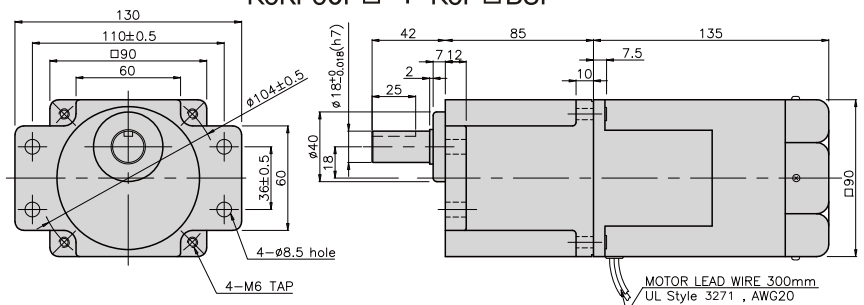

## GEARHEADS

### DIMENSIONS

K9RP90F□-T + K9P□B



K9RP90F□-T + K9P□BF, BUF



K9RP90F□-T + K9P□BU



K9RP90F□-T + K9P□B

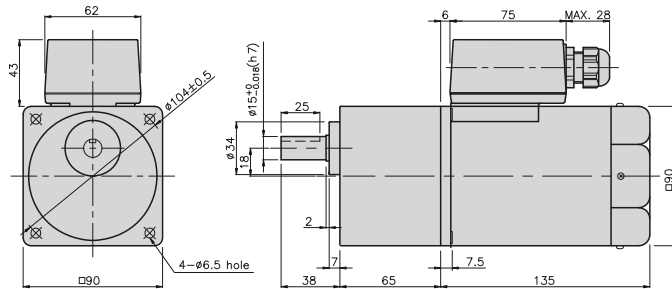

K9RP90F□-T + K9P□BF

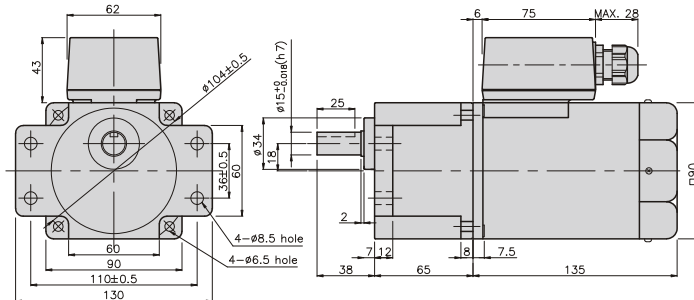

K9RP90F□-T + K9P□BU

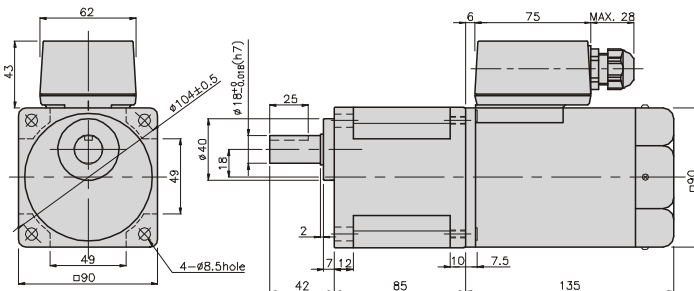

K9RP90F□-T + K9P□BUF

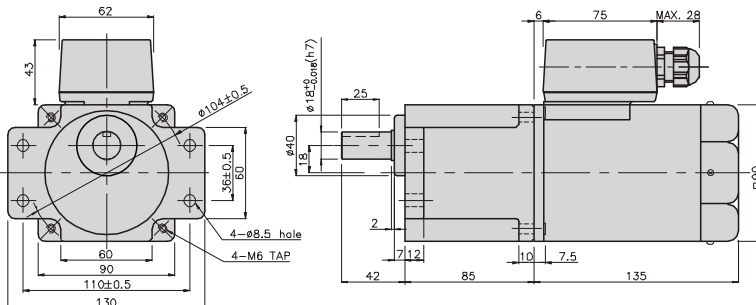

#### 무게

PART	WEIGHT(kg)
MOTOR	3.23
DECIMAL GEAR HEAD	0.62

#### 치수도표

품번	L	적용기종	취부 BOLT
01	65	K9P3~200B	M6 P1.0 X 95
02	40	K9P10BX	M6 P1.0 X 140

#### 무게

PART	WEIGHT(kg)
K9P3~10B	1.22
K9P12.5~20B	1.32
K9P25~60B	1.42
K9P75~200B	1.45

#### 치수도표

품번	L	적용기종	취부 BOLT
01	65	K9P3~200BF	M6 P1.0 X 25
02	40	K9P10BX	M6 P1.0 X 65

#### 무게

PART	WEIGHT(kg)
K9P3~10BF	1.22
K9P12.5~20BF	1.30
K9P25~60BF	1.42
K9P75~200BF	1.44

#### 치수도표

품번	L	적용기종	취부 BOLT
01	85	K9P3~200BU	M6 P1.0 X 20
02	40	K9P10BX	M6 P1.0 X 60

#### 무게

PART	WEIGHT(kg)
K9P3~10BU	1.44
K9P12.5~20BU	1.55
K9P25~60BU	1.69
K9P75~200BU	1.74

#### 치수도표

품번	L	적용기종	취부 BOLT
01	85	K9P3~200BUF	M6 P1.0 X 20
02	40	K9P10BX	M6 P1.0 X 65

#### 무게

PART	WEIGHT(kg)
K9P3~10BUF	1.50
K9P12.5~20BUF	1.62
K9P25~60BUF	1.76
K9P75~200BUF	1.82

## GEARHEADS

### DIMENSIONS

K9RP90F□-T5 + K9P□B



K9RP90F□-T5 + K9P□BF, BUF



K9RP90F□-T5 + K9P□BU



**무게**

PART	WEIGHT(kg)
MOTOR	3.23
DECIMAL GEAR HEAD	0.62

**치수도표**

품번	L	적용기종	취부 BOLT
O1	65	K9P3~200B	M6 P1.0 X 95
O2	40	K9P10BX	M6 P1.0 X 140

**무게**

PART	WEIGHT(kg)
K9P3~10B	1.22
K9P12.5~20B	1.32
K9P25~60B	1.42
K9P75~200B	1.45

**치수도표**

품번	L	적용기종	취부 BOLT
O1	65	K9P3~200BF	M6 P1.0 X 25
O2	40	K9P10BX	M6 P1.0 X 140

**무게**

PART	WEIGHT(kg)
K9P3~10BF	1.22
K9P12.5~20BF	1.30
K9P25~60BF	1.42
K9P75~200BF	1.44

**치수도표**

품번	L	적용기종	취부 BOLT
O1	85	K9P3~200BU	M6 P1.0 X 20
O2	40	K9P10BX	M6 P1.0 X 60

**무게**

PART	WEIGHT(kg)
K9P3~10BU	1.44
K9P12.5~20BU	1.55
K9P25~60BU	1.69
K9P75~200BU	1.74

**치수도표**

품번	L	적용기종	취부 BOLT
O1	85	K9P3~200BUF	M6 P1.0 X 20
O2	40	K9P10BX	M6 P1.0 X 65

**무게**

PART	WEIGHT(kg)
K9P3~10BUF	1.50
K9P12.5~20BUF	1.62
K9P25~60BUF	1.76
K9P75~200BUF	1.82

K9RP90F□-T5 + K9P□B

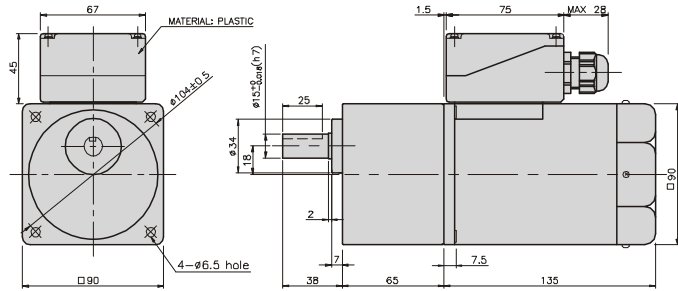

K9RP90F□-T5 + K9P□BF

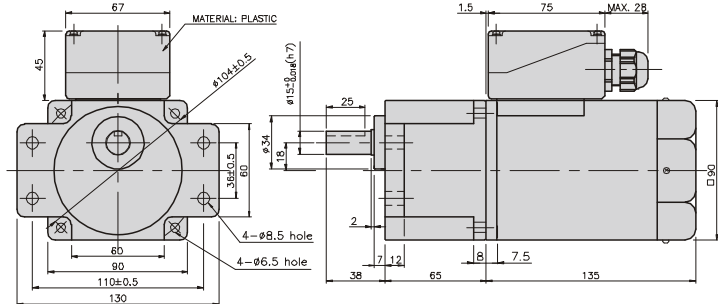

K9RP90F□-T5 + K9P□BU

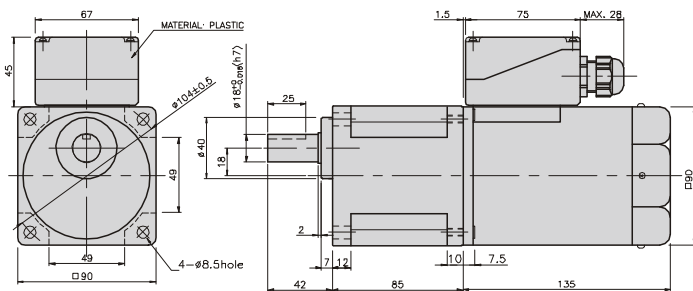

K9RP90F□-T5 + K9P□BUF

