

REVERSIBLE MOTOR

40W

□90mm

LEAD WIRE TYPE
TERMINAL BOX TYPE

K9RS40N□



K9RS40N□-T, T5



SPECIFICATIONS

40W 30분 정격, 4극

Model	Voltage (V)	Frequency (Hz)	Current (A)	Start T. (N*m/Kgf*cm)	Rated T. (N*m/Kgf*cm)	Speed (rpm)	Condenser (μF)
단상							
K9R□40NJ(-T, -T5)	100	50	1	0,3/3	0,315/3,15	1250	16
		60	1,13	0,33/3,3	0,255/2,55	1550	
K9R□40NU(-T, -T5)	110	60	0,8	0,2/2	0,26/2,6	1500	10
	115		0,83	0,22/2,2			
K9R□40NL(-T, -T5)	200	50	0,45	0,3/3	0,315/3,15	1250	4
		60	0,57		0,26/2,6	1500	
K9R□40NC(-T, -T5)	220	50	0,46	0,3/3	0,315/3,15	1250	3,5
		60	0,55	0,32/3,2	0,26/2,6	1500	
	230	50	0,55	0,4/4	0,315/3,15	1250	
		60	0,58	0,36/3,6	0,26/2,6	1500	
K9R□40ND(-T, -T5)	240	50	0,41	0,34/3,4	0,3/3	1300	3

* □ : SHAFT 형상(S : STRAIGHT, G : PINION)

RATED TORQUE OF GEARHEAD

● 50Hz

단위 = 상단 : N·m / 하단 : Kgfcm

Model	Speed(rpm)	500	416	300	250	200	166	150	120	100	83	75	60	50	41	37	30	25	20	16	15	12,5	10	8,3	7,5
Motor/ Gearhead	Ratio	3	3,6	5	6	7,5	9	10	12,5	15	18	20	25	30	36	40	50	60	75	90	100	120	150	180	200
K9R□40N□(-T, -T5) K9G□B(C)	0,73	0,87	1,22	1,46	1,82	2,19	2,43	3,04	3,65	4,37	4,37	5,47	6,56	7,87	8,75	10	10	10	10	10	10	10	10	10	10
	7,3	8,7	12,2	14,6	18,2	21,9	24,3	30,4	36,5	43,7	43,7	54,7	65,6	78,7	87,5	100	100	100	100	100	100	100	100	100	100

● 60Hz

단위 = 상단 : N·m / 하단 : Kgfcm

Model	Speed(rpm)	600	500	360	300	240	200	180	144	120	100	90	72	60	50	45	36	30	24	20	18	15	12	10	9
Motor/ Gearhead	Ratio	3	3,6	5	6	7,5	9	10	12,5	15	18	20	25	30	36	40	50	60	75	90	100	120	150	180	200
K9R□40N□(-T, -T5) K9G□B(C)	0,62	0,74	1,03	1,24	1,55	1,86	2,07	2,58	3,10	3,72	3,72	4,65	5,58	6,69	7,44	8,37	10	10	10	10	10	10	10	10	10
	6,2	7,4	10,3	12,4	15,5	18,6	20,7	25,8	31,0	37,2	37,2	46,5	55,8	66,9	74,4	83,7	100	100	100	100	100	100	100	100	100

- * GEARHEAD · DECIMAL GEARHEAD는 별매입니다.
- * GEARHEAD의 품명중 □에는 감속비가 들어갑니다.
- * ■ 색이 MOTOR와 같은 방향, 그 외에는 반대 방향입니다.
- * 표의 감속비보다 더 감속하고자 할 경우는 GEARHEAD와 MOTOR 사이에 감속비 10의 DECIMAL GEARHEAD를 설치할 수 있습니다. 이 경우의 허용 TORQUE는 10N·m/100kgfcm 입니다.
- * 회전수는 MOTOR의 동기 회전수(50Hz:1500rpm, 60Hz:1800rpm)를 기준으로 하여 감속비로 나누어서 계산하였습니다. 실제의 회전수는 부하의 크기에 따라서 표시된 수치보다 2~20% 적습니다.

GEARHEADS

DIMENSIONS

K9RS40N □

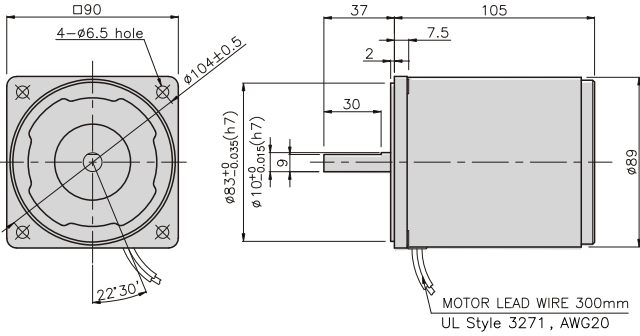

K9RS40N □-T

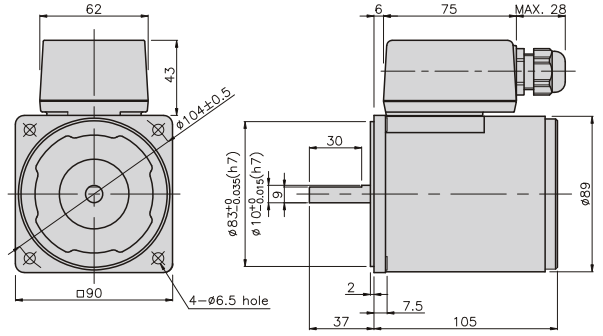

K9RS40N □-T5

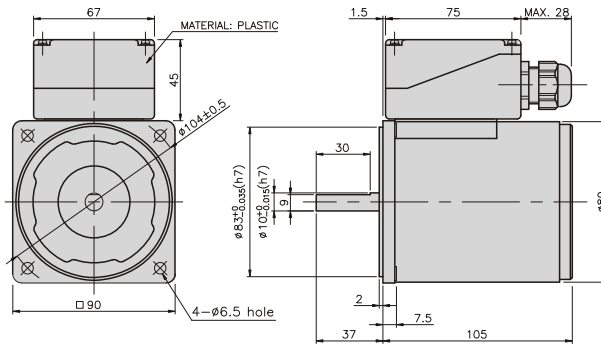

REVERSIBLE MOTORS

CONNECTION DIAGRAMS

K9RS40N □

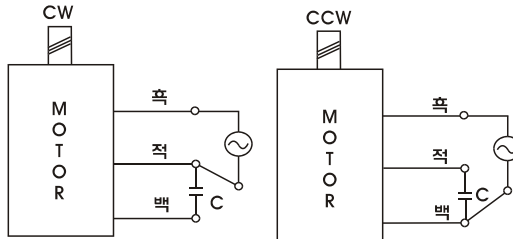

회전방향은 출력축에서 볼 경우

K9RS40N □-T

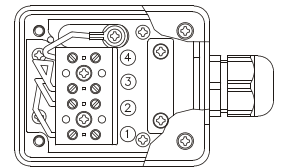
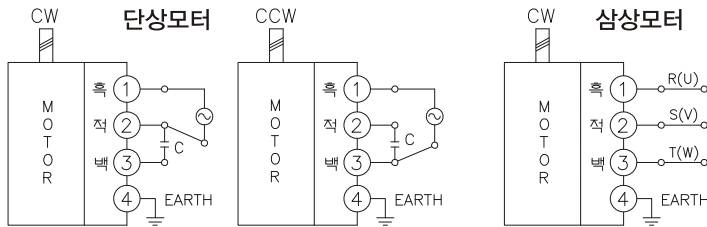

회전방향은 출력축에서 볼 경우

K9RS40N □-T5

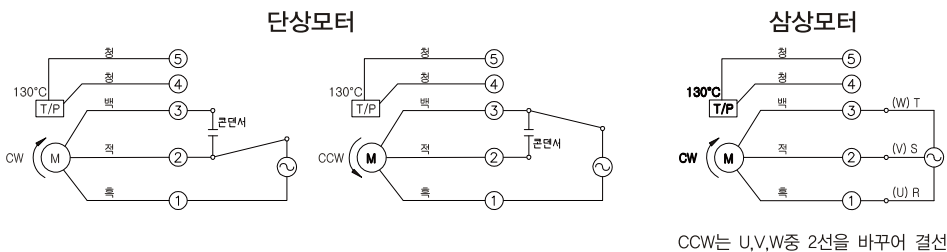

회전방향은 출력축에서 볼 경우

CCW는 U,V,W중 2선을 바꾸어 결선

GEARHEADS

DIMENSIONS

K9G□B(C)



DECIMAL GEARHEAD

K9G10BX

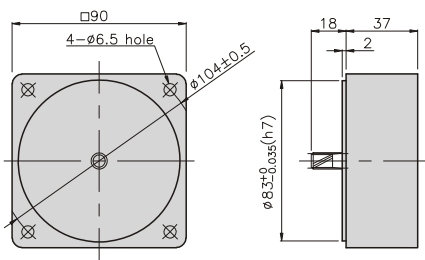

GEAR HEAD

K9G□B(C)

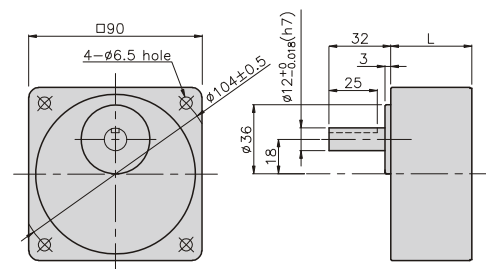

• KEY

• KEY GROOVE

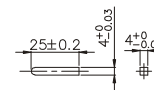

GEARHEADS

DIMENSIONS

K9RG40N□ + K9G□B(C)



K9RG40N□-T(-T5) + K9G□B(C)



치수도표

품번	L	적용기종	취부 BOLT
01	42	K9G3~18B(C)	M6 P1,0 X 65
02	60	K9G20~200B(C)	M6 P1,0 X 80
03	37	K9G10BX	M6 P1,0 X 120

무게

PART	WEIGHT(kg)	
MOTOR	2,40	
DECIMAL GEAR HEAD	0,60	
GEAR HEAD	K9G3~18B(C)	0,78
	K9G20~40B(C)	1,04
	K9G50~200B(C)	1,14

K9RG40N□ + K9G□B(C)

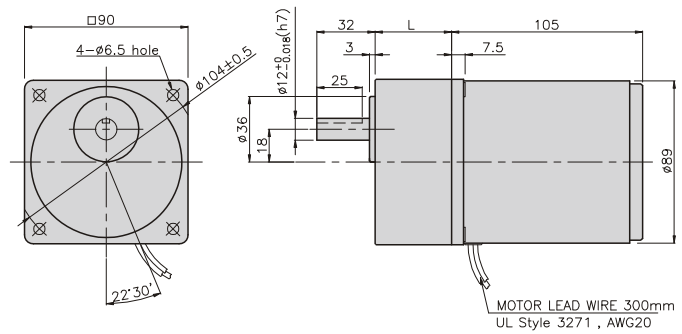

치수도표

품번	L	적용기종	취부 BOLT
01	42	K9G3~18B(C)	M5 P1,0 X 65
02	60	K9G20~200B(C)	M5 P1,0 X 80
03	37	K9G10BX	M5 P1,0 X 120

무게

PART	WEIGHT(kg)	
MOTOR	2,52	
DECIMAL GEAR HEAD	0,60	
GEAR HEAD	K9G3~18B(C)	0,78
	K9G20~40B(C)	1,04
	K9G50~200B(C)	1,14

K9RG40N□-T + K9G□B(C)

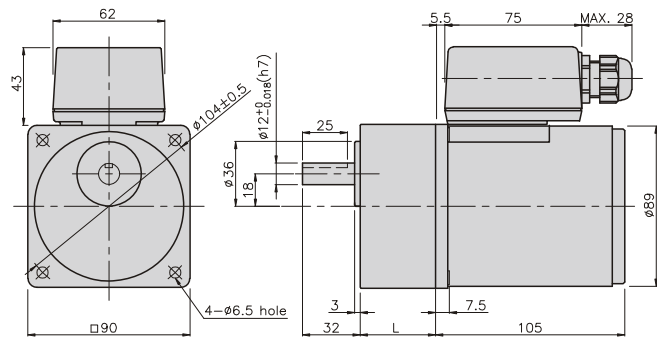

치수도표

품번	L	적용기종	취부 BOLT
01	42	K9G3~18B(C)	M5 P1,0 X 65
02	60	K9G20~200B(C)	M5 P1,0 X 80
03	37	K9G10BX	M5 P1,0 X 120

무게

PART	WEIGHT(kg)	
MOTOR	2,52	
DECIMAL GEAR HEAD	0,60	
GEAR HEAD	K9G3~18B(C)	0,78
	K9G20~40B(C)	1,04
	K9G50~200B(C)	1,14

K9RG40N□-T5 + K9G□B(C)

