

Brushless DC motor

- Product Number Code For Brushless DC Motor

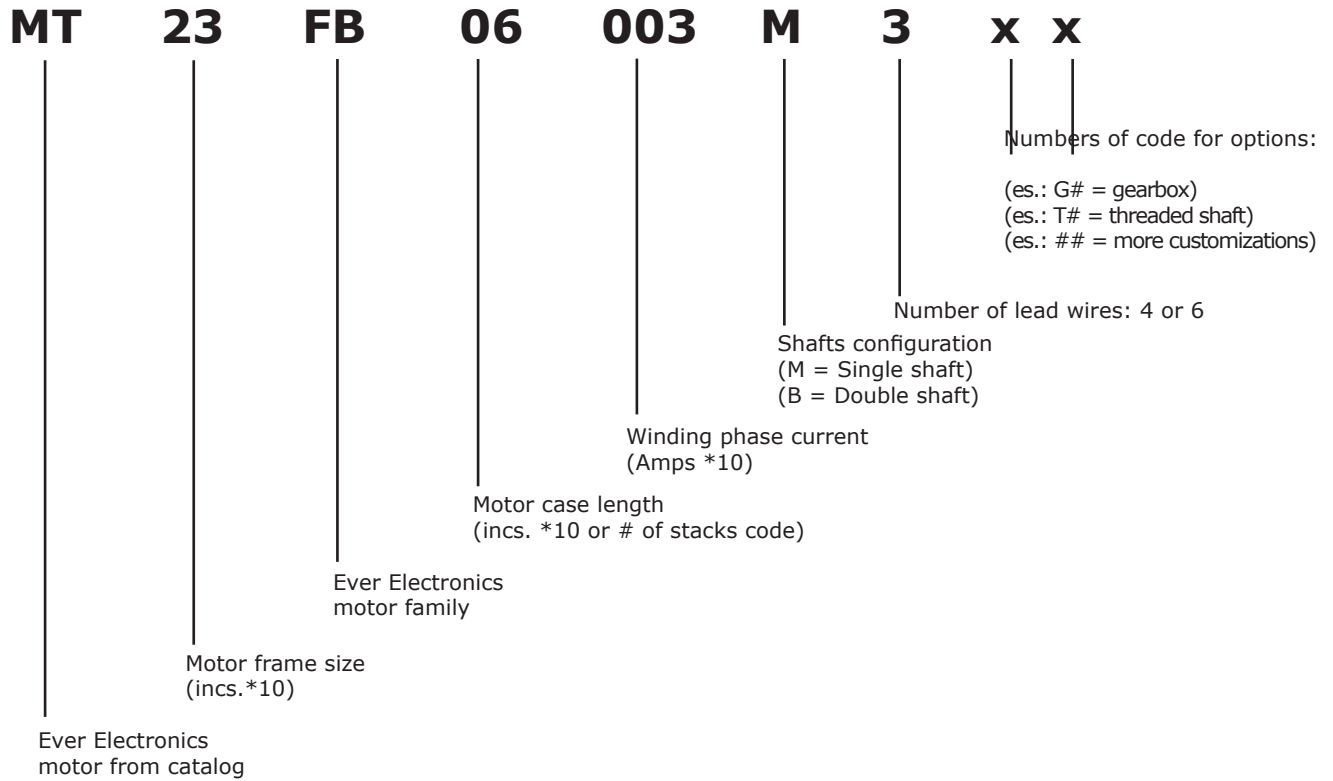

Brushless DC Motor

● Specification for Brushless DC Motor

Item	Specifications
Winding type	Star
Hall effect angle	120 degree electrical angle
Shaft run out	0.025 mm
Radial play	0.02 mm @ 450 g
End play	0.08 mm @ 450 g
Max. radial force	15 N @ 10 mm from the flange
Max. axial force	10 N
Insulation class	Class B
Dielectric strength	500 Vdc for one minute
Insulation resistance	100MΩ Min., 500 Vdc



● Electrical Specifications

Model No.	No. of poles	No. of phase	Rated Voltage	Rated Speed	Continuous Stall Torque	Reted Torque	Rated Power	Peak Torque	Peak Current	Line to line resistance	Line to line inductance	Torque constant	Rotor Inertia	Body Length	Mass
			Vdc	rpm	mNm	mNm	W	mNm	A	Ω	mH	mNm/A	gcm ²	mm	g
MT11FB10	4	3	15	8000	8.4	7	6	21	2.5	8	2	13.7	1.23	26	60
MT11FB15	4	3	24	10000	17	14.12	14.78	42.4	2.8	4.63	3	16	2.12	38	82
MT11FB30	4	3	24	3700	60	50	16	150	3	4.67	3.5	50	5.98	77	280

● Electric connection

Lead no.	Lead color	Lead gauge	Function	Description
1	Yellow	UL1007 26AWG	Vcc	Supply voltage for hall sensors
2	Blue		Hall A	
3	Orange		Hall B	
4	Brown		Hall C	
5	White		GND	Ground for hall sensors
6	Green		Phase U	
7	Red		Phase V	
8	Black		Phase W	

● Dimensions

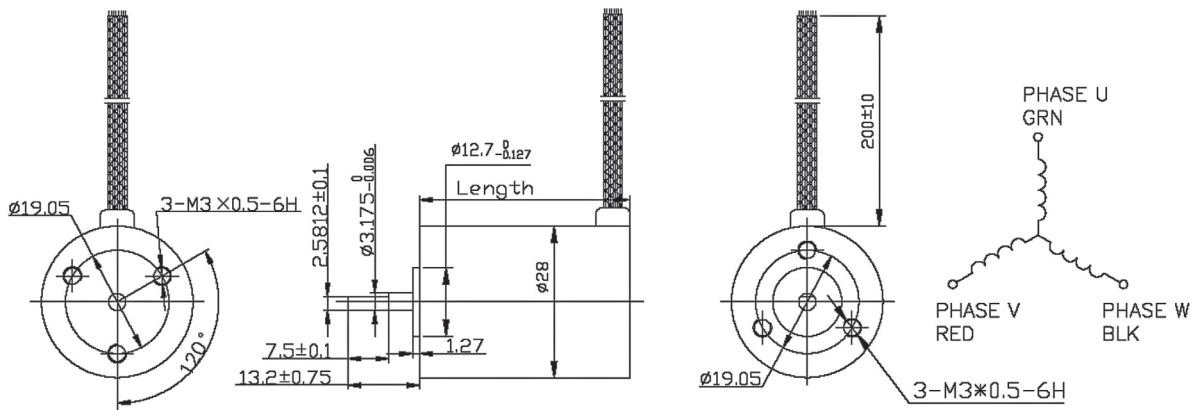

Brushless DC Motor

● Specification for Brushless DC Motor

Item	Specifications
Winding type	Star
Hall effect angle	120 degree electrical angle
Shaft run out	0.025 mm
Radial play	0.02 mm @ 450 g
End play	0.08 mm @ 450 g
Max. radial force	15 N @ 10 mm from the flange
Max. axial force	10 N
Insulation class	Class B
Dielectric strength	500 Vdc for one minute
Insulation resistance	100M Ω Min., 500 Vdc

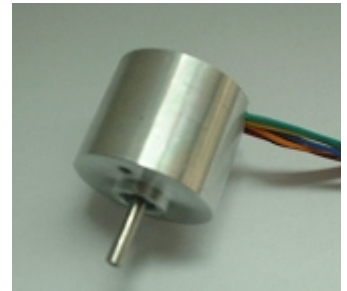

● Electrical Specifications

Model No.	No. of poles	No. of phase	Rated Voltage	Rated Speed	Continuous Stall Torque	Reted Torque	Rated Power	Peak Torque	Peak Current	Line to line resistance	Line to line inductance	Torque constant	Rotor Inertia	Body Length	Mass
			Vdc	rpm	mNm	mNm	W	mNm	A	Ω	mH	mNm/A	gcm ²	mm	g
MT13FB12	4	3	36	4000	14	12	4	35	0.64	29.2	11.83	18.75	7.95	29	85

● Electric connection

Lead no.	Lead color	Lead gauge	Function	Description
1	Yellow	UL1007 26AWG	Vcc	Supply voltage for hall sensors
2	Blue		Hall A	
3	Orange		Hall B	
4	Brown		Hall C	
5	White		GND	Ground for hall sensors
6	Green		Phase U	
7	Red		Phase V	
8	Black		Phase W	

● Dimensions

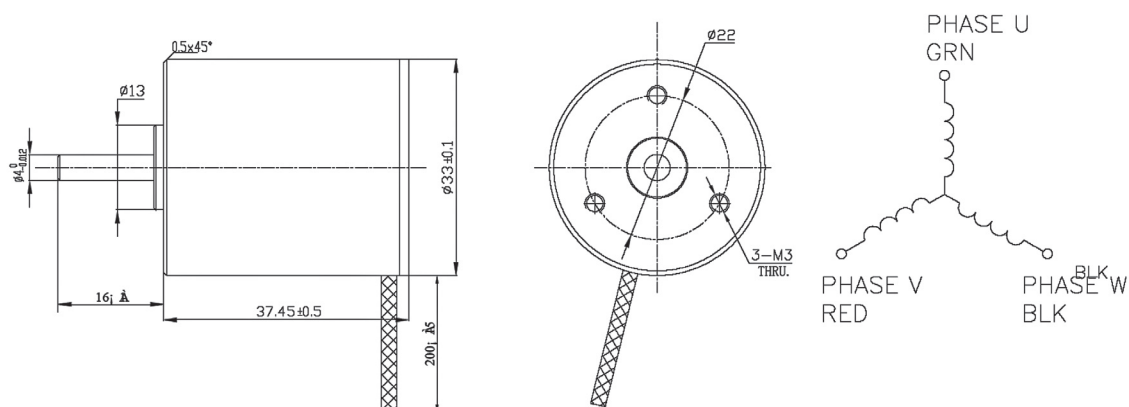

Brushless DC Motor

● Specification for Brushless DC Motor

Item	Specifications
Winding type	Delta
Hall effect angle	120 degree electrical angle
Shaft run out	0.025 mm
Radial play	0.02 mm @ 450 g
End play	0.08 mm @ 450 g
Max. radial force	28 N @ 20 mm from the flange
Max. axial force	10 N
Insulation class	Class B
Dielectric strength	500 Vdc for one minute
Insulation resistance	100MΩ Min., 500 Vdc

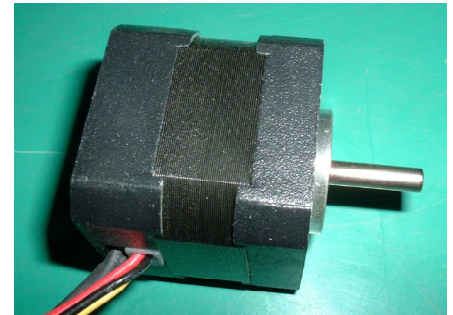

● Electrical Specifications

Model No.	No. of poles	No. of phase	Rated Voltage	Rated Speed	Continuous Stall Torque	Reted Torque	Rated Power	Peak Torque	Peak Current	Line to line resistance	Line to line inductance	Torque constant	Back E.M.F.	Rotor Inertia	Body Length	Mass
			Vdc	rpm	Nm	Nm	W	Nm	A	Ω	mH	Nm/A	V/Krpm	gcm ²	mm	Kg
MT17FB17054M3	8	3	24	4000	0.075	0.0625	26	0.19	5.4	1.8	2.6	0.035	3.66	24	41	0.3
MT17FB24106M3	8	3	24	4000	0.15	0.125	52.5	0.38	10.6	0.8	1.2	0.0355	3.72	48	61	0.45
MT17FB32155M3	8	3	24	4000	0.22	0.185	77.5	0.56	15.5	0.55	0.8	0.036	3.76	72	81	0.65
MT17FB40200M3	8	3	24	4000	0.3	0.25	105	0.75	20	0.28	0.54	0.0376	3.94	96	100	0.8

● Electric connection

Lead no.	Lead color	Lead gauge	Function	Description
1	Red	UL1007 26AWG	Vcc	Supply voltage for hall sensors
2	Blue		Hall A	
3	Green		Hall B	
4	White		Hall C	
5	Black		GND	Ground for hall sensors
6	Yellow	UL1007 20AWG	Phase U	
7	Red		Phase V	
8	Black		Phase W	

● Dimensions

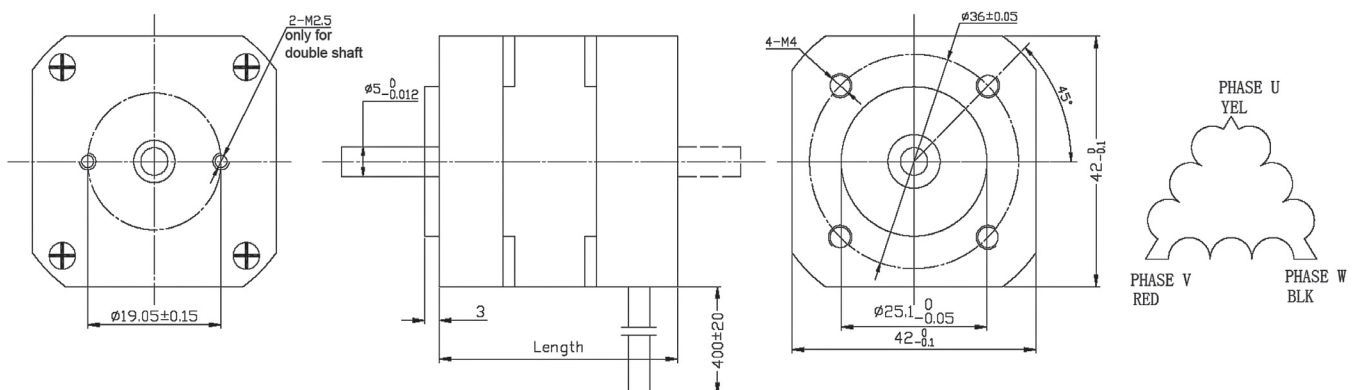

Brushless DC Motor

● Specification for Brushless DC Motor

Item	Specifications
Winding type	Delta
Hall effect angle	120 degree electrical angle
Shaft run out	0.025 mm
Radial play	0.025 mm @ 460 g
End play	0.025 mm @ 4000 g
Max. radial force	75 N @ 20 mm from the flange
Max. axial force	15 N
Insulation class	Class B
Dielectric strength	500 Vdc for one minute
Insulation resistance	100MΩ Min., 500 Vdc

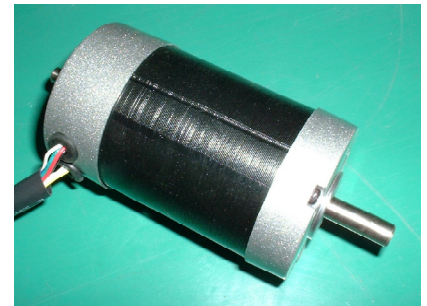

● Electrical Specifications

Model No.	No. of poles	No. of phase	Rated Voltage	Rated Speed	Rated Torque	Rated Power	Peak Torque	Peak Current	Line to line resistance	Line to line inductance	Torque constant	Back E.M.F.	Rotor Inertia	Body Length	Mass
			Vdc	rpm	Nm	W	Nm	A	Ω	mH	Nm/A	V/Krpm	gcm ²	mm	Kg
MT23FB18035M3(S)	4	3	36	4000	0.055	23	0.16	3.5	4.1	10	0.053	5.55	30	45	0.25
MT23FB22068M3(S)	4	3	36	4000	0.11	46	0.39	6.8	1.5	4.2	0.063	6.6	75	55	0.5
MT23FB30115M3(S)	4	3	36	4000	0.22	92	0.7	11.5	0.7	2.16	0.063	6.6	119	75	0.75
MT23FB38165M3(S)	4	3	36	4000	0.32	133	1	16.5	0.45	1.4	0.063	6.6	173	95	1
MT23FB46205M3(S)	4	3	36	4000	0.43	180	1.27	20.5	0.35	1	0.063	6.6	230	115	1.25

● Electric connection

Lead no.	Lead color	Lead gauge	Function	Description
1	Red	UL1007 26AWG	Vcc	Supply voltage for hall sensors
2	Blue		Hall A	
3	Green		Hall B	
4	White		Hall C	
5	Black		GND	
6	Yellow	UL1007 20AWG	Phase U	
7	Red		Phase V	
8	Black		Phase W	

● Dimensions

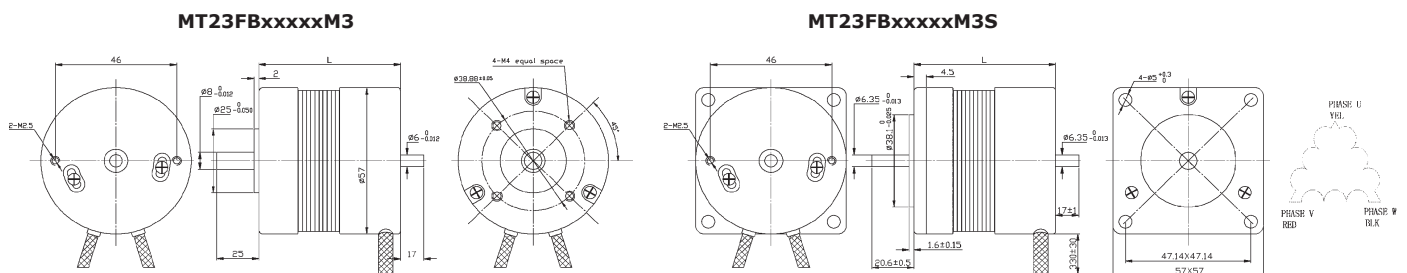

Brushless DC Motor

● Specification for Brushless DC Motor

Item	Specifications
Winding type	Delta
Hall effect angle	120 degree electrical angle
Shaft run out	0.025 mm
Radial play	0.025 mm @ 460 g
End play	0.025 mm @ 4000 g
Max. radial force	75 N @ 20 mm from the flange
Max. axial force	15 N
Insulation class	Class B
Dielectric strength	500 Vdc for one minute
Insulation resistance	100M Ω Min., 500 Vdc

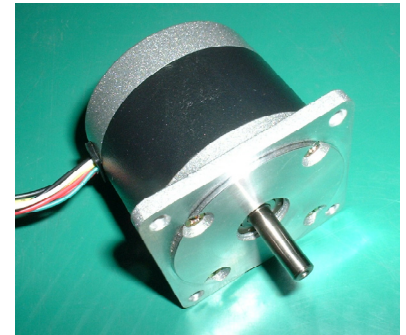

● Electrical Specifications

Model No.	No. of poles	No. of phase	Rated Voltage	Rated Speed	Reted Torque	Rated Power	Peak Torque	Peak Current	Line to line resistance	Line to line inductance	Torque constant	Back E.M.F.	Rotor Inertia	Body Length	Mass
			Vdc	rpm	Nm	W	Nm	A	Ω	mH	Nm/A	V/Krpm	gcm ²	mm	Kg
MT23FB20115M3SH	4	3	24	2300	0.24	58	0.55	11.5	1.5	1.8	0.05	5.2	200	52	0.65

● Electric connection

Lead no.	Lead color	Lead gauge	Function	Description
1	Red	UL1007 26AWG	Vcc	Supply voltage for hall sensors
2	Blue		Hall A	
3	Green		Hall B	
4	White		Hall C	
5	Black		GND	Ground for hall sensors
6	Yellow	UL1007 20AWG	Phase U	
7	Red		Phase V	
8	Black		Phase W	

● Dimensions

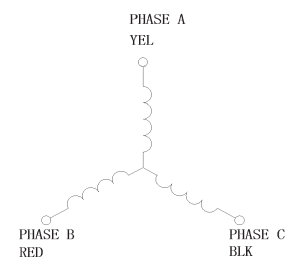
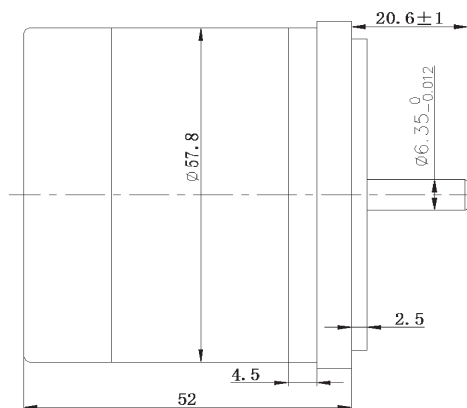
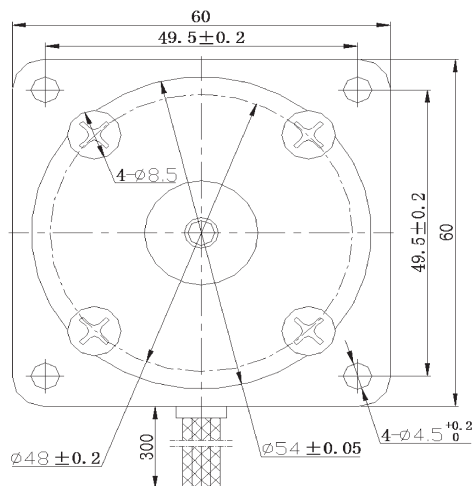

Brushless DC Motor

● Specification for Brushless DC Motor

Item	Specifications
Winding type	Delta
Hall effect angle	120 degree electrical angle
Shaft run out	0.05 mm
Radial play	0.02 mm @ 450 g
End play	0.02 mm @ 450 g
Max. radial force	220 N @ 20 mm from the flange
Max. axial force	60 N
Insulation class	Class B
Dielectric strength	500 Vdc for one minute
Insulation resistance	100MΩ Min., 500 Vdc

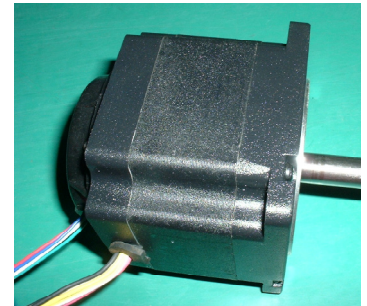

● Electrical Specifications

Model No.	No. of poles	No. of phase	Rated Voltage	Rated Speed	Rated Torque	Rated Power	Peak Torque	Peak Current	Line to line resistance	Line to line inductance	Torque constant	Back E.M.F.	Rotor Inertia	Body Length	Mass
			Vdc	rpm	Nm	W	Nm	A	Ω	mH	Nm/A	V/Krpm	gcm ²	mm	Kg
MT34FB23110M3	8	3	48	3000	0.35	110	1.05	11	1.05	2.2	0.10	10.5	400	58	1.5
MT34FB28190M3	8	3	48	3000	0.7	220	2.1	19	0.36	1.05	0.11	11.5	800	71	1.85
MT34FB39330M3	8	3	48	3000	1.4	440	4.2	33	0.2	0.48	0.13	13.5	1600	98	2.6
MT34FB50550M3	8	3	48	3000	2.1	660	6.3	55	0.16	0.3	0.11	11.5	2400	125	4.0

● Electric connection

Lead no.	Lead color	Lead gauge	Function	Description
1	Red	UL1007 26AWG	Vcc	Supply voltage for hall sensors
2	Blue		Hall A	
3	Green		Hall B	
4	White		Hall C	
5	Black		GND	
6	Yellow	UL3266 20AWG	Phase U	
7	Red		Phase V	
8	Black		Phase W	

● Dimensions

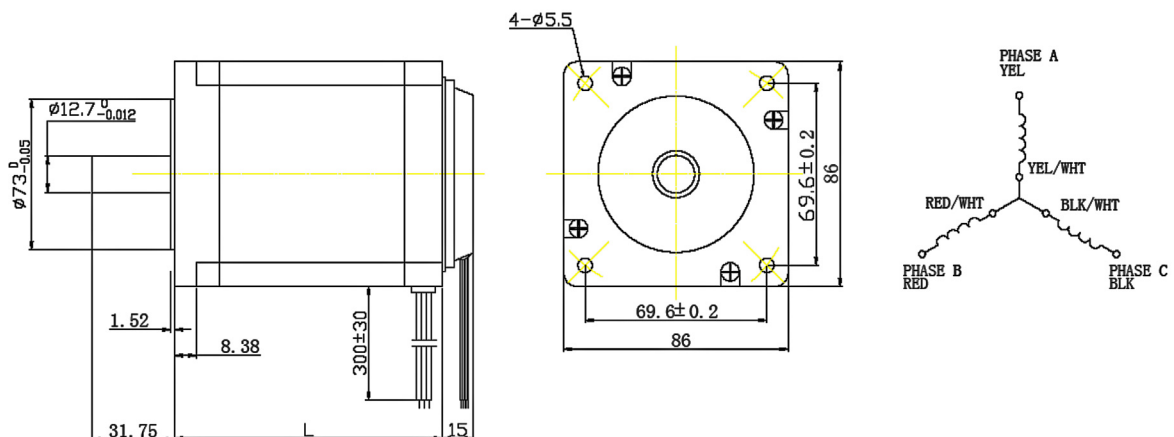

Brushless DC Motor with integrated electronics

● Specification for Brushless DC Motor with integrate electronics

Item	Specifications
Winding type	Delta
Hall effect angle	120 degree electrical angle
Shaft run out	0.025 mm
Radial play	0.02 mm @ 450 g
End play	0.08 mm @ 450 g
Max. radial force	28 N @ 20 mm from the flange
Max. axial force	10 N
Insulation class	Class B
Dielectric strength	500 Vdc for one minute
Insulation resistance	100MΩ Min., 500 Vdc

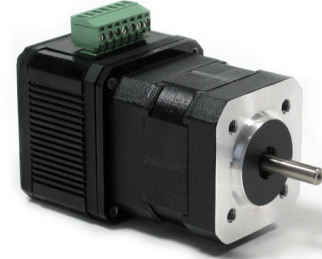

● Electrical Specifications

Model No.	No. of poles	No. of phase	Rated Voltage	Rated Speed	Reted Torque	Rated Power	Peak Torque	Peak Current	Line to line resistance	Line to line inductance	Torque constant	Back E.M.F.	Rotor Inertia	Body Length	Mass
			Vdc	rpm	Nm	W	Nm	A	Ω	mH	Nm/A	V/Krpm	gcm ²	mm	Kg
MT42BL01-IE	8	3	24	4000	0.0625	26	0.19	5.4	1.75	2.10	0.034	2.78	24	77	0.90
MT42BL02-IE	8	3	24	4000	0.125	52	0.38	10.6	0.80	1.20	0.0355	2.90	48	97	1.05
MT42BL03-IE	8	3	24	4000	0.185	78	-	-	0.46	0.70	0.038	3.10	72	137	1.25
MT42BL04-IE	8	3	24	4000	0.250	104	-	-	0.28	0.54	0.0376	3.07	96	157	1.40

● Electric connection

Pin no.	Connector	Signal	Description
1		+ 5 V	5 Volt output
2		F / R	Rotating direction (Hi=CW)
3		SV	Speed voltage 0 ÷ 5 Vdc
4		PG	Speed pulse output (TTL), 24 pulse/rev
5		GND	Common ground of system
6		GND	Common ground of system
7		+ Vp	DC power input +24 Vdc

● Dimensions

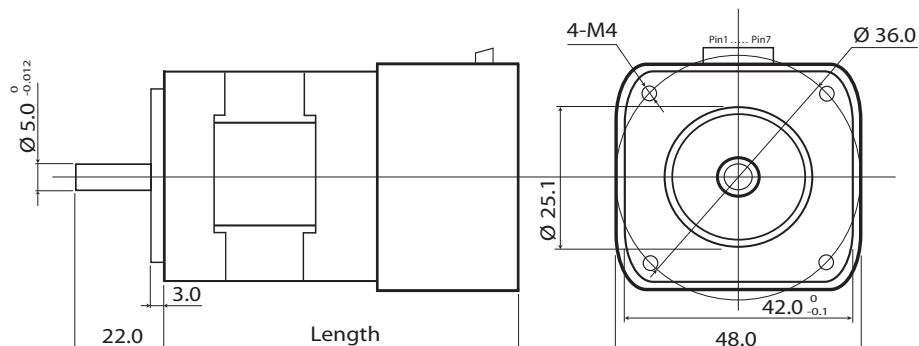

Brushless DC Motor with integrated electronics

● Specification for Brushless DC Motor with integrate electronics

Item	Specifications
Winding type	Delta
Hall effect angle	120 degree electrical angle
Shaft run out	0.025 mm
Radial play	0.025 mm @ 450 g
End play	0.025 mm @ 450 g
Max. radial force	75 N @ 20 mm from the flange
Max. axial force	15 N
Insulation class	Class B
Dielectric strength	500 Vdc for one minute
Insulation resistance	100M Ω Min., 500 Vdc



● Electrical Specifications

Model No.	No. of poles	No. of phase	Rated Voltage	Rated Speed	Reted Torque	Rated Power	Peak Torque	Peak Current	Line to line resistance	Line to line inductance	Torque constant	Back E.M.F.	Rotor Inertia	Body Length	Mass
			Vdc	rpm	Nm	W	Nm	A	Ω	mH	Nm/A	V/Krpm	gcm ²	mm	Kg
MT57BL01-IE	4	3	36	4000	0.110	46	0.16	5.4	1.50	4.50	0.063	5.10	30	102	1.00
MT57BL02-IE	4	3	36	4000	0.220	92	0.39	10.6	0.60	2.10	0.063	5.10	75	122	1.25
MT57BL03-IE	4	3	36	4000	0.320	134	0.55	9.0	0.45	1.65	0.061	4.90	119	162	1.50
MT57BL04-IE	4	3	36	4000	0.440	184	-	-	0.38	1.00	0.063	5.10	230	182	2.00

● Electric connection

Pin no.	Connector	Signal	Description
1		+ 5 V	5 Volt output
2		F / R	Rotating direction (Hi=CW)
3		SV	Speed voltage 0 ÷ 5 Vdc
4		PG	Speed pulse output (TTL), 24 pulse/rev
5		GND	Common ground of system
6		GND	Common ground of system
7		+ Vp	DC power input +36 Vdc

● Dimensions

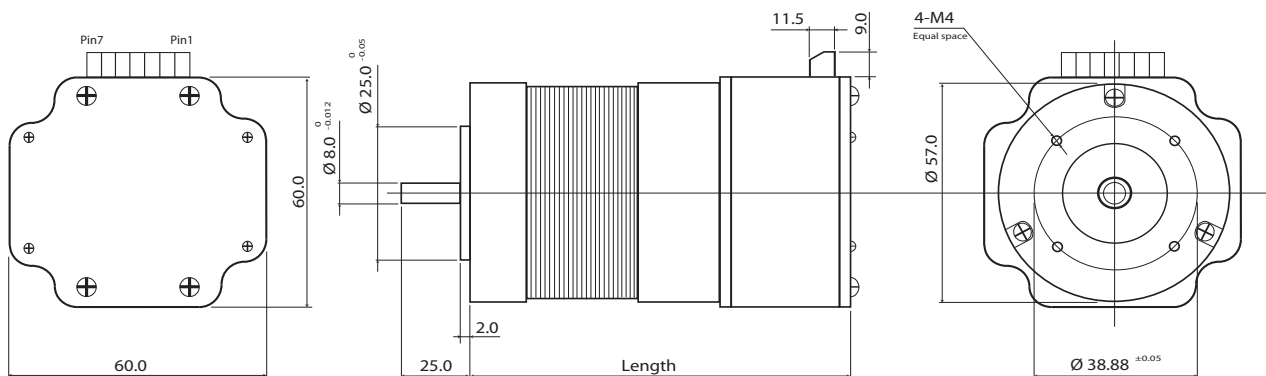

Gearbox Size 57mm Brushless DC Motor

- General Specification for Gearbox Size 57mm Brushless DC Motor

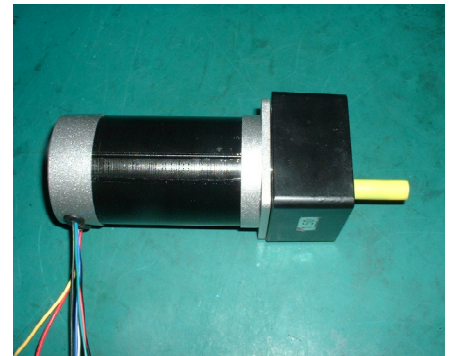

- Gearbox Size 57mm Brushless DC Motor Specifications**

The motor winding specifications are the same of the Brushless DC Motor Family (MT23FB series).

- Gearbox Specifications**

Ratio	3	7.5	12.5	15	25	30	50	75	90	100	120	150
Number of gear trains	2	2	2	3	3	3	4	4	5	5	5	5
Length (L) mm	32	32	32	32	42	42	42	42	42	42	42	42
Peak torque Kg.cm	50											
Average Backlash at Noload	4 deg			3.5 deg			3 deg			2.5 deg		

- Dimension**

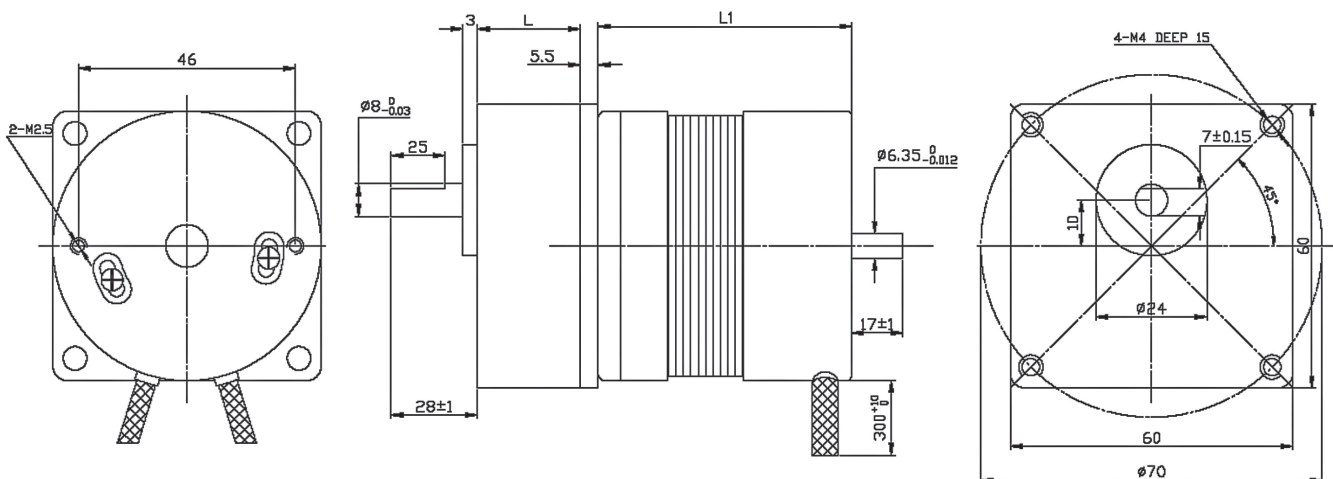

L1 can be 45mm, 55mm, 95mm and 115mm

Gearbox Size 86mm Brushless DC Motor

- **General Specification for Gearbox Size 86mm Brushless DC Motor**

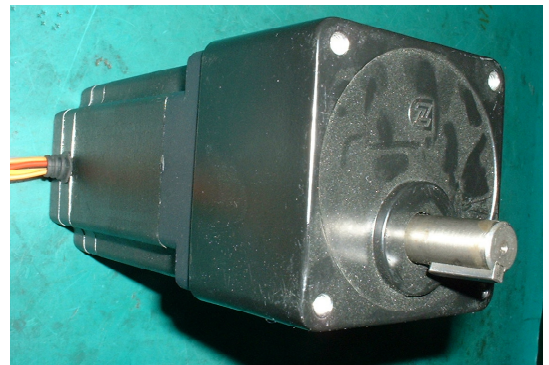

- **Gearbox Size 86mm Brushless DC Motor Specifications**

The motor winding specifications are the same of the Brushless DC Motor Family (MT34FB series).

- **Gearbox Specifications**

Ratio	3	5	7.5	12.5	15	25	30	50	75	100	120	150
Number of gear trains	2	2	2	2	2	3	3	4	4	4	4	4
Length (L) mm	45	45	45	45	45	60	60	60	60	60	60	60
Peak torque Kg.cm	250											
Average Backlash at Noload	4 deg					3.5 deg			2.5 deg			

- **Dimension**

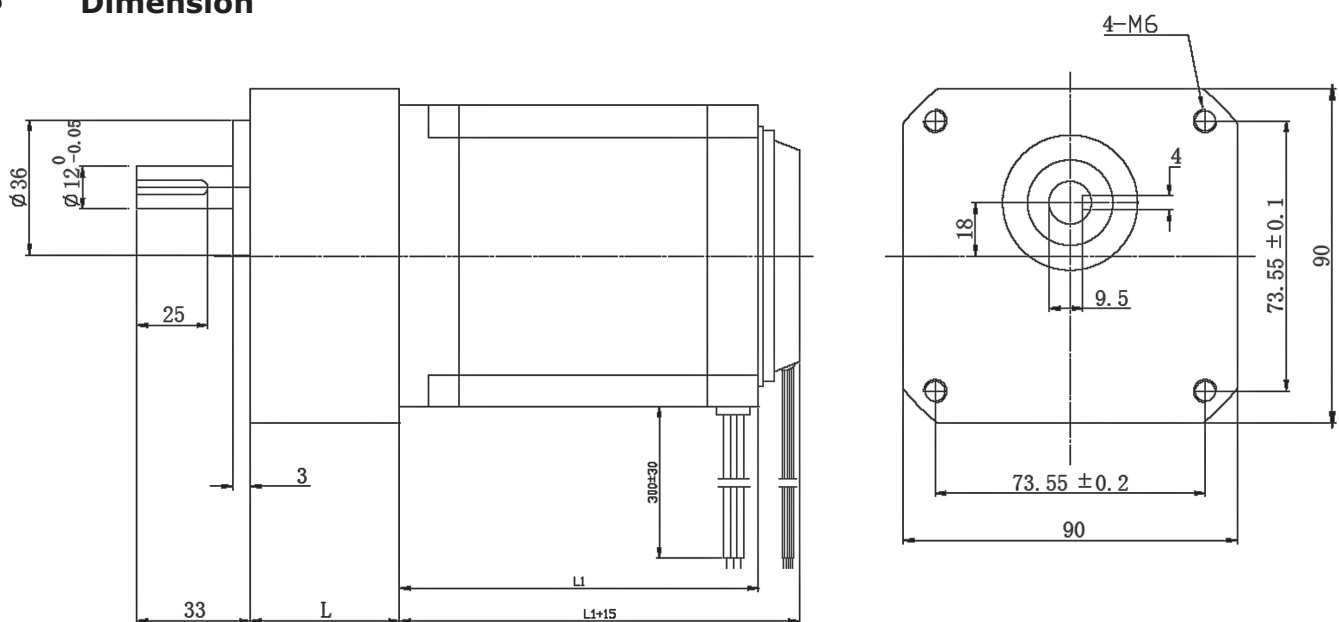

L1 can be 56mm, 69mm, 96mm and 123mm