

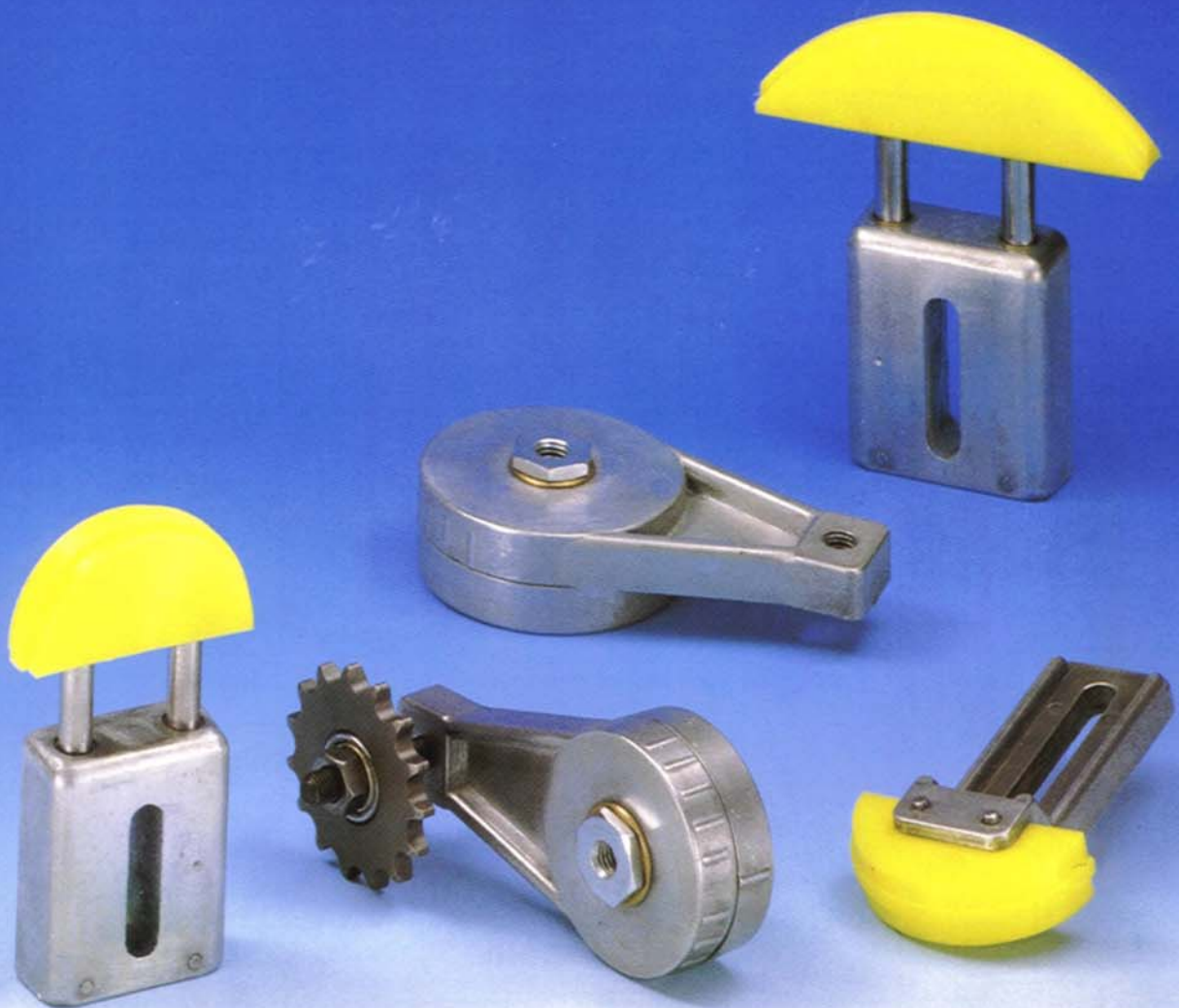

CROSS+MORSE

Power Transmission Solutions



Tensioners



Cross Tensioners provide constant belt or chain tension. Their automatic tensioning action translates into improved performance and extended life for most types of fixed-centre drives. Additionally, the built-in spring mechanism acts as a buffer, absorbing momentary overloads and reducing vibration. Tensioners are available in a number of sizes and mounting styles, ideally suited for drives on agricultural machinery, off-road vehicles, conveyors, packaging machinery, printing presses and many other industrial applications. Precision construction and high-quality materials are combined for a superior product with proven durability in the toughest environments. Tensioners can be supplied as base units for adaption by customer, or as complete assemblies with chain sprockets/guides for roller chain applications. There are two basic designs of tensioners available; the Rotary Tensioner and the Linear Tensioner.

Rotary Tensioner Type RT

Rotary Tensioners provide a full 90° of useable tensioning action. This unique design conserves space and simplifies tensioning adjustment. The fully automatic takeup action is achieved by using multiple alloy steel compression springs completely captivated within the body of the tensioner. There are no exposed moving parts that can cause injury or jam under adverse conditions. Both body members are high quality aluminium diecastings fitted with oil-impregnated sintered bronze bearings. They are ideally suited for use on outdoor equipment, operating reliably at both high and low temperatures. For extremely corrosive applications, units with stainless steel springs can also be supplied. Levels of tension can be set with aid of the adjustment marks on the rim of the rotating arm. For additional positional security a 6mm diameter locking pin hole is provided on the rear mounting face. The basic tensioner is combined with roller chain idler sprockets for a standard range of chain tensioners, see series CRT.

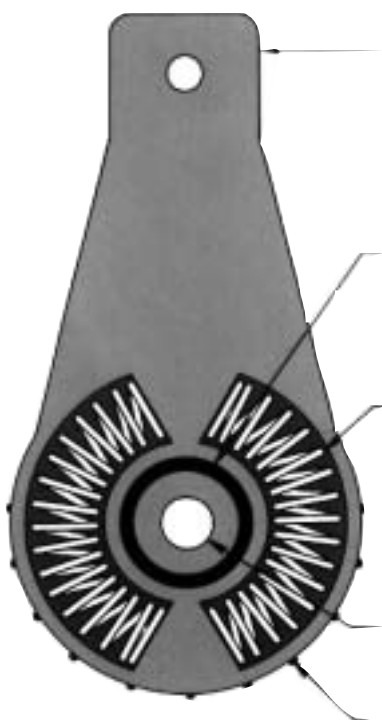

Frames

All structural members are made of high-strength diecast aluminium material. Heavy wall sections and/or ribbing prevents deflection under eccentric loads. All mounting surfaces and bearing seats are fully machined.

Bearings

Oil-impregnated, sintered bronze bearings are used to provide smooth, reliable movement at all wear points. Bearings are press-fitted in position and never require lubrication.

Springs

Tensioning action is provided by the use of multiple compression springs. These springs are made from alloy steel accurately wound to tight manufacturing tolerances to provide consistent tensioning force. Springs are grease-lubricated for long life and quiet operation.

Mounting Holes

Only a single bolt is required for mounting and tension adjustment.

Adjustment Marks

Enable easy setting of tension.

Linear Tensioner Type LT

Linear Tensioners provide fully automatic straight-line takeup for all types of drive mechanisms. Each unit consists of a rectangular aluminium diecasting which houses two hardened and ground steel reciprocating shafts which are outwardly spring-loaded. The shafts are attached to a triangular mounting block. All components are made of metal; there are no rubber elements to stretch or cold flow when exposed to harsh operating conditions. Use of sintered bronze oil-impregnated bearings assures long trouble-free life with no need for maintenance. For extremely corrosive applications, units fitted with stainless steel shafts and springs are available. To provide a standard series of chain tensioners, series CLT the triangular mounting block is replaced by polyethylene chain guides. Two series are available, the standard with 89mm radii guides for smooth operation, and a compact series with reduced radii guides for when space is limited. For applications where rigid adjustment is preferred tensioners type CT can be used.

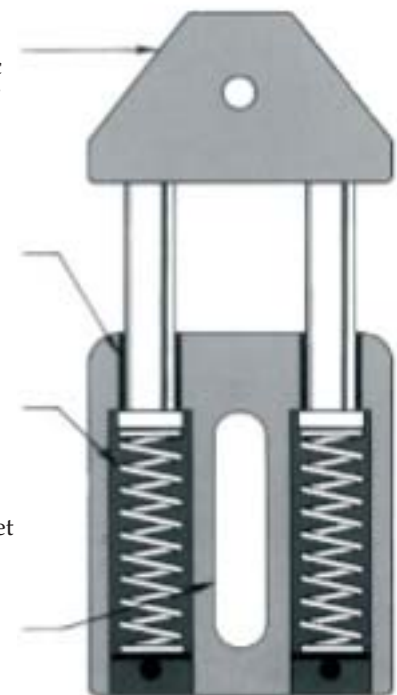

Cross Tensioners



Rotary Tensioner - Series RT

Provides up to 90° useable tensioning action.

A blind hole is provided in the mounting face to enable location with a pin in the framework if rapid positioning of the tensioner is required.

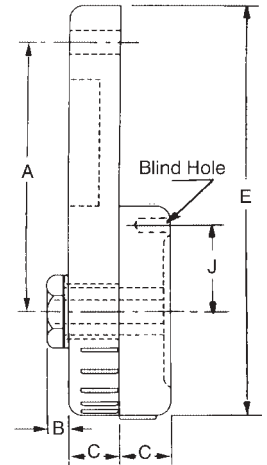
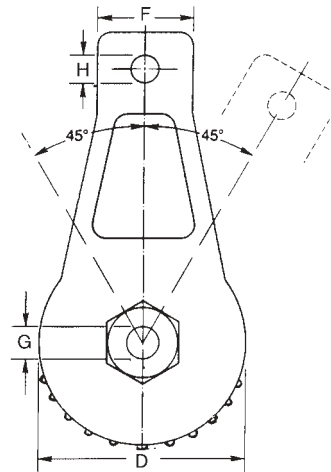

Blind Hole 9mm deep
6mm Ø RT 1000 Series
8mm Ø RT 2000 Series

Cat. No.	Torque Range	A	B	C	D	E	F	G	H	J
RT1001	8-18 Nm	88.9	5.6	15.0	70	136	30	3/8" UNC	M10	29.5
RT1002	8-18 Nm	88.9	5.6	15.0	70	136	30	3/8" UNC	10	29.5
RT2001	20-34 Nm	101.6	6.9	17.5	92	160	37	1/2" UNC	1/2" UNC	36.0
RT2002	20-34 Nm	101.6	6.9	17.5	92	160	37	1/2" UNC	13	36.0

RT Series incorporate adjustment marks every 15 degrees to enable simple setting.

Linear Tensioner - Series LT

Provides up to 43mm linear adjustment with accurate control.

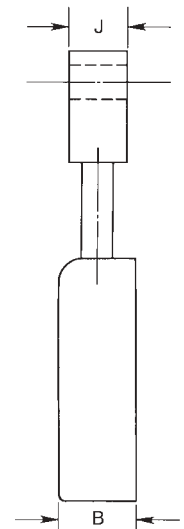
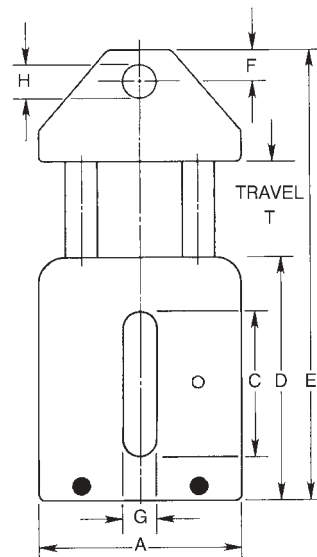

Cat. No.	Spring Force N	Travel T	A	B	C	D	E min	E max	F	G	H	J	T
LT1002	66-178	29	60	25	48	75	111	140	10	10.5	9.9	20	29
LT2002	89-267	31	75	30	60	90	144	175	12	12.5	13.0	25	31
LT3002	155-400	43	90	35	75	108	167	210	14	14.5	13.0	30	43

All dimensions are in mm except where indicated.

LT Series can be supplied with hole 'H' tapped to 3/8" UNC (LT 1000 Series) or 1/2" UNC (LT 2000 and 3000 Series).

Tel +44(0) 121 360 0155

Fax +44(0) 121 325 1079

Email sales@crossmorse.com

Rotary Chain Tensioners



Suitable for Simplex, Duplex and Triplex Chain Drives for British Standard Roller Chains

Sprung loaded chain tensioners can extend the life of roller chain on fixed centre drives by more than 30%, particularly where centre distance exceeds 40 times chain pitch. They can be used for drives operating in either direction providing a smoother drive, self tensioned and so are virtually maintenance-free. Of robust construction the chain tensioners provide an angular movement of 45°. A blind location hole is machined on the mounting face at radius J, diametrically opposite the adjustment indicator. Although not required for normal operation of the tensioner, the location hole can be used, with a corresponding pin in the framework, for quick positioning or additional torque resistance.

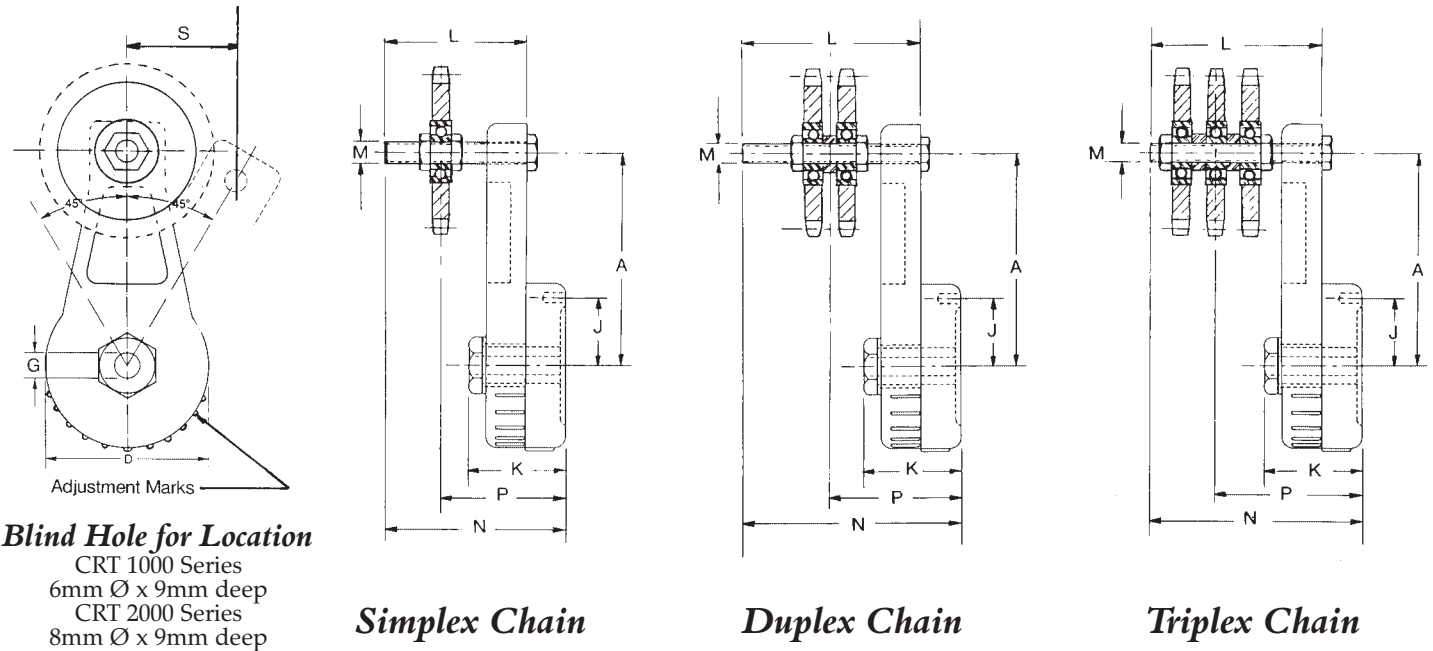

Tensioner Cat. No.	Torque Range Nm	Chain Size	No. Teeth Idler Z	A	D	G	J	K	L	M	N	P	S
SIMPLEX CHAIN													
CRT1106	8-18	06B-1	15	88.9	70	3/8" UNC	29.5	35.5	60	M10	75	40-63	63
CRT1108	8-18	08B-1	15	88.9	70	3/8" UNC	29.5	35.5	60	M10	75	42-63	63
CRT1110	8-18	10B-1	15	88.9	70	3/8" UNC	29.5	35.5	80	M10	95	43-83	63
CRT2112	20-34	12B-1	15	101.6	92	1/2" UNC	36.0	42.0	76	1/2" UNC	94	50-80	72
CRT2116	20-34	16B-1	13	101.6	92	1/2" UNC	36.0	42.0	102	1/2" UNC	120	58-100	72
CRT2120	20-34	20B-1	13	101.6	92	1/2" UNC	36.0	42.0	102	1/2" UNC	120	61-100	72
DUPLEX CHAIN													
CRT1206	8-18	06B-2	15	88.9	70	3/8" UNC	29.5	35.5	60	M10	75	45-58	63
CRT1208	8-18	08B-2	15	88.9	70	3/8" UNC	29.5	35.5	60	M10	75	49-56	63
CRT1210	8-18	10B-2	15	88.9	70	3/8" UNC	29.5	35.5	80	M10	95	50-75	63
CRT2212	20-34	12B-2	15	101.6	92	1/2" UNC	36.0	42.0	76	1/2" UNC	94	60-70	72
CRT2216	20-34	16B-2	13	101.6	92	1/2" UNC	36.0	42.0	102	1/2" UNC	120	75-86	72
TRIPLEX CHAIN													
CRT1306	8-18	06B-3	15	88.9	70	3/8" UNC	29.5	35.5	60	M10	75	50-53	63
CRT1308	8-18	08B-3	15	88.9	70	3/8" UNC	29.5	35.5	80	M10	95	56-59	63
CRT1310	8-18	10B-3	15	88.9	70	3/8" UNC	29.5	35.5	80	M10	95	59-66	63
CRT2312	20-34	12B-3	15	101.6	92	1/2" UNC	36.0	42.0	102	1/2" UNC	120	70-85	72

All dimensions in mm except where indicated.

Mounting Instructions

The tensioner should always be mounted on the non-driving strand of chain, near to the larger sprocket and in mesh with the outside of the chain. The tensioner arm should be located so that its operating direction is opposite to that of the fixing screw. A clearance hole for the fixing screw is required in the machine framework. The mating surface on which the boss is mounted should be smooth, level and parallel to the line of drive.

The tension pressure is set by slightly loosening the fixing screw, then rotating the hexagon nut and housing to apply suitable tension to the chain, and locking in position by tightening the fixing screw. Tension pressures can be infinitely varied over the torque range indicated in the table. The adjustment marks on the torque arm body can be used for quick setting.

Tel +44(0) 121 360 0155 Fax +44(0) 121 325 1079 Email sales@crossmorse.com

Linear Chain Tensioners



The Linear Chain Tensioners are based on the 'LT' Series Tensioner, with the aluminium mounting block replaced by a plastic chain guide.

Mounted on the unloaded strand of the chain in compressed condition, the tensioner takes out slack in the chain drive. As the chain wears, the tensioner extends under its spring to take-up the slackness in the drive. The chain guides are manufactured from UHMW Polyethylene, selected for its inherent self lubricating properties, and are available in two series.

The standard series utilises a large radius guide in arc form to provide a smooth chain transmission for quiet operation with minimised wear.

The compact series have smaller radii circular guides, with full 180° wrap possible. These are used where space is restricted, and for tail sprockets on light loaded conveyors. Tensioners are available for simplex, duplex and triplex drives, and are also suitable for extended pitch and rollerless (bush) chains.

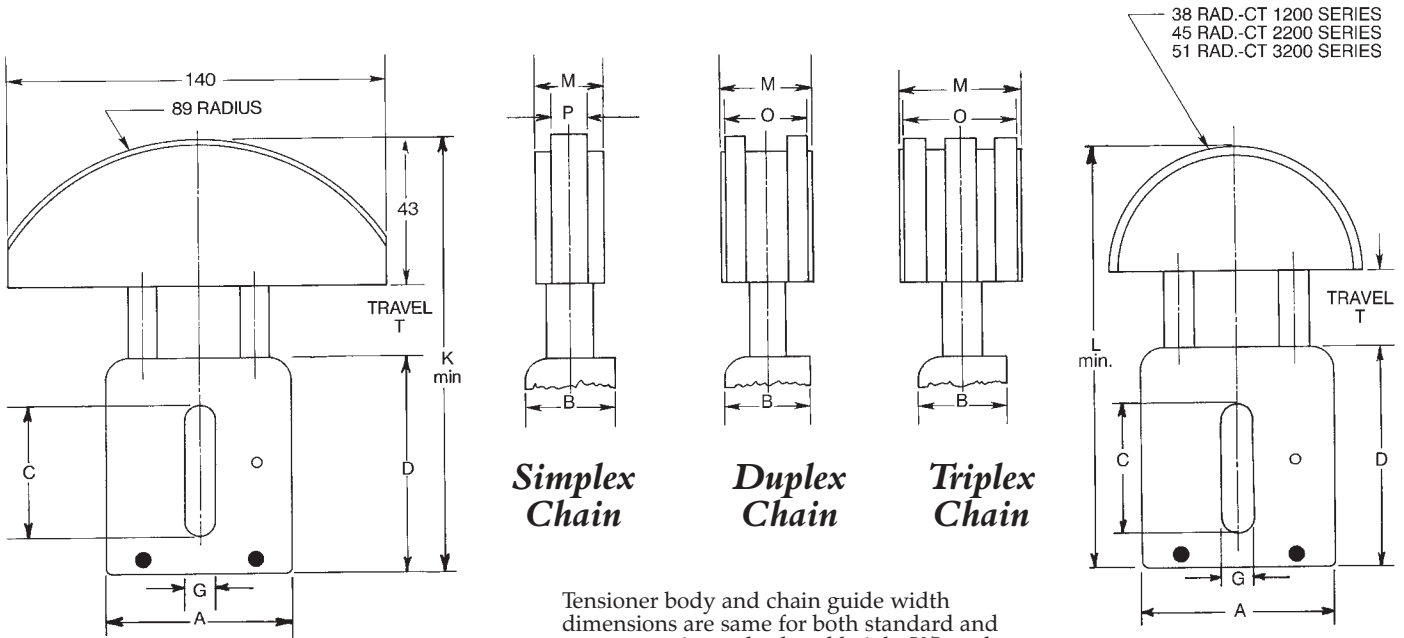

Standard Series

Compact Series

Tensioner body and chain guide width dimensions are same for both standard and compact series, only closed height K/L and guide radii differ.

Chain Size	Catalogue No.		Spring Force N	Dimensions - mm										
	Std. Series	Compact Series		A	B	C	D	G	K* min.	L* min.	M	O	P	T
SIMPLEX CHAINS														
06B-1	CLT 1101	CLT 1201	66-178	60	25	48	75	10.5	119	114	20	-	5.1	29
08B-1	CLT 1102	CLT 1202	66-178	60	25	48	75	10.5	119	114	20	-	7.1	29
10B-1	CLT 2101	CLT 2201	89-267	75	30	60	90	12.5	134	135	22	-	8.9	31
12B-1	CLT 2102	CLT 2202	89-267	75	30	60	90	12.5	134	135	22	-	10.7	31
16B-1	CLT 3101	CLT 3201	155-400	90	35	75	108	14.5	152	160	25	-	15.7	43
20B-1	CLT 3102	CLT 3202	155-400	90	35	75	108	14.5	152	160	25	-	18.0	43
DUPLEX CHAINS														
06B-2	CLT 1103	CLT 1203	66-178	60	25	48	75	10.5	119	114	20	15.3	-	29
08B-2	CLT 1104	CLT 1204	66-178	60	25	48	75	10.5	119	114	22	20.9	-	29
10B-2	CLT 2103	CLT 2203	89-267	75	30	60	90	12.5	134	135	25	25.0	-	31
12B-2	CLT 2104	CLT 2204	89-267	75	30	60	90	12.5	134	135	35	30.0	-	31
16B-2	CLT 3103	CLT 3203	155-400	90	35	75	108	14.5	152	160	45	44.5	-	43
TRIPLEX CHAINS														
06B-3	CLT 1105	CLT 1205	66-178	60	25	48	75	10.5	119	114	25	25.0	-	29
08B-3	CLT 1106	CLT 1206	66-178	60	25	48	75	10.5	119	114	35	34.8	-	29
10B-3	CLT 2105	CLT 2205	89-267	75	30	60	90	12.5	134	135	45	39.4	-	31

*Lmax = Lmin+T
Kmax = Kmin+T

Mounting Instructions

The tensioner should be positioned to operate on the outer side of the non-driving strand of chain. The surface to which the tensioner is clamped must be flat, smooth, and parallel to the line of drive. The tensioner is retained by a metric bolt with standard washer located at a minimum distance from chain centre line equal to $(K - 0.7D + 1)$ mm or $(L - 0.7D + 1)$ mm as applicable. On initial installation the bolt will be at the top of the slot providing automatic chain adjustment over travel distance T. If further movement is later required the unit can be advanced and reclamped with bolt lower in the slot.

Efson Fixed Chain Tensioners



The Efson Fixed Chain Tensioner uses the UHMW polyethylene circular guides from the compact linear tensioner, mounted in a rugged die cast aluminium frame which is slotted to enable quick adjustment in any direction using a single bolt.

This economical tensioner is ideal for applications where automatic tensioning is not required and for drives subject to frequent speed changes or torque reversals. It is possible to reverse drives with this tensioner providing speeds and chain loads are low.

The tensioner should always be mounted on the outside of the non driving chain strand close to the larger sprocket.

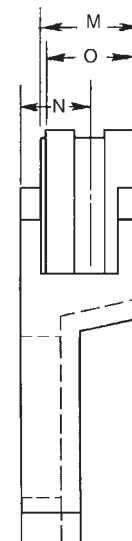
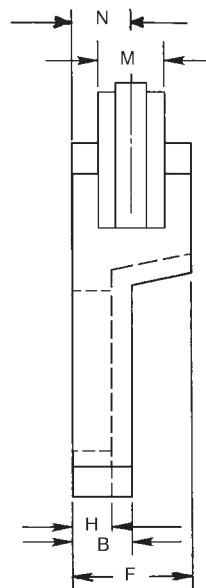
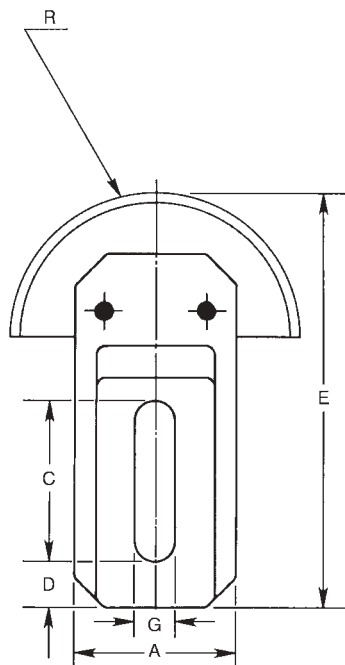

Simplex Chain

Duplex Chain

Catalogue No.	Chain Size	Dimensions in mm											
		A	B	C	D	E	F	G	H	M	N	O	R
CT1401	06B-1	40	15	73	10	141	30	10.5	10	20	15		38
CT1402	06B-2	40	15	73	10	141	30	10.5	10	20	15	15.3	38
CT1403	08B-1	40	15	73	10	141	30	10.5	10	20	15		38
CT2401	08B-2	50	18	85	12	157	36	13	12	22	18	20.9	38
CT2402	10B-1	50	18	85	12	164	36	13	12	22	18		45
CT2403	12B-1	50	18	85	12	164	36	13	12	22	18		45
CT3401	10B-2	60	20	82	13	164	40	13	14	25	20	25.0	45
CT3402	12B-2	60	20	82	13	164	40	13	14	35	25	30.0	45
CT3403	16B-1	60	20	82	13	169	40	13	14	25	20		51
CT3404*	16B-2	60	20	82	13	169	40	13	14	45	30	44.5	51
CT3405*	20B-1	60	20	82	13	169	40	13	14	25	20		51

*On these tensioner sizes additional clearance is required beyond tensioner mounting block to provide minimum chain path clearance.

Mounting Instructions

The tensioner should be positioned to operate on the outer side of the normally non-driving strand of chain. The surface to which the tensioner is clamped must be flat, smooth and parallel to the line of drive. The tensioner is retained by a single bolt with standard washer located at a minimum distance from chain centre line of 1/2E. Adjustment is made by positioning of bolt in slot plus turning tensioner up to 45 degrees from the perpendicular to chain centre line.

Tel +44(0) 121 360 0155

Fax +44(0) 121 325 1079

Email sales@crossmorse.com



Shady Lane, Great Barr,
Birmingham, England B44 9EU

Telephone: +44(0) 121 360 0155
Sales Direct: +44(0) 121 325 2500
Facsimilie: +44(0) 121 325 1079

Email: sales@crossmorse.com
Website: www.crossmorse.com

Power Transmission Solutions

Power Transmission Products

*Roller Chain Drives
Timing Belt Drives
Silent Chain Drives
Overload Clutches
Torque Limiters
Mounted Bearings
Stieber Freewheels
Shaft Couplings
Sprag Clutches
Tensioners
Sprockets
Pulleys
Gears*



Your Local Stockist:

