

M I N I

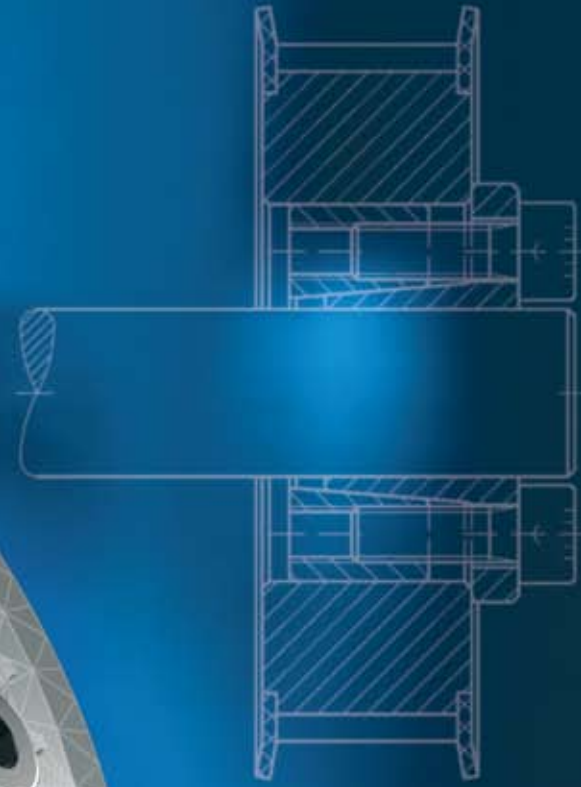

Locking Assemblies ■ Shrink Discs ■ Rigid Couplings



www.mav.it

our company

We are an Italian company world renowned for our creativity and ethics. Established in 1989 we have rapidly built a reputation for professional, reliable and comprehensive service and our extensive product range. We are located in Bosentino in Northern Italy, at the foot of the Dolomites, one of the most beautiful areas of the Alps.

our mission

Just as our products connect mechanical components in motion technology our purpose is to unite our partners with their goals, feelings, wishes - emotions. We aim to raise the standards in our industry in conjunction with customers and suppliers who share our goals of quality, safety and environmental conservation.

our vision

We see the market as a huge mosaic of which manufacturers, suppliers and customers are all part. Together we form a global partnership sharing common goals for our mutual benefit. In this mosaic we have a central position and wish to be a key point of reference.

Sandro Zamboni (MAV President)

**COMPANY
WITH QUALITY SYSTEM
CERTIFIED BY DNV
=ISO 9001/2000=**

Index

4	Shaft-Hub Connections: Traditional Methods
5	Shaft-Hub Connections: The MAV System
6-7	MAV 2061
8-9	MAV 5061
10-11	MAV 7903
12-13	MAV 1204
14-15	MAV 3008
16	Installation Instruction for Mini Locking Assemblies
17	Installation Instruction for Mini Rigid Couplings
18	Installation Instruction for Mini Shrink Discs
19	Technical Support

This catalogue contains complete information for the new MAV Mini Series line of Keyless Shaft-Hub Locking Devices. The following pages will help you to find the perfect solution for your application. Should you require assistance with an application, please feel free to contact MAV technical support. Our engineers will be pleased to provide any information you might need.

© 2005 MAV S.p.A. All rights reserved.

This catalogue may not be reproduced, either wholly or partly without the written authorisation of MAV S.p.A.
Information subject to change without prior notification.

Shaft-Hub Connections

Traditional Methods

Fig.1: shaft failure due to fatigue crack
(heat treated steel C45)

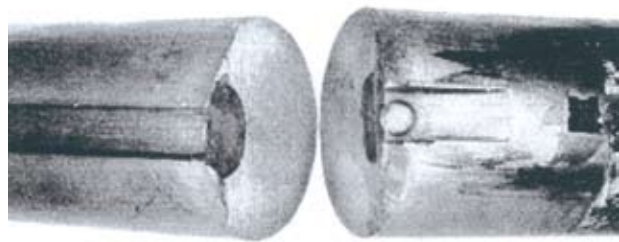

Keyway and splined locking systems show important disadvantages, in particular under overload and frequent torque reversal conditions. Connected parts undergo micro movements which cause them damage. The notch of keyway seat is a stress concentrator which reduces the fatigue strength. The figures show some fatigue failures fractographs of notched shafts (courtesy of ASM International, Metals Handbook, vol 9).

Keyways and splines are eliminated by forced fit systems (pressing, heating), where high radial pressures are generated due to shaft - hub interference. A backlash free coupling is obtained. In addition, sections of shafts and bearings can be reduced and, as a consequence, also costs. But this kind of connection shows difficulties during the mounting-dismantling steps.

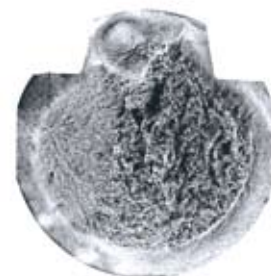

Fig.2: fatigue problem caused by torsion

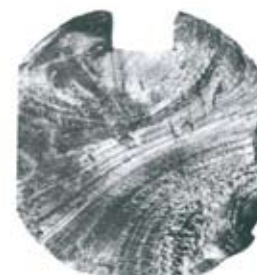

Fig.3: typical fatigue fracture

Shaft-Hub Connections

The MAV System

The MAV Locking Devices meet both the advantages of forced fit systems and simplified installation-removal. It is based on the wedge principle: the axial load of the screws generates through the tapers a high radial force that locks the parts by friction.

The main features of MAV Locking Devices are:

- shaft - locking device - hub tolerances are sufficient for easy mounting and correct positioning
- high manufacturing precision permits close geometrical tolerances, leading to a well balanced coupling, also for high speed conditions
- high pressures let high torque to be transmitted, also in addition with bending moment; fretting corrosion is eliminated
- absence of notches results in enhanced static and dynamical strength, leading to lighter and more cost-effective designs
- the large variety and the possibility of designing and manufacturing customized units let to find the best solution for any kind of specifications



The following are used throughout:

Mt: transmissible torque with $F_{ax}=0$ kN
Fax: transmissible axial load with $M_t=0$ Nm
Ps: contact pressure on shaft
Ph: contact pressure in hub bore

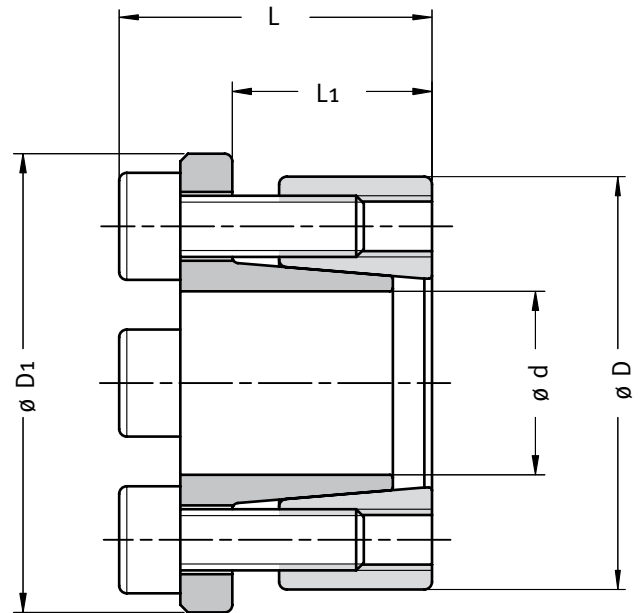

Example of order: MAV 2061 - 6 x 22 (d x D)

Features

- shaft - hub locking device with medium to high torque capacity
- single taper design, self-centering, self-locking
- general purpose unit, particularly recommended for servo- and stepping-motors
- no axial movement of hub during installation
- good bending moment capacity
- shaft tolerance h7-h11; hub bore tolerance H7-H11
- shaft and hub bore surface finish $Ra < 3,2 \mu m$

Application examples

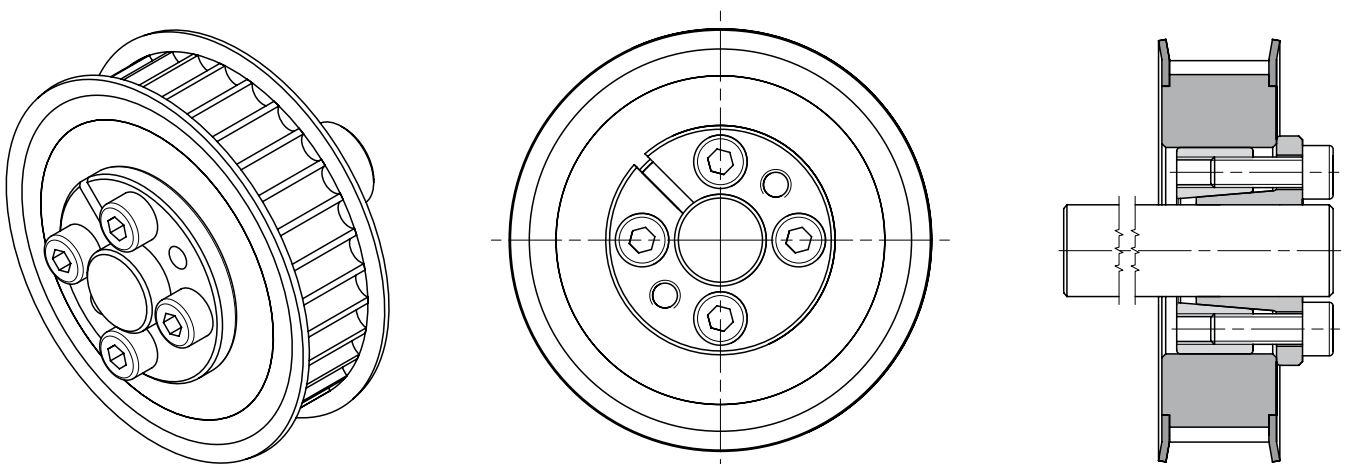
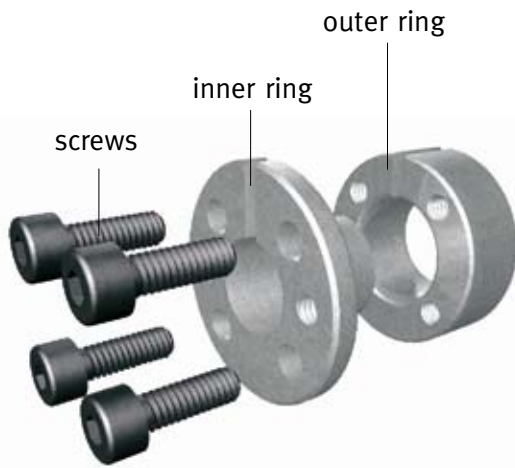

Fig.1: fastening of a drive pulley with MAV 2061

Composition

- slotted inner ring, with intergrated push-off threads
- slotted outer ring
- set of socket head cap screws, grade 12.9



Components of MAV 2061

DIMENSIONS						SCREWS					
d	x	D	D1	L	L1	size	Ma	Mt	Fax	Ps	Ph
mm		mm	mm	mm	mm		Nm	Nm	kN	N/mm ²	N/mm ²
6	x	22	25	20,5	13,1	M 4	5	22	7,3	323	88
7	x	22	25	20,5	13,1	M 4	5	26	7,3	277	88
8	x	22	25	20,5	13,1	M 4	5	29	7,3	242	88
9	x	25	28	20,5	13,1	M 4	5	33	7,3	215	77
10	x	25	28	20,5	13,1	M 4	5	37	7,3	194	77
11	x	27	30	20,5	13,1	M 4	5	54	9,7	235	96
12	x	27	30	20,5	13,1	M 4	5	58	9,7	215	96
14	x	30	33	24,5	15,1	M 4	5	102	14,6	231	108
15	x	30	33	24,5	15,1	M 4	5	110	14,6	215	108
16	x	30	33	24,5	15,1	M 4	5	117	14,6	202	108
17	x	34	37	24,5	15,1	M 4	5	124	14,6	190	95
18	x	34	37	24,5	15,1	M 4	5	131	14,6	179	95
19	x	34	37	24,5	15,1	M 4	5	139	14,6	170	95
20	x	40	45	30	19,2	M 5	10	235	23,5	207	104
22	x	40	45	30	19,2	M 5	10	258	23,5	189	104
24	x	43	48	30	19,2	M 5	10	375	31,3	230	129
25	x	43	48	30	19,2	M 5	10	391	31,3	221	129
28	x	50	55	33	21,2	M 5	10	547	39,1	218	122
30	x	50	55	33	21,2	M 5	10	586	39,1	203	122
32	x	55	60	33	21,2	M 5	10	625	39,1	191	111
35	x	55	60	33	21,2	M 5	10	684	39,1	174	111

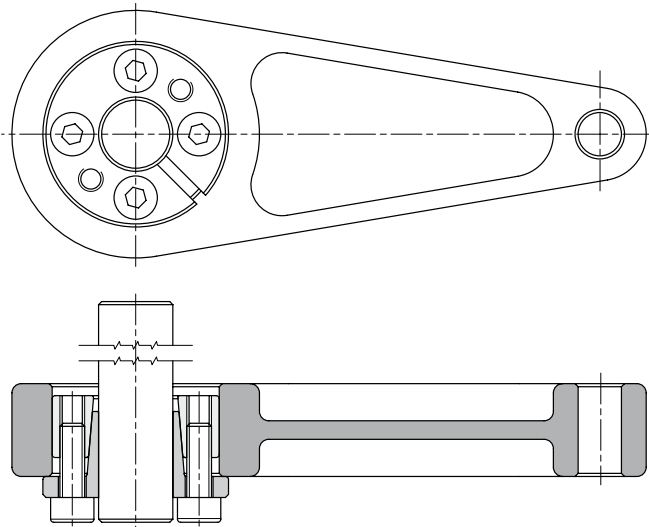

Fig.2: mounting a lever arm with MAV 2061

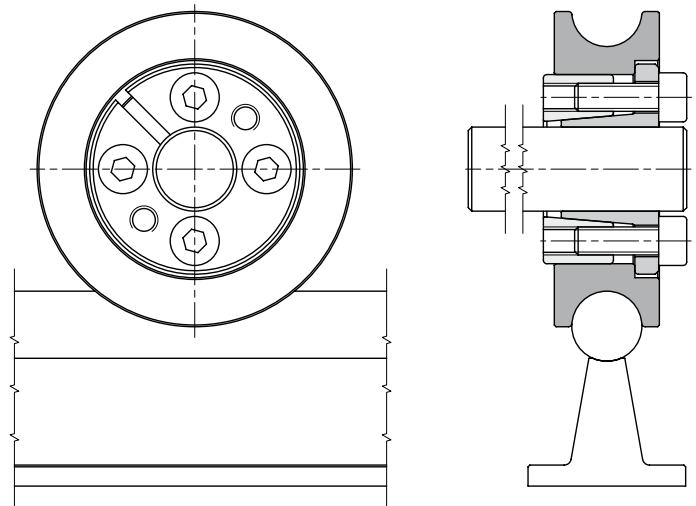
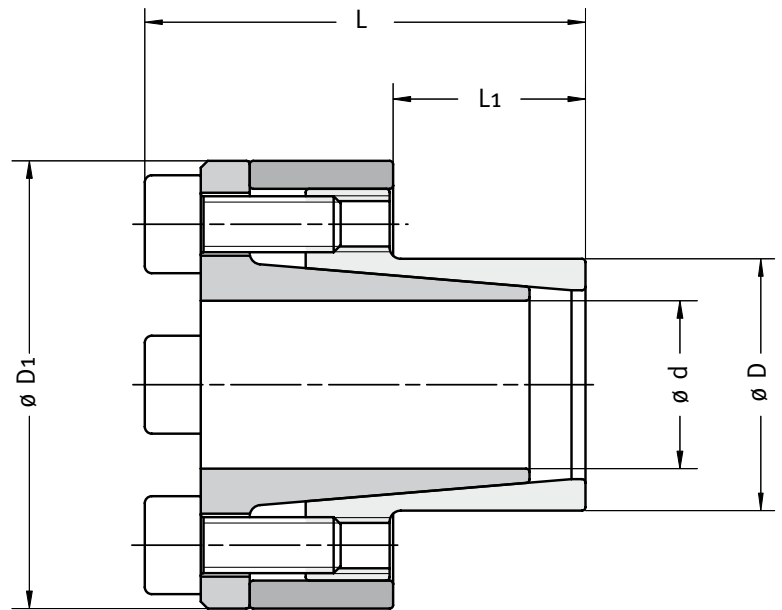

Fig.3: using MAV 2061 to connect a linear wheel



Features

- shaft - hub locking device with medium to high torque capacity
- single taper design, self-centering, self-locking
- designed for thin walled hubs
- no axial movement of hub during installation
- good bending moment capacity
- shaft tolerance h7-h11; hub bore tolerance H7-H11
- shaft and hub bore surface finish $Ra < 3,2 \mu m$

Example of order: MAV 5061 - 6 x 14 (d x D)

Application examples

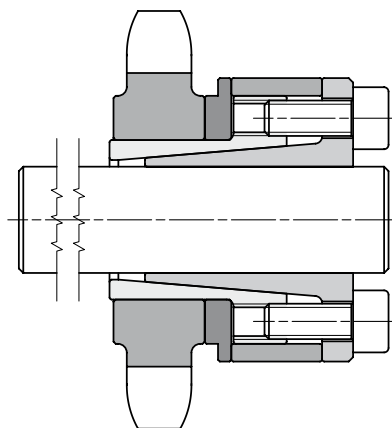
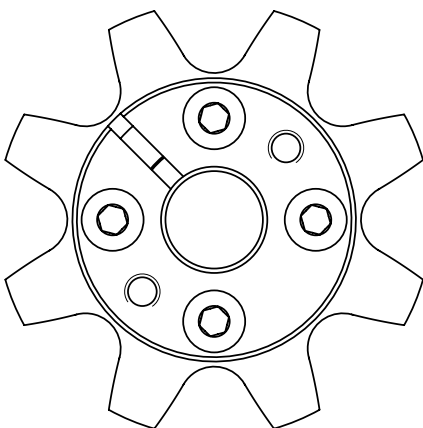

For applications with extremely thin hubs we can offer special Locking Assemblies designed according to your requirements.

Fig.: mounting a pinion with MAV 5061

Composition

- slotted inner ring, with intergrated push-off threads
- slotted outer ring
- spacer
- set of socket head cap screws, grade 12.9

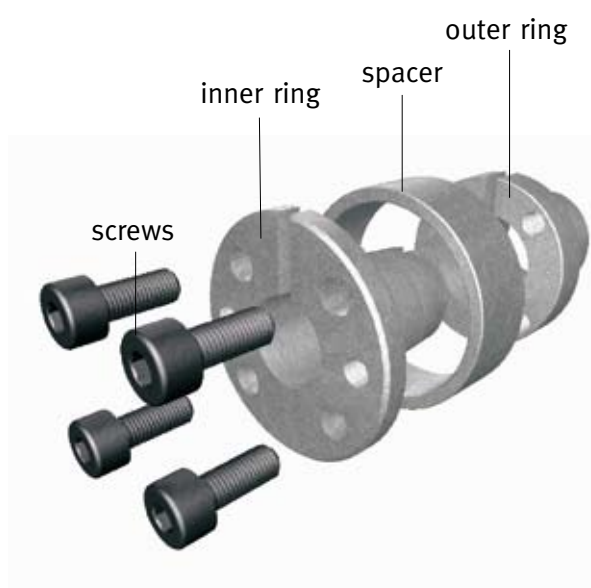

Components of MAV 5061

DIMENSIONS						SCREWS					
d mm	x	D mm	D1 mm	L mm	L1 mm	size	Ma Nm	Mt Nm	Fax kN	Ps N/mm ²	Ph N/mm ²
6	x	14	25	26	10	M 4	5	21	7	273	134
7	x	15	27	29	12	M 4	5	25	7	199	104
8	x	15	27	29	12	M 4	5	28	7	177	104
9	x	16	29	31	14	M 4	5	42	9	182	112
10	x	16	29	31	14	M 4	5	47	9	166	112
11	x	18	32	31,5	14	M 4	5	52	9	149	99
12	x	18	32	31,5	14	M 4	5	57	9	138	99
13	x	23	38	31,5	14	M 4	5	61	9	122	78
14	x	23	38	31,5	14	M 4	5	66	9	114	78
15	x	24	44	42,5	16	M 6	17	130	17	167	115
16	x	24	44	42,5	16	M 6	17	130	17	159	115
17	x	25	45	45,5	18	M 6	17	190	22	179	131
18	x	26	47	45,5	18	M 6	17	200	22	169	126
19	x	27	49	45,5	18	M 6	17	210	22	160	122
20	x	28	50	45,5	18	M 6	17	220	22	152	117

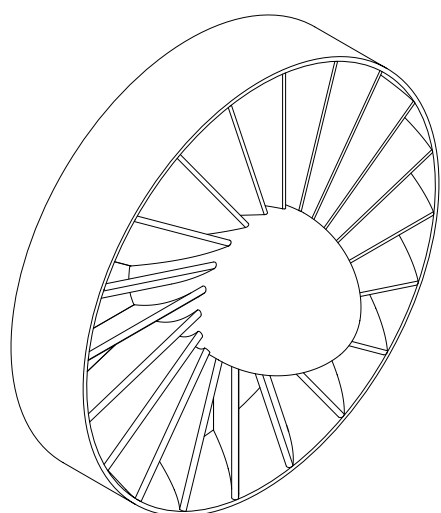

Since this fan blade is manufactured in plastic, the Locking Device MAV 5061 is the preferred solution, due to low contact pressures on shaft and hub.

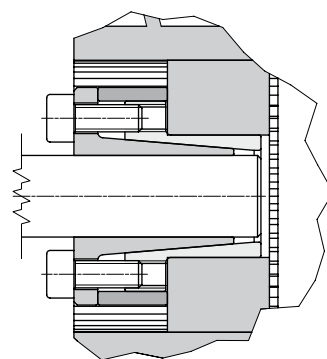
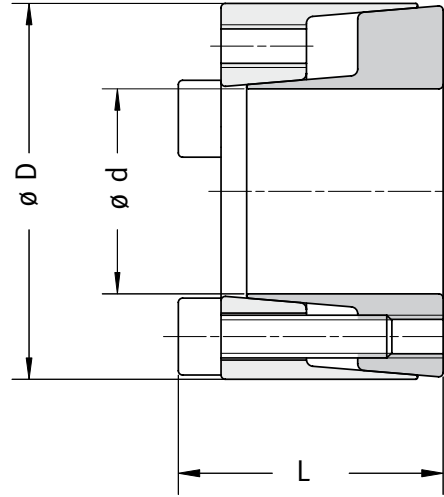

Fig.2: connecting fan blade with MAV 5061



Example of order: MAV 7903 - 6 x 16 (d x D)

Features

- medium to high torque capacity
- single taper design, self-centering, easy removal
- shaft tolerance h8-h11; hub bore tolerance H8-H11
- shaft and hub bore surface finish $R_a < 3,2 \mu\text{m}$

Application examples

Increasing / reducing torque capacity of MAV 7903

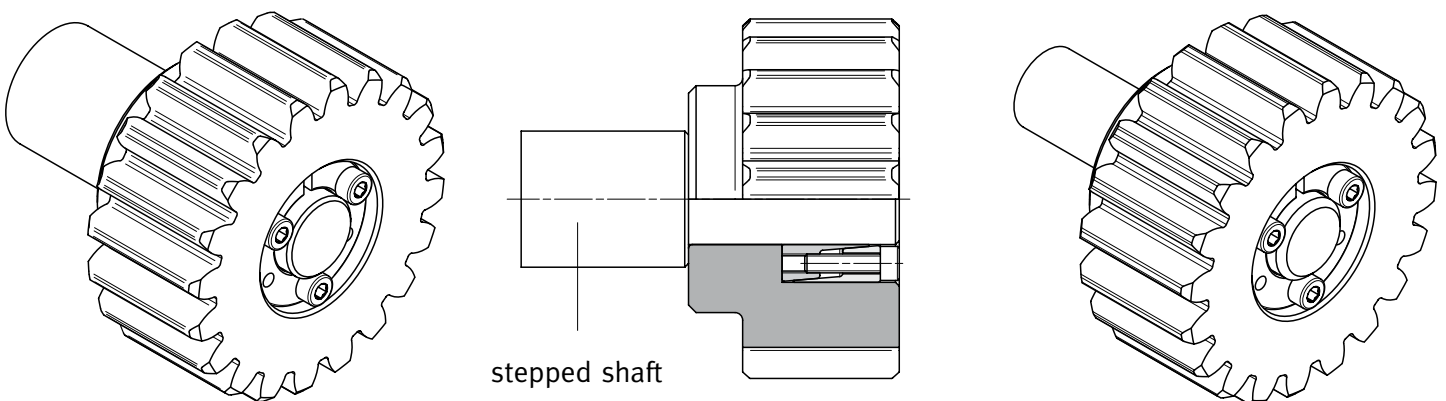
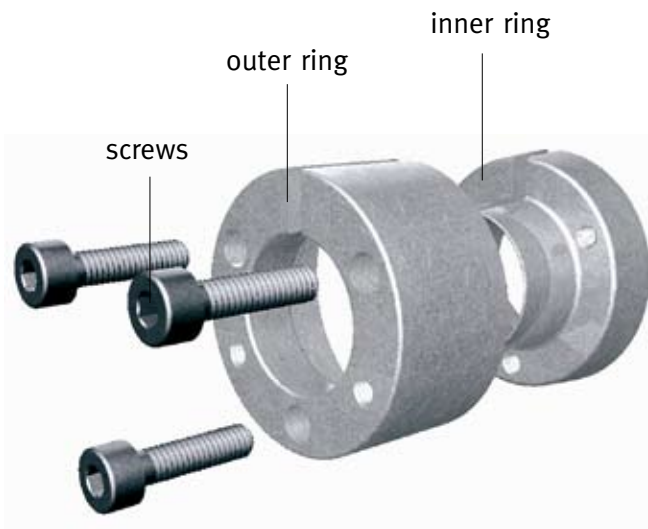

Fig.1: transmissible torque = $M_t \times 0,72$

Composition

- slotted outer ring, with intergrated push-off threads
- slotted inner ring
- set of socket head cap screws, grade 12.9



Components of MAV 7903

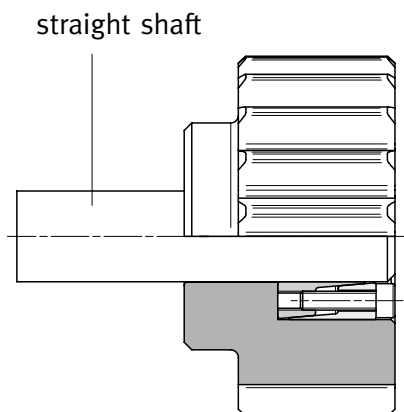
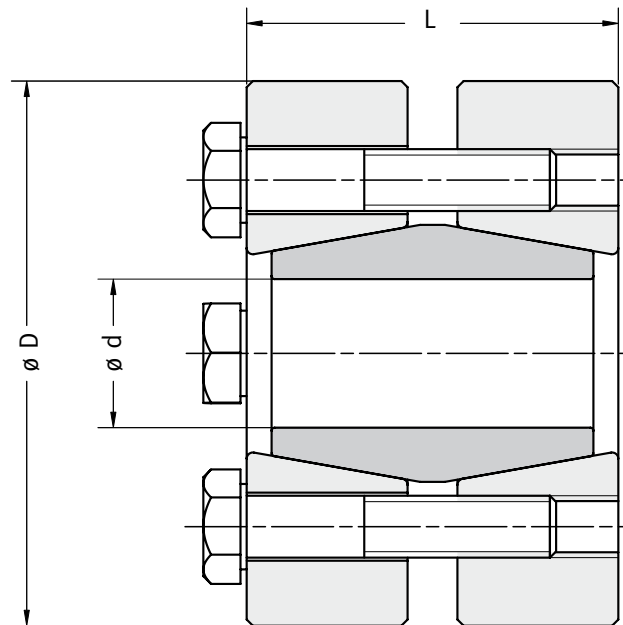

Fig.2: transmissible torque = $M_t \times 1$

DIMENSIONS					SCREWS					
d mm	x	D mm	L1 mm	L mm	size	Ma Nm	Mt Nm	Fax kN	Ps N/mm ²	Ph N/mm ²
5	x	16	11	13,5	M 2,5	1,2	5,5	2,9	197	62
6	x	16	11	13,5	M 2,5	1,2	8	2,9	164	62
6,35	x	16	11	13,5	M 2,5	1,2	9	2,9	155	62
7	x	17	11	13,5	M 2,5	1,2	10	2,9	141	58
8	x	18	11	13,5	M 2,5	1,2	11	2,9	123	55
9	x	20	13	15,5	M 2,5	1,2	17	3,9	130	58
9,53	x	20	13	15,5	M 2,5	1,2	18	3,9	123	58
10	x	20	13	15,5	M 2,5	1,2	19	3,9	117	58
11	x	22	13	15,5	M 2,5	1,2	21	3,9	106	53
12	x	22	13	15,5	M 2,5	1,2	23	3,9	97	53
14	x	26	17	20	M 3	2,2	42	6	95	51
15	x	28	17	20	M 3	2,2	45	6	89	48
16	x	32	17	21	M 4	5	83	10,4	145	72
17	x	35	21	25	M 4	5	88	10,4	117	57
18	x	35	21	25	M 4	5	94	10,4	110	57
19	x	35	21	25	M 4	5	99	10,4	104	57
20	x	38	21	26	M 5	10	170	17,1	162	85
22	x	40	21	26	M 5	10	180	17,1	147	81
24	x	47	26	32	M 6	17	290	24,2	149	76
25	x	47	26	32	M 6	17	300	24,2	143	76
25,4	x	47	26	32	M 6	17	300	24,2	141	76
28	x	50	26	32	M 6	17	500	36,3	192	107
30	x	55	26	32	M 6	17	540	36,3	179	97
32	x	55	26	32	M 6	17	580	36,3	168	97
35	x	60	31	37	M 6	17	840	48,5	167	97
38	x	65	31	37	M 6	17	920	48,5	154	90
40	x	65	31	37	M 6	17	970	48,5	146	90
42	x	75	36	44	M 8	41	1400	67	163	91
45	x	75	36	44	M 8	41	1500	67	152	91
48	x	80	36	44	M 8	41	2140	89,4	190	114
50	x	80	36	44	M 8	41	2230	89,4	182	114



Example of order: MAV 1204 - 6 x 35 (d x D)

Features

- shaft to shaft rigid coupling with high torque capacity and compact design
- connection of shafts with different diameters is possible, through inner ring modification or adapter sleeve
- shafts tolerance h7-h9
- shafts surface finish $R_a < 3,2 \mu\text{m}$

Application examples

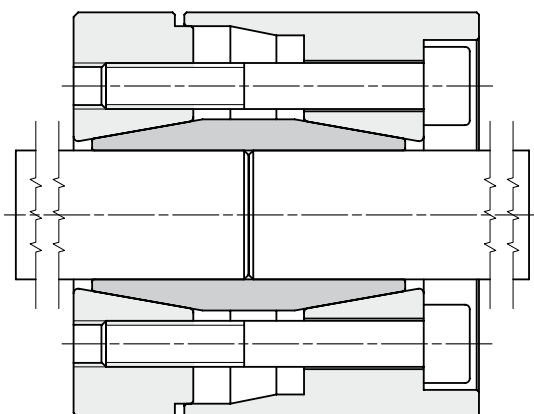
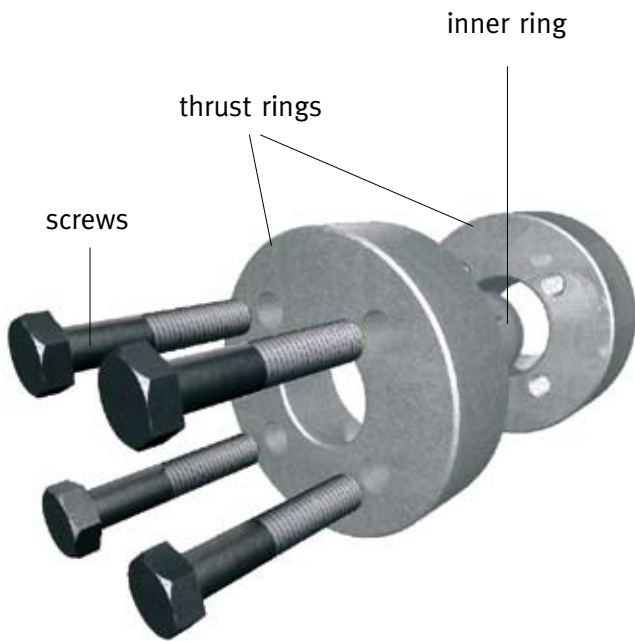

Fig.1: special MAV 1204
with cover for screws

Composition

- slotted inner ring
- two outer thrust rings
- set of hexagonal head cap screws, grade 10.9 (size M5 grade 8.8)



Components of MAV 1204

DIMENSIONS				SCREWS				
d	x	D	L	size	Ma	Mt	Fax	Ps
mm		mm	mm		Nm	Nm	kN	N/mm ²
6	x	35	19	M 5	4	27	9	491
7	x	35	19	M 5	4	31	9	421
8	x	35	19	M 5	4	36	9	368
9	x	39	23	M 5	4	50	11	327
10	x	39	23	M 5	4	55	11	294
11	x	39	23	M 5	4	61	11	268
12	x	44	30	M 5	4	80	13	226
13	x	44	30	M 5	4	87	13	209
14	x	44	30	M 5	4	93	13	194
15	x	52	34	M 6	12	160	22	275
16	x	52	34	M 6	12	170	22	258
17	x	52	34	M 6	12	180	22	242
18	x	52	34	M 6	12	200	22	229
19	x	52	34	M 6	12	210	22	217
20	x	60	40	M 6	12	360	36	301

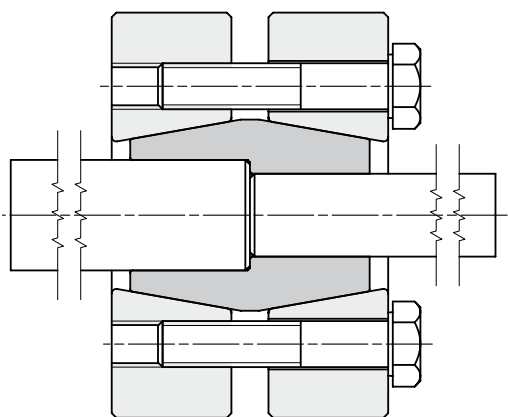

Fig.2: two different shaft sizes connected with special MAV 1204

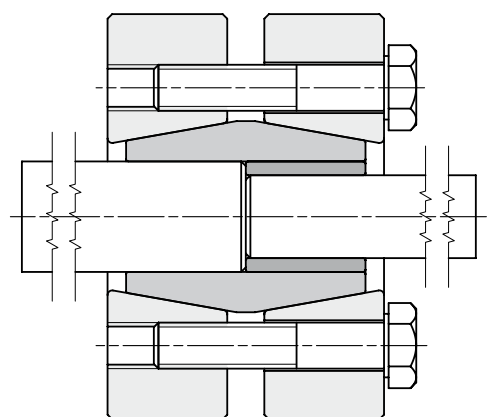
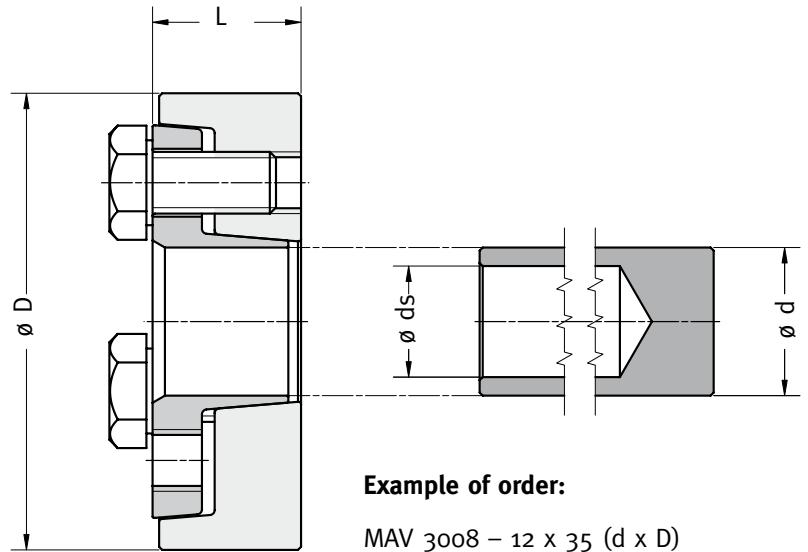

Fig.3: adapter sleeve system for MAV 1204



Example of order:

MAV 3008 – 12 x 35 (d x D)

Features

- two-part shrink disc for shaft - hollow shaft connection with high torque capacity
- single taper design
- medium bending moment capacity
- recommended for high speed applications
- shaft and hollow shaft surface finish $Ra < 3,2 \mu m$

Application examples

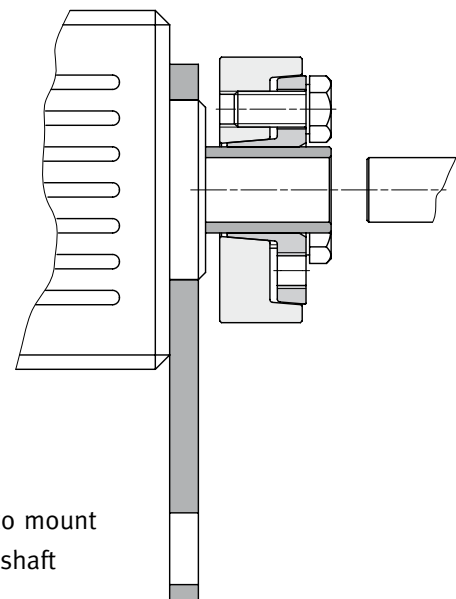
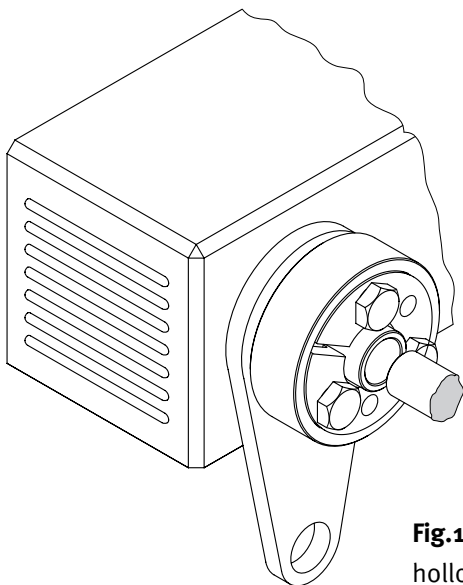
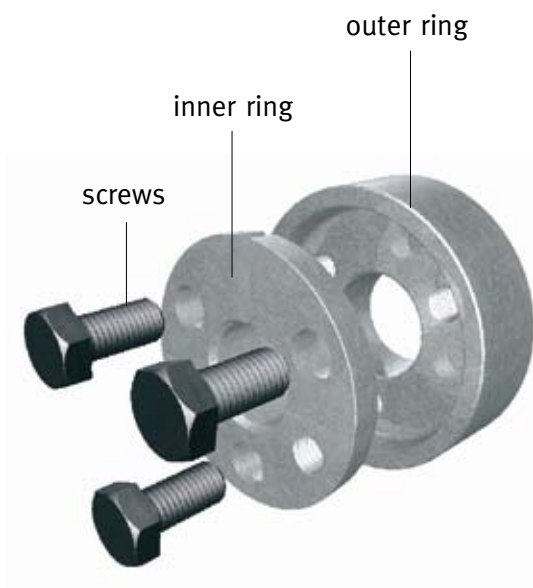

Fig.1: MAV shrink disc 3008 used to mount hollow shaft gearbox onto driven shaft

Composition

- slotted inner ring, with integrated push-off threads
- outer thrust ring
- set of hexagonal head cap screws, grade 10.9 (size M5 grade 8.8)



Components of MAV 3008

ds	ISO tolerance	gap max (mm)
6-10	H6-j6	0,011
11-18	H6-j6	0,014
19-30	H6-j6	0,017
31-50	H6-h6	0,032

Ps: contact pressure on shaft (diameter ds)

Ph: contact pressure on hollow shaft (diameter d)

d s mm	DIMENSIONS		SCREWS		Mt Nm	Fax kN	Ps N/mm ²	Ph N/mm ²
	d x D mm	L mm	size	Ma Nm				
9	12 x 35	11	M 5	5	21	4,6	122	301
10					40	7,9	188	301
11	14 x 38	11	M 5	5	29	5,3	114	258
12					51	8,4	167	258
13	16 x 41	15	M 6	12	96	14	200	308
14					132	18	239	308
15	18 x 44	15	M 6	12	121	16	190	274
16					159	19	220	274
17	20 x 47	15	M 6	12	146	17	179	247
18					186	20	203	247
19	24 x 50	18	M 6	12	172	18	145	235
20					218	21	165	235
21	24 x 50	18	M 6	12	267	25	184	235
24					297	24	137	205
25	30 x 60	20	M 6	12	352	28	150	205
26					412	31	162	205
28	36 x 72	22	M 8	30	563	40	169	234
30					714	47	187	234
31	36 x 72	22	M 8	30	722	46	177	234
34					734	43	135	215
35	44 x 80	24	M 8	30	831	47	144	215
36					933	51	153	215
38	50 x 90	26	M 8	30	1230	65	166	241
40					1490	74	180	241
42	50 x 90	26	M 8	30	1760	84	193	241

Installation Instructions

Mini Locking Assemblies

MAV Locking Assemblies are ready for installation. Performances are based on the following conditions:

- Locking Assembly, shaft and hub bore oiled
- oiled screws

Installation

1. If necessary clean and slightly oil the parts. Do not use MoS₂ based grease or similar to lubricate shaft, hub and Locking Assembly.
2. Disengage the rings by loosening the screws or, if necessary, by moving some of them into the push-off threads of the inner ring. Relocate any screws used to separate the rings.
3. Set torque wrench to the indicated tightening torque Ma. Tighten the screws in a crosswise pattern in several steps. For the last run, set the torque wrench 3-5% higher than the indicated tightening torque.
4. Reset torque wrench to the specified torque and make sure no screw can turn, otherwise repeat the procedure from step 3.

Removal

1. Sequentially loosen all screws and move the appropriate number into all push-off threads of the inner ring.
2. Tighten the screws in a crosswise pattern in several steps until rings disengage.

Before reinstalling of the unit, restore all the conditions as described above. Please contact MAV for any technical support you might require.

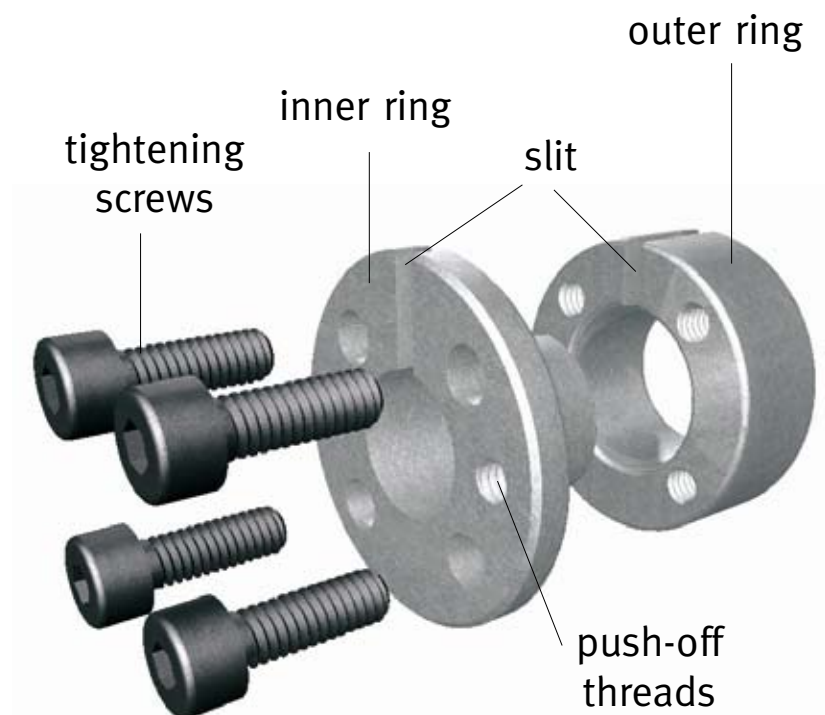

Components of MAV Locking Assembly

Installation Instructions

Mini Rigid Couplings

MAV Rigid Couplings are ready for installation. Performances are based on the following conditions:

- oiled shafts-coupling contact surfaces
- screws lubricated
- oiled tapers up to size 14 x 44
- lubricated tapers from size 15 x 52

Installation

1. Do not tighten the screws before mounting the unit.
2. The shafts tolerances must be similar.
3. Do not use MoS₂ based grease or similar to lubricate the shafts.
4. Mount the unit onto the shafts. Take care of shafts alignment and angular timing.
5. Set torque wrench to the indicated tightening torque Ma. Tighten the screws in a clockwise or counterclockwise pattern in several steps. For the last run, set the torque wrench 3-5% higher than the indicated tightening torque.
6. Reset torque wrench to the specified torque and make sure no screw can turn, otherwise repeat the procedure from step 5.

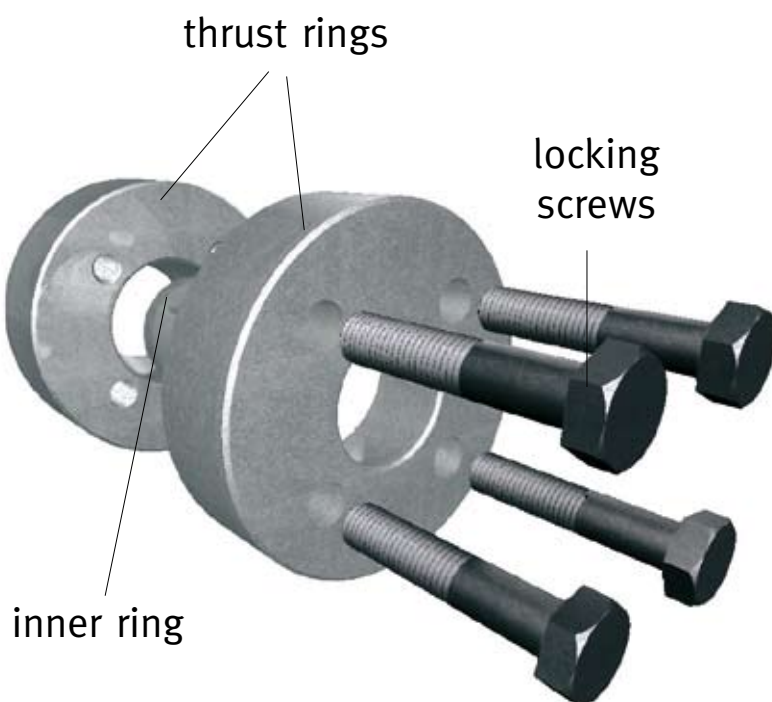

Components of MAV Rigid Coupling

Removal

1. Sequentially loosen (not remove) the screws in several steps. Due to self-releasing taper thrust rings will separate. If necessary help the disengagement by slightly hammering.

Before reinstalling of the unit, restore all the conditions as described above. Please contact MAV for any technical support you might require.

Installation Instructions

Mini Shrink Discs

MAV Shrink Discs are ready for installation. Performances are based on the following conditions:

- indicated maximum shaft-hub clearance
- shaft-hub dry contact
- screws lubricated
- oiled tapers

Installation

1. Clean and oil hub outer diameter and Shrink Disc bore prior to assembly. Do not tighten the screws.
2. Clean carefully shaft and hub bore and mount hub onto shaft.
3. Set torque wrench to the indicated tightening torque M_a . Tighten the screws in a clockwise or counterclockwise pattern in several steps. For the last run set the torque wrench 3-5% higher than the indicated tightening torque.
4. Reset torque wrench to the specified torque and make sure no screw can turn, otherwise repeat the procedure from step 3.

Removal

1. Remove dirt and rust from the hub before dismantling the Shrink Disc.
2. Sequentially loosen (not remove) the screws in several steps. Help the disengagement using the push-off threads.

Before reinstalling of the unit, restore all the conditions as described above. Please contact MAV for any technical support you might require.

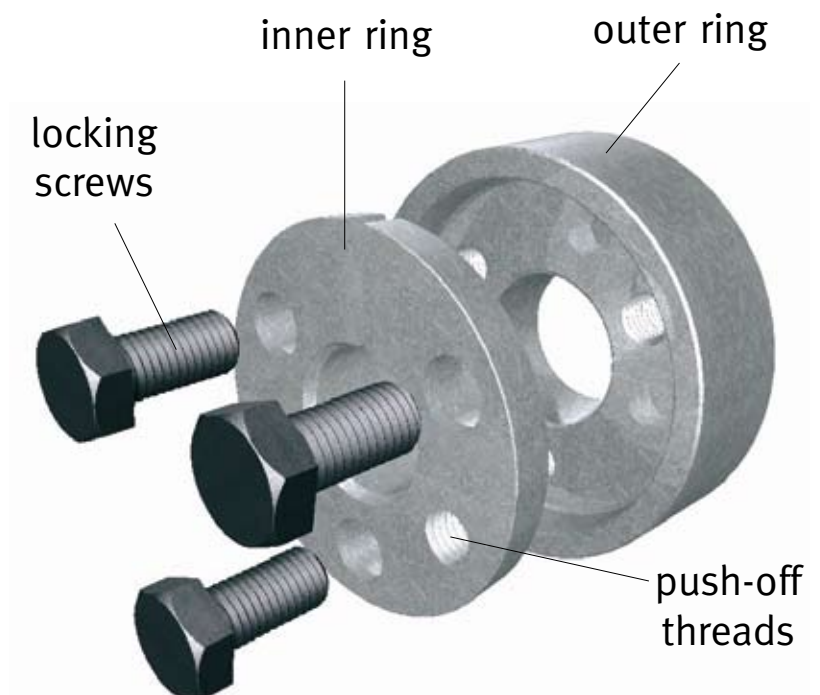

Components of MAV Shrink Disc

Technical Support

Data of application

If you need technical assistance to select the right MAV Locking Device for your application, please fill out this questionnaire and send it to us by fax using the following number:

+39 0461 84 51 50

Peak torque to be transmitted Mt _____ [Nm]
Peak axial force to be transmitted Fax _____ [kN]
Peak bending moment to be transmitted Mb _____ [Nm]
Peak radial force to be transmitted Fr _____ [kN]
Maximum speed n _____ [1/min]
Operating temperature To _____ [°C]
Ambient temperature Ta _____ [°C]

SHAFT DATA:

Size d _____ [mm]
If hollow-shaft; inner diameter di _____ [mm]
Material _____
Yield point Rp_{0,2} _____ [N/mm²]

HUB DATA:

Outer diameter dH _____ [mm]
Length L _____ [mm]
Material _____
Yield point Rp_{0,2} _____ [N/mm²]

Describe your application

(if possible, please attach a sketch or a drawing)



MAV S.p.A. ■ Via Venezia, 12 ■ 38049 Bosentino (TN) ■ Italy ■ Tel +39 0461 84 51 51 ■ Fax +39 0461 84 51 50 ■ www.mav.it ■ info@mav.it

Your local MAV distributor: