

DIMENSIONS					SCREWS		PERFORMANCES				WEIGHT
d mm	x	D mm	L1 mm	L mm	size	Ma Nm	Mt Nm	Fax kN	Ps MPa	Ph MPa	
18	x	47	42,0	48,0	M 6	17	510	57	322	123	0,4
19	x	47	42,0	48,0	M 6	17	540	57	305	123	0,4
20	x	47	42,0	48,0	M 6	17	570	57	290	123	0,4
22	x	47	42,0	48,0	M 6	17	620	57	263	123	0,3
24	x	50	43,0	49,0	M 6	17	680	57	241	116	0,4
25	x	50	43,0	49,0	M 6	17	710	57	232	116	0,4
28	x	55	43,0	49,0	M 6	17	790	57	207	105	0,5
30	x	55	43,0	49,0	M 6	17	850	57	193	105	0,5
32	x	60	43,0	49,0	M 6	17	1'200	76	241	129	0,5
35	x	60	43,0	49,0	M 6	17	1'300	76	221	129	0,5
38	x	65	43,0	49,0	M 6	17	1'400	76	203	119	0,6
40	x	65	43,0	49,0	M 6	17	1'500	76	193	119	0,5
42	x	75	50,5	58,5	M 8	41	2'200	100	221	124	1,0
45	x	75	50,5	58,5	M 8	41	2'400	100	206	124	0,9
48	x	80	50,5	58,5	M 8	41	2'500	100	193	116	1,0
50	x	80	50,5	58,5	M 8	41	2'600	100	185	116	1,0
55	x	85	50,5	58,5	M 8	41	3'800	140	225	145	1,0
60	x	90	50,5	58,5	M 8	41	4'200	140	206	137	1,1
63	x	95	50,5	58,5	M 8	41	4'400	140	196	130	1,2
65	x	95	50,5	58,5	M 8	41	45'00	140	190	130	1,2
70	x	110	60,0	70,0	M 10	83	7'000	200	190	121	2,2
75	x	115	60,0	70,0	M 10	83	7'500	200	178	116	2,4
80	x	120	60,0	70,0	M 10	83	8'000	200	167	111	2,5
85	x	125	60,0	70,0	M 10	83	98'00	230	179	122	2,7
90	x	130	60,0	70,0	M 10	83	10'300	230	169	117	2,8
95	x	135	60,0	70,0	M 10	83	13'600	290	200	141	2,9
100	x	145	71,0	83,0	M 12	145	15'000	300	173	119	4,2
110	x	155	71,0	83,0	M 12	145	16'500	300	157	112	4,1
120	x	165	71,0	83,0	M 12	145	20'600	340	165	120	4,9
130	x	180	71,0	83,0	M 12	145	27'900	430	190	137	5,9
140	x	190	82,0	86,0	M 14	230	32'300	460	171	126	7,2
150	x	200	82,0	86,0	M 14	230	43'200	580	200	150	7,5
160	x	210	82,0	86,0	M 14	230	46'100	580	187	143	8,0
170	x	225	82,0	86,0	M 14	230	58'800	690	212	160	9,4
180	x	235	82,0	86,0	M 14	230	62'300	690	200	153	9,8
190	x	250	82,0	86,0	M 14	230	82'100	860	237	180	11,2
200	x	260	82,0	86,0	M 14	230	86'500	860	225	173	13,9
220	x	285	98,0	102,0	M 16	355	104'000	950	178	138	17,2
240	x	305	98,0	102,0	M 16	355	142'000	1'200	204	161	18,3
260	x	325	98,0	102,0	M 16	355	185'000	1'400	227	181	21,0
280	x	355	121,0	127,0	M 20	690	207'000	1'500	187	148	32,0
300	x	375	121,0	127,0	M 20	690	259'000	1'700	204	163	34,0
320	x	405	140,0	148,0	M 20	690	355'000	2'200	205	162	48,0
340	x	425	140,0	148,0	M 20	690	441'000	2'600	225	180	51,0
360	x	455	164,0	174,0	M 24	1'200	518'000	2'900	193	152	72,0
380	x	475	164,0	174,0	M 24	1'200	615'000	3'200	205	164	75,0
400	x	495	164,0	174,0	M 24	1'200	647'000	3'200	195	158	79,0



Features

- Medium capacity
- Self-centering, self-locking
- Fixed axial hub position during tightening
(MAV 6902 only)
- Single taper design
- High contact length, low contact pressures
- Tolerances: shaft h8; hub bore H8
- Surface finish of shaft and hub bore $Ra < 3.2 \mu m$

Composition

- Slotted inner ring, with integrated push-off threads
- Slotted outer ring
- Spacer (MAV 6902 only)
- Set of socket head cap screws, grade 12.9

Code:

Ma: screws tightening torque

Mt: transmissible torque with Fax=0 kN

Fax: transmissible axial load with Mt=0 Nm

Ps: contact pressure on shaft

Ph: contact pressure in hub bore

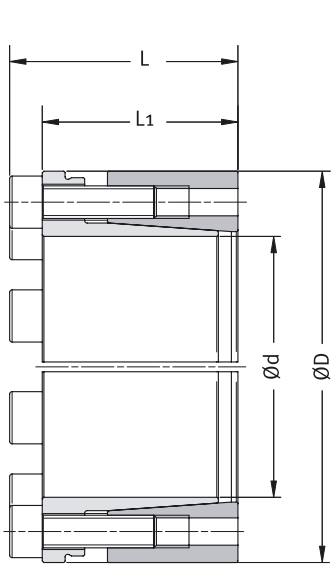

Example of order:
MAV 6901 50 x 80

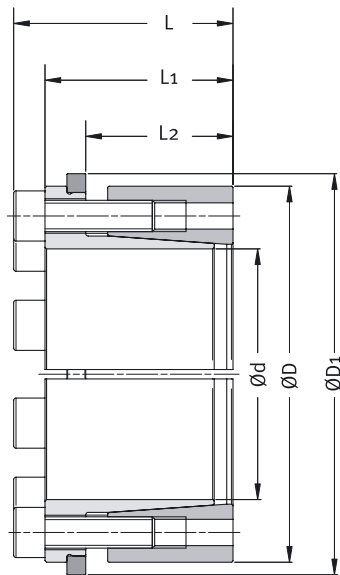

Example of order:
MAV 6902 50 x 80

Components

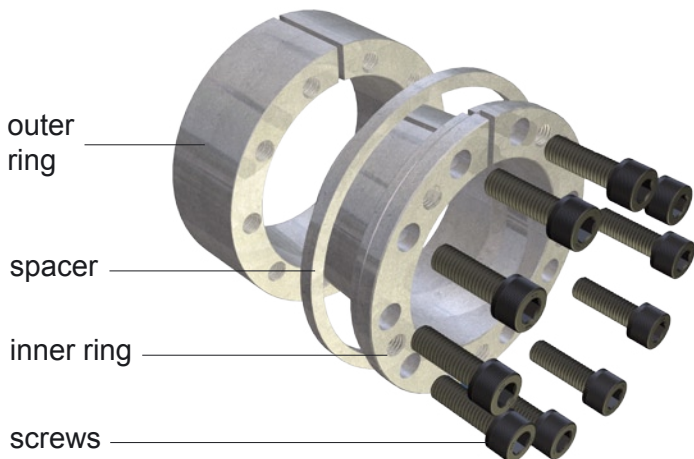

DIMENSIONS							SCREWS		PERFORMANCES				WEIGHT kg
d mm	x	D mm	D1 mm	L2 mm	L1 mm	L mm	size	Ma Nm	Mt Nm	Fax kN	Ps MPa	Ph MPa	
18	x	47	53	30,0	42,0	48,0	M 6	17	310	35	198	76	0,4
19	x	47	53	30,0	42,0	48,0	M 6	17	330	35	187	76	0,4
20	x	47	53	30,0	42,0	48,0	M 6	17	350	35	178	76	0,4
22	x	47	53	30,0	42,0	48,0	M 6	17	380	35	162	76	0,4
24	x	50	56	31,0	43,0	49,0	M 6	17	420	35	148	71	0,4
25	x	50	56	31,0	43,0	49,0	M 6	17	440	35	142	71	0,4
28	x	55	61	31,0	43,0	49,0	M 6	17	490	35	127	65	0,5
30	x	55	61	31,0	43,0	49,0	M 6	17	520	35	119	65	0,5
32	x	60	66	31,0	43,0	49,0	M 6	17	700	47	148	79	0,5
35	x	60	66	31,0	43,0	49,0	M 6	17	800	47	136	79	0,5
38	x	65	71	31,0	43,0	49,0	M 6	17	900	47	125	73	0,6
40	x	65	71	31,0	43,0	49,0	M 6	17	900	47	119	73	0,6
42	x	75	81	35,5	50,5	58,5	M 8	41	1'400	60	136	76	1,0
45	x	75	81	35,5	50,5	58,5	M 8	41	1'500	60	127	76	0,9
48	x	80	86	35,5	50,5	58,5	M 8	41	1'500	60	119	71	1,0
50	x	80	86	35,5	50,5	58,5	M 8	41	1'600	60	114	71	1,0
55	x	85	91	35,5	50,5	58,5	M 8	41	2'400	90	138	89	1,1
60	x	90	96	35,5	50,5	58,5	M 8	41	2'600	90	127	84	1,1
63	x	95	101	35,5	50,5	58,5	M 8	41	2'700	90	121	80	1,3
65	x	95	101	35,5	50,5	58,5	M 8	41	2'800	90	117	80	1,2
70	x	110	117	47,0	60,0	70,0	M 10	83	4'300	120	117	74	2,3
75	x	115	122	47,0	60,0	70,0	M 10	83	4'600	120	109	71	2,5
80	x	120	127	47,0	60,0	70,0	M 10	83	4'900	120	102	68	2,6
85	x	125	132	47,0	60,0	70,0	M 10	83	6'000	140	110	75	2,7
90	x	130	137	47,0	60,0	70,0	M 10	83	6'400	140	104	72	2,9
95	x	135	142	47,0	60,0	70,0	M 10	83	8'400	180	123	87	3,0
100	x	145	153	53,0	71,0	83,0	M 12	145	9'200	180	106	73	4,4
110	x	155	163	53,0	71,0	83,0	M 12	145	10'100	180	97	69	4,7
120	x	165	173	53,0	71,0	83,0	M 12	145	12'600	210	101	74	5,0
130	x	180	188	53,0	71,0	83,0	M 12	145	17'100	260	117	84	6,0
140	x	190	199	59,0	82,0	86,0	M 14	230	19'800	280	105	78	7,3
150	x	200	209	59,0	82,0	86,0	M 14	230	26'600	350	123	92	7,7
160	x	210	219	59,0	82,0	86,0	M 14	230	28'400	350	115	88	8,2
170	x	225	234	59,0	82,0	86,0	M 14	230	36'100	430	130	98	9,6
180	x	235	244	59,0	82,0	86,0	M 14	230	38'300	430	123	94	10,1
190	x	250	259	59,0	82,0	86,0	M 14	230	50'500	530	146	111	11,5
200	x	260	269	59,0	82,0	86,0	M 14	230	53'200	530	138	106	14,1
220	x	285	294	72,0	98,0	102,0	M 16	355	64'000	580	110	85	17,5
240	x	305	314	72,0	98,0	102,0	M 16	355	87'000	700	126	99	18,6
260	x	325	334	72,0	98,0	102,0	M 16	355	114'000	900	139	111	21,3
280	x	355	364	83,0	121,0	127,0	M 20	690	127'000	900	115	91	32,5
300	x	375	384	83,0	121,0	127,0	M 20	690	159'000	1'100	125	100	34,5
320	x	405	414	98,0	140,0	148,0	M 20	690	219'000	1'400	126	99	49,0
340	x	425	434	98,0	140,0	148,0	M 20	690	271'000	1'600	138	111	52,0
360	x	455	464	118,0	164,0	174,0	M 24	1'200	318'000	1'800	118	94	73,0
380	x	475	484	118,0	164,0	174,0	M 24	1'200	378'000	2'000	126	101	76,0
400	x	495	504	118,0	164,0	174,0	M 24	1'200	398'000	2'000	120	97	80,0