

Example of order: MAV 4061 50 x 80

Features

- High capacity
- Self-centering, self-locking
- Two thrust rings with single taper design
- Tolerances: shaft h8; hub bore H8
- Surface finish of shaft and hub bore $Ra < 3.2 \mu m$

Composition

- Slotted front thrust ring, with integrated push-off holes
- Slotted rear thrust ring
- Slotted outer ring, with integrated push-off threads
- Set of socket head cap screws, grade 12.9

Application examples

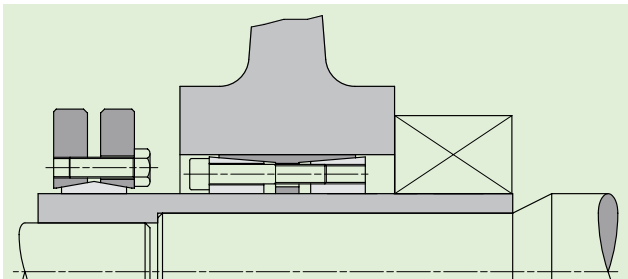

Simultaneous connection of two shafts with hollow shaft and hub with MAV 4061 and shrink disc MAV 2008

Components

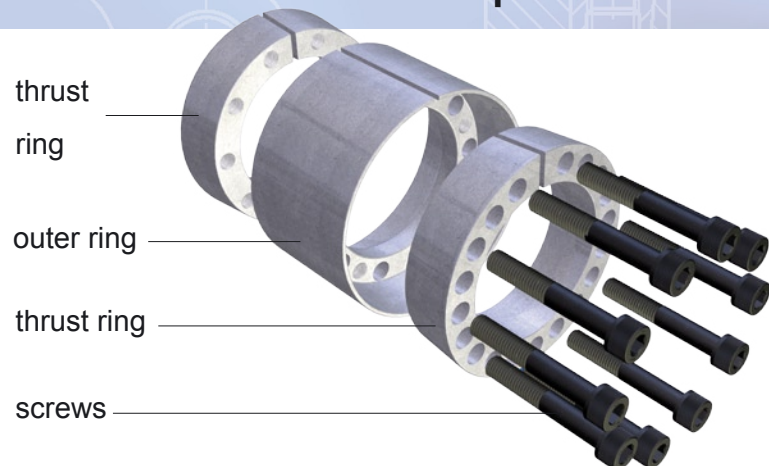

DIMENSIONS					SCREWS			PERFORMANCES				WEIGHT kg
d mm	x	D mm	L1 mm	L mm	size	Ma Nm	Mt Nm	Fax kN	Ps MPa	Ph MPa		
24	x	55	40	46	M 6	17	800	67	308	134	0,4	
25	x	55	40	46	M 6	17	840	67	295	134	0,4	
28	x	55	40	46	M 6	17	940	67	264	134	0,4	
30	x	55	40	46	M 6	17	1'000	67	246	134	0,4	
32	x	60	54	60	M 6	17	1'200	78	190	101	0,6	
35	x	60	54	60	M 6	17	1'400	78	174	101	0,6	
38	x	75	54	62	M 8	41	2'700	144	296	150	1,0	
40	x	75	54	62	M 8	41	2'900	144	281	150	1,0	
42	x	75	54	62	M 8	41	3'000	144	268	150	1,0	
45	x	75	54	62	M 8	41	3'200	144	250	150	0,9	
48	x	80	66	74	M 8	41	4'000	165	207	124	1,3	
50	x	80	66	74	M 8	41	4'100	165	198	124	1,2	
55	x	85	66	74	M 8	41	5'100	185	203	131	1,3	
60	x	90	66	74	M 8	41	6'200	206	207	138	1,4	
65	x	95	66	74	M 8	41	6'700	206	191	131	1,5	
70	x	110	80	90	M 10	83	11'800	338	229	145	2,8	
75	x	115	80	90	M 10	83	12'700	338	213	139	3,0	
80	x	120	80	90	M 10	83	14'900	372	220	147	3,1	
85	x	125	80	90	M 10	83	15'800	372	207	141	3,3	
90	x	130	80	90	M 10	83	18'200	405	213	148	3,5	
95	x	135	80	90	M 10	83	19'300	405	202	142	3,6	
100	x	145	102	114	M 12	145	27'700	555	210	145	5,6	
110	x	155	102	114	M 12	145	33'300	605	209	148	6,1	
120	x	165	102	114	M 12	145	42'400	706	223	162	6,5	
130	x	180	116	130	M 14	230	53'700	826	201	145	9,0	
140	x	190	116	130	M 14	230	67'400	963	217	160	9,5	
150	x	200	116	130	M 14	230	77'400	1'030	217	163	10,1	
160	x	210	116	130	M 14	230	88'100	1'100	217	166	10,6	
170	x	225	149	165	M 16	355	111'000	1'310	186	141	16,1	
180	x	235	149	165	M 16	355	126'000	1'410	188	144	16,9	
190	x	250	149	165	M 16	355	142'000	1'500	190	145	19,6	
200	x	260	149	165	M 16	355	150'000	1'500	181	139	20,5	
220	x	285	150	166	M 16	355	185'000	1'690	185	143	24,5	
240	x	305	150	166	M 16	355	225'000	1'870	188	148	26,5	
260	x	325	150	166	M 16	355	256'000	1'970	182	146	28,5	
280	x	355	177	197	M 20	690	370'000	2'640	190	150	42,5	
300	x	375	177	197	M 20	690	440'000	2'940	197	157	46,5	
320	x	405	177	197	M 20	690	493'000	3'080	194	153	56,0	
340	x	425	177	197	M 20	690	549'000	3'230	191	153	59,5	
360	x	455	203	225	M 22	930	680'000	3'780	183	145	80,0	
380	x	475	203	225	M 22	930	752'000	3'960	182	145	84,5	
400	x	495	203	225	M 22	930	864'000	4'320	188	152	88,0	
420	x	515	203	225	M 22	930	907'000	4'320	179	146	92,0	
440	x	535	203	225	M 22	930	950'000	4'320	171	141	96,0	
460	x	555	203	225	M 22	930	993'000	4'320	164	136	100,5	
480	x	575	203	225	M 22	930	1'209'000	5'040	183	153	103,0	
500	x	595	203	225	M 22	930	1'260'000	5'040	176	148	107,5	
520	x	615	203	225	M 22	930	1'404'000	5'400	181	153	111,0	
540	x	635	203	225	M 22	930	1'458'000	5'400	174	148	114,0	
560	x	655	203	225	M 22	930	1'613'000	5'760	179	153	118,5	
580	x	675	203	225	M 22	930	1'670'000	5'760	173	149	123,0	
600	x	695	203	225	M 22	930	1'782'000	5'940	173	149	128,0	

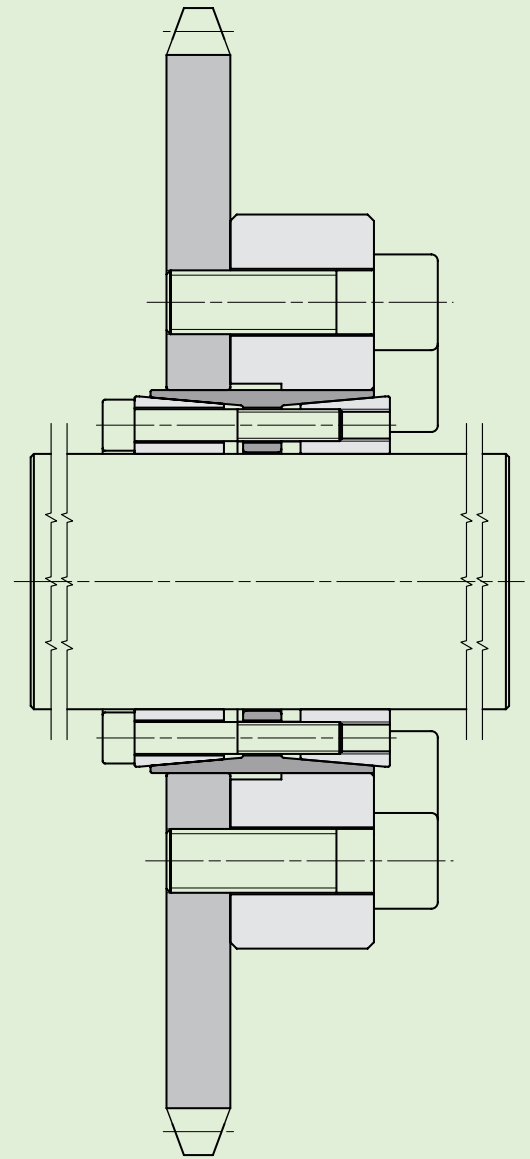

Pinion gear connected with MAV 4061. The resisting ring is used to compensate the pressure generated by the locking assembly in the zone adjacent to the pinion gear.

Code:

- Ma: screws tightening torque
- Mt: transmissible torque with Fax=0 kN
- Fax: transmissible axial load with Mt=0 Nm
- Ps: contact pressure on shaft
- Ph: contact pressure in hub bore