

MAV 1261

Standard Series

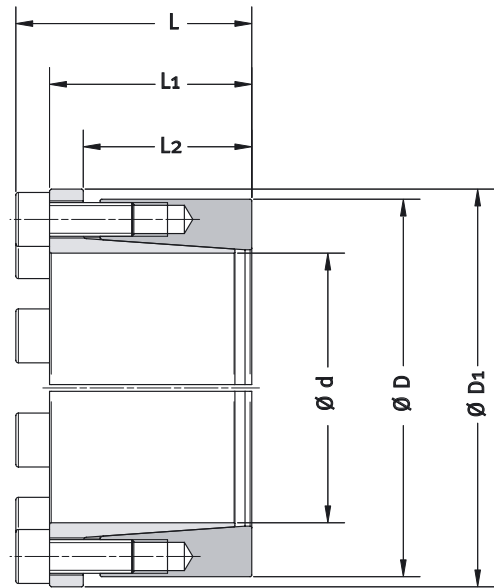

Example of order: MAV 1261 40 x 67

Features

- Medium capacity
- Self-centering, self-locking
- Fixed axial hub position during tightening
- Single taper design
- Zinc plated rings
- **LUBRICATION:** Rings, shaft and hub bore **OIL-FREE** and **DRY**.
Screws **OILED**
- Tolerances: shaft ± 0.08 mm; hub bore ± 0.08 mm
- Surface finish of shaft and hub bore $Ra < 3.2 \mu m$

Composition

- Slotted inner ring, with integrated push-off threads
- Slotted outer ring
- Set of socket head cap screws, grade 12.9

Application examples

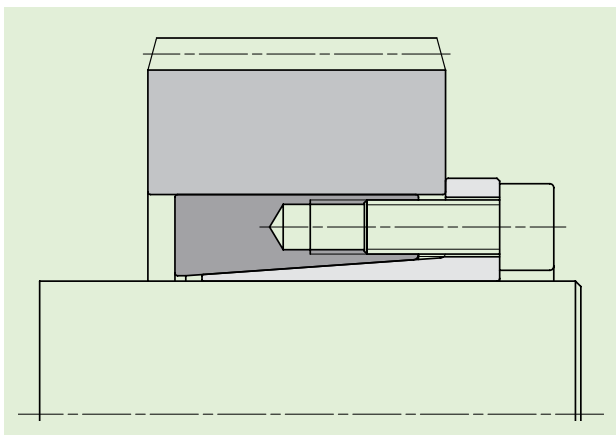

Gear connection

Components

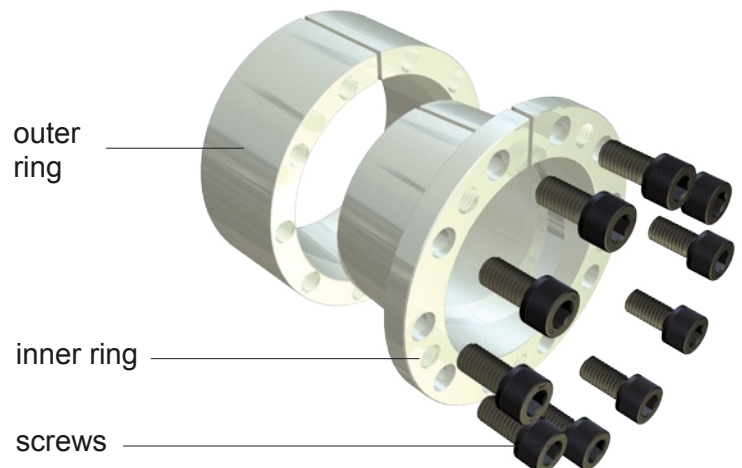

DIMENSIONS									SCREWS		PERFORMANCES					WEIGHT kg
d mm	d inch	x	D mm	D inch	D1 mm	L mm	L1 mm	L2 mm	size	Ma Nm	Mt Nm	Fax kN	ps MPa	ph MPa		
15,00		x	38,00		43	31,0	25,0	19,0	M 6 17	183	24,3	181	72	0,2		
15,88	5/8	x	38,10	1 1/2	43	31,0	25,0	19,0	M 6 17	193	24,3	171	71	0,2		
16,00		x	38,00		43	31,0	25,0	19,0	M 6 17	195	24,3	170	72	0,2		
17,00		x	38,00		43	31,0	25,0	19,0	M 6 17	207	24,3	160	72	0,2		
17,46	11/16	x	38,10	1 1/2	43	31,0	25,0	19,0	M 6 17	212	24,3	156	71	0,2		
18,00		x	38,00		43	31,0	25,0	19,0	M 6 17	219	24,3	151	72	0,2		
19,00		x	38,00		43	31,0	25,0	19,0	M 6 17	231	24,3	143	72	0,2		
19,05	3/4	x	38,10	1 1/2	43	31,0	25,0	19,0	M 6 17	232	24,3	143	71	0,2		
20,00		x	45,00		50	34,2	28,2	22,2	M 6 17	304	30,4	145	65	0,3		
20,64	13/16	x	44,45	1 3/4	50	34,2	28,2	22,2	M 6 17	314	30,4	141	65	0,3		
22,00		x	45,00		50	34,2	28,2	22,2	M 6 17	335	30,4	132	65	0,2		
22,23	7/8	x	44,45	1 3/4	50	34,2	28,2	22,2	M 6 17	338	30,4	131	65	0,2		
23,81	15/16	x	44,45	1 3/4	50	34,2	28,2	22,2	M 6 17	362	30,4	122	65	0,2		
24,00		x	45,00		50	34,2	28,2	22,2	M 6 17	365	30,4	121	65	0,2		
25,00		x	45,00		50	34,2	28,2	22,2	M 6 17	380	30,4	116	65	0,2		
25,40	1	x	44,45	1 3/4	50	34,2	28,2	22,2	M 6 17	386	30,4	114	65	0,2		
26,99	1 1/16	x	50,80	2	57	37,4	31,4	25,4	M 6 17	493	36,5	113	60	0,3		
28,00		x	51,00		57	37,4	31,4	25,4	M 6 17	511	36,5	109	60	0,3		
28,58	1 1/8	x	50,80	2	57	37,4	31,4	25,4	M 6 17	522	36,5	107	60	0,3		
30,00		x	51,00		57	37,4	31,4	25,4	M 6 17	548	36,5	102	60	0,3		
30,16	1 3/16	x	50,80	2	57	37,4	31,4	25,4	M 6 17	551	36,5	101	60	0,3		
31,75	1 1/4	x	50,80	2	57	37,4	31,4	25,4	M 6 17	580	36,5	96	60	0,3		
32,00		x	51,00		57	37,4	31,4	25,4	M 6 17	584	36,5	95	60	0,3		
33,34	1 5/16	x	60,33	2 3/8	67	50,0	44,0	38,0	M 6 17	811	48,7	82	45	0,6		
34,00		x	60,50		67	50,0	44,0	38,0	M 6 17	827	48,7	80	45	0,6		
34,93	1 3/8	x	60,33	2 3/8	67	50,0	44,0	38,0	M 6 17	850	48,7	78	45	0,6		
35,00		x	60,50		67	50,0	44,0	38,0	M 6 17	852	48,7	78	45	0,6		
36,00		x	60,50		67	50,0	44,0	38,0	M 6 17	876	48,7	76	45	0,6		
36,51	1 7/16	x	60,33	2 3/8	67	50,0	44,0	38,0	M 6 17	889	48,7	74	45	0,6		
38,00		x	60,50		67	50,0	44,0	38,0	M 6 17	925	48,7	72	45	0,5		
38,10	1 1/2	x	60,33	2 3/8	67	50,0	44,0	38,0	M 6 17	927	48,7	71	45	0,5		
39,69	1 9/16	x	66,68	2 5/8	73	54,8	48,8	42,8	M 6 17	966	48,7	61	36	0,8		
40,00		x	67,00		73	54,8	48,8	42,8	M 6 17	974	48,7	60	36	0,8		
41,28	1 5/8	x	66,68	2 5/8	73	54,8	48,8	42,8	M 6 17	1.005	48,7	58	36	0,8		
42,00		x	67,00		73	54,8	48,8	42,8	M 6 17	1.022	48,7	57	36	0,7		
42,86	1 11/16	x	66,68	2 5/8	73	54,8	48,8	42,8	M 6 17	1.043	48,7	56	36	0,7		
44,45	1 3/4	x	66,68	2 5/8	73	54,8	48,8	42,8	M 6 17	1.082	48,7	54	36	0,7		
45,00		x	73,00		81	62,8	56,8	50,8	M 6 17	1.095	48,7	45	28	1,0		
46,04	1 13/16	x	73,03	2 7/8	81	62,8	56,8	50,8	M 6 17	1.121	48,7	44	28	1,0		
47,63	1 7/8	x	73,03	2 7/8	81	62,8	56,8	50,8	M 6 17	1.159	48,7	43	28	1,0		
48,00		x	73,00		81	62,8	56,8	50,8	M 6 17	1.168	48,7	42	28	1,0		
49,21	1 15/16	x	73,03	2 7/8	81	62,8	56,8	50,8	M 6 17	1.198	48,7	41	28	0,9		
50,00		x	73,00		81	62,8	56,8	50,8	M 6 17	1.217	48,7	41	28	0,9		
50,80	2	x	73,03	2 7/8	81	62,8	56,8	50,8	M 6 17	1.236	48,7	40	28	0,9		

This series is used as an alternative to the hex nut keyless bushings. The force generated by large nut is provided by small quantity of screws, which eliminates the need of large and expensive wrenches and allows easier installation.

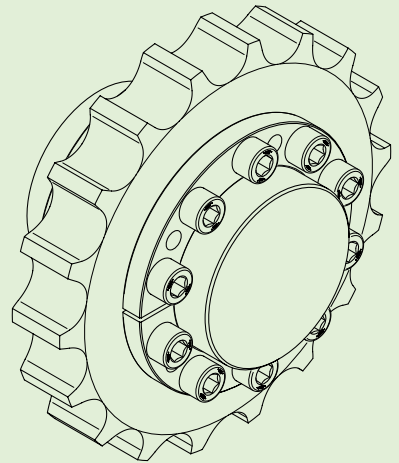

Pinion gear connection

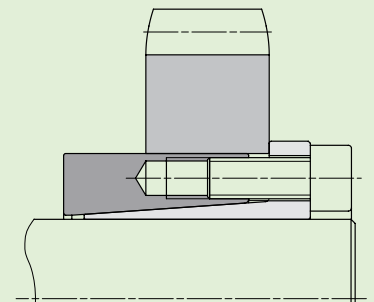

Pinion gear connection

Code:

Ma: screws tightening torque

Mt: transmissible torque with Fax=0 kN

Fax: transmissible axial load with Mt=0 Nm

Ps: contact pressure on shaft

Ph: contact pressure in hub bore