

MAV 1061

Standard Series

DIMENSIONS							SCREWS		PERFORMANCES				WEIGHT kg
d mm	x	D mm	D1 mm	L2 mm	L1 mm	L mm	size	Ma Nm	Mt Nm	Fax kN	Ps MPa	Ph MPa	
14	x	28	32,0	17,0	20,5	24,5	M 4	5	68	10	132	66	0,07
15	x	28	32,0	17,0	20,5	24,5	M 4	5	73	10	123	66	0,06
16	x	32	37,0	18,0	21,5	25,5	M 4	5	78	10	115	58	0,09
18	x	47	52,0	22,5	28,5	34,5	M 6	17	250	28	241	92	0,30
19	x	47	52,0	22,5	28,5	34,5	M 6	17	260	28	229	92	0,30
20	x	47	52,0	22,5	28,5	34,5	M 6	17	280	28	217	92	0,30
22	x	47	52,0	22,5	28,5	34,5	M 6	17	310	28	197	92	0,30
24	x	50	56,5	22,5	28,5	34,5	M 6	17	400	33	217	104	0,30
25	x	50	56,5	22,5	28,5	34,5	M 6	17	420	33	209	104	0,30
28	x	55	61,5	22,5	28,5	34,5	M 6	17	470	33	186	95	0,40
30	x	55	61,5	22,5	28,5	34,5	M 6	17	500	33	174	95	0,30
32	x	60	66,5	22,5	28,5	34,5	M 6	17	710	45	217	116	0,40
35	x	60	66,5	22,5	28,5	34,5	M 6	17	780	45	199	116	0,40
38	x	65	71,5	22,5	28,5	34,5	M 6	17	850	45	183	107	0,50
40	x	65	71,5	22,5	28,5	34,5	M 6	17	890	45	174	107	0,40
42	x	75	83,5	26,5	34,5	42,5	M 8	41	1'510	72	227	127	0,80
45	x	75	83,5	26,5	34,5	42,5	M 8	41	1'620	72	212	127	0,70
48	x	80	88,5	26,5	34,5	42,5	M 8	41	1'730	72	199	119	0,80
50	x	80	88,5	26,5	34,5	42,5	M 8	41	1'800	72	191	119	0,80
55	x	85	93,5	26,5	34,5	42,5	M 8	41	2'260	82	198	128	0,80
60	x	90	98,0	26,5	34,5	42,5	M 8	41	2'470	82	182	121	0,90
65	x	95	102,0	26,5	34,5	42,5	M 8	41	3'010	93	189	129	0,90
70	x	110	119,0	30,5	40,5	50,5	M 10	83	4'730	135	213	136	1,70
75	x	115	124,0	30,5	40,5	50,5	M 10	83	5'070	135	199	130	1,80
80	x	120	129,0	30,5	40,5	50,5	M 10	83	5'410	135	187	124	1,90
85	x	125	134,0	30,5	40,5	50,5	M 10	83	6'460	152	198	134	2,00
90	x	130	139,0	30,5	40,5	50,5	M 10	83	6'840	152	187	129	2,00
95	x	135	144,0	30,5	40,5	50,5	M 10	83	8'020	169	197	138	2,10
100	x	145	154,0	33,0	45,0	57,0	M 12	145	10'100	202	206	142	2,80
110	x	155	164,0	33,0	45,0	57,0	M 12	145	11'100	202	187	133	3,00
120	x	165	174,0	33,0	45,0	57,0	M 12	145	13'600	227	193	140	3,30
130	x	180	189,0	41,0	55,0	69,0	M 14	230	19'800	305	183	132	4,70
140	x	190	199,0	41,0	55,0	69,0	M 14	230	21'400	305	170	125	5,20
150	x	200	209,0	41,0	55,0	69,0	M 14	230	25'400	339	176	132	5,50
160	x	210	219,0	41,0	55,0	69,0	M 14	230	29'900	373	182	139	5,80
170	x	225	234,0	51,0	65,0	79,0	M 14	230	34'600	407	144	109	8,10
180	x	235	244,0	51,0	65,0	79,0	M 14	230	36'600	407	136	104	8,50
190	x	250	259,0	51,0	65,0	79,0	M 14	230	48'300	509	161	123	9,80
200	x	260	269,0	51,0	65,0	79,0	M 14	230	50'900	509	153	118	10,20
220	x	285	292,0	57,0	73,0	89,0	M 16	355	61'300	558	134	104	13,70
240	x	305	314,0	57,0	73,0	89,0	M 16	355	83'600	697	154	121	14,80
260	x	325	334,0	57,0	73,0	89,0	M 16	355	109'000	836	171	137	15,80
280	x	355	364,0	67,0	85,0	103,0	M 18	485	126'000	897	142	112	23,40
300	x	375	384,0	67,0	85,0	103,0	M 18	485	151'000	1'010	149	119	24,80
320	x	405	414,0	82,0	102,0	122,0	M 20	690	209'000	1'310	146	116	35,00
340	x	425	434,0	82,0	102,0	122,0	M 20	690	259'000	1'530	161	129	37,00
360	x	455	464,0	94,0	116,0	138,0	M 22	930	292'000	1'620	139	110	50,50
380	x	475	484,0	94,0	116,0	138,0	M 22	930	359'000	1'890	153	123	53,10
400	x	495	504,0	94,0	116,0	138,0	M 22	930	378'000	1'890	146	118	56,50

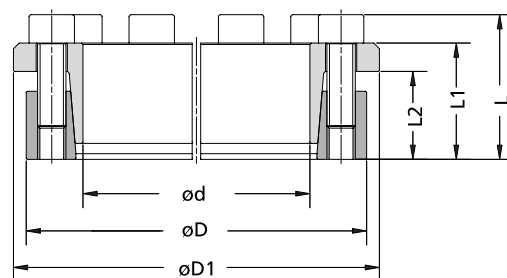

Example of order: MAV 1061 50 x 80

Features

- Medium capacity
- Self-centering, self-locking
- Fixed axial hub position during tightening (MAV 1061 only)
- Single taper design
- Tolerances: shaft h8; hub bore H8
- Surface finish of shaft and hub bore $Ra < 3.2 \mu m$

Application examples

Simultaneous connection of chain sprocket and conveyor pulley

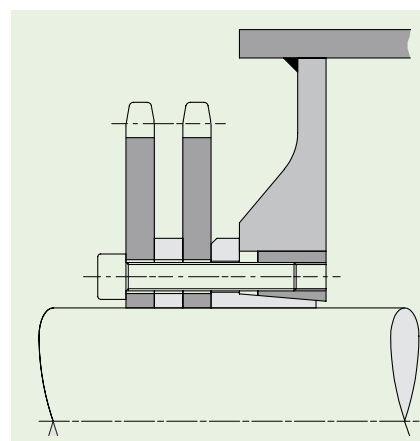

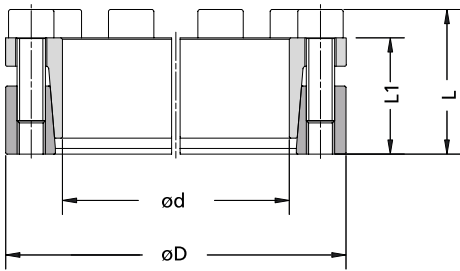

Example of order: MAV 1062 50 x 80



Composition

- Slotted inner ring, with integrated push-off threads
- Slotted outer ring
- Set of socket head cap screws, grade 12.9

Components

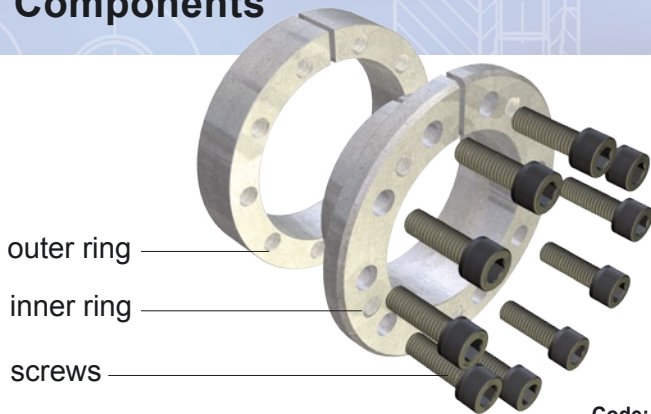

Code:

Ma: screws tightening torque
 Mt: transmissible torque with Fax=0 kN
 Fax: transmissible axial load with Mt=0 Nm
 Ps: contact pressure on shaft
 Ph: contact pressure in hub bore

DIMENSIONS					SCREWS		PERFORMANCES				WEIGHT kg
d mm	x	D mm	L1 mm	L mm	size	Ma Nm	Mt Nm	Fax kN	Ps MPa	Ph MPa	
14	x	32	21,5	25,5	M 4	5	108	15	209	91	0,09
15	x	32	21,5	25,5	M 4	5	116	15	195	91	0,09
16	x	32	21,5	25,5	M 4	5	123	15	183	91	0,08
18	x	47	28,5	34,5	M 6	14	330	36	314	120	0,30
19	x	47	28,5	34,5	M 6	14	340	36	297	120	0,30
20	x	47	28,5	34,5	M 6	14	360	36	283	120	0,30
22	x	47	28,5	34,5	M 6	14	400	36	257	120	0,20
24	x	50	28,5	34,5	M 6	14	520	43	283	136	0,30
25	x	50	28,5	34,5	M 6	14	540	43	271	136	0,30
28	x	55	28,5	34,5	M 6	14	610	43	242	123	0,30
30	x	55	28,5	34,5	M 6	14	650	43	226	123	0,30
32	x	60	28,5	34,5	M 6	14	930	58	283	151	0,40
35	x	60	28,5	34,5	M 6	14	1'010	58	258	151	0,30
38	x	65	28,5	34,5	M 6	14	1'100	58	238	139	0,40
40	x	65	28,5	34,5	M 6	14	1'160	58	226	139	0,40
42	x	75	34,5	42,5	M 8	35	2'040	97	307	172	0,70
45	x	75	34,5	42,5	M 8	35	2'190	97	287	172	0,60
48	x	80	34,5	42,5	M 8	35	2'340	97	269	161	0,70
50	x	80	34,5	42,5	M 8	35	2'430	97	258	161	0,70
55	x	85	34,5	42,5	M 8	35	3'060	111	268	174	0,80
60	x	90	34,5	42,5	M 8	35	3'340	111	246	164	0,80
65	x	95	34,5	42,5	M 8	35	4'070	125	255	175	0,90
70	x	110	40,5	50,5	M 10	69	6'230	178	281	179	1,60
75	x	115	40,5	50,5	M 10	69	6'680	178	262	171	1,60
80	x	120	40,5	50,5	M 10	69	7'120	178	246	164	1,70
85	x	125	40,5	50,5	M 10	69	8'510	200	261	177	1,80
90	x	130	40,5	50,5	M 10	69	9'020	200	246	170	1,90
95	x	135	40,5	50,5	M 10	69	10'570	223	259	182	2,00
100	x	145	45,0	57,0	M 12	120	13'200	265	270	186	2,60
110	x	155	45,0	57,0	M 12	120	14'600	265	245	174	2,90
120	x	165	45,0	57,0	M 12	120	17'900	298	253	184	3,10
130	x	180	55,0	69,0	M 14	190	26'000	400	240	173	4,50
140	x	190	55,0	69,0	M 14	190	28'000	400	223	164	5,00
150	x	200	55,0	69,0	M 14	190	33'300	444	231	173	5,20
160	x	210	55,0	69,0	M 14	190	39'100	488	238	181	5,60
170	x	225	65,0	79,0	M 14	190	45'300	533	189	143	7,70
180	x	235	65,0	79,0	M 14	190	48'000	533	178	137	8,10
190	x	250	65,0	79,0	M 14	190	63'300	666	211	161	9,30
200	x	260	65,0	79,0	M 14	190	66'600	666	201	154	9,90
220	x	285	73,0	89,0	M 16	295	81'000	736	178	137	13,30
240	x	305	73,0	89,0	M 16	295	110'000	920	203	160	14,20
260	x	325	73,0	89,0	M 16	295	144'000	1'104	225	180	15,30
280	x	355	85,0	103,0	M 18	405	166'000	1'187	187	148	22,70
300	x	375	85,0	103,0	M 18	405	200'000	1'340	197	157	24,30
320	x	405	102,0	122,0	M 20	580	279'000	1'750	196	155	34,10
340	x	425	102,0	122,0	M 20	580	346'000	2'040	215	172	36,00
360	x	455	116,0	138,0	M 22	780	388'000	2'160	185	146	49,40
380	x	475	116,0	138,0	M 22	780	478'000	2'520	204	163	51,90
400	x	495	116,0	138,0	M 22	780	503'000	2'520	194	157	55,30