

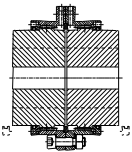





Standard models for general applications

	<p>Type S page 6 Nominal Torque: 1 200 up to 190 000 Nm Max bore : 50 up to 280 mm</p>			<p>Type S page 7 Nominal torque: 255 000 up to 4 950 000 Nm Max bore : 310 up to 800 mm</p>	
	<p>Type S PA page 8 Nominal torque: 1 200 up to 190 000 Nm Max bore : 50 up to 280 mm</p>			<p>Type S PA page 9 Nominal torque: 255 000 up to 4 950 000 Nm Max bore : 310 up to 800 mm</p>	
	<p>Type S E page 10 Nominal torque: 1 200 up to 190 000 Nm Max bore : 50 up to 280 mm</p>			<p>Type S E page 11 Nominal torque: 255 000 up to 4 950 000 Nm Max bore : 310 up to 800 mm</p>	
	<p>Type S DF page 12 Application for brake disc Nominal torque: 3 000 up to 43 000 Nm Max bore : 68 up to 170 mm</p>			<p>Type S DFC page 13 Application for brake disc elbow Nominal torque: 1 200 up to 190 000 Nm Max bore : 50 up to 280 mm</p>	
	<p>Type S BM page 14 Monobloc cover Nominal torque: 1 200 up to 190 000 Nm Max bore : 50 up to 280 mm</p>			<p>Type S BM page 15 Monobloc cover Nominal torque: 255 000 up to 4 950 000 Nm Max bore : 310 up to 800 mm</p>	
	<p>Type S JL page 16 Limited end float Nominal torque: 1 200 up to 190 000 Nm Max bore : 50 up to 280 mm</p>			<p>Type S ML-ML2 page 17 Long hub Nominal torque: 1 200 up to 138 000 Nm Max bore : 50 up to 250 mm</p>	
	<p>Type S V page 18 Vertical mounting Nominal torque: 1 200 up to 190 000 Nm Max bore : 50 up to 280 mm</p>			<p>Type S DB page 19 Clutch system Nominal torque: 1 200 up to 138 000 Nm Max bore : 50 up to 250 mm</p>	
	<p>Type S R page 20 Reinforced Coupling Nominal torque: 1 855 up to 302 450 Nm Max bore : 50 up to 280 mm</p>			<p>Type S R page 21 Reinforced Coupling Nominal torque: 400 000 up to 7 780 000 Nm Max bore : 310 up to 800 mm</p>	

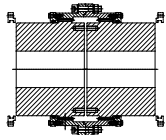
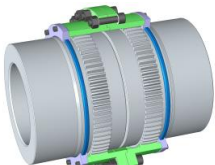
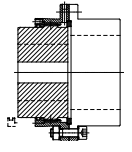
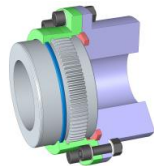
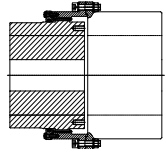
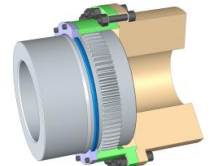
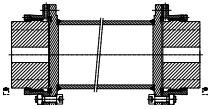
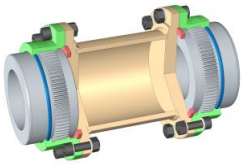
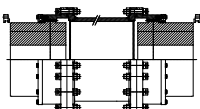
Type P-PA – Horizontal working position

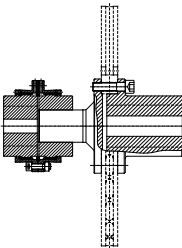
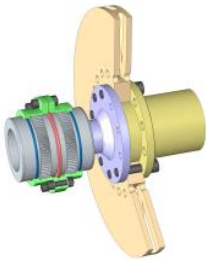
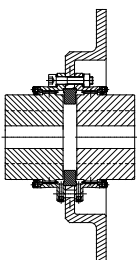
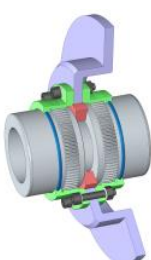
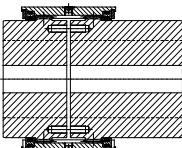
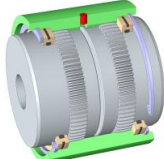
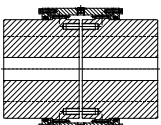
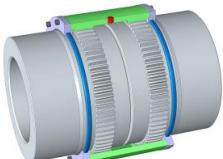
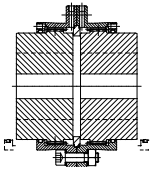
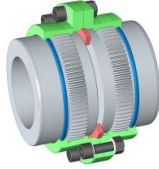
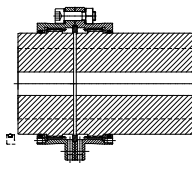
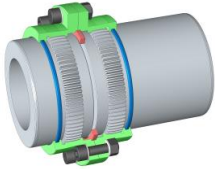
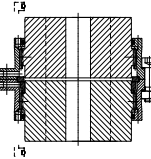
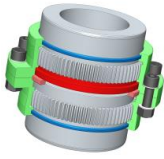
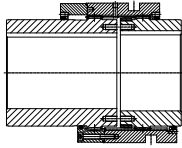
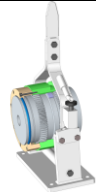
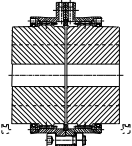

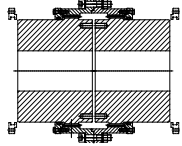
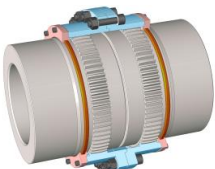
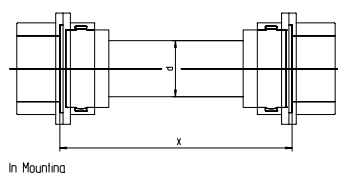
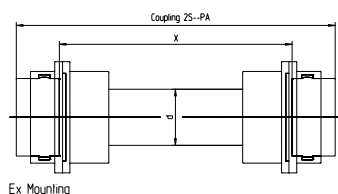
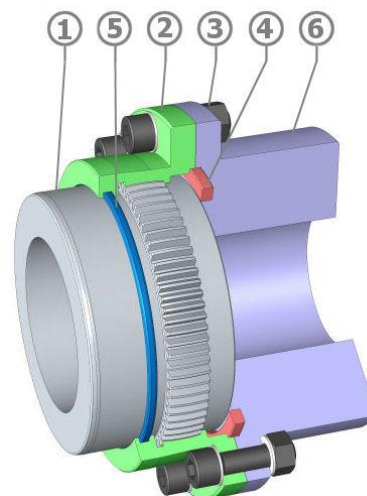
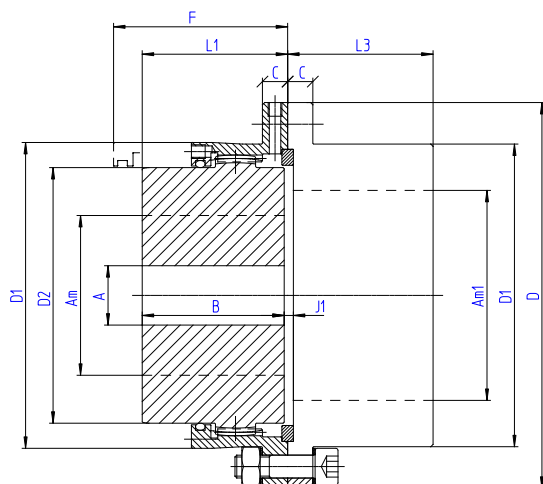
X: Distance between end shafts
X and d are defined according the needs

Item	Designation
1	Gear Hub
2	Half cover
3	Screws & Bolts
4	Centering ring supplied only if vertical or balanced execution
5	Seal
6	Solid hub

Example of designation **2 S 80 PA 1000 In SENIOR** size 80, composed with two half couplings **S80 P** with a shaft spacer whose length **X = 1000 In Mounting** (rigid hubs set up at the ends)
Ex Mounting (gear hubs set up at the ends)

Size		50	68	80	100	115	135	150	170	190	215	230	250	280
Nominal Torque	Nm	1200	3000	5200	9000	13700	21300	29200	43000	60700	88200	105000	138000	190000
Max Bore	Am*	50	68	80	100	115	135	150	170	190	215	230	250	280
	Am**	46	63	75	92	106	125	140	160	175	200	210	230	250
	Am1*	60	80	95	115	135	155	175	190	220	250	265	290	310
	Am1**	55	75	85	110	125	145	160	180	205	230	250	270	280
Rough bore	A	18	18	26	35	35	58	68	83	98	108	118	128	128
	B	43	50	62	76	90	105	120	135	150	175	190	220	310
	C	10	10	11	11	14	18	20	20	24	24	30	30	30
	D	105	140	169	200	228	266	298	330	368	410	440	473	498
	D1	83,6	112,6	134	164	188	219	245	277	309	351	374	407	432
	D2	69,4	95	112	138	159	188	209	238	263	302	319	349	374
	J1	3,5	4	4	5	6	7	8	9	10	10	11,5	12,5	12,5
	F	55	63	75	93	112	130	145	163	180	205	220	253	343
	L1	44,5	51,5	63,5	78,5	92,5	108	123	139	154	179	194	225	315
	L3	45	52,5	64,5	78,5	93,5	109	125	140	156	181	197,5	227,5	317,5
Weight •	Kg	4,5	9,1	15,6	27,6	43,5	70	99	139	193	281	352	472	712
Moment of Inertia J•	Kgm ²	0,005	0,017	0,041	0,106	0,220	0,484	0,861	1,493	2,6	4,74	6,85	10,6	17,16
Max speed (rpm)		5400	4000	3400	2700	2400	2000	1800	1600	1500	1300	1200	1100	1000
	y	14000	10500	8900	7200	6300	5400	4800	4200	3800	3300	3100	2900	2700
Weight of grease ▽	Kg	0,028	0,058	0,085	0,17	0,26	0,41	0,57	0,73	1,15	1,50	2,10	2,60	3

* Bore with keyway according ISO R 773 or DIN 6885/1 standards
 ** Shrink fitting
 • For couplings S..P - Solid hubs
 y Dynamically balanced
 ▽ Per coupling S..P

Type P-PA – Horizontal working position

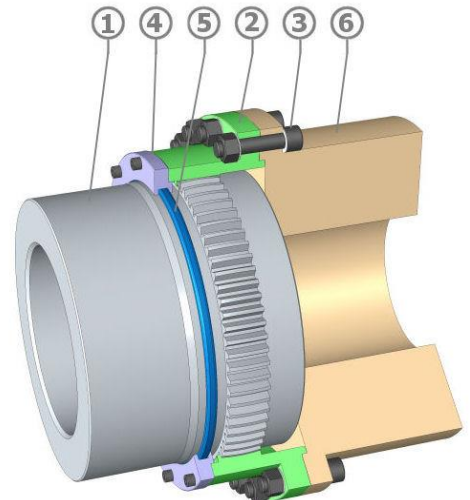
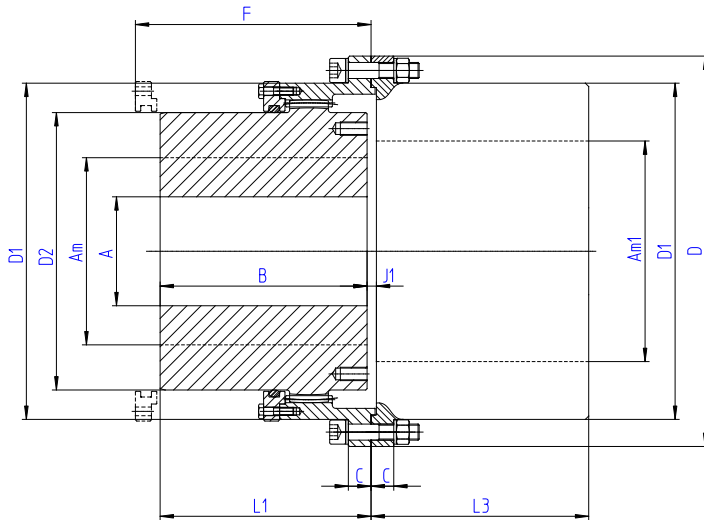

Item	Designation
1	Gear Hub
2	Half cover
3	Screws & Bolts
4	Cover
5	Seal
6	Solid hub

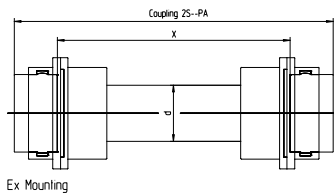

X: Distance between end shafts
X and d are defined according the needs

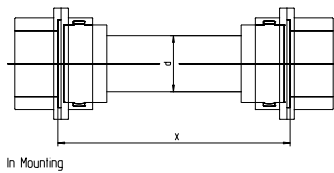

Inspection of the gear teeth is possible without having to remove the covers

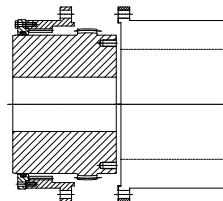

Example of designation **2 S 310 PA 1000 In SENIOR size 310**, composed with two half couplings **S310 P** with a 1000 mm shaft spacer.

In Mounting (rigid hubs set up at the ends)
Ex Mounting (gear hubs set up at the ends)

Size		310	330	370	400	430	475	510	550	610	650	710	750	800
Nominal Torque	Nm	255000	320000	410000	525000	670000	850000	1100000	1400000	1800000	2400000	3200000	3750000	4950000
Max Bore	Am*	310	330	370	400	430	475	510	550	610	650	710	750	800
	Am**	310	330	370	400	430	475	510	550	610	650	710	750	800
	Am1	Consult CMD												
Rough bore	A	163	176	191	240	257	279	304	329	358	394	434	457	501
	B	310	330	350	370	430	480	505	515	535	575	610	650	700
	C	34	34	39	43	47	56	56	55	65	70	70	70	75
	D	575	608	676	735	793	940	990	1100	1225	1285	1395	1450	1555
	D1	494	518	576	637	695	785	840	910	1000	1060	1170	1225	1295
	D2	411	438	492	535	581	645	700	770	835	890	975	1030	1095
	J1	16	16	16	20	20	20	24	28	30	30	32	32	32
	F	350	370	395	420	478	550	570	575	600	640	680	720	770
	L1	316	336	356	377.5	437.5	488	515	525	547.5	587.5	625	665	715
L3	320	340	360	382	442	492	519	531	552	592	628	668	718	
Weight •	Kg	891,5	1049	1381.1	1774,4	2428,7	3476.1	4223,5	5118.7	6442,7	7794,4	9954,4	11582,7	14105,5
Moment of Inertia J•	Kgm ²	26,46	34,5	56,4	88,2	141,6	265,4	367,7	530,6	819	1106.4	1693.7	2142,2	2947,8
Max speed (rpm)		903	857	760	696	643	573	542	495	446	418	377	358	341
	y	2409	2285	2026	1857	1714	1528	1445	1320	1188	1114	1005	955	909
Weight of grease ∇	Kg	3.1	3.31	3.95	5.5	6.75	9.1	11.15	11.9	15.25	18.55	24.25	31	36.75

* Bore with keyway according ISO R 773 or DIN 6885/1 standards
 ** Shrink fitting
 • For couplings S..P - Solid hubs
 y Dynamically balanced
 ∇ Per coupling S..P

Type SE – Horizontal working position

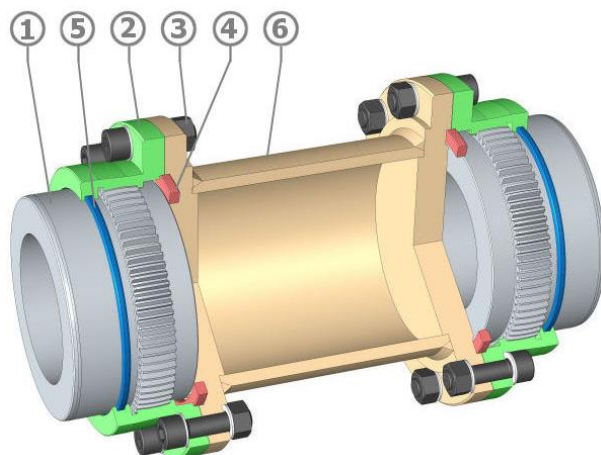
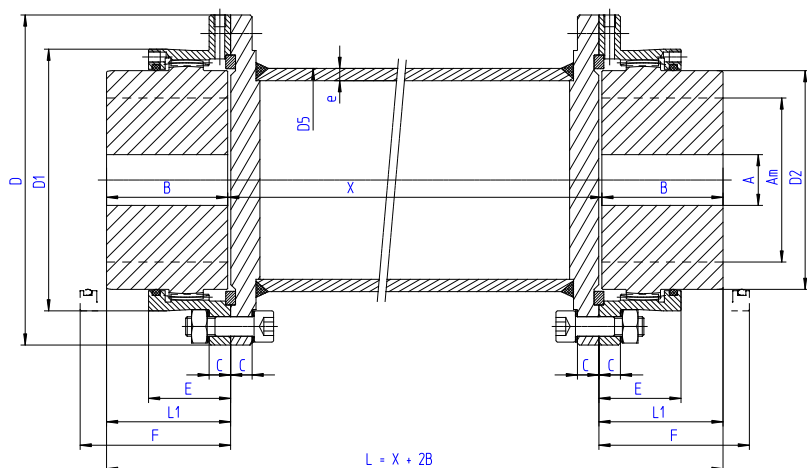

Item	Designation
1	Gear Hub
2	Half cover
3	Screws & Bolts
4	Centering ring supplied only if vertical or balanced execution
5	Seal
6	Spacer

Example of designation **S 80 E 1000**

SENIOR size **80**, composed with two half couplings **S80** joined by a tubular spacer with distance between shafts ends $X = 1000$ mm

Size		50	68	80	100	115	135	150	170	190	215	230	250	280
Nominal Torque	Nm	1200	3000	5200	9000	13700	21300	29200	43000	60700	88200	105000	138000	190000
Max Bore	Am*	50	68	80	100	115	135	150	170	190	215	230	250	280
	Am**	46	63	75	92	106	125	140	160	175	200	210	230	250
Rough bore	A	18	18	26	35	35	58	68	83	98	108	118	128	128
	B	43	50	62	76	90	105	120	135	150	175	190	220	310
	C	10	10	11	11	14	18	20	20	24	24	30	30	30
	D	105	140	169	200	228	266	298	330	368	410	440	473	498
	D1	83,6	112,6	134	164	188	219	245	277	309	351	374	407	432
	D2	69,4	95	112	138	159	188	209	238	263	302	319	349	374
	E	30,5	36	42	52	63,5	74	82	91	100	110,5	122	135,5	139
	D5	70	101,6	114,3	139,7	168,3	193,7	203	244,5	273	323,9	355,6	368	406,4
	e	4	5	6,3	8	7,1	10	12,5	12,5	12,5	12,5	12,5	16	16
	F	55	63	75	93	112	130	145	163	180	205	220	253	343
L1	44,5	51,5	63,5	78,5	92,5	108	123	139	154	179	194	225	315	
Weight •	Kg	11.6	22.1	34	55	75	121	165	218	285	390	480	628	870
Moment of Inertia J•	Kgm ²	0.013	0.045	0.093	0.218	0.407	0.883	1.42	2.45	4	7	10	15.6	21.8
Weight △	Kg	0.65	1.19	1.67	2.59	2.81	4.5	5.9	7.1	8	9.6	10.5	13.8	15.3
Moment of Inertia J△	Kgm ²	0.0007	0.0028	0.005	0.0113	0.0183	0.0383	0.0533	0.096	0.136	0.232	0.31	0.43	0.59
Weight of grease ▽	Kg	0.04	0.08	0.12	0.26	0.38	0.6	0.8	1	1.70	2.20	2.90	3.80	4

- * Bore with keyway according ISO R 773 or DIN 6885/1 standards
- ** Shrink fitting
- For couplings with spacer $X=1000$ mm: Solid hubs
- △ Correction for variation $X=100$ mm
- ▽ Per coupling

Type SE – Horizontal working position

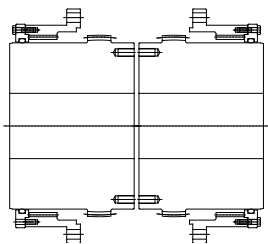
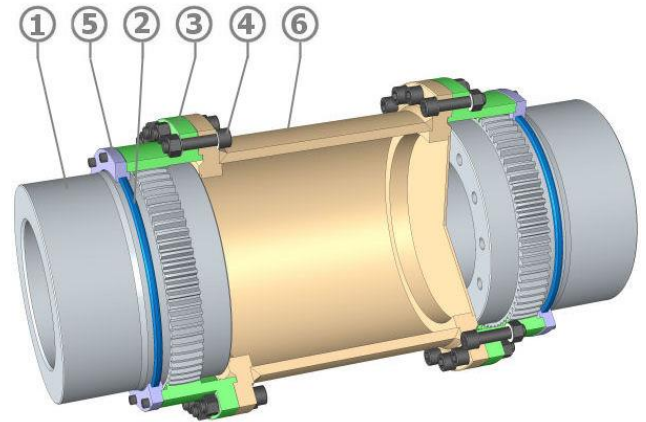
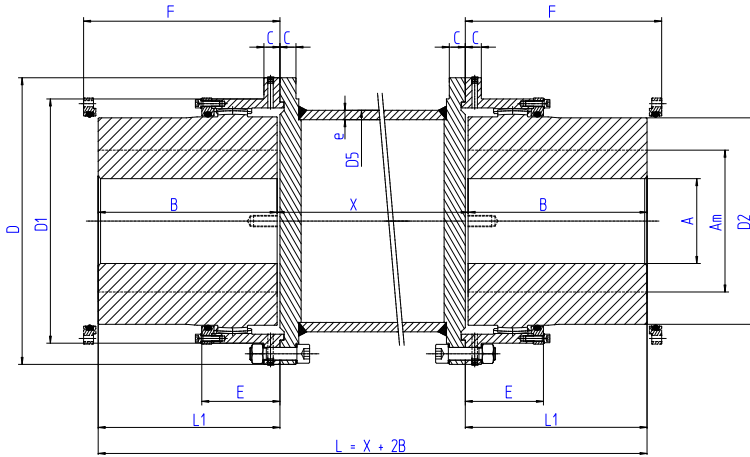

Inspection of the gear teeth is possible without having to remove the covers

Item	Designation
1	Gear Hub
2	Seal
3	Half cover
4	Screws & Bolts
5	Cover
6	Spacer

Example of designation **S 310 E 1000**

SENIOR size **310**, composed with two half couplings **S310** joined by a tubular spacer with distance between shafts ends $X = 1000$ mm

Size		310	330	370	400	430	475	510	550	610	650	710	750	800
Nominal Torque	Nm	255000	320000	410000	525000	670000	850000	1100000	1400000	1800000	2400000	3200000	3750000	4950000
Max Bore	Am*	310	330	370	400	430	475	510	550	610	650	710	750	800
	Am**	310	330	370	400	430	475	510	550	610	650	710	750	800
Rough bore	A	163	176	191	240	257	279	304	329	358	394	434	457	501
	B	310	330	350	370	430	480	505	515	535	575	610	650	700
	C	34	34	39	43	47	56	56	55	65	70	70	70	75
	D	575	608	676	735	793	940	990	1100	1225	1285	1395	1450	1555
	D1	494	518	576	637	695	785	840	910	1000	1060	1170	1225	1295
	D2	411	438	492	535	581	645	700	770	835	890	975	1030	1095
	D5	470	470	559	610	665	760	815	880	990	1030	1130	1185	1255
	e	20	20	20	20	25	25	25	30	30	40	45	45	55
	E	155	166	166	190.5	204	212	250	250	270	305	335	345	385
	F	350	370	395	420	478	550	570	575	600	640	680	720	770
L1	316	336	356	377.5	437.5	488	515	525	547.5	587.5	625	665	715	
Weight •	Kg	1185	1348	1770	2223	2983	4180	5017	6176	7841	9588	12001	13723	16841
Moment of Inertia J •	Kgm ²	38.26	46.76	78.47	117.5	183.14	337.78	457.43	676.75	1059.44	1437.35	2131.3	2626.1	3667.77
Weight Δ	Kg	22.1	22.1	26.5	29	39	49.4	57.7	62.1	69.8	86.7	107.7	127.9	151.3
Moment of Inertia J Δ	Kgm ²	1.1	1.1	1.9	2.5	3.9	5.6	8.9	11.1	15.7	22.0	32.4	42.9	57.5
Weight of grease ▽	Kg	6.2	6.62	7.9	11	13.5	18.2	22.3	23.8	30.5	37.1	48.5	62.15	73.5

- * Bore with keyway according ISO R 773 or DIN 6885/1 standards
- ** Shrink fitting
- For couplings with spacer $X=1000$ mm: Solid hubs
- Δ Correction for variation $X=100$ mm
- ▽ Per coupling

Type SDF – Horizontal working position

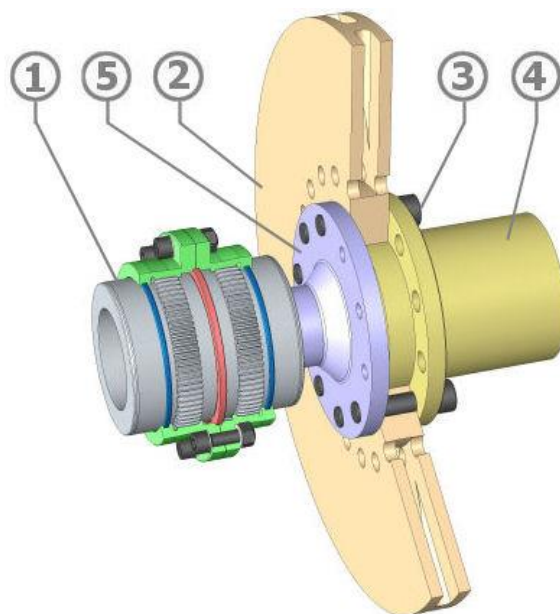
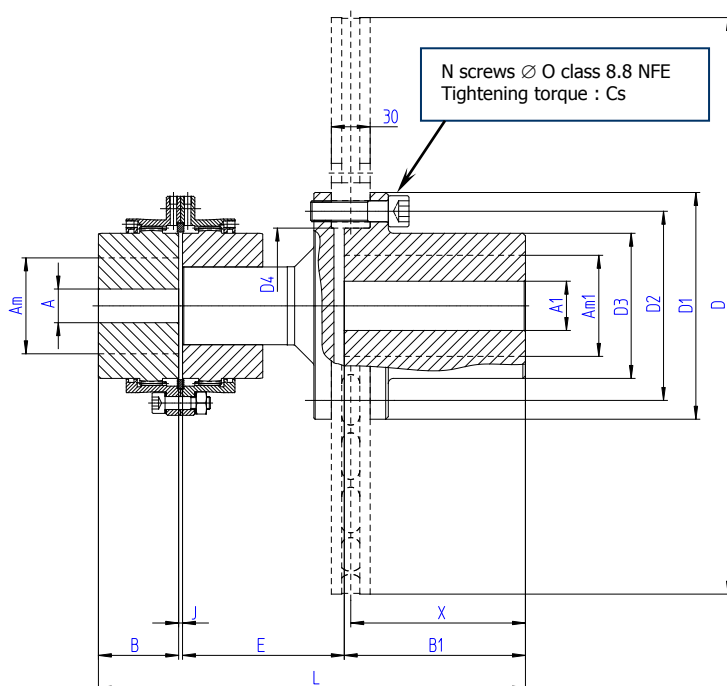

Item	Designation
1	Coupling Senior S
2	Brake disc
3	Screws & Bolts
4	Solid hub
5	Spacer

II : max speed allowed by the disc according the manufacturer. For higher speed, please consult us.

SUPPORTING DISC HUB													
D	II Min ⁻¹	A1	Am1*	Am1**	B1	D1	D2	D3	D4	N	O	Cs Nm	X
315	3000	/	50	55	107	124	105	82	85	9	M10	49	102
355	2700	/	60	70	107	145	125	100	105	9	M12	86	102
395	2400	/	70	75	107	165	140	112	115	9	M14	135	102
445	2100	/	70	80	140	175	146	112	120	12	M16	210	135
495	1900	30	100	110	140	218	190	155	160	12	M18	290	135
550	1800	30	100	110	140	218	190	155	160	12	M18	290	135
625	1500	30	105	120	140	238	205	168	170	12	M20	410	135
705	1300	30	120	135	140	268	230	190	195	12	M22	550	135
795	1200	30	135	150	140	300	260	216	220	12	M24	710	135

Example of designation **S80 DF 550**
SENIOR coupling size **80** with a **550** diameter brake disc

SIZE		68				80				100				115				135			150			170	
Disc diameter		315	355	395	445	395	445	495	550	445	495	550	625	495	550	625	705	625	705	795	625	705	795	705	795
Peak torque Max	Nm	1500	2200	2200	2200	2200	3800	3800	3800	6000	6000	6000	6000	9400	9400	9400	9400	13800	13800	13800	20700	25300	25300	29200	36700
Rough bore	A	18				26				35				35				58			68			83	
Max Bore	Am*	68				80				100				115				135			150			170	
	Am**	63				75				92				106				125			140			160	
	B	50				62				76				90				105			120			135	
	J	3				3				5				5				6			6			8	
	E	117	117	117	117	117	130	145	145	145	164	164	164	180	180	180	180	196	196	196	223	223	223	238	238
	L	274	274	274	307	286	332	347	347	361	380	380	380	410	410	410	410	441	441	441	483	483	483	513	513
Weight •	Kg	15	18	20,5	24	26	30	45	45	40	56	56	63	71	71	77	87	99	110	123	127	137	150	173	185
Moment of Inertia J •	Kgm ²	0,02	0,03	0,04	0,05	0,06	0,07	0,16	0,16	0,12	0,21	0,21	0,27	0,3	0,3	0,36	0,48	0,559	0,68	0,862	0,846	0,965	1,148	1,463	1,642
Weight of grease	Kg	0,08				0,12				0,26				0,38				0,60			0,80			1	

- * Bore with keyway according ISO R 773 or DIN 6885/1 standards
- ** Shrink fitting
- Solid hubs
- y Dynamically balanced
- ∇ Per coupling

Check that the max peak torque of the coupling is superior than the peak torque of the installation

Type SDFC – Horizontal working position

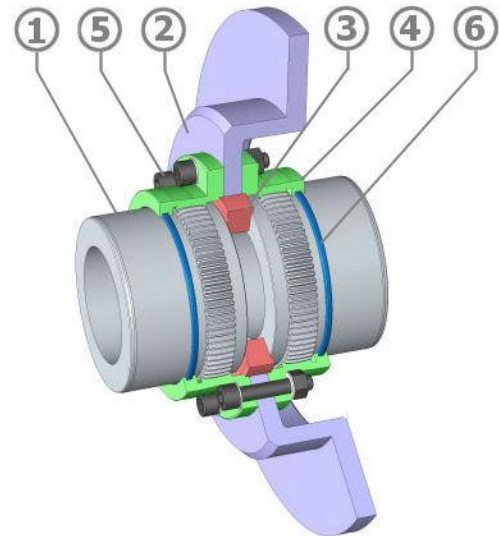
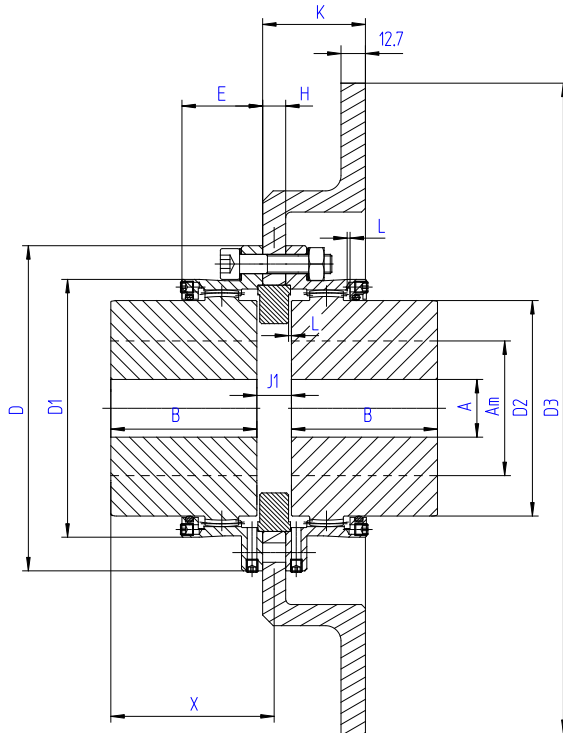

Item	Designation
1	Gear Hub
2	elbow shape brake disc
3	Centering ring spéciale
4	Half cover
5	Screws & Bolts
6	Seal

Brake disc dimensions										
D3	250	305	355	406	457	515	610	711	812	914
H	6	13	16	13	16	16	16	19	25	25
K	36	41	54							
Weight (kg)	4	7.3	10.9	14.1	19.1	22.7	33	52.3	85.5	110.9

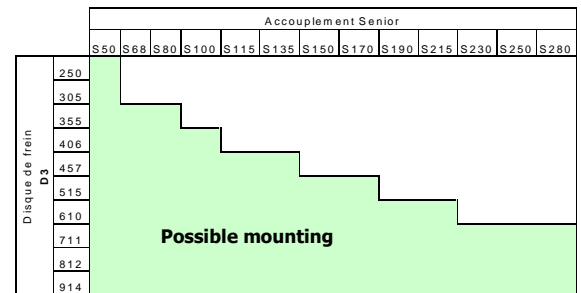

Example of designation **S80 DFC 305**
SENIOR coupling size **80** with a **305 mm** diameter elbow disc

Size		50	68	80	100	115	135	150	170	190	215	230	250	280	
Nominal Torque	Nm	1200	3000	5200	9000	13700	21300	29200	43000	60700	88200	105000	138000	190000	
Max Bore	Am*	50	68	80	100	115	135	150	170	190	215	230	250	280	
	Am**	46	63	75	92	106	125	140	160	175	200	210	230	250	
Rough bore	A	18	18	26	35	35	58	68	83	98	108	118	128	128	
	B	43	50	62	76	90	105	120	135	150	175	190	220	310	
	D	105	140	169	200	228	266	298	330	368	410	440	473	498	
	D1	83,6	112,6	134	164	188	219	245	277	309	351	374	407	432	
	D2	69,4	95	112	138	159	188	209	238	263	302	319	349	374	
	E	30,5	36	42	52	63,5	74	82	91	100	101,5	122	135,5	139	
	J1	$J1 = H + 2 L$													
	L	1.3	1.5	2	2.5	2.8	3.2	3.5	4	4.5	5	5	5.8	7.3	
	X	$X = B + (J1/2)$													
Weight •	Kg	3,7	7,7	13,2	23,5	36,7	59	84	119	164	243	300	406	616	
Moment of Inertia J •	Kgm ²	0,004	0,012	0,030	0,079	0,166	0,368	0,649	1,141	1,962	3,63	5,08	8,08	13,07	
Max speed (rpm)		5400	4000	3400	2700	2400	2000	1800	1600	1500	1300	1200	1100	1000	
	y	14000	10500	8900	7200	6300	5400	4800	4200	3800	3300	3100	2900	2700	
Weight of grease ▽	Kg	0,04	0,08	0,12	0,26	0,38	0,6	0,8	1	1,7	2,2	2,9	3,8	4	

* Bore with keyway according ISO R 773 or DIN 6885/1 standards
 ** Shrink fitting
 • Solid hubs without brake disc
 y Dynamically balanced
 ▽ Per coupling

Type SBM – Horizontal working position

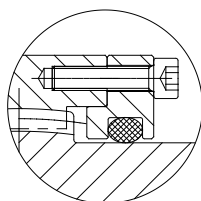
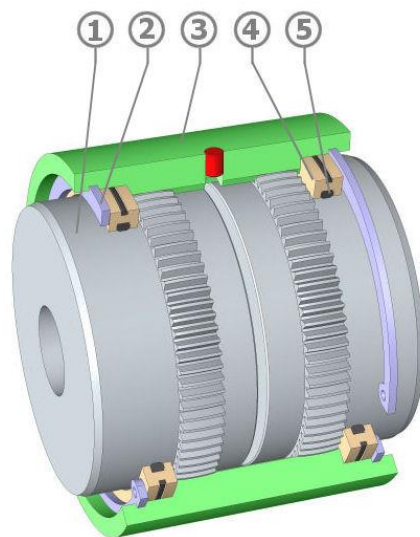
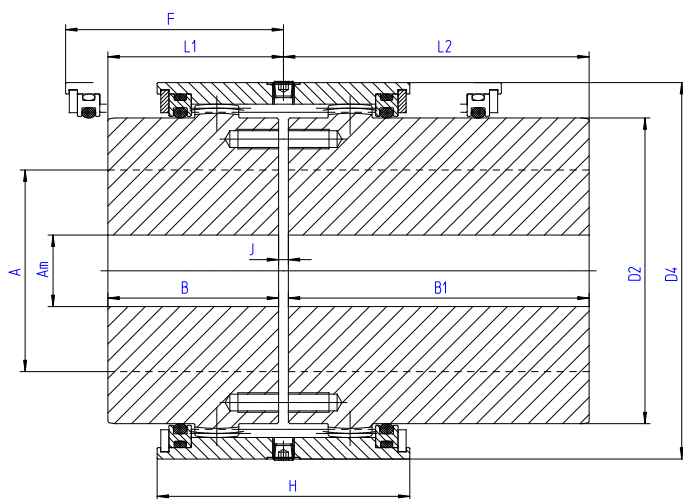

For sizes 215 up to 280

Item	Designation
1	Gear Hub
2	Stop ring
3	Monobloc ring gear cover
4	Cover
5	Seal

Example of designation **SBM80**
SENIOR coupling size 80 with monobloc cover

Size		50	68	80	100	115	135	150	170	190	215	230	250	280
Nominal Torque	Nm	1200	3000	5200	9000	13700	21300	29200	43000	60700	88200	105000	138000	190000
Max Bore	Am*	50	68	80	100	115	135	150	170	190	215	230	250	280
	Am**	46	63	75	92	106	125	140	160	175	200	210	230	250
Rough bore	A	18	18	26	35	35	58	68	83	98	108	118	128	128
	B	43	50	62	76	90	105	120	135	150	175	190	220	310
	B1	105	115	130	150	170	185	215	245	295	300	305	350	-
	D2	69,4	95	112	138	159	188	209	238	263	302	319	349	374
	D4	95	125	144	177	204	246	265	292	324	360	383	417	442
	L1	44,5	51,5	63,5	78,5	92,5	108	123	139	154	179	194	225	-
	L2	106,5	116,5	131,5	152,5	172,5	188	218	249	299	304	309	355	-
	J	3	3	3	5	5	6	6	8	8	8	8	10	10
	F	63	72	86	104	122	145	161	177	193	199	219	252	342
	H	78	92	106	128	152	181	198	216	234	195	218	245	252
Weight Kg •	SBM	3.9	8.3	13.6	24.9	39.5	67	88.5	122.5	165	237.6	287.7	394.3	605.3
	SBML	5.8	11.9	18.9	33.5	51.8	84.2	114	160.6	226.6	307.4	359.5	491.6	-
	SBML2	7.6	15.5	24.1	42.2	64.1	101.5	139.5	198.7	288.2	377.1	431.4	588.8	-
Moment of Inertia J • Kgm ²	SBM	0.004	0.015	0.032	0.09	0.19	0.47	0.71	1.18	1.95	2.85	3.86	6.31	10.94
	SBML	0.075	0.12	0.16	0.26	0.41	0.78	1.15	1.86	3.03	4.54	5.87	9.49	-
	SBML2	0.15	0.22	0.28	0.43	0.63	1.10	1.59	2.54	4.1	6.22	7.87	12.66	-
Max speed (rpm)		5400	4000	3400	2700	2400	2000	1800	1600	1500	1300	1200	1100	1000
	y	14000	10500	8900	7200	6300	5400	4800	4200	3800	3300	3100	2900	2700
Weight of grease ▽	Kg	0,04	0,08	0,12	0,26	0,38	0,6	0,8	1	1,7	2,2	2,9	3,8	4

- * Bore with keyway according ISO R 773 or DIN 6885/1 standards
- ** Shrink fitting
- Solid hubs
- y Dynamically balanced
- ▽ Per coupling

Type SBM – Horizontal working position

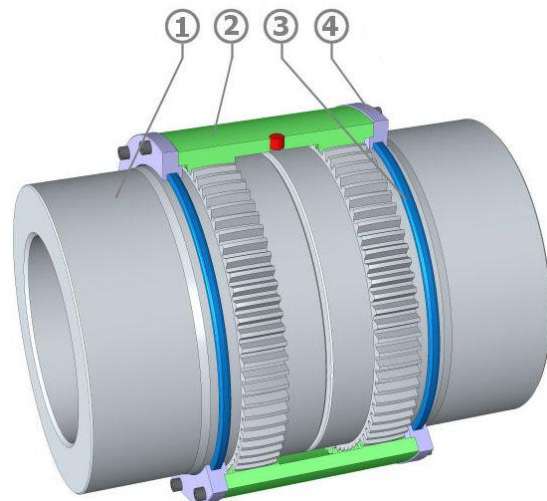
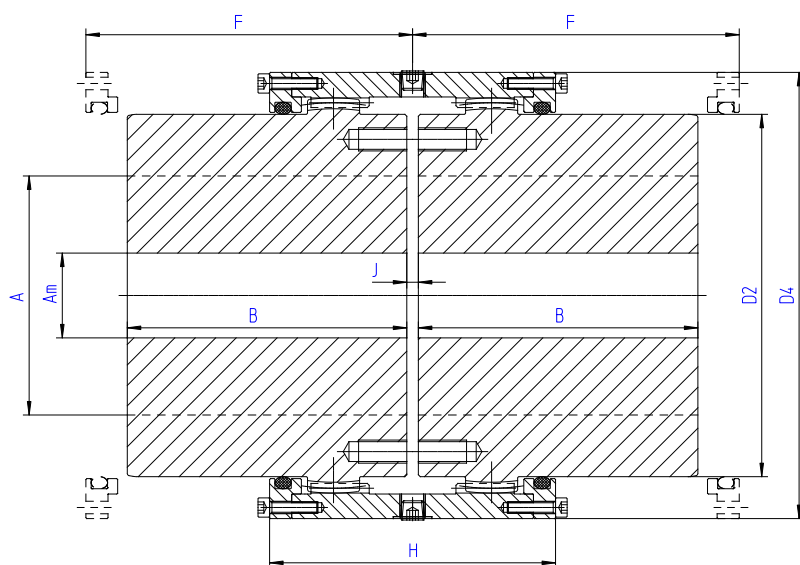

Item	Designation
1	Gear Hub
2	Monobloc ring gear cover
3	Seal
4	Cover

Example of designation **SBM310**
SENIOR coupling size **310** with monobloc cover

Size		310	330	370	400	430	475	510	550	610	650	710	750	800	
Nominal Torque	Nm	255000	320000	410000	525000	670000	850000	1100000	1400000	1800000	2400000	3200000	3750000	4950000	
Max Bore	Am*	310	330	370	400	430	475	510	550	610	650	710	750	800	
	Am**	310	330	370	400	430	475	510	550	610	650	710	750	800	
Rough bore	A	163	176	191	240	257	279	304	329	358	394	434	457	501	
	B	310	330	350	370	430	480	505	515	535	575	610	650	700	
	D2	411	438	492	535	581	645	700	770	835	890	975	1030	1095	
	D4	494	518	576	637	695	785	840	910	1000	1060	1170	1225	1295	
	J	12	12	12	15	15	16	20	20	25	25	30	30	30	
	F	350	370	395	420	478	550	570	575	600	640	680	720	770	
	H	310	332	332	381	408	424	500	500	540	610	670	690	770	
	Weight •	Kg	761	908	1190	1531	2083	2882	3605	4372	5374	6559	8411	9867	12056
	Moment d'Inerie J•	Kgm ²	18	24	39.3	60.8	97.1	167.3	244.1	353.9	520.3	719.5	1117.3	1447.5	1983.5
Max speed (rpm)		903	857	760	696	643	573	542	495	446	418	377	358	341	
	y	2409	2285	2026	1857	1714	1528	1445	1320	1188	1114	1005	955	909	
Weight of grease ▽	Kg	6.2	6.6	7.9	11	13.5	18.2	22.3	23.8	30.5	37.1	48.5	62.2	73.5	

* Bore with keyway according ISO R 773 or DIN 6885/1 standards
 ** Shrink fitting
 • Solid hubs
 y Dynamically balanced
 ▽ Per coupling

Type JL – Horizontal working position Limited end float model

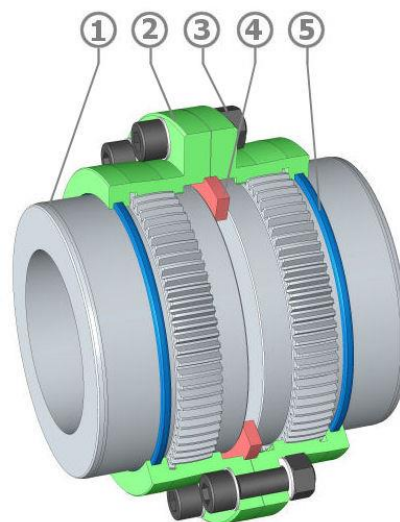
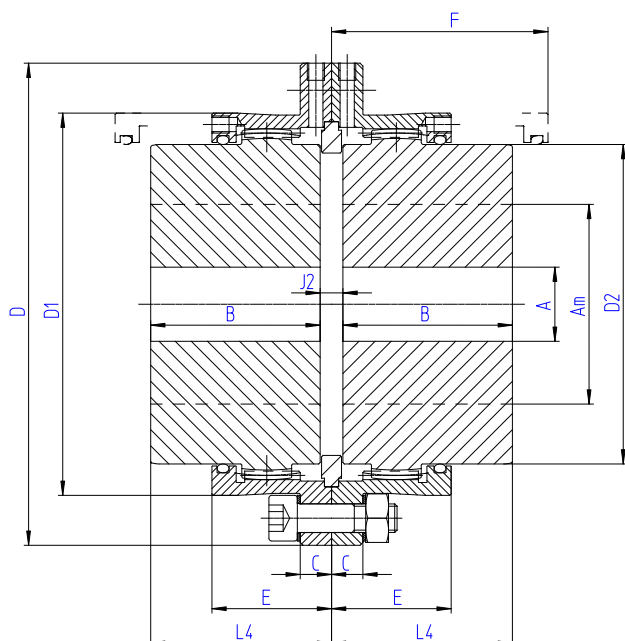

Item	Designation
1	Gear Hub
2	Half cover
3	Screws & Bolts
4	Specific centering ring
5	Seal

Example of designation **S 80 JL SENIOR** coupling size **80** whose axial movement is reduced by a specific centering ring between the two hubs.
The misalignment capacities are reduced

Size		50	68	80	100	115	135	150	170	190	215	230	250	280
Nominal Torque	Nm	1200	3000	5200	9000	13700	21300	29200	43000	60700	88200	105000	138000	190000
Max bore	Am*	50	68	80	100	115	135	150	170	190	215	230	250	280
	Am**	46	63	75	92	106	125	140	160	175	200	210	230	250
Rough bore	A	18	18	26	35	35	58	68	83	98	108	118	128	128
	B	43	50	62	76	90	105	120	135	150	175	190	220	310
	C	10	10	11	11	14	18	20	20	24	24	30	30	30
	D	105	140	169	200	228	266	298	330	368	410	440	473	498
	D1	83,6	112,6	134	164	188	219	245	277	309	351	374	407	432
	D2	69,4	95	112	138	159	188	209	238	263	302	319	349	374
	E	30,5	36	42	52	63,5	74	82	91	100	110,5	122	135,5	139
	J2	4,6	5,4	6	9	9,6	11,4	12	14	15	16	16,6	19,6	22,6
Jeu axial	+/-	1	1	1	1	1	1	1	2	2	2	2	2	2
	F2	57	65	78	97	117	135	150	170	190	215	230	263	355
	L4	45,3	52,7	65	80,5	94,8	110,7	126	142	157,5	183	198,3	229,8	321,3
Weight •	Kg	3,7	7,7	13,2	23,6	37	60	85	120	165	244	302	408	619
Moment of Inertia J•	Kgm²	0,004	0,012	0,030	0,080	0,167	0,371	0,655	1,151	1,978	3,66	5,22	8,14	13,16
Max speed (rpm)	y	5400	4000	3400	2700	2400	2000	1800	1600	1500	1300	1200	1100	1000
		14000	10500	8900	7200	6300	5400	4800	4200	3800	3300	3100	2900	2700
Weight of grease ▽	Kg	0,04	0,09	0,14	0,30	0,46	0,73	1	1,20	2	2,70	3,50	4,60	5

* Bore with keyway according ISO R 773 or DIN 6885/1 standards
 ** Shrink fitting
 • Solid hubs
 y Dynamically balanced
 ▽ Per coupling

Type ML – ML2 – Horizontal working position

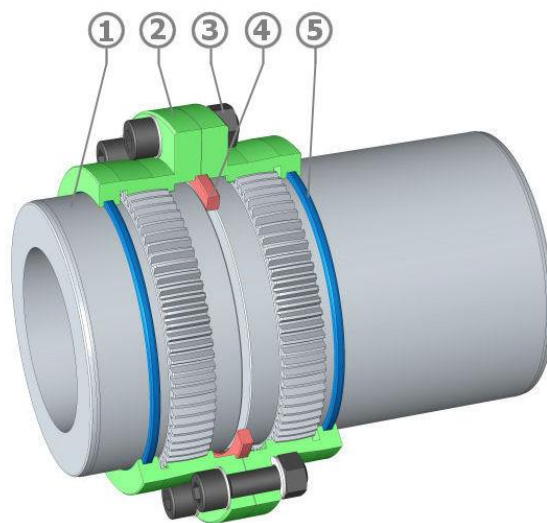
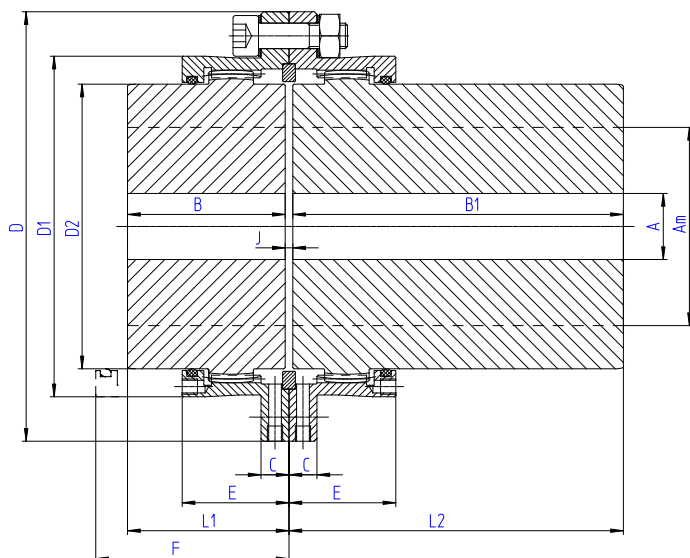

Item	Designation
1	Gear Hub
2	Half cover
3	Screws & Bolts
4	Centering ring supplied only if vertical or balanced execution
5	Seal

Example of designation **S 80 ML SENIOR** coupling size **80** with long hub

Size		50	68	80	100	115	135	150	170	190	215	230	250
Nominal Torque	Nm	1200	3000	5200	9000	13700	21300	29200	43000	60700	88200	105000	138000
Max Bore	Am*	50	68	80	100	115	135	150	170	190	215	230	250
	Am**	46	63	75	92	106	125	140	160	175	200	210	230
Rough bore	A	18	18	26	35	35	58	68	83	98	108	118	128
	B	43	50	62	76	90	105	120	135	150	175	190	220
	B1	105	115	130	150	170	185	215	245	295	300	305	350
	C	10	10	11	11	14	18	20	20	24	24	30	30
	D	105	140	169	200	228	266	298	330	368	410	440	473
	D1	83,6	112,6	134	164	188	219	245	277	309	351	374	407
	D2	69,4	95	112	138	159	188	209	238	263	302	319	349
	E	30,5	36	42	52	63,5	74	82	91	100	110,5	122	135,5
	J	3	3	3	5	5	6	6	8	8	8	8	10
	F	55	63	75	93	112	130	145	163	180	205	220	253
	L1	44,5	51,5	63,5	78,5	92,5	108	123	139	154	179	194	225
	F	117	128	143	167	192	210	240	273	325	330	335	383
	L2	106,5	116,5	131,5	152,5	172,5	188	218	249	299	304	309	355
Weight Kg•	SML	5,5	11,2	18,4	32	49	77	110	157	226	313	373	503
	SML2	7,3	14,7	23,6	40,5	61,3	95	136	195	288	382	446	600
Moment d'Inerie J•	SML	0,005	0,016	0,038	0,099	0,204	0,443	0,785	1,407	2,485	4,42	6,08	9,54
	SML2	0,006	0,020	0,046	0,119	0,242	0,518	0,921	1,673	3,008	5,21	6,98	11
Max speed (rpm)		5400	4000	3400	2700	2400	2000	1800	1600	1500	1300	1200	1100
	y	14000	10500	8900	7200	6300	5400	4800	4200	3800	3300	3100	2900
Weight of grease ▽	Kg	0,04	0,08	0,12	0,26	0,38	0,60	0,80	1	1,70	2,20	2,90	3,80

- * Bore with keyway according ISO R 773 or DIN 6885/1 standards
- ** Shrink fitting
- Solid hubs
- y Dynamically balanced
- ▽ Per coupling

Type V – Vertical working position

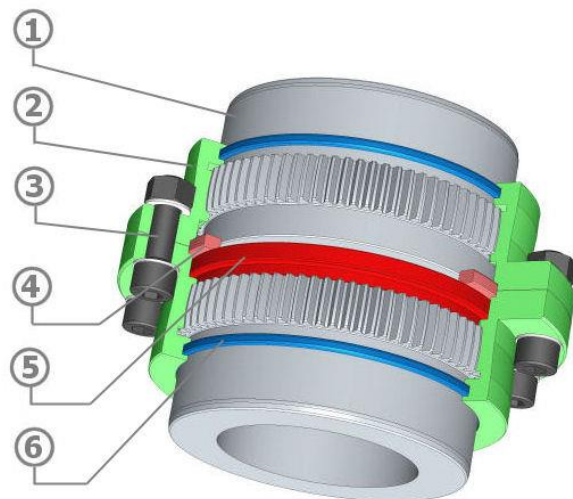
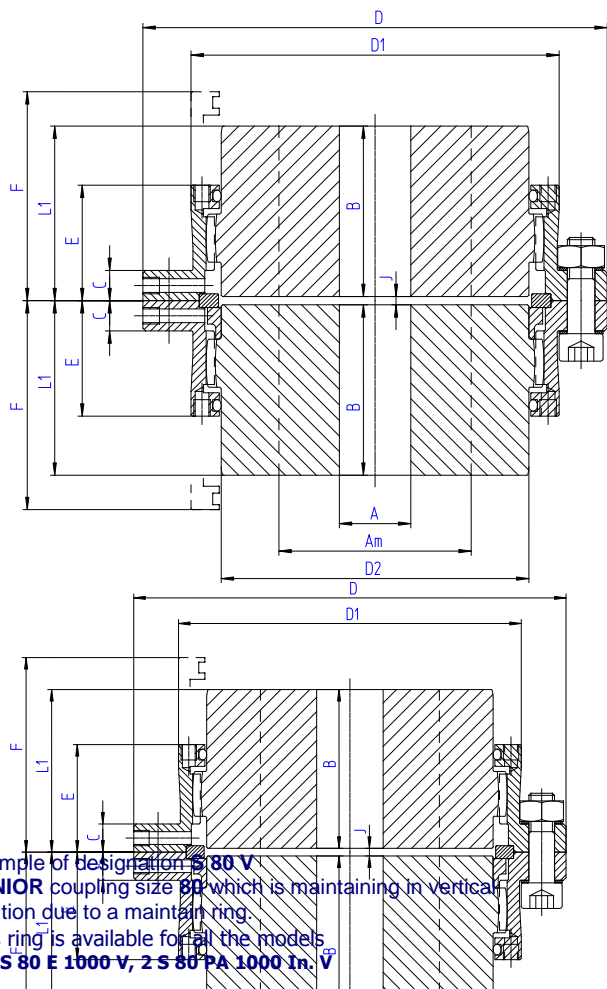

Item	Designation
1	Gear Hub
2	Half cover
3	Screws & Bolts
4	Centering ring
5	Maintaining ring
6	Seal

Example of designation **S 80 V SENIOR** coupling size 80 which is maintaining in vertical position due to a maintain ring. This ring is available for all the models.
Ex : **S 80 E 1000 V**, **2 S 80 PA 1000 In. V**

Size		50	68	80	100	115	135	150	170	190	215	230	250	280	
Nominal Torque	Nm	1200	3000	5200	9000	13700	21300	29200	43000	60700	88200	105000	138000	190000	
Max bore	Am*	50	68	80	100	115	135	150	170	190	215	230	250	280	
	Am**	46	63	75	92	106	125	140	160	175	200	210	230	250	
Rough bore	A	18	18	26	35	35	58	68	83	98	108	118	128	128	
	B	43	50	62	76	90	105	120	135	150	175	190	220	310	
	C	10	10	11	11	14	18	20	20	24	24	30	30	30	
	D	105	140	169	200	228	266	298	330	368	410	440	473	498	
	D1	83,6	112,6	134	164	188	219	245	277	309	351	374	407	432	
	D2	69,4	95	112	138	159	188	209	238	263	302	319	349	374	
	E	30,5	36	42	52	63,5	74	82	91	100	110,5	122	135,5	139	
	J	3	3	3	5	5	6	6	8	8	8	8	10	10	
	F	55	63	75	93	112	130	145	163	180	205	220	253	343	
	L1	44,5	51,5	63,5	78,5	92,5	108	123	139	154	179	194	225	315	
	Weight •	Kg	3,7	7,7	13,3	23,7	37	60	85	121	166	245	304	410	621
	Moment of Inertia J•	Kgm ²	0,004	0,012	0,030	0,08	0,169	0,374	0,659	1,161	1,997	3,69	5,28	8,23	13,26
Max speed (rpm)		5400	4000	3400	2700	2400	2000	1800	1600	1500	1300	1200	1100	1000	
	y	14000	10500	8900	7200	6300	5400	4800	4200	3800	3300	3100	2900	2700	
Weight of grease ∇	kg	0,03	0,07	0,10	0,22	0,34	0,50	0,70	0,90	1,40	1,90	2,50	3,20	3,4	

* Bore with keyway according ISO R 773 or DIN 6885/1 standards
 ** Shrink fitting
 • Solid hubs
 y Dynamically balanced
 ∇ Per coupling

Type SDB – Horizontal working position

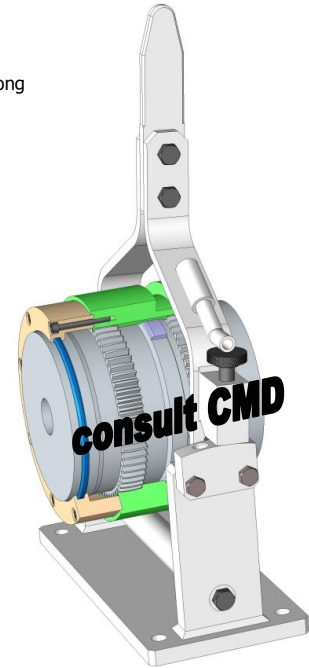
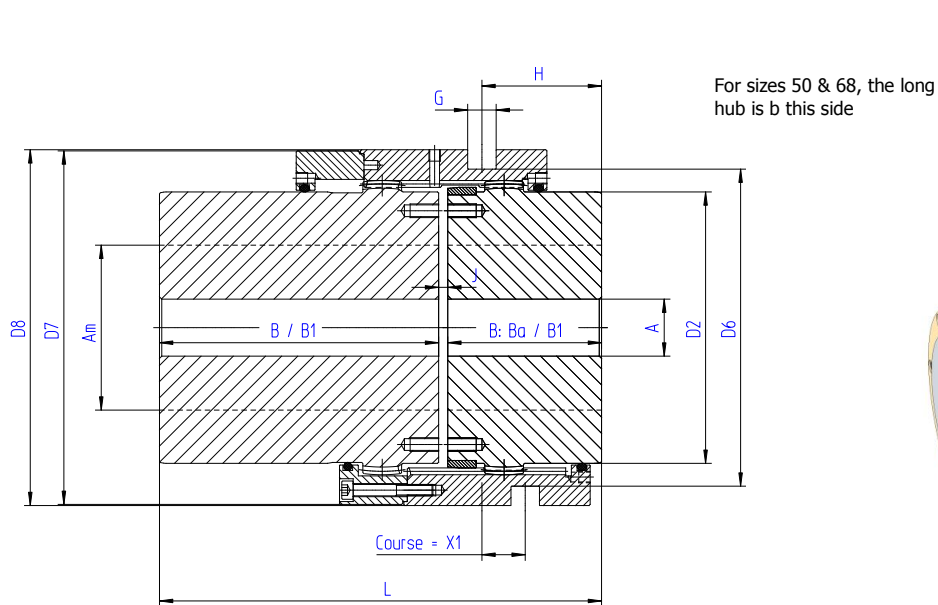

Example of designation **S 80 MLDB**
SENIOR clutch coupling size **80** with one long hub.

Size		Manual		With acting system									
		50	68	80	100	115	135	150	170	190	215	230	250
Nominal Torque	Nm	1200	3000	5200	9000	13700	21300	29200	43000	60700	88200	105000	138000
Max Bore	Am*	50	68	80	100	115	135	150	170	190	215	230	250
	Am**	46	63	75	92	106	125	140	160	175	200	210	230
Rough bore	A	18	18	26	35	35	58	68	83	98	108	118	128
	B : Ba	43 : 62	50 : 72	62	76	90	105	120	135	150	175	190	220
	B1	105	115	130	150	170	185	215	245	295	300	305	350
	D2	69,4	95	112	138	159	188	209	238	263	302	319	349
	D6	/	/	132	164	189	222	246	278	312	353	376	406
	D7	100	128	148	190	210	240	270	310	330	390	10	440
	D8	102	130	148	188	213	246	280	312	346	397	420	450
	G	/	/	12	18	18	18	25	25	25	32	32	32
	H	/	/	50	60	70	82	90	105	115	135	145	170
	J	3	3	3	5	5	6	6	8	8	8	8	10
	X1	11	14	19	22	25	29	32	38	40	48	50	55
Models	S..DB	108	125	127	157	185	216	246	278	308	358	388	450
	S..MLDB	151 : 170	168 : 190	195	231	265	296	341	388	453	483	503	580
	S..ML2DB	213	233	263	305	345	376	436	498	598	608	618	710
Weight Kg•	S..DB	-	-	14.4	26.1	43.5	68.1	97	138.7	185			
	S..MLDB	-	-	19.7	34.7	55.9	85.5	122.5	177	246.6			
	S..ML2DB	-	-	25	43.8	68.3	102.9	148	215.6	308.2			
Moment of Inertia J•	S..DB	-	-	0.036	0.108	0.227	0.489	0.854	1.540	2.469			
	S..MLDB	-	-	0.044	0.128	0.366	0.565	0.993	1.810	3.001			
	S..ML2DB			0.052	0.196	0.405	0.641	1.132	2.082	3.533			
Max speed (rpm)	Ω	2500	2000	1300	1100	890	780	680	610	550	480	450	420
Weight of grease ▽	Kg	0,04	0,08	0,12	0,26	0,38	0,60	0,80	1	1,70	2,20	2,90	3,80

- * Bore with keyway according ISO R 773 or DIN 6885/1 standards
- ** Shrink fitting
- Solid hubs
- Ω for higher speed, please consult us
- ▽ Per coupling

Type SR – Horizontal working position

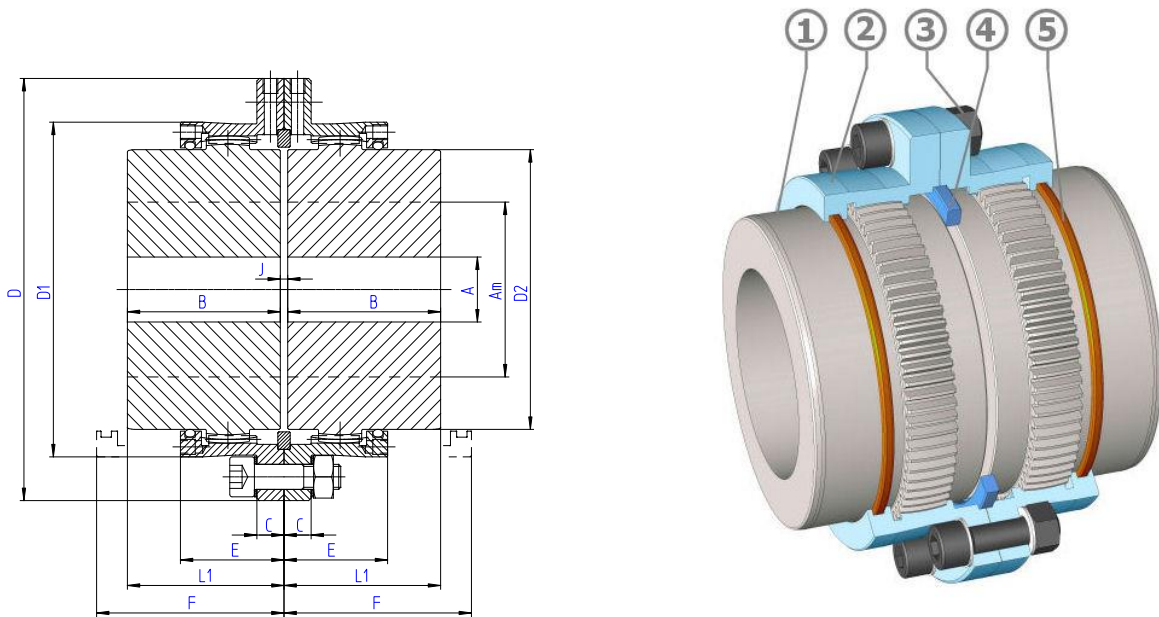

Item	Designation
1	Gear Hub
2	Half cover
3	Screws & Bolts
4	Centering ring supplied only if vertical or balanced execution
5	Seal

Example of designation **S80R**
SENIOR coupling Reinforced (42 CrMo4) size 80

Size		50	68	80	100	115	135	150	170	190	215	230	250	280
Nominal Torque	Nm	1855	4570	7910	13635	20740	32220	44000	65110	91865	133490	159160	207000	302450
Max Bore	Am*	50	68	80	100	115	135	150	170	190	215	230	250	280
	Am**	46	63	75	92	106	125	140	160	175	200	210	230	250
Rough bore	A	18	18	26	35	35	58	68	83	98	108	118	128	128
	B	43	50	62	76	90	105	120	135	150	175	190	220	310
	C	10	10	11	11	14	18	20	20	24	24	30	30	30
	D	105	140	169	200	228	266	298	330	368	410	440	473	498
	D1	83,6	112,6	134	164	188	219	245	277	309	351	374	407	432
	D2	69,4	95	112	138	159	188	209	238	263	302	319	349	374
	E	30,5	36	42	52	63,5	74	82	91	100	110,5	122	135,5	139
	J	3	3	3	5	5	6	6	8	8	8	8	10	10
	F	55	63	75	93	112	130	145	163	180	205	220	253	343
	L1	44,5	51,5	63,5	78,5	92,5	108	123	139	154	179	194	225	315
Weight •	Kg	3,7	7,7	13,2	23,5	36,7	59	84	119	164	243	300	406	616
Moment of Inertia J •	Kgm ²	0,004	0,012	0,030	0,079	0,166	0,368	0,649	1,141	1,962	3,63	5,08	8,08	13,07
Max speed (rpm)		5400	4000	3400	2700	2400	2000	1800	1600	1500	1300	1200	1100	1000
	y	14000	10500	8900	7200	6300	5400	4800	4200	3800	3300	3100	2900	2700
Weight of grease ∇	Kg	0,04	0,08	0,12	0,26	0,38	0,6	0,8	1	1,7	2,2	2,9	3,8	4

- * Bore with keyway according ISO R 773 or DIN 6885/1 standards
- ** Shrink fitting
- Solid hubs
- y Dynamically balanced
- ∇ Per coupling

Type SR – Horizontal working position

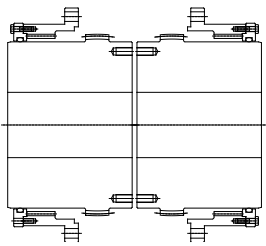
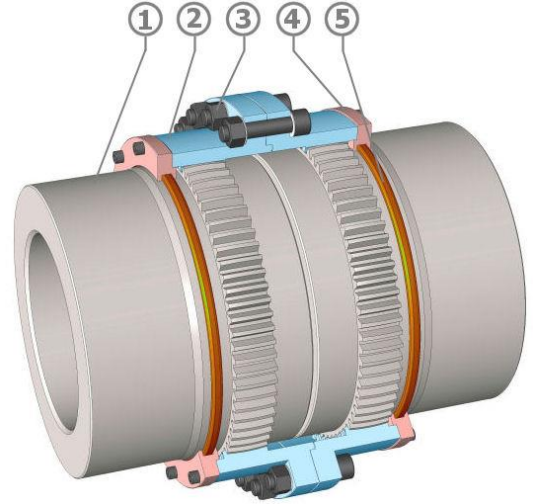
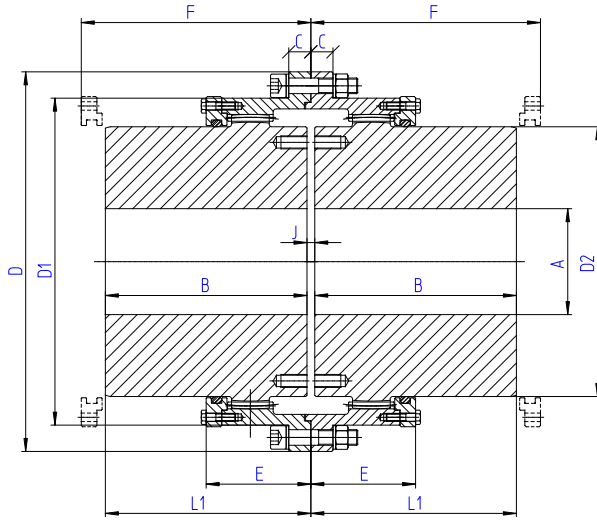

Inspection of the gear teeth is possible without having to remove the covers

Item	Designation
1	Gear Hub
2	Half cover
3	Screws & Bolts
4	Cover
5	Seal

Example of designation **S310R**
SENIOR coupling Reinforced (42 CrMo4) size **310**

Size		310	330	370	400	430	475	510	550	610	650	710	750	800
Nominal Torque	Nm	400000	500850	637500	848540	1078000	1356400	1714000	2211000	2830000	3770000	5000100	5890000	7780000
Max Bore	Am*	310	330	370	400	430	475	510	550	610	650	710	750	800
	Am**	310	330	370	400	430	475	510	550	610	650	710	750	800
Rough bore	A	163	176	191	240	257	279	304	329	358	394	434	457	501
	B	310	330	350	370	430	480	505	515	535	575	610	650	700
	C	34	34	39	43	47	56	56	55	65	70	70	70	75
	D	575	608	676	735	793	940	990	1100	1225	1285	1395	1450	1555
	D1	494	518	576	637	695	785	840	910	1000	1060	1170	1225	1295
	D2	411	438	492	535	581	645	700	770	835	890	975	1030	1095
	E	155	166	166	190.5	204	212	250	250	270	305	335	345	385
	J	12	12	12	15	15	16	20	20	25	25	30	30	30
	F	350	370	395	420	478	550	570	575	600	640	680	720	770
	L1	316	336	356	377.5	437.5	488	515	525	547.5	587.5	625	665	715
Weight •	Kg	805	957	1261	1613	2191	3091	3825	4676	5833	7101	9025	10522	12927
Moment of Inertia J•	Kgm²	21.9	29.1	47.6	74.1	116.9	215.3	307.4	449.9	687.4	936	1419.4	1795.7	2512.1
		903	857	760	696	643	573	542	495	446	418	377	358	341
Max speed (rpm)	y	2409	2285	2026	1857	1714	1528	1445	1320	1188	1114	1005	955	909
Weight of grease ▽	Kg	6.2	6.6	7.9	11	13.5	18.2	22.3	23.8	30.5	37.1	48.5	62.2	73.5

* Bore with keyway according ISO R 773 or DIN 6885/1 standards
 ** Shrink fitting
 • Solid hubs
 y Dynamically balanced
 ▽ Per coupling