



**brevetti
stendalto**

**brevetti
stendalto**
DYNAMIC CABLE PROTECTION

Brevetti Stendalto S.p.A.
20900 Monza
Viale Giovanni Battista Stucchi 66/8
Tel. +39 039 20.49.01
Fax +39 039 83.42.50
E-mail: info@brevettistendalto.it

WWW.BREVETTISTENDALTO.COM

STEEL Light



Steel Cable Chains Steel Series

20LT Series	pag. 200
20LC Series	pag. 202
30LT Series	pag. 204
30LC Series	pag. 206
35LT Series	pag. 208
35LC Series	pag. 210
40LT Series	pag. 212
40LC Series	pag. 214
42LT Series	pag. 216
45T Series	pag. 218

*Completely enclosed design
to protect chain contents from
steel and wood chips, dust, etc.*

*Opening
and removable
cover frames*

*Large selection
of chain-frames:
- aluminium draw plates
cut to size;
- aluminium drilled
frames, according
to customer drawings*

*Special tough construction
with double spring washer,
antifriction plates
and rivet fixing*

Cable drag chains in steel for long travel distance	pag. 220
Special offshore applications	pag. 225

20LT Bright Zinc Plated Steel chain with aluminium frame

Inner height (D) 32 mm

Bright Zinc Plated Steel chain¹.
Aluminium draw plates with nylon separator or Aluminium split cross piece created by design. A both can mounted every second links.

Alu-draw frames are standard mounted and every link. You can request the quote C with special quote.

⁽¹⁾ available in Stainless Steel.

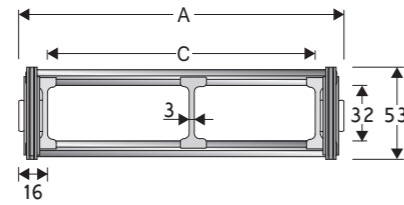

Separator

- Unassembled	Part.no S20LTF
- Assembled	Part.no S20LTFMC

Technical characteristics when self-supported

Speed	0,5 m/s
Acceleration	2 m/s ²

For higher requirements please consult our technical dept.

For sliding applications, characteristics techniques may vary depending on the frequency, added weight and work environment.

Aluminium frames with nylon separators

A	B	C	D	R	Weight/m	Chain
mm	mm	mm	mm	mm	kg	Part Number
111	53	79	32	075-115-150-205-250-305	4,41	20LT079 □□□ *
136	53	104	32	075-115-150-205-250-305	4,56	20LT104 □□□ *
186	53	154	32	075-115-150-205-250-305	4,86	20LT154 □□□ *
236	53	204	32	075-115-150-205-250-305	5,15	20LT204 □□□ *
286	53	254	32	075-115-150-205-250-305	5,45	20LT254 □□□ *
336	53	304	32	075-115-150-205-250-305	5,75	20LT304 □□□ *
C+32	53	32	075-115-150-205-250-305		20LT □□□□□ **

*Complete the code by inserting the value of the radius (R): Ex. 20LT154 □□□ □

**Complete the code by inserting the value of the quote C and the radius (R): Ex 20LT □ □ □ □ □ □ □

Chain equipped with aluminium draw plates every pitch: complete the code by inserting the letter D: Es. 20LT154250 □

Machined Cross Frame

Machined cross frames 20LA available on request for bending radius listed below. Custom solutions for machined cross frames realization, based on customer's and/or specific requirements. Please contact Brevetti Stendalto's Technical Department for further information.

R	H*	N	M	N1	M1
mm	mm	mm	mm	mm	mm
075	216	180	390	-	-
115	296	220	515	500	1080
150	366	255	625	675	1485
205	476	310	795	885	2005
250	566	360	940	1030	2385
305	676	410	1110	1190	2825

* The height H should be increased by 10 mm/m approx. because of preload. In case of limitation to available space, refer to the Technical Dptm.

Self-Supporting Capacity Diagram

The maximum length of the self-supporting capacity ($\frac{LS}{2}$) in relationship to the weight of the cables and hoses contained per linear metre.

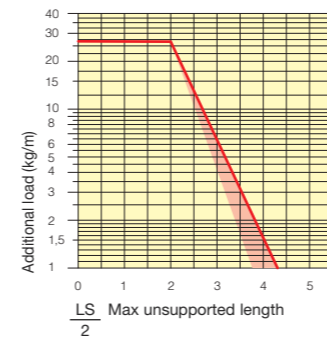

Bright Zinc Plated Steel End Brackets

The end brackets set containing four steel plates screwed to the links allows the two ends of the chain to be attached to the equipment.

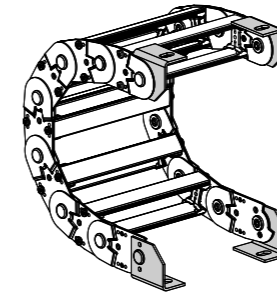
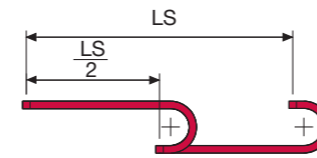
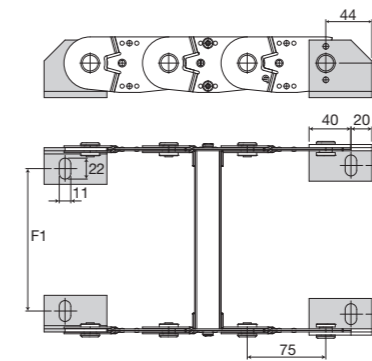

Fig. A
Chain fixed inner/outer the radius (Fig A)



The red marking in the diagram area considers the difference of weight between various widths of chain.

For applications with $\frac{LS}{2}$ and weights not included in the area of the diagram showing self-supporting capacity, verify the possible use of support rollers (see page 30).



Chain type	F1 mm	F2 mm
20LT079	61	67
20LT104	86	92
20LT154	136	142
20LT204	186	192
20LT254	236	242
20LT304	286	292

Special widths
F1=A-50 F2=A-44

Bright Zinc Plated Steel Type Part Numbers

Complete Set Assembled	Chain	End Brackets
type	Set	Set
20LT...		A20LKM □ **

Complete Set Unassembled	Chain	End Brackets
type	Set	Set
20LT ...		A20LK

** 1=Pos.1; 2=Pos.2; 3=Pos.3

20LT Bright Zinc Plated Steel chain with aluminium frame



Suitable to long travel distance.
See page 220

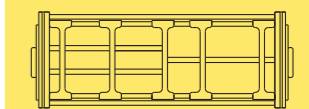

Supplementary movable separators.

For further information please consult Brevetti Stendalto's Technical Office



20LC

Bright Zinc Plated Steel chain with aluminium covers

Inner height (D) 31 mm

Bright Zinc Plated Steel chain¹. The cover is of Aluminium.

You can request the quote C with special quote.

⁽¹⁾ available in Stainless Steel.

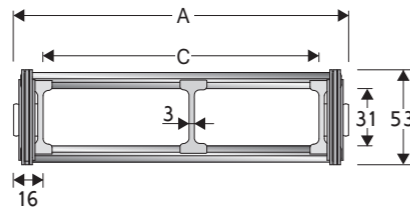

Separator

- Unassembled	Part.no S20LTF
- Assembled	Part.no S20LTFMC

Technical characteristics when self-supported

Speed	0,5 m/s
Acceleration	2 m/s ²

For higher requirements please consult our technical dept.

For sliding applications, characteristics techniques may vary depending on the frequency, added weight and work environment.

Aluminium draw Plates with Nylon Separators

A	B	C	D	R	Weight/m	Chain
mm	mm	mm	mm	mm	kg	Part Number
111	53	79	31	115-150-205-250-305	5,73	20LC079 □□□ *
136	53	104	31	115-150-205-250-305	6,21	20LC104 □□□ *
186	53	154	31	115-150-205-250-305	7,18	20LC154 □□□ *
236	53	204	31	115-150-205-250-305	8,15	20LC204 □□□ *
286	53	254	31	115-150-205-250-305	9,12	20LC254 □□□ *
336	53	304	31	115-150-205-250-305	10,09	20LC304 □□□ *
C+32	53	31	115-150-205-250-305		20LC □□□□□□ **

*Complete the code by inserting the value of the radius (R): Ex. 20LC154 □ □ □ □

**Complete the code by inserting the value of the quote C and the radius (R): Ex. 20LC □ □ □ □ □ □ □ □

R	H*	N	M	N1	M1
mm	mm	mm	mm	mm	mm
115	296	220	515	500	1080
150	366	255	625	675	1485
205	476	310	795	885	2005
250	566	360	940	1030	2385
305	676	410	1110	1190	2825

* The height H should be increased by 10 mm/m approx. because of preload. In case of limitation to available space, refer to the Technical Dptm.

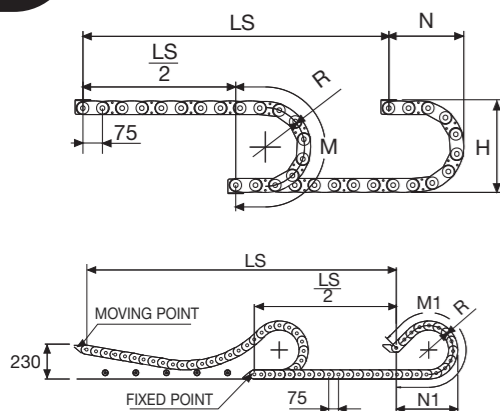

Length of chain (L)
Half travel distance ($\frac{LS}{2}$)
plus length of curve (M) or (M1)

$$L = \frac{LS}{2} + M \text{ or } M1$$

Self-Supporting Capacity Diagram

The maximum length of the self-supporting capacity ($\frac{LS}{2}$) in relationship to the weight of the cables and hoses contained per linear metre.

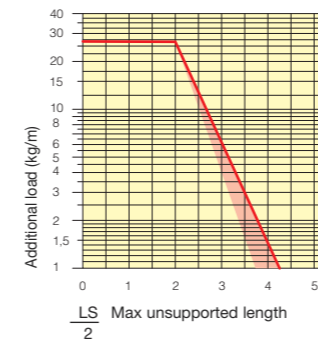

Bright Zinc Plated Steel End Brackets

The end brackets set containing four steel plates screwed to the links allows the two ends of the chain to be attached to the equipment.

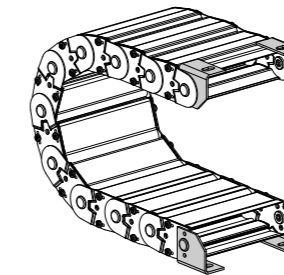
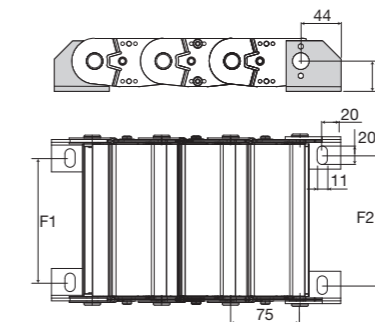
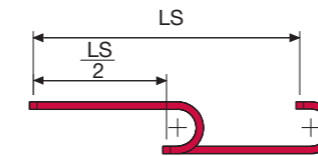

Fig. A Chain fixed outer radius (Fig A)



The red marking in the diagram area considers the difference of weight between various widths of chain.

For applications with $\frac{LS}{2}$ and weights not included in the area of the diagram showing self-supporting capacity, verify the possible use of support rollers (see page 30).

Chain type	F1 mm	F2 mm
20LC079	61	67
20LC104	86	92
20LC154	136	142
20LC204	186	192
20LC254	236	242
20LC304	286	292

Special widths
F1=A-50 F2=A-44

Bright Zinc Plated Steel Type Part Number

Complete Set Assembled Chain type	End Brackets Set
20LC...	A20LCKM□**

Complete Set Unassembled Chain type	End Brackets Set
20LC...	A20CLK

** 1=Pos.1; 2=Pos.2; 3=Pos.3

20LC Zinc plated steel chain with aluminium covers

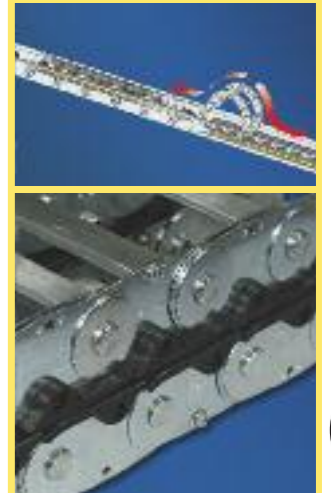

Suitable to long travel distance. See page 220

30LT

Bright Zinc Plated Steel Cable Chains

Inner height (D) 52 mm

Zinc coated ultra-high-strength steel cable chain.
Available with aluminium frames (LT) or with aluminium holed cross-pieces (LA) mounted each second link.
Full-links frames assembling available on demand.
Inner width C can be required at the needed size.
Stainless steel 316L available on demand.

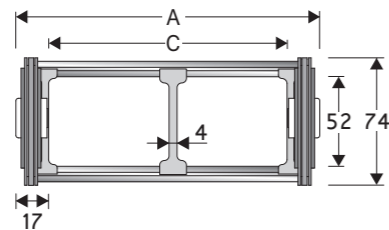

Separator

- Unassembled Part.no. S308CO
- Assembled Part.no. S308COMC

Aluminium frames with nylon separators

A	B	C	D	R	Weight/m	Chain
mm	mm	mm	mm	mm	kg	Part Number
140	74	106	52	150-220-250-305-400-535	6,20	30LT106□□□*
190	74	156	52	150-220-250-305-400-535	6,44	30LT156□□□*
240	74	206	52	150-220-250-305-400-535	6,68	30LT206□□□*
290	74	256	52	150-220-250-305-400-535	6,92	30LT256□□□*
340	74	306	52	150-220-250-305-400-535	7,16	30LT306□□□*
390	74	356	52	150-220-250-305-400-535	7,40	30LT356□□□*
440	74	406	52	150-220-250-305-400-535	7,65	30LT406□□□*
490	74	456	52	150-220-250-305-400-535	7,89	30LT456□□□*
540	74	506	52	150-220-250-305-400-535	8,13	30LT506□□□*
C+34	74	52	150-220-250-305-400-535		30LT□□□□□**

Complete the code by inserting the value of the radius (R): Ex. 30LT156□□□

**Complete the code by inserting the value of the quote C and the radius (R): Ex. 30LT□□□□□*

Chain equipped with aluminium draw plates every pitch: complete the code by inserting the letter D. Ex. 30LT156250□

Machined Cross Frame

Machined cross frames 30LA available on request for bending radius listed below. Custom solutions for machined cross frames realization, based on customer's and/or specific requirements. Please contact Brevetti Stendalto's Technical Department for further information.

R	H*	N	M	N1	M1
mm	mm	mm	mm	mm	mm
150	388	290	670	830	1770
220	528	360	890	1145	2515
250	588	385	980	1255	2800
305	698	440	1150	1450	3285
400	888	540	1450	1740	4065
535	1158	675	1880	2110	5105

*The height H should be increased by 10 mm/m approx. because of preload. In case of limitation to the available space, refer to the Technical Dptm.

Self-Supporting Capacity Diagram

The maximum length of the self-supporting capacity ($\frac{LS}{2}$) in relationship to the weight of the cables and hoses contained per linear metre.

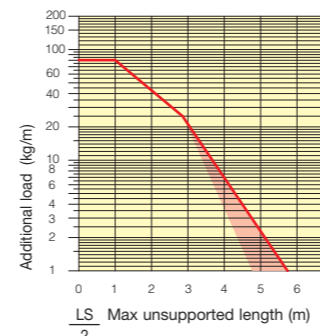

Bright Zinc Plated Steel End Brackets

The end brackets set, containing four steel plates screwed to the links allows the two ends of the chain to be attached to the equipment.

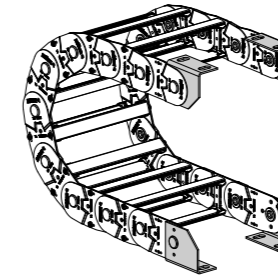
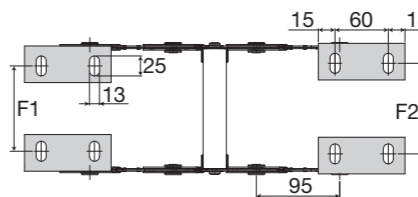
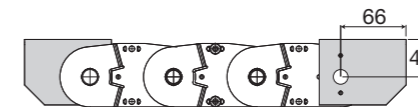

Fig. A Chain fixed outer radius. (Fig A)



Chain Type	F1 mm	F2 mm
30LT106	77	83
30LT156	127	133
30LT206	177	183
30LT256	227	233
30LT306	277	283
30LT356	327	333
30LT406	377	383
30LT456	427	433
30LT506	477	483

Special widths
F1=A-63 F2=A-57

Bright Zinc Plated Steel Type Part Numbers

Complete Set Assembled Chain Type	End Brackets Set
30LT...	A30LKM□**

Complete Set Unassembled Chain Type	End Brackets Set
30LT...	A30LK

** 1=Pos.1; 2=Pos.2; 3=Pos.3

30LT Bright Zinc Plated Steel Cable Chains



Suitable to long travel distance. See page 221

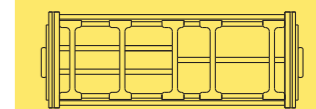

Supplementary movable separators.

For further information please consult Brevetti Stendalto's Technical Office.

Length of chain (L)
Half travel distance ($\frac{LS}{2}$)
plus length of curve (M) or (M1)

$$L = \frac{LS}{2} + M \text{ or } M1$$



30LC

Bright zinc plated steel cable chain with aluminium covers

Inner height (D) 52 mm

Bright Zinc Plated Steel Cable Chain with aluminium cover and the quote C can be in special size. Available it can be done in Stainless steel.

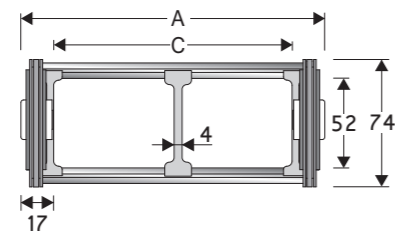

Separator

- Unassembled Part.no S308CO
- Assembled Part.no S308COMC

Technical characteristics

Speed	0,5 m/s
Acceleration	2 m/s ²

For higher requirements please consult our technical dept.

For sliding applications, characteristics techniques may vary depending on the frequency, added weight and work environment.

Aluminium frames with nylon separators

A	B	C	D	R	Weight/m	Chain
mm	mm	mm	mm	mm	kg	Part Number
140	74	106	52	150-220-250-305-400-535	7,96	30LC106□□□*
190	74	156	52	150-220-250-305-400-535	8,87	30LC156□□□*
240	74	206	52	150-220-250-305-400-535	9,79	30LC206□□□*
290	74	256	52	150-220-250-305-400-535	10,70	30LC256□□□*
340	74	306	52	150-220-250-305-400-535	11,61	30LC306□□□*
390	74	356	52	150-220-250-305-400-535	12,53	30LC356□□□*
440	74	406	52	150-220-250-305-400-535	13,44	30LC406□□□*
490	74	456	52	150-220-250-305-400-535	14,36	30LC456□□□*
540	74	506	52	150-220-250-305-400-535	15,27	30LC506□□□*
C+34	74	52	150-220-250-305-400-535		30LC□□□□□**

Complete the code by inserting the value of the radius (R): Ex. 30LC156□□□

Complete the code by inserting the value of the quote C and the radius (R): Ex. 30LC□□□□□

R	H*	N	M	N1	M1
mm	mm	mm	mm	mm	mm
150	388	290	670	830	1770
220	528	360	890	1145	2515
250	588	385	980	1255	2800
305	698	440	1150	1450	3285
400	888	540	1450	1740	4065
535	1158	675	1880	2110	5105

*The height H should be increased by 10 mm/m approx. because of preload. In case of limitation to the available space, refer to the Technical Dptm.

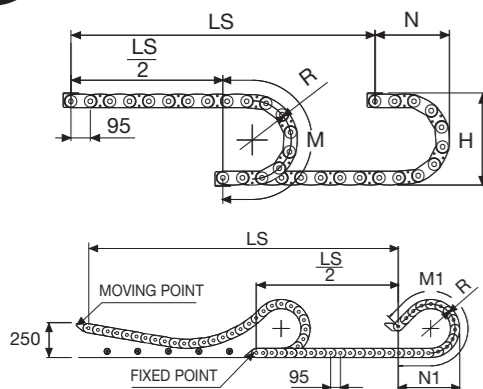

Self-Supporting Capacity Diagram

The maximum length of the self-supporting capacity ($\frac{LS}{2}$) in relationship to the weight of the cables and hoses contained per linear metre.

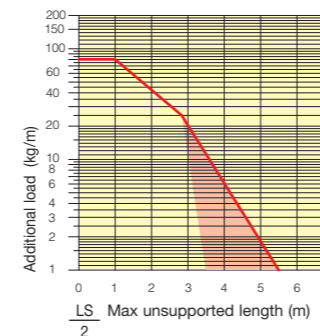

Bright Zinc Plated Steel End Brackets

The end brackets set, containing four steel plates screwed to the links allows the two ends of the chain to be attached to the equipment.

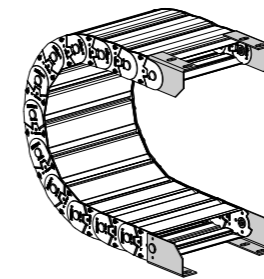
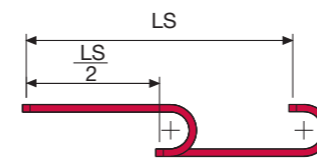
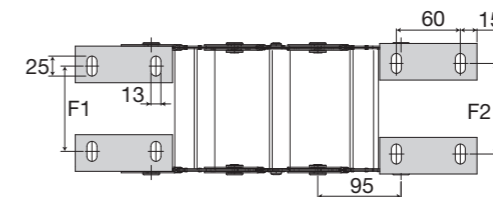

Fig. A Chain fixed outer radius. (Fig A)



The red marking in the diagram area considers the difference of weight between various widths of chain.

For applications with $\frac{LS}{2}$ and weights not included in the area of the diagram showing self-supporting capacity, verify the possible use of support rollers (see page 30).

Chain Type	F1 mm	F2 mm
30LC106	77	83
30LC156	127	133
30LC206	177	183
30LC256	227	233
30LC306	277	283
30LC356	327	333
30LC406	377	383
30LC456	427	433
30LC506	477	483

Special widths
F1=A-63 F2=A-57

Bright Zinc Plated Steel Type Part Numbers

Complete Set Assembled	End Brackets
Chain	Set
30LC...	A30LCKM□**

Complete Set Unassembled	End Brackets
Chain	Set
30LC...	A30LCK

** 1=Pos.1; 2=Pos.2; 3=Pos.3

30LC

Bright zinc plated steel cable chain with aluminium covers

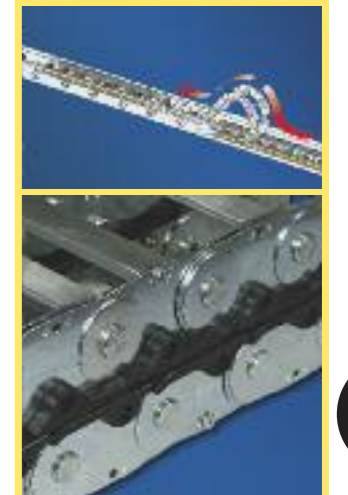

Suitable to long travel distance. See page 221

35LT

Bright zinc plated steel cable chain with Alu-frames

Inner height (D) 65 mm

Bright Zinc Plated Steel Cable Chain.¹ Aluminium Holed cross pieces designed or Alu-frame are mounted each second link. Quote C can be in special size.

⁽¹⁾ available in Stainless Steel.

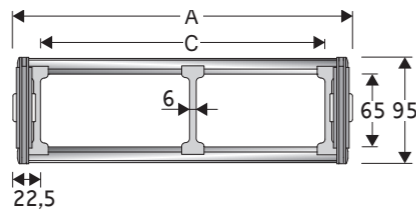

Separator

- Unassembled	Part.no	ST3500F
- Assembled	Part.no	ST3500FMC

Technical characteristics when self-supported

Speed	0,5 m/s
Acceleration	2 m/s ²

For higher requirements please consult our technical dept.

Aluminium frames with nylon separators

A	B	C	D	R	Weight/m	Chain
mm	mm	mm	mm	mm	kg	Part Number
149	95	104	65	200-250-300-350-400-450-500-600	10,30	35LT104□□□*
199	95	154	65	200-250-300-350-400-450-500-600	10,67	35LT154□□□*
249	95	204	65	200-250-300-350-400-450-500-600	11,04	35LT204□□□*
299	95	254	65	200-250-300-350-400-450-500-600	11,41	35LT254□□□*
349	95	304	65	200-250-300-350-400-450-500-600	11,78	35LT304□□□*
399	95	354	65	200-250-300-350-400-450-500-600	12,15	35LT354□□□*
449	95	404	65	200-250-300-350-400-450-500-600	12,52	35LT404□□□*
499	95	454	65	200-250-300-350-400-450-500-600	12,89	35LT454□□□*
549	95	504	65	200-250-300-350-400-450-500-600	13,26	35LT504□□□*
C+45	95	65	200-250-300-350-400-450-500-600		35LT□□□□□**

Complete the code by inserting the value of the radius (R): Ex. 35LT154□□□

**Complete the code by inserting the value of the quote C and the radius (R): Ex. 35LT□□□□□*

Chain equipped with aluminium draw plates every pitch: complete the code by inserting the letter D. Ex. 35LT154250□

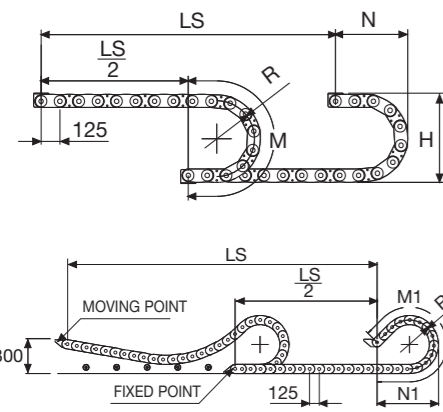

Length of chain (L)

Half travel distance ($\frac{LS}{2}$)

plus length of curve (M) or (M1)

$$L = \frac{LS}{2} + M \text{ or } M1$$

Machined Cross Frame

Machined cross frames 35LA available on request for bending radius listed below. Custom solutions for machined cross frames realization, based on customer's and/or specific requirements. Please contact Brevetti Stendalto's Technical Department for further information.

R	H*	N	M	N1	M1
mm	mm	mm	mm	mm	mm
200	512	375	880	1100	2360
250	612	425	1040	1310	2870
300	712	480	1200	1495	3335
350	812	525	1350	1670	3775
400	912	575	1510	1825	4190
450	1012	625	1670	1975	4595
500	1112	675	1825	2120	4985
600	1312	775	2140	2390	5750

*The height H should be increased by 10 mm/m approx. because of preload. In case of limitation to the available space, refer to the Technical Dptm.

Self-Supporting Capacity Diagram

The maximum length of the self-supporting capacity ($\frac{LS}{2}$) in relationship to the weight of the cables and hoses contained per linear metre.

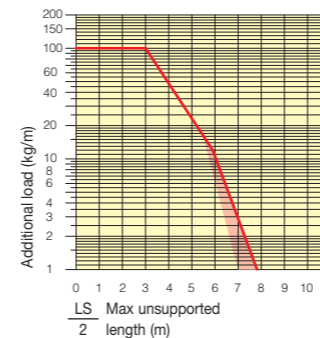

Bright Zinc Plated Steel End Brackets

The end brackets set, containing four steel plates screwed to the links allows the two ends of the chain to be attached to the equipment.

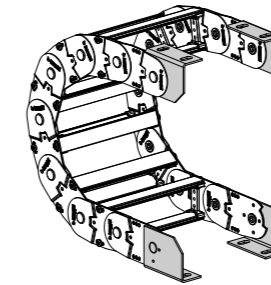
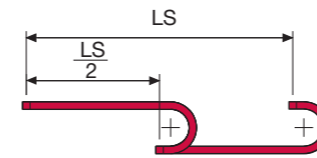
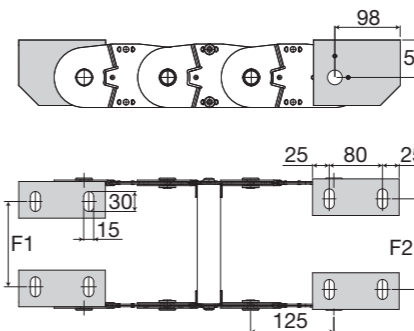

Fig. A Chain fixed outer radius (Fig A)



The red marking in the diagram area considers the difference of weight between various widths of chain.

For applications with $\frac{LS}{2}$ and weights not included in the area of the diagram showing self-supporting capacity, verify the possible use of support rollers (see page 30).

Chain type	F1	F2
	mm	mm
35LT104	78	86
35LT154	128	136
35LT204	178	186
35LT254	228	236
35LT304	278	286
35LT354	328	336
35LT404	378	386
35LT454	428	436
35LT504	478	486

Special widths
F1=A-71,5 F2=A-63,5

Bright Zinc Plated Steel Type Part Numbers

Complete Set Assembled	End Brackets
Chain type	Set
35LT...	A35LKM□**

Complete Set Unassembled	End Brackets
Chain type	Set
35LT...	A35LK

** 1=Pos.1; 2=Pos.2; 3=Pos.3

35LT Bright zinc plated steel cable chain with Alu-frames



Suitable to long travel distance See page 222

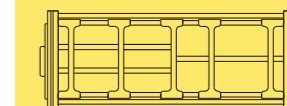

Supplementary movable separators.

For further information please consult Brevetti Stendalto's Technical Office

35LC

Stainless steel cable chain with the aluminium covers

Inner height (D) 65 mm

Bright Zinc Plated Steel Cable Chain with aluminium cover and the quote C can be in special size. Available it can be done in Stainless steel.

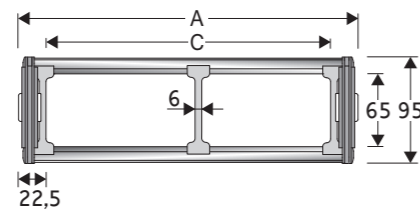

Separator

- Unassembled	Part.no	ST3500F
- Assembled	Part.no	ST3500FMC

Technical characteristics when self-supported

Speed	0,5 m/s
Acceleration	2 m/s ²

For higher requirements please consult our technical dept.

For sliding applications, characteristics techniques may vary depending on the frequency, added weight and work environment.

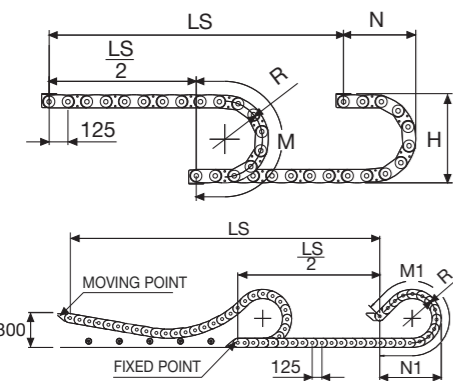

Length of chain (L)
Half travel distance ($\frac{LS}{2}$)
plus length of curve (M) or (M1)

$$L = \frac{LS}{2} + M \text{ or } M1$$

Aluminium frames with nylon separators

A	B	C	D	R	Weight/m	Chain
mm	mm	mm	mm	mm	kg	Part Number
149	95	104	65	200-250-300-350-400-450-500-600	12,20	35LC104□□□*
199	95	154	65	200-250-300-350-400-450-500-600	13,23	35LC154□□□*
249	95	204	65	200-250-300-350-400-450-500-600	14,26	35LC204□□□*
299	95	254	65	200-250-300-350-400-450-500-600	15,29	35LC254□□□*
349	95	304	65	200-250-300-350-400-450-500-600	16,32	35LC304□□□*
399	95	354	65	200-250-300-350-400-450-500-600	17,35	35LC354□□□*
449	95	404	65	200-250-300-350-400-450-500-600	18,37	35LC404□□□*
499	95	454	65	200-250-300-350-400-450-500-600	19,40	35LC454□□□*
549	95	504	65	200-250-300-350-400-450-500-600	20,43	35LC504□□□*
C+45	95	65	200-250-300-350-400-450-500-600		35LC□□□□□**

*Complete the code by inserting the value of the radius (R): Ex. 35LC154□□□□

**Complete the code by inserting the value of the quote C and the radius (R): Ex. 35LC□□□□□□□□

R	H*	N	M	N1	M1
mm	mm	mm	mm	mm	mm
200	512	375	880	1100	2360
250	612	425	1040	1310	2870
300	712	480	1200	1495	3335
350	812	525	1350	1670	3775
400	912	575	1510	1825	4190
450	1012	625	1670	1975	4595
500	1112	675	1825	2120	4985
600	1312	775	2140	2390	5750

*The height H should be increased by 10 mm/m approx. because of preload. In case of limitation to the available space, refer to the Technical Dptm.

Self-Supporting Capacity Diagram

The maximum length of the self-supporting capacity ($\frac{LS}{2}$) in relationship to the weight of the cables and hoses contained per linear metre.

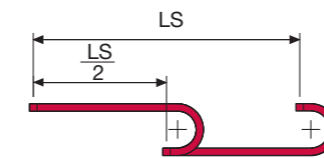
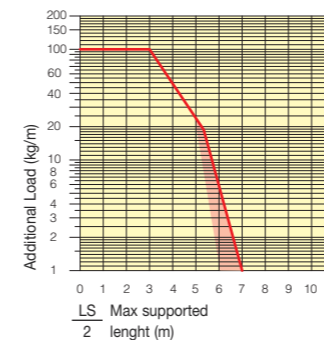

The red marking in the diagram area considers the difference of weight between various widths of chain.

For applications with $\frac{LS}{2}$ and weights not included in the area of the diagram showing self-supporting capacity, verify the possible use of support rollers (see page 30).

Bright Zinc Plated Steel End Brackets

The end brackets set, containing four steel plates screwed to the links allows the two ends of the chain to be attached to the equipment.

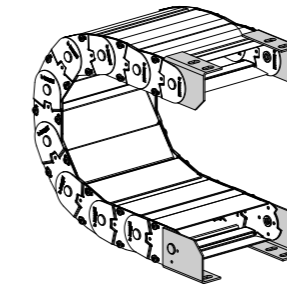
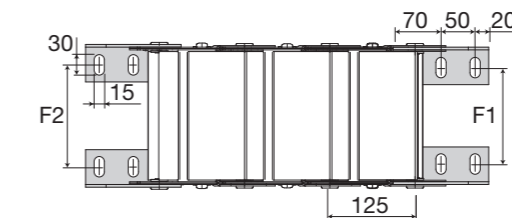
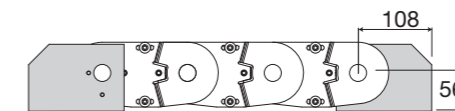

Fig. A Chain fixed outer radius (Fig A)



Chain Type	F1 mm	F2 mm
35LC104	78	86
35LC154	128	136
35LC204	178	186
35LC254	228	236
35LC304	278	286
35LC354	328	336
35LC404	378	386
35LC454	428	436
35LC504	478	486
Special widths		
F1=A-71,5	F2=A-63,5	

Bright Zinc Plated Steel Type Part Numbers

Chain type	End Brackets Set
35LC...	A35LCKM□□**

Chain type	End Brackets Set
35LC...	A35LCK

** 1=Pos.1; 2=Pos.2; 3=Pos.3

35LC Stainless steel cable chain with the aluminium covers

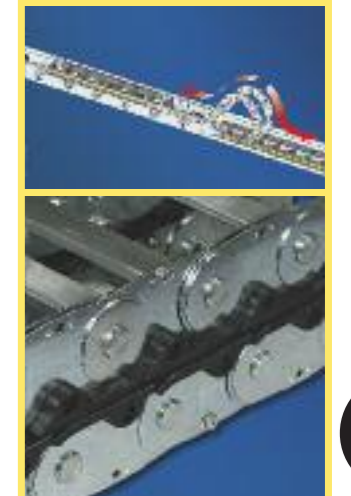

Suitable to long travel distance See page 223

40LT

Bright zinc plated steel cable chain with Alu-frames

Inner height (D) 112,5 mm
Bright Zinc Plated Steel Cable Chain.¹
Aluminium Holed cross pieces designed or Alu-frame are mounted each every link. Quote C can be in special quote.
⁽¹⁾ available in Stainless Steel.

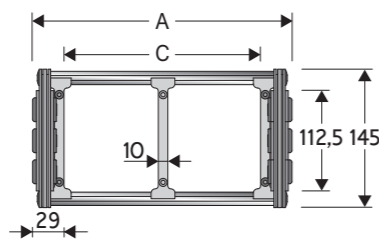

Separator	
- Unassembled	Part.no S310TCF9
- Assembled	Part.no S310TCF9MC

Technical characteristics when self-supported

Speed	0,5 m/s
Acceleration	2 m/s ²

For higher requirements please consult our technical dept.

For sliding applications, characteristics techniques may vary depending on the frequency, added weight and work environment.

Aluminium frames with nylon separators

A	B	C	D	R	Weight/m	Chain
mm	mm	mm	mm	mm	kg	Part Number
208	145	150	112,5	250-300-350-400-450-500-550-600-700-750-850	19,30	40LT150 □□□ *
258	145	200	112,5	250-300-350-400-450-500-550-600-700-750-850	19,76	40LT200 □□□ *
308	145	250	112,5	250-300-350-400-450-500-550-600-700-750-850	20,22	40LT250 □□□ *
358	145	300	112,5	250-300-350-400-450-500-550-600-700-750-850	20,68	40LT300 □□□ *
458	145	400	112,5	250-300-350-400-450-500-550-600-700-750-850	21,61	40LT400 □□□ *
558	145	500	112,5	250-300-350-400-450-500-550-600-700-750-850	22,53	40LT500 □□□ *
C+58	145	112,5	250-300-350-400-450-500-550-600-700-750-850		40LT □□□□□ **

*Complete the code by inserting the value of the radius (R): Ex. 40LT150 □ □ □ □

**Complete the code by inserting the value of the quote C and the radius (R): Ex. 40LT □ □ □ □ □ □ □ □

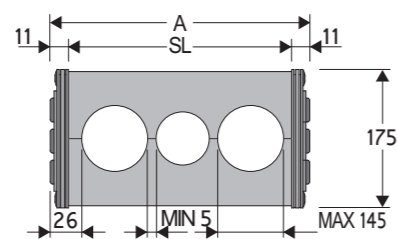
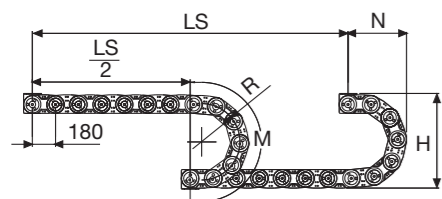

R	H*	N	M	N1	M1
mm	mm	mm	mm	mm	mm
250	664	510	1150	1545	3285
300	764	555	1305	1755	3790
350	864	605	1460	1950	4265
400	964	655	1620	2125	4715
450	1064	710	1780	2295	5150
500	1164	755	1930	2455	5570
550	1264	805	2090	2605	5975
600	1364	855	2245	2755	6375
700	1564	955	2560	3035	7155
750	1664	1010	2720	3170	7535
850	1864	1105	3030	3430	8280
1000	2164	1255	3500	-	-

* The height H should be increased by 10 mm/m approx. because of preload. In case of limitation to available space, refer to the Technical Deptm.

Machined Cross Frame

Machined cross frames 40LA available on request for bending radius listed below. Custom solutions for machined cross frames realization, based on customer's and/or specific requirements.

Please contact Brevetti Stendalto's Technical Department for further information.

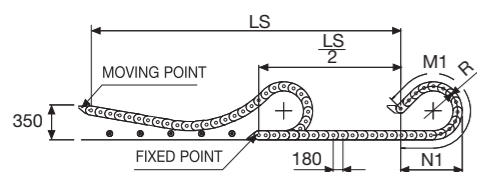

Length of chain (L)
Half travel distance ($\frac{LS}{2}$)
plus length of curve (M) or (M1)
 $L = \frac{LS}{2} + M$ or $M1$

Self-Supporting Capacity Diagram

The maximum length of the self-supporting capacity ($\frac{LS}{2}$) in relationship to the weight of the cables and hoses contained per linear metre.

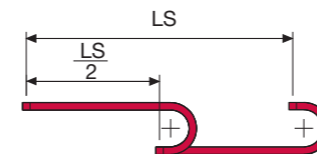
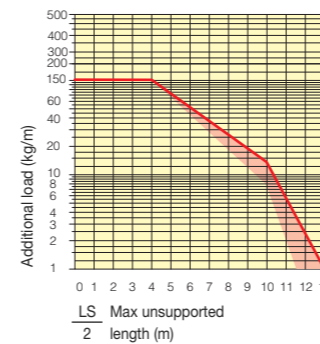

The red marking in the diagram area considers the difference of weight between various widths of chain.

For applications with $\frac{LS}{2}$ and weights not included in the area of the diagram showing self-supporting capacity, verify the possible use of support rollers (see page 30).

Bright Zinc Plated Steel End Brackets

The end brackets set, containing four steel plates screwed to the links allows the two ends of the chain to be attached to the equipment.

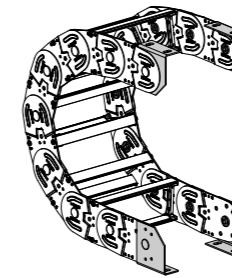
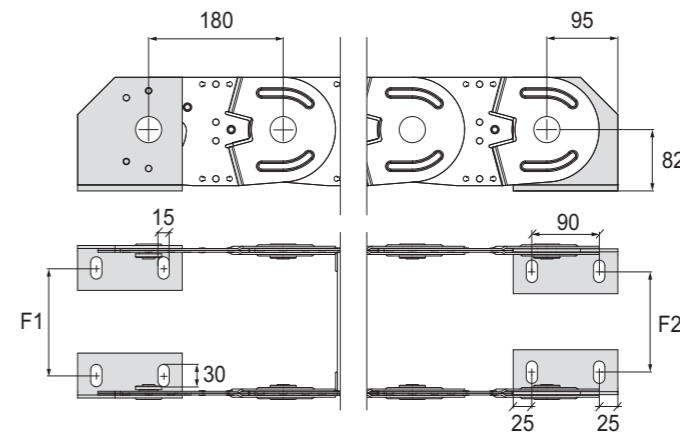

Fig. A
Chain fixed outer radius (Fig A)
See mounting variations page 31



Chain type	F1 mm	Chain type	F2 mm
40LT150	135	40LT150	144
40LT200	185	40LT200	194
40LT250	235	40LT250	244
40LT300	285	40LT300	294
40LT400	385	40LT400	394
40LT500	485	40LT500	494
Special Widths	F=A-73	Special Widths	F=A-64

Bright Zinc Plated Steel Type Part Numbers

Chain type	End Brackets Set
40...	A40LKM □ **

Chain type	End Brackets Set
40...	A40LK

** 1=Pos.1; 2=Pos.2; 3=Pos.3

See mounting variations page 31

40LT

Bright zinc plated steel cable chain with Alu-frame



Suitable to long travel distance
See page 223



Supplementary movable separators

For further information please consult Brevetti Stendalto's Technical Office

40LC Zinc plated steel chain with aluminium cover

Inner height (D) 104,5 mm

Bright Zinc Plated Steel Cable Chain with aluminium cover and the quote C can be in special size. Available it can be done in Stainless steel.

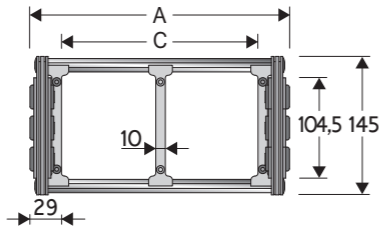

Separator

- Unassembled	Part.no S310TCF9
- Assembled	Part.no S310TCF9MC

Technical characteristics when self-supported

Speed	0,5 m/s
Acceleration	2 m/s ²

For higher requirements please consult our technical dept.

Aluminium Draw Plates with nylon separators

A	B	C	D	R	Weight/m	Chain
mm	mm	mm	mm	mm	kg	Part Number
208	145	150	104,5	250-300-350-400-450-500-550-600-700-750-850	22,47	40LC150 □□□ *
258	145	200	104,5	250-300-350-400-450-500-550-600-700-750-850	23,84	40LC200 □□□ *
308	145	250	104,5	250-300-350-400-450-500-550-600-700-750-850	25,20	40LC250 □□□ *
358	145	300	104,5	250-300-350-400-450-500-550-600-700-750-850	26,56	40LC300 □□□ *
458	145	400	104,5	250-300-350-400-450-500-550-600-700-750-850	29,28	40LC400 □□□ *
558	145	500	104,5	250-300-350-400-450-500-550-600-700-750-850	31,01	40LC500 □□□ *
C+58	145	104,5	250-300-350-400-450-500-550-600-700-750-850		40LC □□□□□ **

*Complete the code by inserting the value of the radius (R): Ex. 40LC150 □□□ □□ □□

**Complete the code by inserting the value of the quote C and the radius (R): Ex. 40LC □□ □□ □□ □□ □□

R	H*	N	M	N1	M1
mm	mm	mm	mm	mm	mm
250	650	510	1150	1545	3285
300	750	555	1305	1755	3790
350	850	605	1460	1950	4265
400	950	655	1620	2125	4715
450	1050	710	1780	2295	5150
500	1150	755	1930	2455	5570
550	1250	805	2090	2605	5975
600	1350	855	2245	2755	6375
700	1550	955	2560	3035	7155
750	1650	1010	2720	3170	7535
850	1850	1105	3030	3430	8280
1000	2150	1255	3500	-	-

* The height H should be increased by 10 mm/m approx. because of preload. In case of limitation to the available space, refer to the Technical Dept.

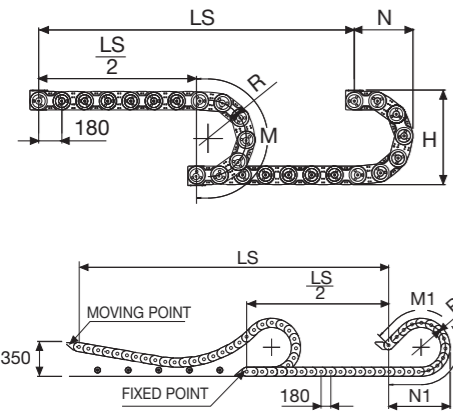

Length of chain (L)

Half travel distance ($\frac{LS}{2}$)

plus length of curve (M) or (M1)

$$L = \frac{LS}{2} + M \text{ or } M1$$

Self-Supporting Capacity Diagram

The maximum length of the self-supporting capacity ($\frac{LS}{2}$) in relationship to the weight of the cables and hoses contained per linear metre.

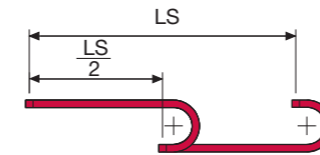
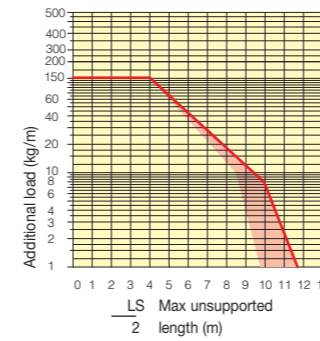

The red marking in the diagram area considers the difference of weight between various widths of chain.

For applications with $\frac{LS}{2}$ and weights not included in the area of the diagram showing self-supporting capacity, verify the possible use of support rollers (see page 30).

Bright Zinc Plated Steel End Brackets

The end brackets set, containing four steel plates screwed to the links allows the two ends of the chain to be attached to the equipment.

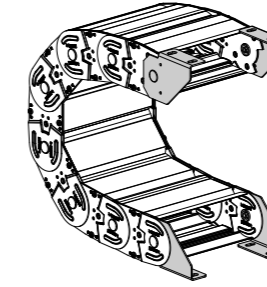
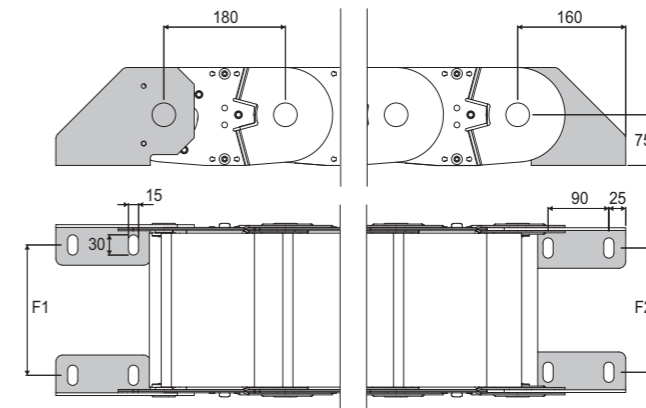

Fig. A
Chain fixed outer radius (Fig A)
See mounting variations page 31



Chain type	F1 mm	F2 mm
40LC150	144	135
40LC200	194	185
40LC250	244	235
40LC300	294	285
40LC400	394	385
40LC500	494	485

Special Widths
F1=A-64 F2=A-73

Bright Zinc Plated Steel Type Part Numbers

Complete Set Assembled	End Brackets
Chain Type	Set
40LC	A40LCKM □ *

Complete Set Unassembled	End Brackets
Chain Type	Set
40LC	A40LCK

** 1=Pos.1; 2=Pos.2; 3=Pos.3
Mount Variant page 31

40LC Zinc plated steel chain with aluminium cover



Suitable to long travel distance
See page 233

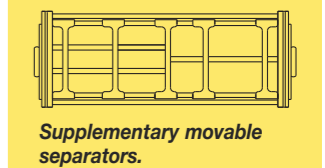

Supplementary movable separators.

For further information please consult Brevetti Stendato's Technical Office

42LT

Bright zinc plated steel cable chain with Alu-frames

Inner height (D) 138 mm

Bright Zinc Plated Steel Cable Chain.¹
Aluminium Holed cross pieces designed or Alu-frame are mounted every link.
Quote C can be in special size.
⁽¹⁾ available in Stainless Steel.

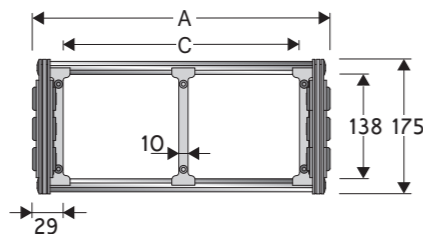

Separator	
- Unassembled	Part.no S42TCF9
- Assembled	Part.no S42TCF9MC

Technical characteristics when self-supported

Speed	0,5 m/s
Acceleration	2 m/s ²

For higher requirements please consult our technical dept.

4 For sliding applications, characteristics techniques may vary depending on the frequency, added weight and work environment.

Aluminium draw plates with nylon separators

A	B	C	D	R	Weight/m	Chain
mm	mm	mm	mm	mm	kg	Part Number
208	175	150	138	250-300-350-400-450-500-550-600-700-750-850	22,84	42LT150 □□□ *
258	175	200	138	250-300-350-400-450-500-550-600-700-750-850	23,30	42LT200 □□□ *
308	175	250	138	250-300-350-400-450-500-550-600-700-750-850	23,76	42LT250 □□□ *
358	175	300	138	250-300-350-400-450-500-550-600-700-750-850	24,22	42LT300 □□□ *
458	175	400	138	250-300-350-400-450-500-550-600-700-750-850	25,15	42LT400 □□□ *
558	175	500	138	250-300-350-400-450-500-550-600-700-750-850	26,07	42LT500 □□□ *
C+58	175	138	250-300-350-400-450-500-550-600-700-750-850		42LT □□□□□ **

*Complete the code by inserting the value of the radius (R): 42LT150 □□□ □

**Complete the code by inserting the value of the quota C and the radius (R): Es. 42LT □□□□□ □□

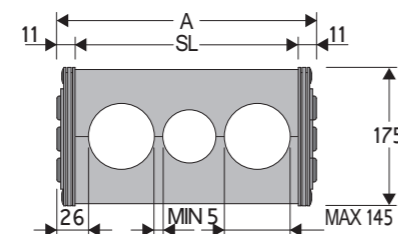

Machined Cross Frame

Machined cross frames (42LA) available on request for bending radius listed below. Custom solutions for machined cross frames realization, based on customer's and/or specific requirements. Please contact Brevetti Stendalto's Technical Department for further information.

R	H*	N	M	N1	M1
mm	mm	mm	mm	mm	mm
250	720	510	1150	1545	3285
300	820	555	1305	1755	3790
350	920	605	1460	1950	4265
400	1020	655	1620	2125	4715
450	1120	710	1780	2295	5150
500	1220	755	1930	2455	5570
550	1320	805	2090	2605	5975
600	1420	855	2245	2755	6375
700	1620	955	2560	3035	7155
750	1720	1010	2720	3170	7535
850	1920	1105	3030	3430	8280
1000	2220	1255	3500	-	-

*The height H should be increased by 10 mm/m approx. because of preload. In case of limitation to the available space, refer to the Technical Dptm.

Self-Supporting Capacity Diagram

The maximum length of the self-supporting capacity ($\frac{LS}{2}$) in relationship to the weight of the cables and hoses contained per linear metre.

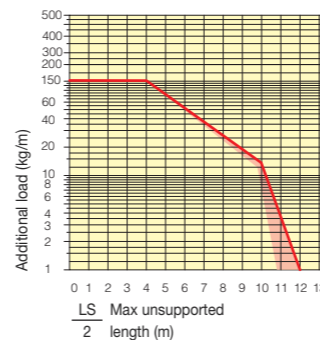

Bright Zinc Plated Steel End Brackets

The end brackets set, containing four steel plates screwed to the links allows the two ends of the chain to be attached to the equipment.

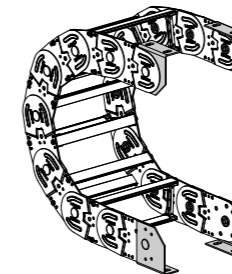
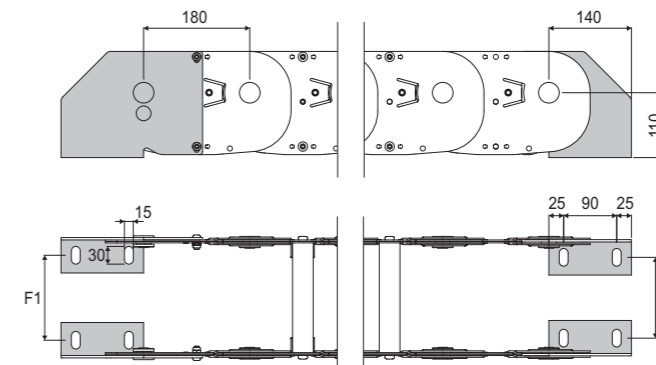

Fig. A Chain fixed outer radius (Fig A). See mounting variations page 31



Chain Type	F1 mm	Chain type	F2 mm
42LT150	144	42LT150	135
42LT200	194	42LT200	185
42LT250	244	42LT250	235
42LT300	294	42LT300	285
42LT400	394	42LT400	385
42LT500	494	42LT500	485
Special Widths	F=A-64	Special Widths	F=A-73

Bright Zinc Plated Steel Type Part Numbers

Complete Set Assembled	
Chain type	End Brackets Set
42LT...	A42LKM □ **

Complete Set Unassembled	
Chain type	End Brackets Set
42LT...	A42LK

** 1=Pos.1; 2=Pos.2; 3=Pos.3

See mounting variations page 31

42LT Bright zinc plated steel cable chain with Alu-frames



Suitable to long travel distance See page 220

45T

Cable Chains in Bright Zinc Plated Steel

Inner height (D) 182 mm

Double share link construction. Triple-rivet fixing and standard large washer and nylon anti-friction disk to assure smooth and durable movement. Un-screwable Alu-draw frames (T) are standard mounted every link. Alu-drilled plates (TL) are mounted every second link with an Alu-draw frames every other link. Separator systems available. Also available in Stainless Steel.

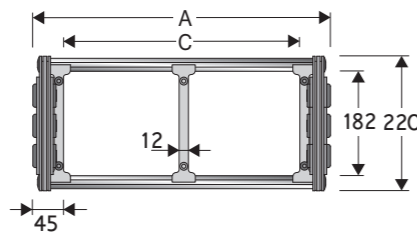

Separator

- Unassembled	Part.no ST4500F1C
- Assembled	Part.no ST4500F1CMC

Aluminium Draw Plates with Separators in Nylon

A	B	C	D	R	Weight/m	Chain
mm	mm	mm	mm	mm	kg	Part Number
390	220	300	182	400-600-800-1000-1250-1500	40,97	45T300 □□□ *
440	220	350	182	400-600-800-1000-1250-1500	41,31	45T350 □□□ *
490	220	400	182	400-600-800-1000-1250-1500	41,64	45T400 □□□ *
540	220	450	182	400-600-800-1000-1250-1500	41,97	45T450 □□□ *
590	220	500	182	400-600-800-1000-1250-1500	42,30	45T500 □□□ *
690	220	600	182	400-600-800-1000-1250-1500	42,97	45T600 □□□ *
C+90	220	182	400-600-800-1000-1250-1500		45T □□□□□ **

*Complete the code by inserting the value of the radius (R): Ex. 45T300 □ □ □ □

**Complete the code by inserting the value of the quote C and the radius (R): Ex. 45T □ □ □ □ □ □ □ □

Technical characteristics when self-supported

Speed	0,5 m/s
Acceleration	2 m/s ²

For higher requirements please consult our technical dept.

4

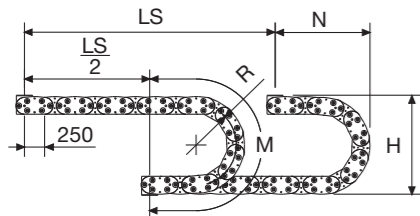

Length of chain (L)

Half travel distance ($\frac{LS}{2}$) plus length of curve (M)

$$L = \frac{LS}{2} + M$$

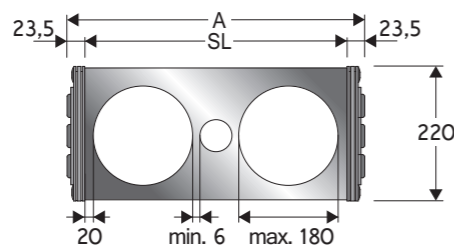

Machined Cross Frame

Machined cross frames (45LT) available on request for bending radius listed below. Custom solutions for machined cross frames realization, based on customer's and/or specific requirements.

Please contact Brevetti Stendalto's Technical Department for further information.

R	H*	N	M
mm	mm	mm	mm
400	1060	770	1760
600	1460	970	2390
800	1860	1170	3020
1000	2260	1370	3650
1250	2760	1620	4430
1500	3260	1870	5220

* The height H should be increased by 10 mm/m approx. because of preload. In case of limitation to the available space, refer to the Technical Dptm.

Self-Supporting Capacity Diagram

The maximum length of the self-supporting capacity ($\frac{LS}{2}$) in relationship to the weight of the cables and hoses contained per linear metre.

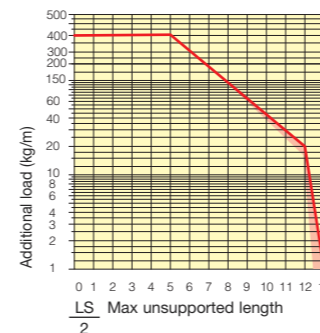

Bright Zinc Plated Steel End Brackets

The end brackets set, containing four steel plates screwed to the links allows the two ends of the chain to be attached to the equipment.

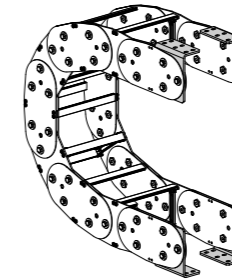
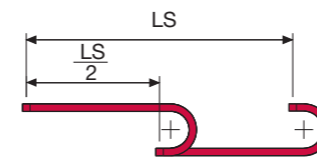
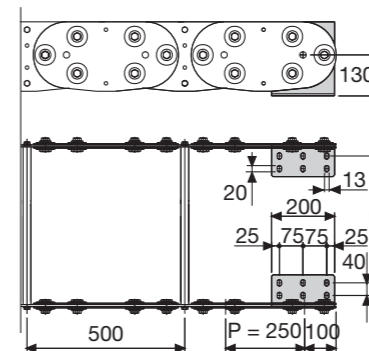

Fig. A Chain fixed outside the radius. (Fig A) See end brackets mounting variations page 31.



The red marking in the diagram area considers the difference of weight between various widths of chains assembled with aluminium draw plates every second pitch.

For applications with $\frac{LS}{2}$ and weights not included in the area of the diagram showing self-supporting capacity, verify the possible use of support rollers (see page 30).



Chain Type	F mm
45T300	285
45T350	335
45T400	385
45T450	435
45T500	485
45T600	585
Special widths F=A-105	

Bright Zinc Plated Steel Type Part Numbers

Complete Set Assembled Chain Type	End Brackets Set
45...	A45KM □ **
Complete Set Unassembled Chain Type	End Brackets Set
45...	A45K

** 1=Pos.1; 2=Pos.2; 3=Pos.3 See end brackets mounting variations page 31.

45T Cable Chain in Bright Zinc Plated Steel

4

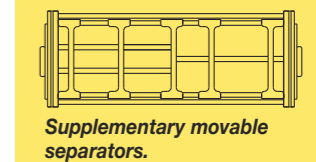

Supplementary movable separators.

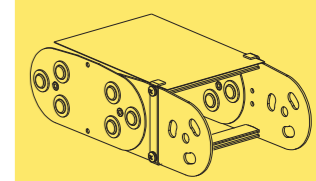

Steel laminar cover.

For further information please consult Brevetti Stendalto's Technical Office

Sliding cable chains in bright zinc plated steel



Sliding low-friction skirts fastened to the links allow chains running on themselves, all the while granting them to get more longer strokes. Aluminium Draw Plates with nylon separations or aluminium split cross piece created by design. Separators system available.

⁽¹⁾ Available in Stainless steel

Technical characteristics when self-supported

Speed	2 m/s
Acceleration	2 m/s ²

For higher requirements please consult our technical dept.

20LPT with aluminium draw plates

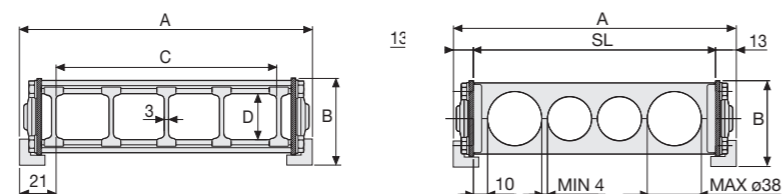

A	B	C	D	R	Weight/m	Chain
mm	mm	mm	mm	mm	kg	Part Number
121	58,5	79	32	115-150-205-250-305	4,82	20LPT079 □□□ *
146	58,5	104	32	115-150-205-250-305	4,97	20LPT104 □□□ *
196	58,5	154	32	115-150-205-250-305	5,27	20LPT154 □□□ *
246	58,5	204	32	115-150-205-250-305	5,57	20LPT204 □□□ *
296	58,5	254	32	115-150-205-250-305	5,87	20LPT254 □□□ *
346	58,5	304	32	115-150-205-250-305	6,17	20LPT304 □□□ *
C+42	58,5	32	115-150-205-250-305		20LPT □□□□□ **

*Complete the code by inserting the value of the radius (R): Ex. 20LPT154 □□□□
 **Complete the code by inserting the value of the quote C and the radius (R): Ex. 20LPT □□□□□□
 Chain equipped with aluminium draw plates every pitch: complete the code by inserting the letter D: Ex. 20LPT154250 □□

Aluminium split cross pieces created by design

A	B	R	Chain
mm	mm	mm	Part Number
SL+26	58,5	115-150-205-250-305	20LPA □□□□□ ***

***Complete the code by inserting the value of the quote SL and the radius (R): Ex. 20LPA □□□□□ □□ □□ □□ □□

20LPC with aluminium covers

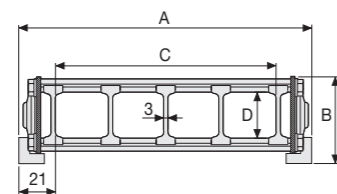

A	B	C	D	R	Weight/m	Chain
mm	mm	mm	mm	mm	kg	Part Number
121	58,5	79	31	115-150-205-250-305	6,59	20LPC079 □□□ *
146	58,5	104	31	115-150-205-250-305	7,08	20LPC104 □□□ *
196	58,5	154	31	115-150-205-250-305	8,05	20LPC154 □□□ *
246	58,5	204	31	115-150-205-250-305	9,02	20LPC204 □□□ *
296	58,5	254	31	115-150-205-250-305	9,99	20LPC254 □□□ *
346	58,5	304	31	115-150-205-250-305	10,96	20LPC304 □□□ *
C+42	58,5	31	115-150-205-250-305		20LPC □□□□□ **

*Complete the code by inserting the value of the radius (R): Ex. 20LPC154 □□□□
 **Complete the code by inserting the value of the quote C and the radius (R): Ex. 20LPC □□□□□ □□ □□ □□ □□

30LPT with aluminium draw plates

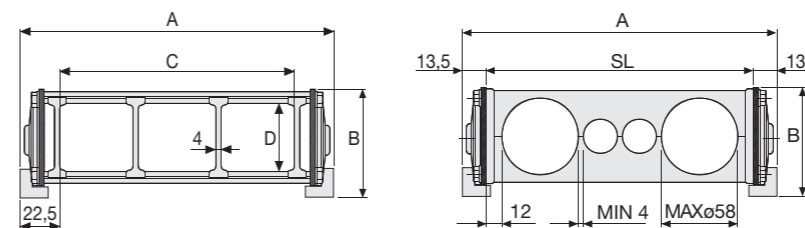

A	B	C	D	R	Weight/m	Chain
mm	mm	mm	mm	mm	kg	Part Number
151	81,5	106	52	150-220-250-305-400-535	6,71	30LPT106 □□□ *
201	81,5	156	52	150-220-250-305-400-535	6,95	30LPT156 □□□ *
251	81,5	206	52	150-220-250-305-400-535	7,20	30LPT206 □□□ *
301	81,5	256	52	150-220-250-305-400-535	7,44	30LPT256 □□□ *
351	81,5	306	52	150-220-250-305-400-535	7,68	30LPT306 □□□ *
401	81,5	356	52	150-220-250-305-400-535	7,92	30LPT356 □□□ *
451	81,5	406	52	150-220-250-305-400-535	8,16	30LPT406 □□□ *
501	81,5	456	52	150-220-250-305-400-535	8,41	30LPT456 □□□ *
551	81,5	506	52	150-220-250-305-400-535	8,65	30LPT506 □□□ *
C+45	81,5	52	150-220-250-305-400-535		30LPT □□□□□ **

*Complete the code by inserting the value of the radius (R): Ex. 30LPT156 □□□□
 **Complete the code by inserting the value of the quote C and the radius (R): Ex. 30LPT □□□□□ □□ □□ □□ □□
 Chain equipped with aluminium draw plates every pitch: complete the code by inserting the letter D: Ex. 30LPT156250 □□

Aluminium split cross pieces created by design

A	B	R	Chain
mm	mm	mm	Part Number
SL+27	81,5	150-220-250-305-400-535	30LPA □□□□□ ***

***Complete the code by inserting the value of the SL and the radius (R): Es. 30LPA □□□□□ □□ □□ □□ □□

30LPC with aluminium covers

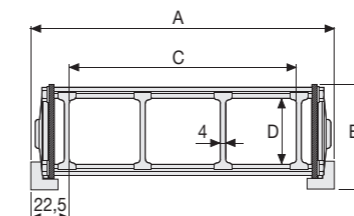

A	B	C	D	R	Weight/m	Chain
mm	mm	mm	mm	mm	kg	Part Number
151	81,5	106	52	150-220-250-305-400-535	8,38	30LPC106 □□□ *
201	81,5	156	52	150-220-250-305-400-535	9,30	30LPC156 □□□ *
251	81,5	206	52	150-220-250-305-400-535	10,21	30LPC206 □□□ *
301	81,5	256	52	150-220-250-305-400-535	11,13	30LPC256 □□□ *
351	81,5	306	52	150-220-250-305-400-535	12,04	30LPC306 □□□ *
401	81,5	356	52	150-220-250-305-400-535	12,95	30LPC356 □□□ *
451	81,5	406	52	150-220-250-305-400-535	13,87	30LPC406 □□□ *
501	81,5	456	52	150-220-250-305-400-535	14,79	30LPC456 □□□ *
551	81,5	506	52	150-220-250-305-400-535	15,70	30LPC506 □□□ *
C+45	81,5	52	150-220-250-305-400-535		30LPC □□□□□ **

*Complete the code by inserting the value of the radius (R): Ex. 30LPC156 □□□□
 **Complete the code by inserting the value of the quote C and the radius (R): Ex. 30LPC □□□□□ □□ □□ □□ □□

For further information please consult Brevetti Stendato's Technical Office

Cable Drag Chains in Steel for Long Travel Distance

The use of cable chains in applications with particularly long travel distances offers many benefits. The possibilities of the combined transportation of high power cables, signal cables and hydraulic hoses, together with ease of use and no need for maintenance, are the unquestionable advantages of the system. Specific applications, characterised by particularly aggressive conditions in the environment, require cable chains in steel. Brevetti Stendalto has offered for many years, with positive results their own system based on the use of two steel drag chains and a travelling internal supporting frame. The chains are arranged in a closed loop configuration, having

a fixed bracket and a movable towing bracket. A secondary similar closed loop, made of steel wire rope, drives the supporting frame along the entire travel at a suitable speed, thus ensuring a continuous support to relieve all stresses. In addition to this a trough is arranged to contain and guide the chain system along the total travel. The chains are fitted with wheels on ball bearings, to keep to a minimum the friction on the supporting frame. The supporting frame can be made both in galvanised steel, or if requested, in stainless steel.

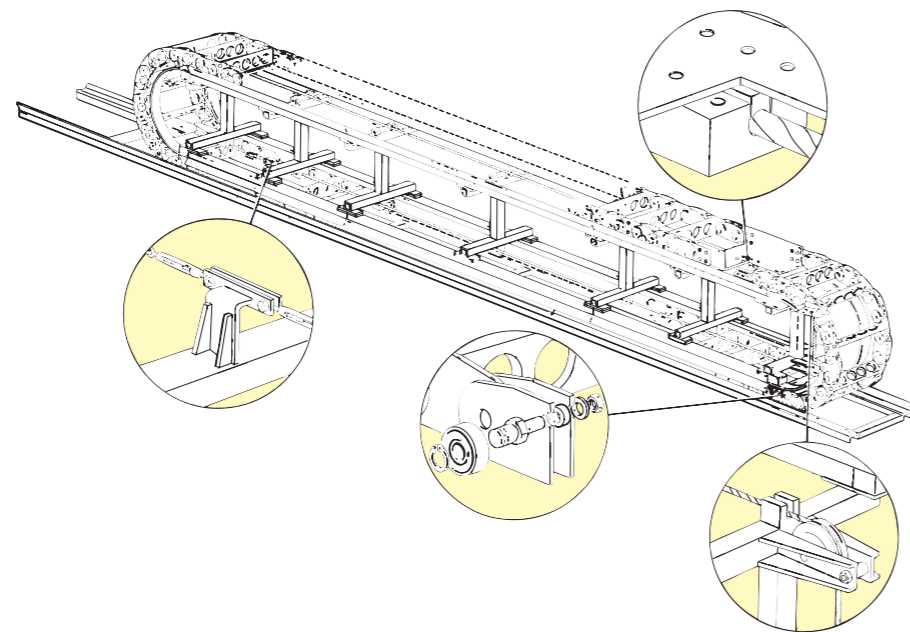

35 chains with supporting frame applied to De Icing equipment at München airport (Germany). The length of the travel distance is 90 m and it's velocity is 90 m per minute.



Special off-shore Applications

The Brevetti Stendalto steel cable chains have been used in Off-shore applications for many years. The high standard of quality required and the special materials needed are characteristics in these kinds of applications.

On request cable chains of special dimensions which have been personalised according to the clients needs are being used.

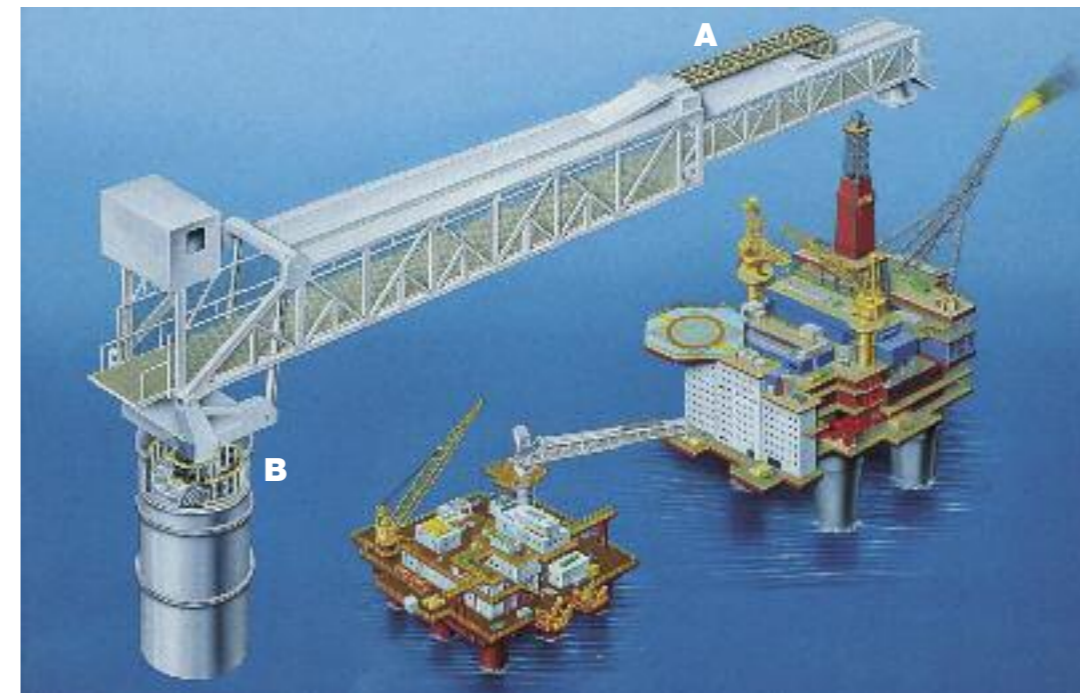

Platform "Oseberg"

A: 45 chain in stainless steel 316L

B: 45 chain in stainless steel 316L for rotations of $\pm 180^\circ$



Platform "Tiffany"

Specially designed chains in stainless steel 316L
Length of travel distance: 27 m
Total weight of the chains: 13 Ton.