

# Serie Robot

## SR545

### Circular Nylon Cable Chain with openable frames

#### Inner height (D) 46 mm

Double share Sideband & Frame construction with large anti-friction single-pin.

Frames openable from inner radius.

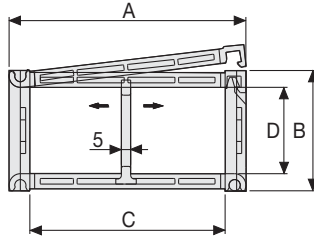

#### Separator

- Unassembled	Part.no S445UF
- Assembled	Part.no S445UFMC

#### Pin

Part.no PG545

#### Technical characteristics

Speed	180°/s
Acceleration	180°/s <sup>2</sup>

For higher requirements please consult our technical dept.

A	B	C	D	R	Weight/pitch	Chain
mm	mm	mm	mm	mm	kg	Part Number
123	62	100	46	100	0,200	SR545SI100100

R	Di	De
mm	mm	mm
100	485	760

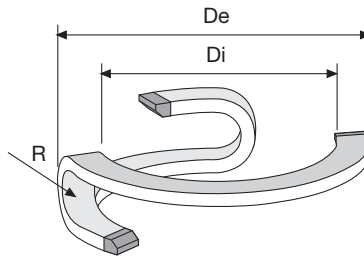

#### Length of Chain

Chain	Degrees	No
Part Numbers	of Rotation	of Pitches
SR545	90	14
SR545	180	18
SR545	270	22
SR545	360	27



## Steel End Brackets

The end brackets set, containing two steel plates screwed to the links, allows the two ends of the chain to be attached to the equipment. The end brackets are installed in one position offering the possibility of attaching the chain externally. (Fig. A)

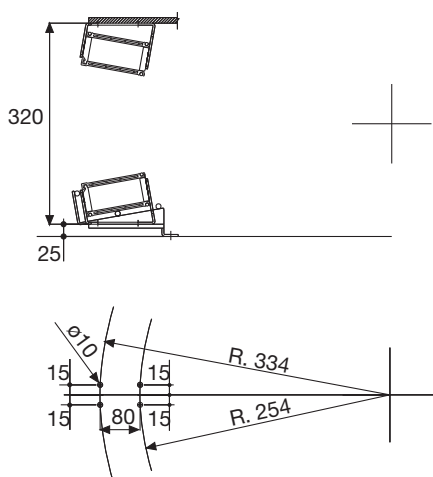

Fig. A

## Support Guide

For correct functioning of the chain it is necessary that the installation is done in a specific position.

For this reason Brevetti Stendalto has observed and created a support guide which can do this. (Fig. B)

For particular applications it is possible to create support guides with attachment plates and special dimensions.

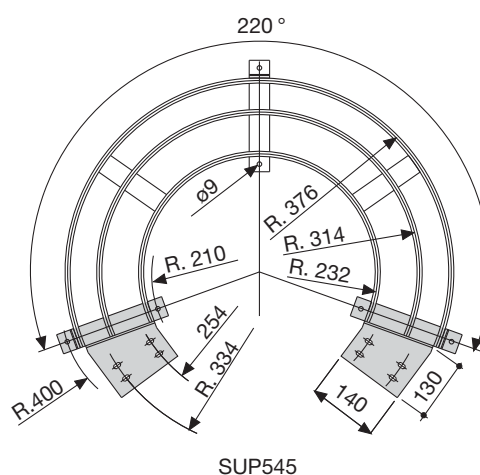

Fig. B

## Steel End Brackets Part Numbers

### Complete Set Assembled

Chain Type	End Brackets Set
SR545	A545KM

### Complete Set Unassembled

Chain Type	End Brackets Set
SR545	A545K

For applications with rotations exceeding 200° it is necessary to use the appropriate accessories for supporting the cable chain. (see page 28).

Serie Robot

## SR545

Circular Nylon Cable Chain  
with openable frames