

Serie Medium

SR355 Nylon Cable Chain

Inner height (D) 30 mm

Double share single link joining construction with large anti-friction single-pin. Non-openable. Vertical separators are available. Due to its design with double-share lateral side, the chain is very robust, meanwhile offering very low friction. Used with guide channels, this chain is particularly suitable for long distance travel.

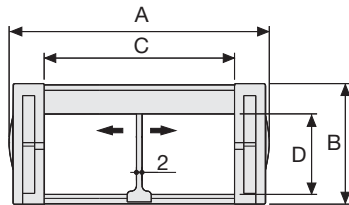

Separator*

- Unassembled	Part.no S355
- Assembled	Part.no S355MC

Pin

Part.no PG355

Technical characteristics when self-supported

Speed	10 m/s
Acceleration	50 m/s ²

For higher requirements please consult our technical dept.

For sliding applications, technical data can slightly change according to frequency, added weight and environment.

*Separator not to be used in long-stroke applications

A	B	C	D	R	Weight/m	Chain
mm	mm	mm	mm	mm	kg	Part Number
74	45	45	30	54	1,35	SR355044
74	45	45	30	75	1,35	SR355045
74	45	45	30	100	1,35	SR355046
74	45	45	30	150	1,35	SR355047
74	45	45	30	200	1,35	SR355048
94	45	65	30	54	1,45	SR355064
94	45	65	30	75	1,45	SR355065
94	45	65	30	100	1,45	SR355066
94	45	65	30	150	1,45	SR355067
94	45	65	30	200	1,45	SR355068
124	45	95	30	54	1,65	SR355094
124	45	95	30	75	1,65	SR355095
124	45	95	30	100	1,65	SR355096
124	45	95	30	150	1,65	SR355097
124	45	95	30	200	1,65	SR355098

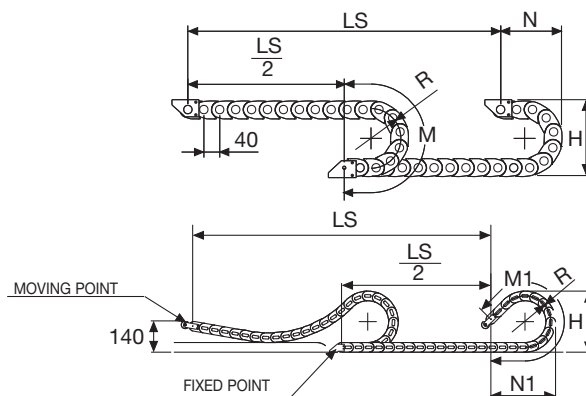

R	H	N	M	N1	M1
mm	mm	mm	mm	mm	mm
75	194	140	315	190	420
100	244	165	395	275	640
150	344	215	555	450	1075
200	444	265	710	620	1515

Length of chain (L)
Half travel distance ($\frac{LS}{2}$)
plus length of curve (M) or (M1)

$$L = \frac{LS}{2} + M \text{ or } M1$$



Self-Supporting Capacity Diagram

The maximum length of the self-supporting capacity ($\frac{LS}{2}$) in relationship to the weight of the cables and hoses contained per linear metre.

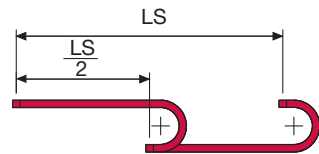
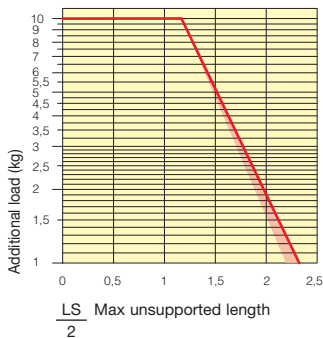

The red marking in the diagram area considers the difference of weight between various widths of chain.

For applications with $\frac{LS}{2}$ and weights not included in the area of the diagram showing self-supporting capacity, verify the possible use of support rollers (see page 30).

End Brackets

The end brackets set allows the two ends of the chain to be attached to the equipment.

Nylon Type

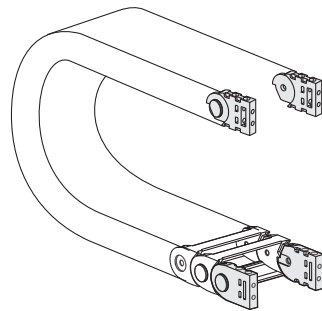

Fig. A
The chain can be fixed frontally, inner or outer radius. (Fig A)

Bright Zinc Plated Steel Type***

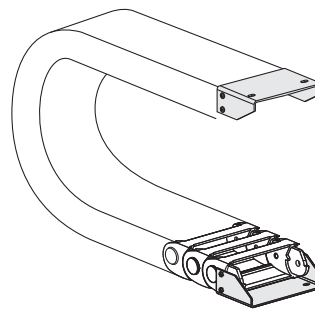
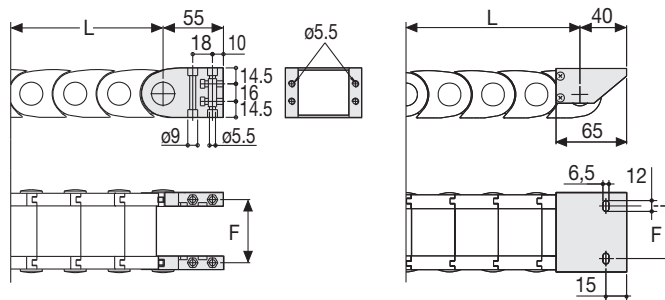

Fig. B
Chain fixed outside the radius. (Fig B)
See end brackets mounting variations page 31.



Chain Type	F mm
SR355 C=45	57
SR355 C=65	77
SR355 C=95	107

Chain Type	F mm
SR355 C=45	50
SR355 C=65	70
SR355 C=95	100

Nylon Type Part Numbers

Complete Set Assembled	
Chain Type	End Brackets Set
SR355 C=45	AN355KM
SR355 C=65	AN355KM
SR355 C=95	AN355KM

Complete Set Unassembled	
Chain Type	End Brackets Set
SR355 C=45	AN355K
SR355 C=65	AN355K
SR355 C=95	AN355K

Bright Zinc Plated Steel Type Part Numbers

Complete Set Assembled	
Chain Type	End Brackets Set
SR355 C=45	AP355KM□**
SR355 C=65	AM355KM□**
SR355 C=95	AG355KM□**

Complete Set Unassembled	
Chain Type	End Brackets Set
SR355 C=45	AP355K□**
SR355 C=65	AM355K□**
SR355 C=95	AG355K□**

** 1=Pos.1; 2=Pos.2; 3=Pos.3
*** Available on request in stainless steel

Serie Medium

SR355 Nylon Cable Chain Type***



Suitable to long travel distance.
To choose the guide channel see page 84

Special tool to remove the connecting pivots:
Part Number PZ010.



For further information please consult Brevetti Stendalto's Technical Office