

Solutions for Construction Industry

Construction



MARKETS &
APPLICATIONS





Construction Industry



Building Construction

Page 4 to 15



Earth Moving Machines

Page 16 to 21



Road Machinery

Page 22 to 31



Concrete Processes

Page 32 to 37



Asphalt Plant

Page 38 to 43



Cement Plant

Page 44 to 49

The broadest range of solutions for the Construction Industry

Enhancing construction equipment performance, efficiency, productivity and reliability is what we've done for over 40 years.

With experience alongside the major players in the world, our team of experts creates, designs and produces advanced technology solutions for a wide range of applications, such as transit mixer trucks, drilling equipment and cranes.

Our range of products, including planetary drives, drum drives, track drives, slew drives or winch drives, is perfectly tailored to meet a broad variety of drive specifications and is making us global leader in this industry.

Bonfiglioli also provides solutions for:



ACCESS & AERIAL PLATFORMS



BUILDING CONSTRUCTION



EARTH-MOVING MACHINES



ROAD CONSTRUCTION

www.bonfiglioli.com



Building Construction

Building Cranes
Page 6

1

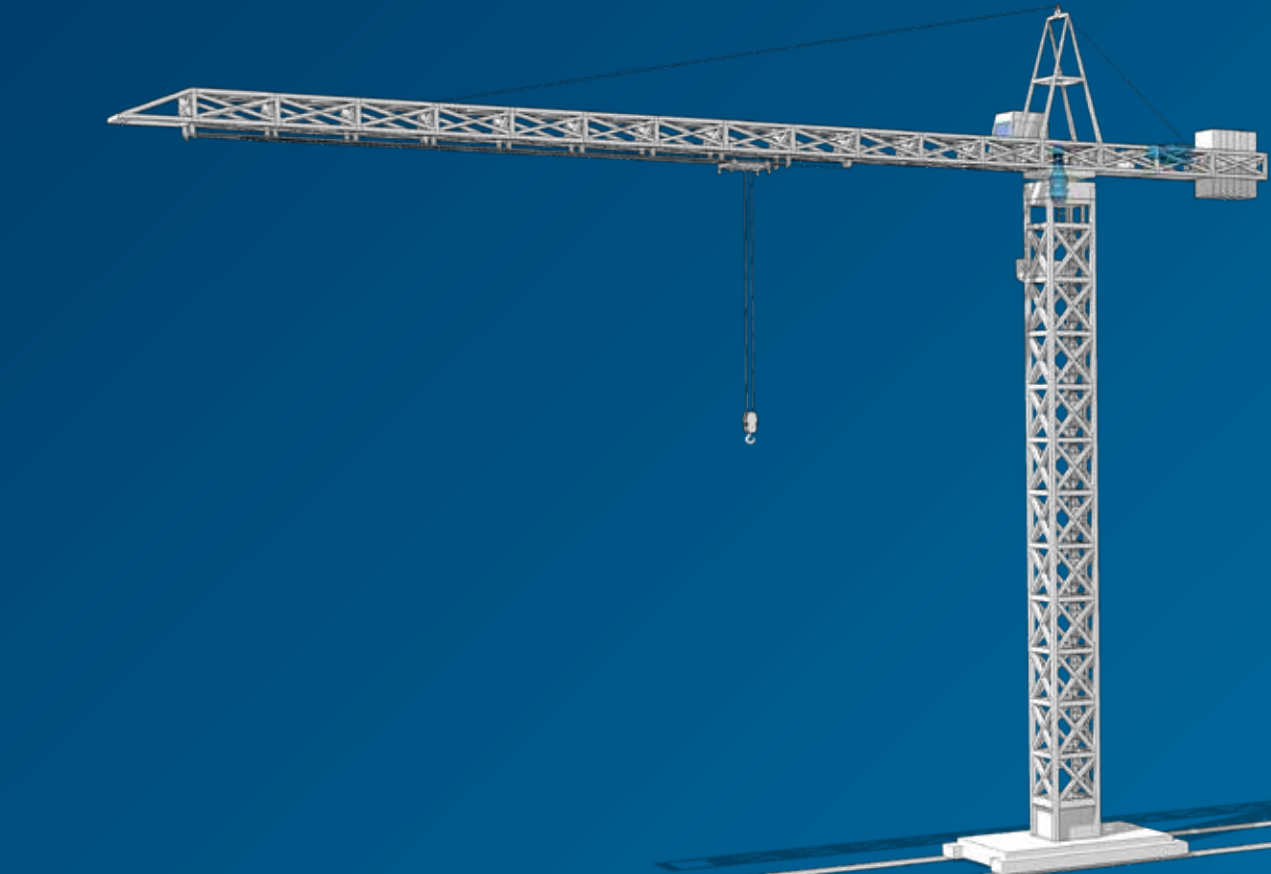

Crushers & Screeners
Page 14

6

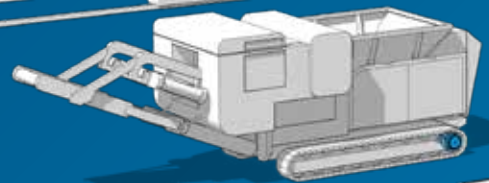

Truck-Mounted Cranes
Page 9

3



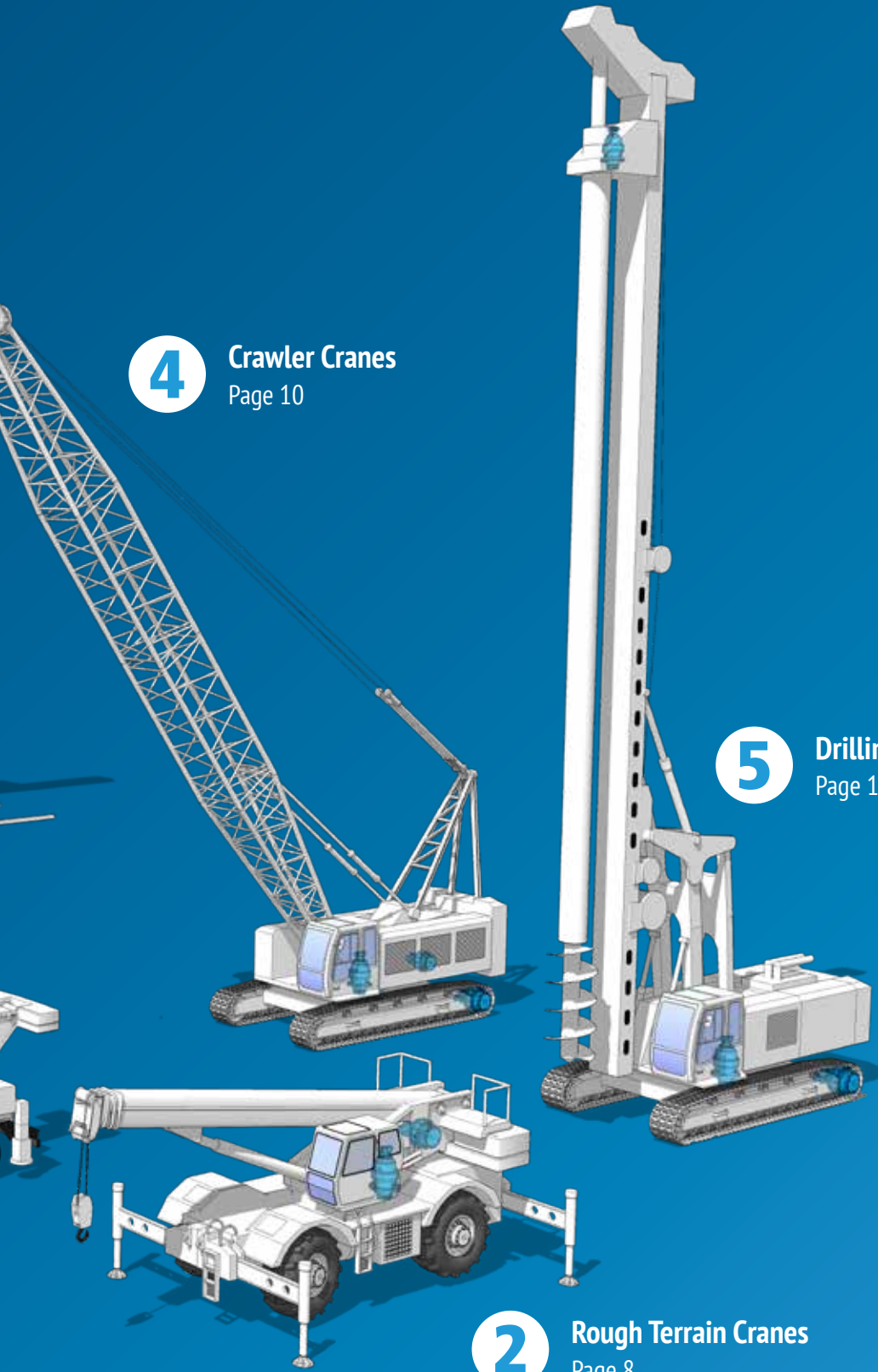

4

Crawler Cranes
Page 10

5

Drilling Machines
Page 12

2

Rough Terrain Cranes
Page 8

Building Construction

1

Building cranes

Slew drives

Bonfiglioli slew drives provide the safest, most effective solution for building cranes. Thanks to long established experience, Bonfiglioli offers robust and reliable products that meet its customers' needs.

Slew drives

700T Series

Output torque

- 1,200 ... 80,000 Nm

Gear ratios

- 3.48 ... 2,000

Benefits

- Safe & Efficient solutions
- Robustness
- Adaptability
- High torque capacity

Features

- Flange mounted
- Output shaft: splined or with integral pinion
- Rugged construction
- Notchless ground tooth root
- Integrated disc-brake
- High availability by highest teeth and production quality

S Series

Output torque

- 5,5 ... 130 kNm

Gear ratios

- 23 ... 67

Benefits

- Safe & Efficient solutions
- Robustness
- Adaptability
- High torque capacity

Features

- Flange mounted
- Output shaft: splined or with integral pinion
- Rugged construction
- Notchless ground tooth root
- Integrated disc-brake
- High availability by highest teeth and production quality





Winch drives

Based on the specific application requirements, each winch drive for lifting or pulling cranes is developed to improve the performance and work within the small spaces available.

Trolley & lifting drives

Bonfiglioli's range of products dedicated to handling cranes provides excellent lifting and trolley performance and long life. Both the proper alignment of the cranes and the lift machinery are improved by our solutions.

Winch drives 700C Series

Output torque

- 2,500 ... 625,000 Nm

Gear ratios

- 5.3 ... 492

Benefits

- Compact structure
- Robust layout of planetary gear unit
- High torque & load capacity

Features

- Rotating housing flange
- Rugged construction
- Integrated disc-brake
- Easy oil change from front side
- Easy drum mounting

800 Series

Output torque

- 5,000 ... 42,000 Nm

Gear ratios

- 22 ... 108

Benefits

- Compact structure
- Robust layout of planetary gear unit
- High torque & load capacity

Features

- Rotating housing flange
- Rugged construction
- Integrated disc-brake
- Easy oil change from front side
- Easy drum mounting

FW Series

Output torque

- 5,4 ... 210 kNm

Gear ratios

- 35 ... 490

Benefits

- Compact structure
- Robust layout of planetary gear unit
- High torque & load capacity

Features

- Rotating housing flange
- Rugged construction
- Integrated disc-brake
- Easy oil change from front side
- Easy drum mounting



Building Construction

2

Rough Terrain Cranes



Slew drives

Bonfiglioli slew drives provide the safest, most effective solution for rough terrain cranes. Our products' flexibility matches the versatility of this typical application, allowing the highest reach and the best maneuverability.

Winch drives

Based on the specific application requirements, each winch drive for rough terrain cranes is developed to improve performance in the space available.

Slew drives

700T Series

Output torque

- 1,200 ... 20,000 Nm

Gear ratios

- 100 ... 200

Benefits

- Safe & Efficient solutions
- Robustness
- Adaptability
- High torque capacity

Features

- Flange mounted
- Output shaft: splined or with integral pinion
- Rugged construction
- Notchless ground tooth root
- Integrated disc-brake
- High availability by highest teeth and production quality

S Series

Output torque

- 5,5 ... 130 kNm

Gear ratios

- 23 ... 67

Benefits

- Safe & Efficient solutions
- Robustness
- Adaptability
- High torque capacity

Features

- Flange mounted
- Output shaft: splined or with integral pinion
- Rugged construction
- Notchless ground tooth root
- Integrated disc-brake
- High availability by highest teeth and production quality

Winch drives

700C Series

Output torque

- 2,500 ... 625,000 Nm

Gear ratios

- 5.3 ... 492

Benefits

- Compact structure
- Robust layout of planetary gear unit
- High torque & load capacity

Features

- Rotating housing flange
- Rugged construction
- Integrated disc-brake
- Easy oil change from front side
- Easy drum mounting

800 Series

Output torque

- 5,000 ... 42,000 Nm

Gear ratios

- 22 ... 108

Benefits

- Compact structure
- Robust layout of planetary gear unit
- High torque & load capacity

Features

- Rotating housing flange
- Rugged construction
- Integrated disc-brake
- Easy oil change from front side
- Easy drum mounting





3

Truck-Mounted Cranes



Slew drives

Bonfiglioli slew drives provide the safest, most effective solution for truck-mounted cranes. Our products' flexibility matches the versatility of this typical application, allowing the highest reach and the best maneuverability.

Winch drives

Based on the specific application requirements, each lifting or pulling truck-mounted winch drive is developed to improve performance in the space available.

Slew drives 700T Series

Output torque

- 1,200 ... 20,000 Nm

Gear ratios

- 100 ... 200

Benefits

- Safe & Efficient solutions
- Robustness
- Adaptability
- High torque capacity

Features

- Flange mounted
- Output shaft: splined or with integral pinion
- Rugged construction
- Notchless ground tooth root
- Integrated disc-brake
- High availability by highest teeth and production quality

S Series

Output torque

- 5,5 ... 130 kNm

Gear ratios

- 23 ... 67

Benefits

- Safe & Efficient solutions
- Robustness
- Adaptability
- High torque capacity

Features

- Flange mounted
- Output shaft: splined or with integral pinion
- Rugged construction
- Notchless ground tooth root
- Integrated disc-brake
- High availability by highest teeth and production quality

Winch drives 700C Series

Output torque

- 2,500 ... 625,000 Nm

Gear ratios

- 5.3 ... 492

Benefits

- Compact structure
- Robust layout of planetary gear unit
- High torque & load capacity

Features

- Rotating housing flange
- Rugged construction
- Integrated disc-brake
- Easy oil change from front side
- Easy drum mounting



Building Construction

4

Crawler Cranes

Track drives

With a reliable series of products, Bonfiglioli gives OEMs the best possible choice of a track drive system for crawler cranes. The reliability and robustness of this series allow the machine to resist harsh environments and extend life service.

Slew drives

700T Series

Output torque

- 1,200 ... 20,000 Nm

Gear ratios

- 100 ... 200

Benefits

- Safe & Efficient solutions
- Robustness
- Adaptability
- High torque capacity

Features

- Flange mounted
- Output shaft: splined or with integral pinion
- Rugged construction
- Notchless ground tooth root
- Integrated disc-brake
- High availability by highest teeth and production quality

S Series

Output torque

- 5,5 ... 130 kNm

Gear ratios

- 23 ... 67

Benefits

- Safe & Efficient solutions
- Robustness
- Adaptability
- High torque capacity

Features

- Flange mounted
- Output shaft: splined or with integral pinion
- Rugged construction
- Notchless ground tooth root
- Integrated disc-brake
- High availability by highest teeth and production quality

Winch drives

800 Series

Output torque

- 5,000 ... 17,500 Nm

Gear ratios

- 21 ... 53

Benefits

- Compact structure
- Robust layout of planetary gear unit
- High torque & load capacity

Features

- Rotating housing flange
- Rugged construction
- Integrated disc-brake
- Easy oil change from front side
- Easy drum mounting





Slew drives

Our slew drives provide the safest, most effective solution to crawler cranes. Our products' flexibility matches the versatility of this typical application, allowing the highest reach and the best maneuverability.

Winch drives

Based on the specific application requirements, each winch drive for lifting or pulling cranes is developed to improve the performance and work within the small spaces available.

Track drives

700CK Series

Output torque

- 1,200 ... 220,000 Nm

Gear ratios

- 20 ... 120

Benefits

- Safe & Efficient solutions
- Robustness
- Adaptability
- High torque capacity

Features

- Flange mounted
- Output shaft: splined or with integral pinion
- Rugged construction
- Notchless ground tooth root
- Integrated disc-brake
- High availability by highest teeth and production quality

700C Series

Output torque

- 18,000 ... 60,000 Nm

Gear ratios

- 35 ... 166

Benefits

- Safe & Efficient solutions
- Robustness
- Adaptability
- High torque capacity

Features

- Flange mounted
- Output shaft: splined or with integral pinion
- Rugged construction
- Notchless ground tooth root
- Integrated disc-brake
- High availability by highest teeth and production quality

FP Series

Output torque

- 100 ... 1,100 kNm

Gear ratios

- 248 ... 825

Benefits

- Safe & Efficient solutions
- Robustness
- Adaptability
- High torque capacity

Features

- Flange mounted
- Output shaft: splined or with integral pinion
- Rugged construction
- Notchless ground tooth root
- Integrated disc-brake
- High availability by highest teeth and production quality



Building Construction



Drilling Machines

5

Track drives

Thanks to reliable series of products, Bonfiglioli gives every OEM the best possible options for choosing a track drive system. High performance, including high torque in a compact space, is one of our portfolio's key benefits.

Slew drives

700T Series

Output torque

- 1,200 ... 20,000 Nm

Gear ratios

- 100 ... 200

Benefits

- Safe & Efficient solutions
- Robustness
- Adaptability
- High torque capacity

Features

- Flange mounted
- Output shaft: splined or with integral pinion
- Rugged construction
- Notchless ground tooth root
- Integrated disc-brake
- High availability by highest teeth and production quality

S Series

Output torque

- 5,5 ... 130 kNm

Gear ratios

- 23 ... 67

Benefits

- Safe & Efficient solutions
- Robustness
- Adaptability
- High torque capacity

Features

- Flange mounted
- Output shaft: splined or with integral pinion
- Rugged construction
- Notchless ground tooth root
- Integrated disc-brake
- High availability by highest teeth and production quality

Track drives

700C & 700CK Series

Output torque

- 1,200 ... 220,000 Nm

Gear ratios

- 20 ... 166

Benefits

- Compact design
- High torque & load capacity
- Available with failsafe parking brake and for most cartridge type fixed or variable.

Features

- Rotating housing
- Rugged design
- Mechanical lifetime seals
- 3-7 Planetary wheels per stage
- Notchless ground tooth root
- Different ratios
- Integrated disc-brake

F series

Output torque

- 100 ... 900 kNm

Gear ratios

- 248 ... 825

Benefits

- Compact design
- High torque & load capacity
- Available with failsafe parking brake and for most cartridge type fixed or variable.

Features

- Rotating housing
- Rugged design
- Mechanical lifetime seals
- 3-7 Planetary wheels per stage
- Notchless ground tooth root
- Different ratios
- Integrated disc-brake





Slew drives

Reliability and high torque capabilities are the two key benefits of our slew drive applications for drilling rigs from 180 up to 400 tons.

Winch drives

Bonfiglioli has also developed drill rotation and control solutions capable of transmitting up to 42,000 Nm of torque.

Rotary head drives

By supplying the necessary power to the drilling machine, the rotary head drives allow more efficiency and resistance to long work times. Bonfiglioli has developed drives that excellently meet these requirements.

Winch drives

700C Series

Output torque

- 2,500 ... 625,000 Nm

Gear ratios

- 5.3 ... 492

Benefits

- Compact structure
- Robust layout of planetary gear unit
- High torque & load capacity

Features

- Rotating housing flange
- Rugged construction
- Integrated disc-brake
- Easy oil change from front side
- Easy drum mounting

800 Series

Output torque

- 5,000 ... 42,000 Nm

Gear ratios

- 22 ... 108

Benefits

- Compact structure
- Robust layout of planetary gear unit
- High torque & load capacity

Features

- Rotating housing flange
- Rugged construction
- Integrated disc-brake
- Easy oil change from front side
- Easy drum mounting

FW Series

Output torque

- 5,4 ... 210 kNm

Gear ratios

- 35 ... 490

Benefits

- Compact structure
- Robust layout of planetary gear unit
- High torque & load capacity

Features

- Rotating housing flange
- Rugged construction
- Integrated disc-brake
- Easy oil change from front side
- Easy drum mounting

Rotary head drives

300 Series

Output torque

- 1,000 ... 1,100,000 Nm

Gear ratios

- 3,4 ... 5,000

Benefits

- Compact & Powerful
- Resistent to shock loads
- High versatility

Features

Output Configurations

- Foot and flange mounted
- Output shaft: solid with key, splined, splined hollow, hollow with shrink disc

Input Configurations

- Flanged axial piston hydraulic motors
- Hydraulic orbit motors
- IEC and Nema motor adaptors
- Solid input shaft



Building Construction

6

Crushers & Screeners

Conveyor drives

The performance of Bonfiglioli's drives eliminates maintenance-intensive gearboxes, helping our customers increase reliability and cut costs.

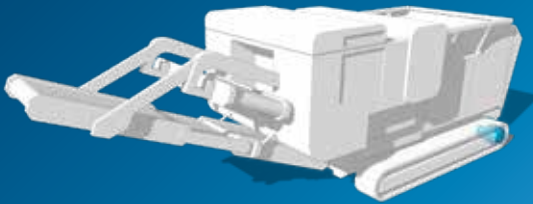

Track drives

700CK Series

Output torque

- 1,200 ... 220,000 Nm

Gear ratios

- 20 ... 120

Benefits

- Safe & Efficient solutions
- Robustness
- Adaptability
- High torque capacity

Features

- Flange mounted
- Output shaft: splined or with integral pinion
- Rugged construction
- Notchless ground tooth root
- Integrated disc-brake
- High availability by highest teeth and production quality

700CP Series

Output torque

- 1,200 ... 5,000 Nm

Gear ratios

- 18.5 ... 57.5

Benefits

- Safe & Efficient solutions
- Robustness
- Adaptability
- High torque capacity

Features

- Flange mounted
- Output shaft: splined or with integral pinion
- Rugged construction
- Notchless ground tooth root
- Integrated disc-brake
- High availability by highest teeth and production quality

700CE Series

Output torque

- 26,000 ... 60,000 Nm

Gear ratios

- 123 ... 350

Benefits

- Safe & Efficient solutions
- Robustness
- Adaptability
- High torque capacity

Features

- Flange mounted
- Output shaft: splined or with integral pinion
- Rugged construction
- Notchless ground tooth root
- Integrated disc-brake
- High availability by highest teeth and production quality

F Series

Output torque

- 100 ... 900 kNm

Gear ratios

- 248 ... 825

Benefits

- Safe & Efficient solutions
- Robustness
- Adaptability
- High torque capacity

Features

- Flange mounted
- Output shaft: splined or with integral pinion
- Rugged construction
- Notchless ground tooth root
- Integrated disc-brake
- High availability by highest teeth and production quality





Track drives

With a reliable series of products for crushing equipment, Bonfiglioli gives OEMs the best possible choice of a track drive system. High performance, including high torque in a compact space, is one of our portfolio's key benefits. These solutions give the machine smooth operation and long product life.

Winch drives

700C Series

Output torque

- 2,500 ... 30,000 Nm

Gear ratios

- 19 ... 166

Benefits

- Compact structure
- Robust layout of planetary gear unit
- High torque & load capacity

Features

- Rotating housing flange
- Rugged construction
- Integrated disc-brake
- Easy oil change from front side
- Easy drum mounting

800 Series

Output torque

- 5,000 ... 17,500 Nm

Gear ratios

- 21 ... 53

Benefits

- Compact structure
- Robust layout of planetary gear unit
- High torque & load capacity

Features

- Rotating housing flange
- Rugged construction
- Integrated disc-brake
- Easy oil change from front side
- Easy drum mounting



Earth Moving Machines

2**Excavators**

Page 19

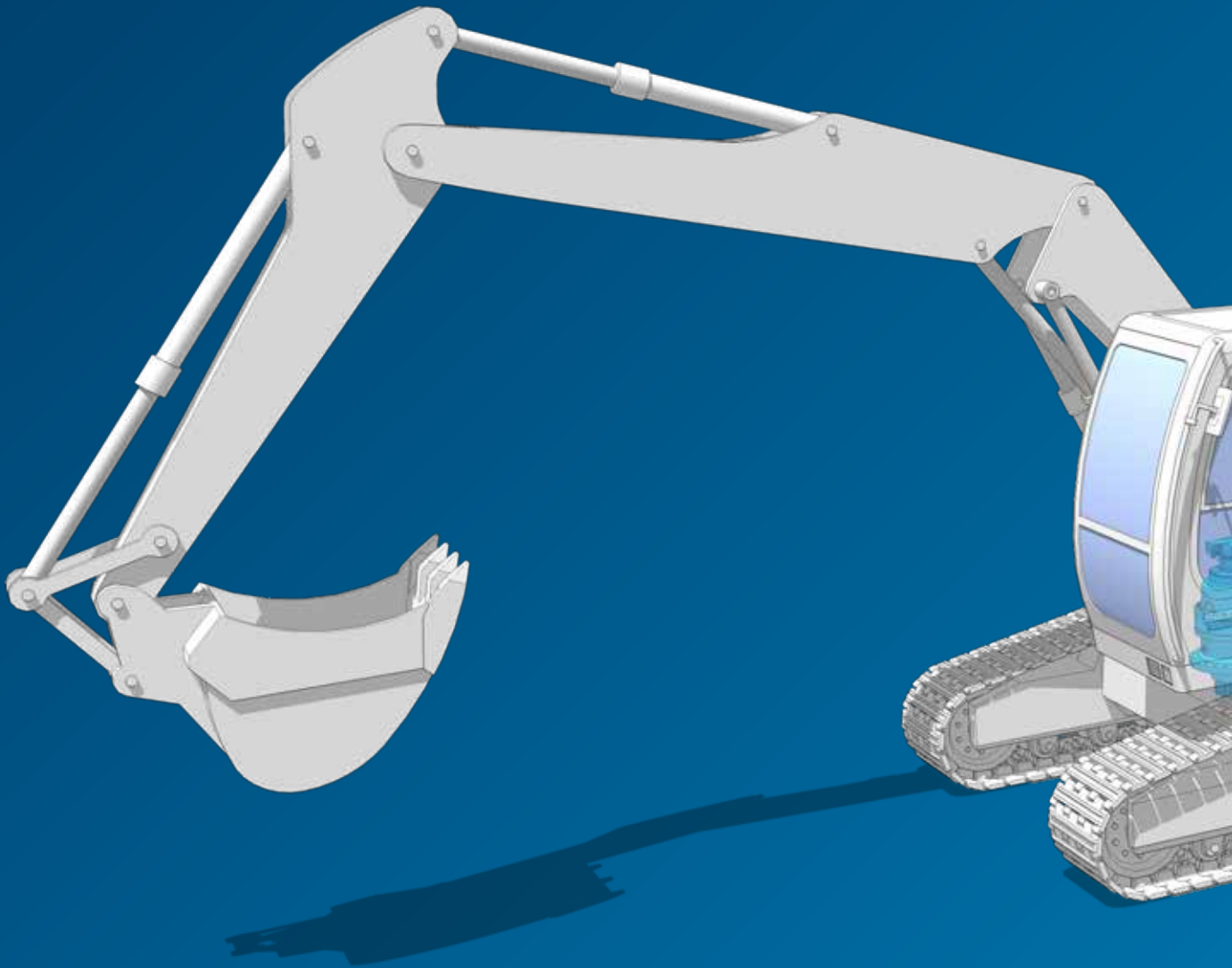



1

Mini-Excavators

Page 18

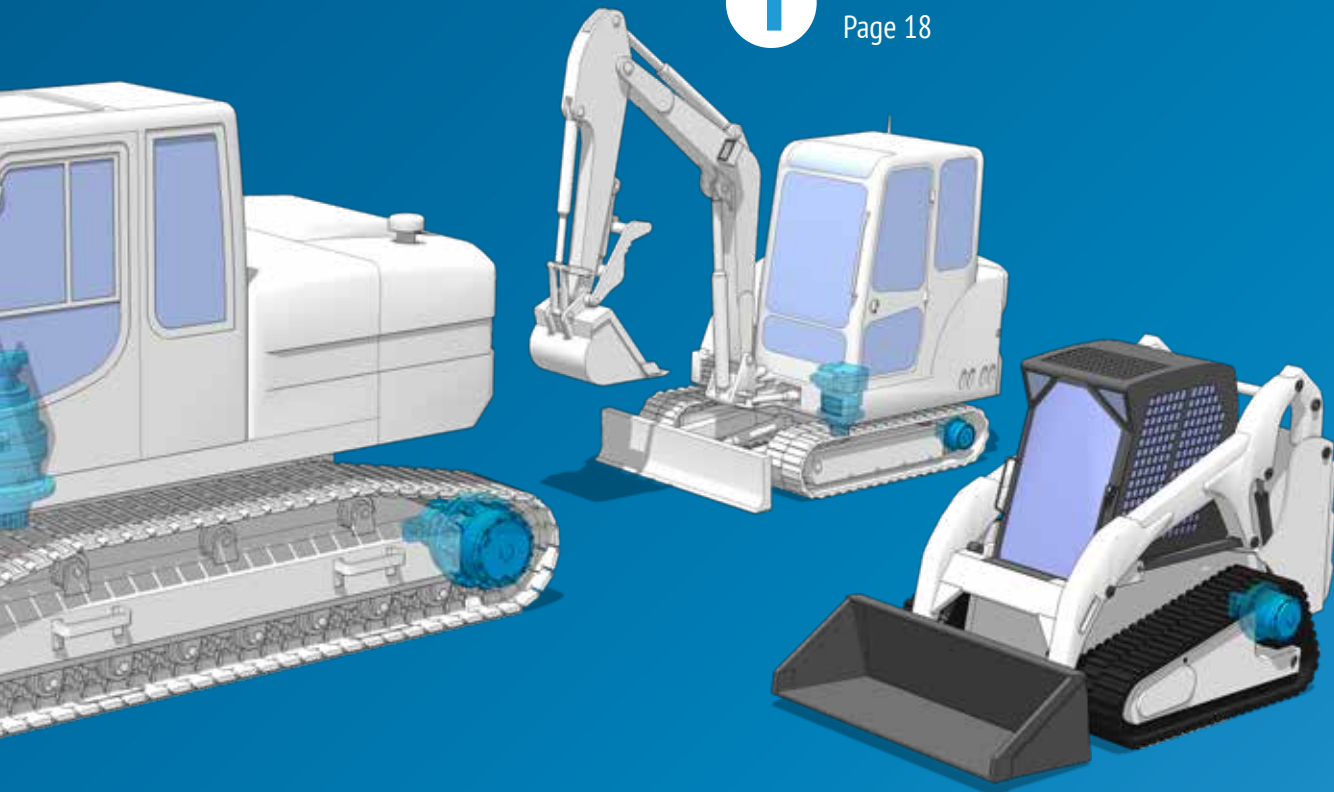

Compact Track Loader

Page 20

3

Earth Moving Machines

1

Mini-Excavators

Track drives

High performance, including high torque in a compact space, is one of our portfolio's key benefits. These solutions allow smooth machine operation.

Winch drives

The compactness and efficiency of Bonfiglioli slew drives for 1 to 6 ton mini-excavators ensure the best possible machine efficiency and easy maintenance.

Track drives

700CK Series

Output torque

- 1,200 ... 5,000 Nm

Gear ratios

- 32 ... 53

Benefits

- Compact design
- High torque & load capacity
- Available with failsafe parking brake and for most cartridge type fixed or variable.

Features

- Rotating housing
- Rugged design
- Mechanical lifetime seals
- 3-7 Planetary wheels per stage
- Notchless ground tooth root
- Different ratios
- Integrated disc-brake

700CP Series

Output torque

- 1,200 ... 5,000 Nm

Gear ratios

- 18.5 ... 57.5

Benefits

- Compact design
- High torque & load capacity
- Available with failsafe parking brake and for most cartridge type fixed or variable.

Features

- Rotating housing
- Rugged design
- Mechanical lifetime seals
- 3-7 Planetary wheels per stage
- Notchless ground tooth root
- Different ratios
- Integrated disc-brake

Slew drives

700TK Series

Output torque

- 750 ... 2,000 Nm

Gear ratios

- 6 ... 26

Benefits

- Safe & Efficient solutions
- Robustness
- Adaptability
- High torque capacity

Features

- Flange mounted
- Output shaft: splined or with integral pinion
- Rugged construction
- Notchless ground tooth root
- Integrated disc-brake
- High availability by highest teeth and production quality





2

Excavators

Track drives

High performance, including high torque in a compact space, is one of our portfolio's key benefits. These solutions allow smooth machine operation.

Winch drives

The compactness and efficiency of Bonfiglioli slew drives for 7 to 150 tons excavators, ensure the best possible machine efficiency and easy maintenance.



Track drives

700CK Series

Output torque

- 9,000 ... 240,000 Nm

Gear ratios

- 40 ... 82

Benefits

- Compact design
- High torque & load capacity
- Available with failsafe parking brake and for most cartridge type fixed or variable.

Features

- Rotating housing
- Rugged design
- Mechanical lifetime seals
- 3-7 Planetary wheels per stage
- Notchless ground tooth root
- Different ratios
- Integrated disc-brake

FP Series

Output torque

- 100 ... 1,100 kNm

Gear ratios

- 248 ... 825

Benefits

- Compact design
- High torque & load capacity
- Available with failsafe parking brake and for most cartridge type fixed or variable.

Features

- Rotating housing
- Rugged design
- Mechanical lifetime seals
- 3-7 Planetary wheels per stage
- Notchless ground tooth root
- Different ratios
- Integrated disc-brake

Slew drives

700T & 700TK Series

Output torque

- 2,500 ... 30,000 Nm

Gear ratios

- 15 ... 35

Benefits

- Safe & Efficient solutions
- Robustness
- Adaptability
- High torque capacity

Features

- Flange mounted
- Output shaft: splined or with integral pinion
- Rugged construction
- Notchless ground tooth root
- Integrated disc-brake
- High availability by highest teeth and production quality

S Series

Output torque

- 5,5 ... 130 kNm

Gear ratios

- 23 ... 67

Benefits

- Safe & Efficient solutions
- Robustness
- Adaptability
- High torque capacity

Features

- Flange mounted
- Output shaft: splined or with integral pinion
- Rugged construction
- Notchless ground tooth root
- Integrated disc-brake
- High availability by highest teeth and production quality



Earth Moving Machines

3

Compact Track Loader

Track drives

With a reliable series of products for compact track loaders, Bonfiglioli gives OEM the best possible choice of drive systems. High performance, including high torque in a compact space, is one of our portfolio's key benefits. These solutions allow smooth machine operation.



Track drives

700XT Series

Output torque

- 12,000 ... 22,000 Nm

Gear ratios

- 22 ... 53

Benefits

- Compact design
- High torque & load capacity
- Available with failsafe parking brake and for most cartridge type fixed or variable.

Features

- Rotating housing
- Rugged design
- Mechanical lifetime seals
- 3-7 Planetary wheels per stage
- Notchless ground tooth root
- Different ratios
- Integrated disc-brake

700CT Series

Output torque

- 3,500 ... 12,500 Nm

Gear ratios

- 15 ... 53

Benefits

- Compact design
- High torque & load capacity
- Available with failsafe parking brake and for most cartridge type fixed or variable.

Features

- Rotating housing
- Rugged design
- Mechanical lifetime seals
- 3-7 Planetary wheels per stage
- Notchless ground tooth root
- Different ratios
- Integrated disc-brake

700CK Series

Output torque

- 1,200 ... 5,000 Nm

Gear ratios

- 32 ... 53

Benefits

- Compact design
- High torque & load capacity
- Available with failsafe parking brake and for most cartridge type fixed or variable.

Features

- Rotating housing
- Rugged design
- Mechanical lifetime seals
- 3-7 Planetary wheels per stage
- Notchless ground tooth root
- Different ratios
- Integrated disc-brake



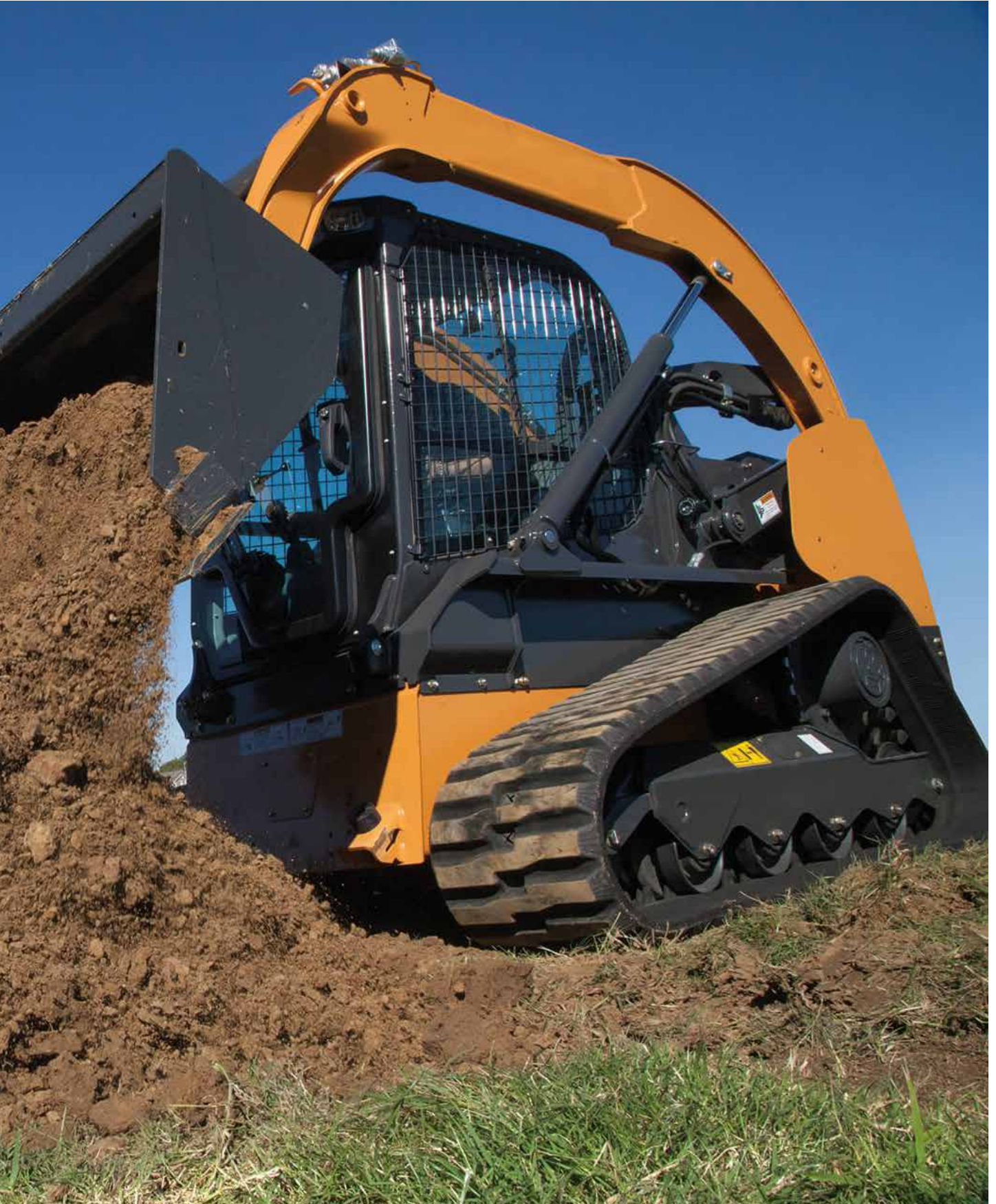

Road Machinery

Graders
Page 28

4



Cold Milling Machines
Page 31

7

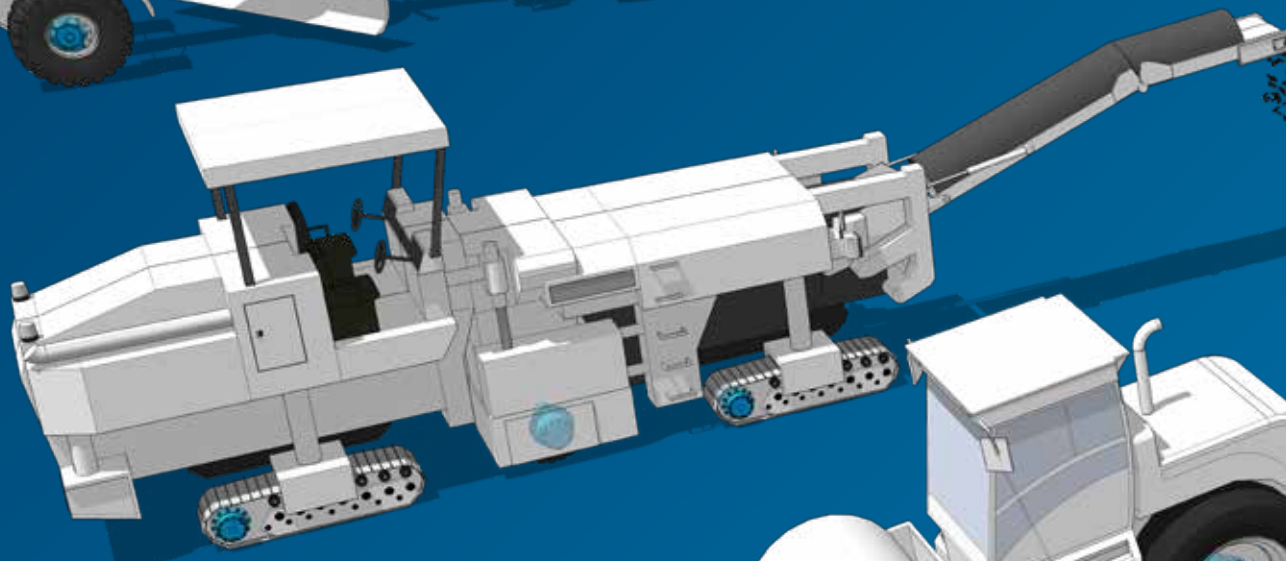

Soil Compactors
Page 27

3





2 Road Reclaimers
Page 26

1 Pavers
Page 24

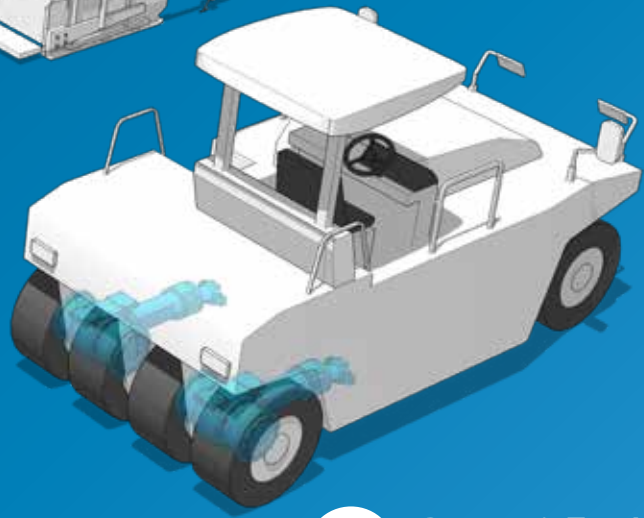
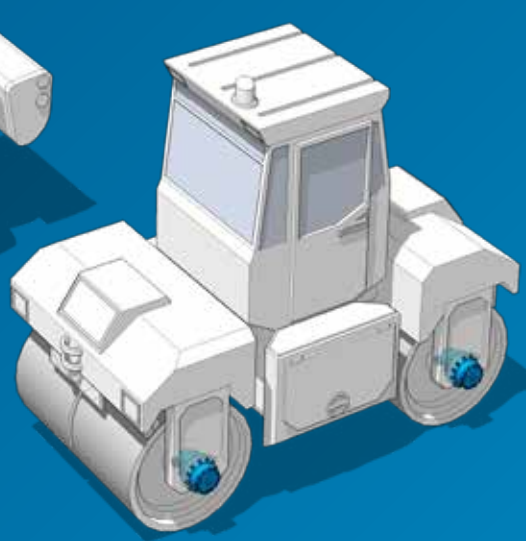
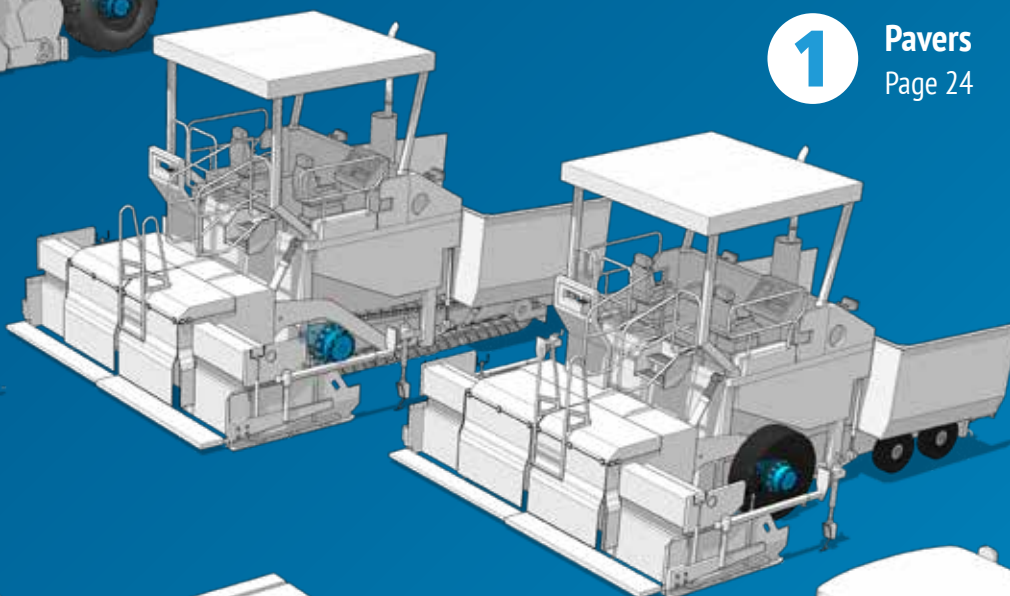

6 Tandem Vibratory Rollers
Page 30

5 Pneumatic Tyred Rollers
Page 29

Road Machinery

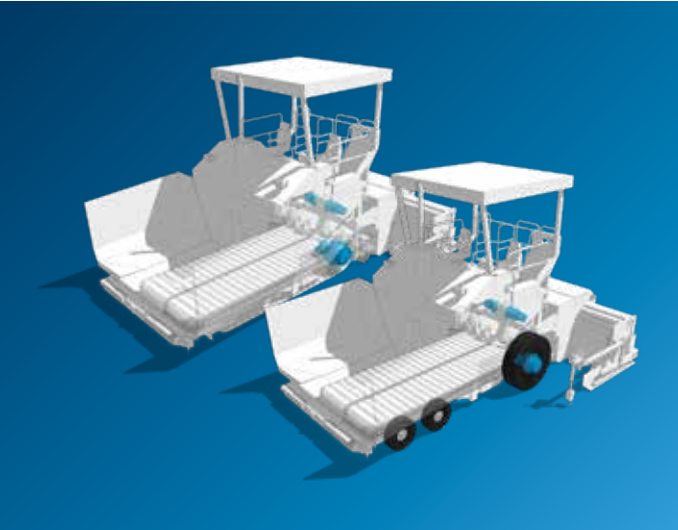

Pavers

1

Wheel drives

With a reliable series of products, Bonfiglioli gives paving machine builders the best possible choice of drive systems, allowing the machine to move back and forth. High performance, including high torque in a compact space with limited axial dimensions, is one of our portfolio's key benefits. All units are available with a fail-safe parking brake and most have a cartridge-type fixed or variable displacement hydraulic motor.

Wheel drives 600W2/3 Series

Output torque

- 15,000 ... 50,000 Nm

Gear ratios

- 20 ... 35 Hi-Speed
- 70 ... 234 Lo-Speed

Benefits

- Compact design
- High torque capacity
- Rugged design

Features

- Rotating housing flange with studs to fit wheels and drums
- Mechanical lifetime seals
- Optional mechanical gear disengagement on request

Auger drives 300 Series Mobile

Output torque

- 1,000 ... 1,100,000 Nm

Gear ratios

- 3,4 ... 5,000

Benefits

- Compact & Powerful
- Resistent to shock loads
- High versatility

Features

Output Configurations

- Foot and flange mounted
- Output shaft: solid with key, splined, splined hollow, hollow with shrink disc

Input Configurations

- Flanged axial piston hydraulic motors
- Hydraulic orbit motors
- IEC and Nema motor adaptors
- Solid input shaft





Auger drives

Bonfiglioli also offers also a specific solution for distribution augers that push asphalt outward to the desired width. Resistant to heavy loads, the range of products can also endure long hours of work.

Track drives

For any tracked paving machine, no matter how big or small, there is a suitable travel drive within the Bonfiglioli range, allowing the machine to move smoothly back and forth. All units are available with a fail-safe parking brake and most have a cartridge-type fixed or variable displacement hydraulic motor.

Track drives

700CT Series

Output torque

- 3,500 ... 12,500 Nm

Gear ratios

- 15 ... 53

Benefits

- Compact design
- High torque & load capacity
- Available with failsafe parking brake and for most cartridge type fixed or variable.

Features

- Rotating housing
- Rugged design
- Mechanical lifetime seals
- 3-7 Planetary wheels per stage
- Notchless ground tooth root
- Different ratios
- Integrated disc-brake

700C Series

Output torque

- 18,000 ... 60,000 Nm

Gear ratios

- 35 ... 166

Benefits

- Compact design
- High torque & load capacity
- Available with failsafe parking brake and for most cartridge type fixed or variable.

Features

- Rotating housing
- Rugged design
- Mechanical lifetime seals
- 3-7 Planetary wheels per stage
- Notchless ground tooth root
- Different ratios
- Integrated disc-brake

F Series

Output torque

- 13 ... 100 kNm

Gear ratios

- 35 ... 305

Benefits

- Compact design
- High torque & load capacity
- Available with failsafe parking brake and for most cartridge type fixed or variable.

Features

- Rotating housing
- Rugged design
- Mechanical lifetime seals
- 3-7 Planetary wheels per stage
- Notchless ground tooth root
- Different ratios
- Integrated disc-brake



Road Machinery

2

Road Reclaimers

Wheel drives

With a reliable series of products for road reclaimers and graders, Bonfiglioli gives machine builders the best possible choice of drive systems. High performance, including high torque in a compact space with limited axial dimensions, is one of our portfolio's key benefits. These solutions include an optional disengagement device for towing the machine in an emergency.

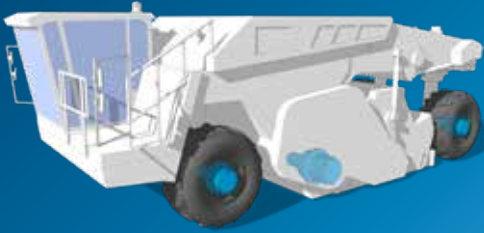

Wheel drives 600 Series

Output torque

- 30,000 ... 60,000 Nm

Gear ratios

- 65 ... 127

Benefits

- Compact design
- High torque capacity
- Rugged design

Features

- Rotating housing flange with studs to fit wheels and drums
- Mechanical lifetime seals
- Optional mechanical gear disengagement on request





3

Soil Compactors



Wheel drives

High performance, including high torque in a compact space with limited axial dimensions, is one of our portfolio's key benefits.

Drum drives

Extreme compactness, light weight, efficiency and smooth operation are the key features of Bonfiglioli travel drives for soil compactor machines.

Wheel drives 600 Series

Output torque

- 4,000 ... 23,000 Nm

Gear ratios

- 19 ... 147

Benefits

- Compact design
- High torque capacity
- Rugged design

Features

- Rotating housing flange with studs to fit wheels and drums
- Mechanical lifetime seals
- Optional mechanical gear disengagement on request

Drum drives 700C Series

Output torque

- 26,000 ... 60,000 Nm

Gear ratios

- 55 ... 166

Benefits

- Compact design
- High torque & load capacity
- Available with failsafe parking brake and for most cartridge type fixed or variable.

Features

- Rotating housing
- Rugged design
- Mechanical lifetime seals
- 3-7 Planetary wheels per stage
- Notchless ground tooth root
- Different ratios
- Integrated disc-brake

F Series

Output torque

- 13 ... 100 kNm

Gear ratios

- 35 ... 305

Benefits

- Compact design
- High torque & load capacity
- Available with failsafe parking brake and for most cartridge type fixed or variable.

Features

- Rotating housing
- Rugged design
- Mechanical lifetime seals
- 3-7 Planetary wheels per stage
- Notchless ground tooth root
- Different ratios
- Integrated disc-brake



Road Machinery



4

Graders

Wheel drives

With a reliable series of products for road reclaimers and graders, Bonfiglioli gives machine builders the best possible choice of drive systems. High performance, including high torque in a compact space with limited axial dimensions, is one of our portfolio's key benefits. These solutions include an optional disengagement device for towing the machine in an emergency.

Wheel drives 600 Series

Output torque

- 15,000 Nm

Gear ratios

- 30

Benefits

- Customized & Compact design
- Resistent
- High performance

Features

- Included high-speed clutch device





5

Pneumatic Tyred Rollers

Wheel drives

With a reliable series of products, Bonfiglioli gives builders of pneumatic tired rollers the best possible choice of drive systems. High performance, including high torque in a compact space with limited axial dimensions, is one of our portfolio's key benefits.



Wheel drives 600Y Series

Output torque

- 14,000 ... 22,000 Nm

Gear ratios

- 30 ... 32

Benefits

- Customized & Compact design
- Resistent
- High performance

Features

- Brake designed for
 - Parking
 - Emergency stops
 - Dynamic braking at low speed (inching)
- Cartridge axial piston hydraulic motors
- Flanged axial piston hydraulic motors



Road Machinery



Tandem Vibratory Rollers

6

Drum drives

Bonfiglioli supplies efficient solutions with integrated, high-performance hydraulic motors and low maintenance braking systems for tandem vibratory roller machines.

Drum drives

700C Series

Output torque

- 1,000 ... 60,000 Nm

Gear ratios

- 5.25 ... 166

Benefits

- Compact design
- High torque & load capacity
- Available with failsafe parking brake and for most cartridge type fixed or variable.

Features

- Rotating housing
- Rugged design
- Mechanical lifetime seals
- 3-7 Planetary wheels per stage
- Notchless ground tooth root
- Different ratios
- Integrated disc-brake





7

Cold Milling Machines



Wheel drives

High performance, including high torque in a compact space with limited axial dimensions, is one of our wheeled drive portfolio's key benefits.

Cutter drives

Bonfiglioli cutter drives are also designed to withstand harsh environments and can endure critical temperatures without any risk of the breakage that typically occurs with cold milling machines.

Wheel drives 600 Series

Output torque

- 4,000 ... 60,000 Nm

Gear ratios

- 19 ... 147

Benefits

- Compact design
- High torque capacity
- Rugged design

Features

- Rotating housing flange with studs to fit wheels and drums
- Mechanical lifetime seals
- Optional mechanical gear disengagement on request

Cutter drives 700C Series

Output torque

- 20,000 ... 45,000 Nm

Gear ratios

- 16 ... 22.9

Benefits

- Optimized housing design
- Compact structure
- High performance

Features

- Dual stage planetary reduction
- Integrated pulley support shaft with reinforced bearings
- Notchless ground tooth root

FA Series

Output torque

- 8,5 ... 115 kNm

Gear ratios

- 14 ... 26

Benefits

- Optimized housing design
- Compact structure
- High performance

Features

- Dual stage planetary reduction
- Integrated pulley support shaft with reinforced bearings
- Notchless ground tooth root



Concrete Processes

Concrete Mixer
Page 35

2

Skip Hoist
Page 34

1

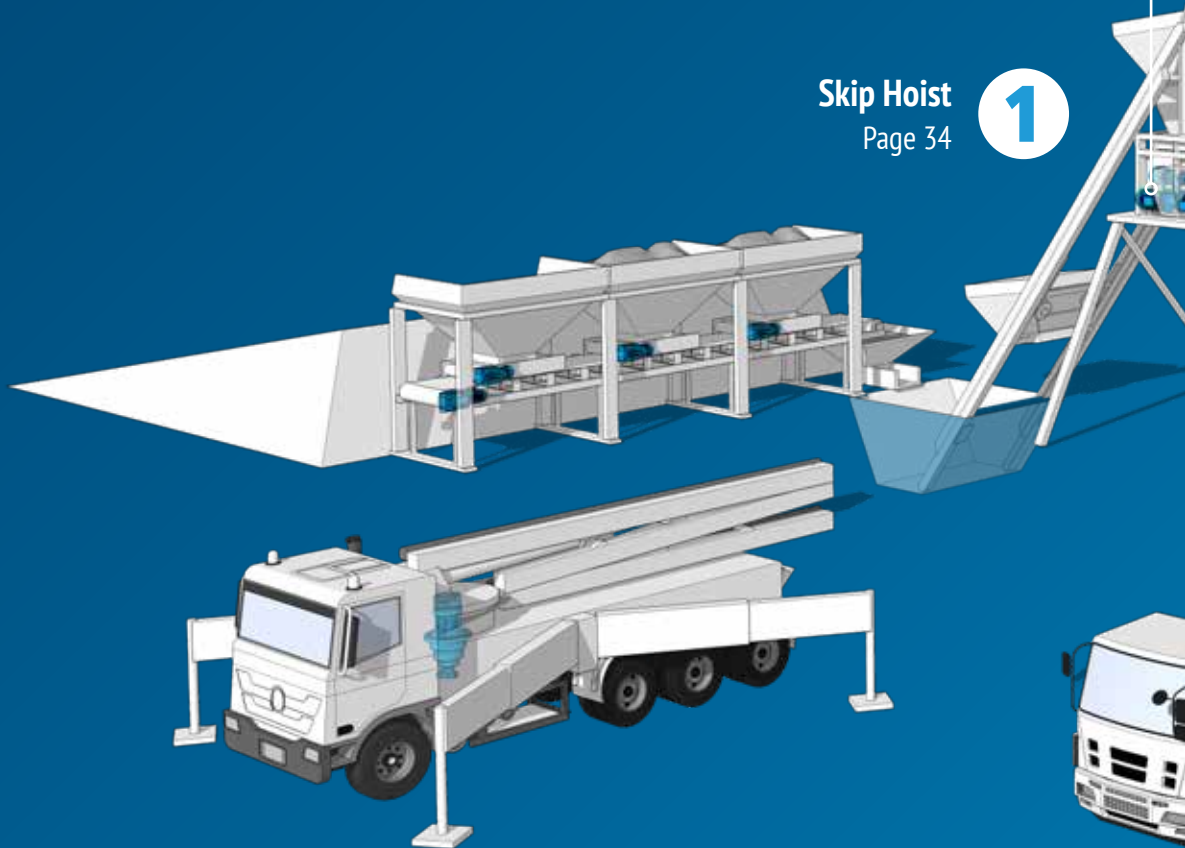

3

Truck-Mounted Concrete Pumps
Page 36

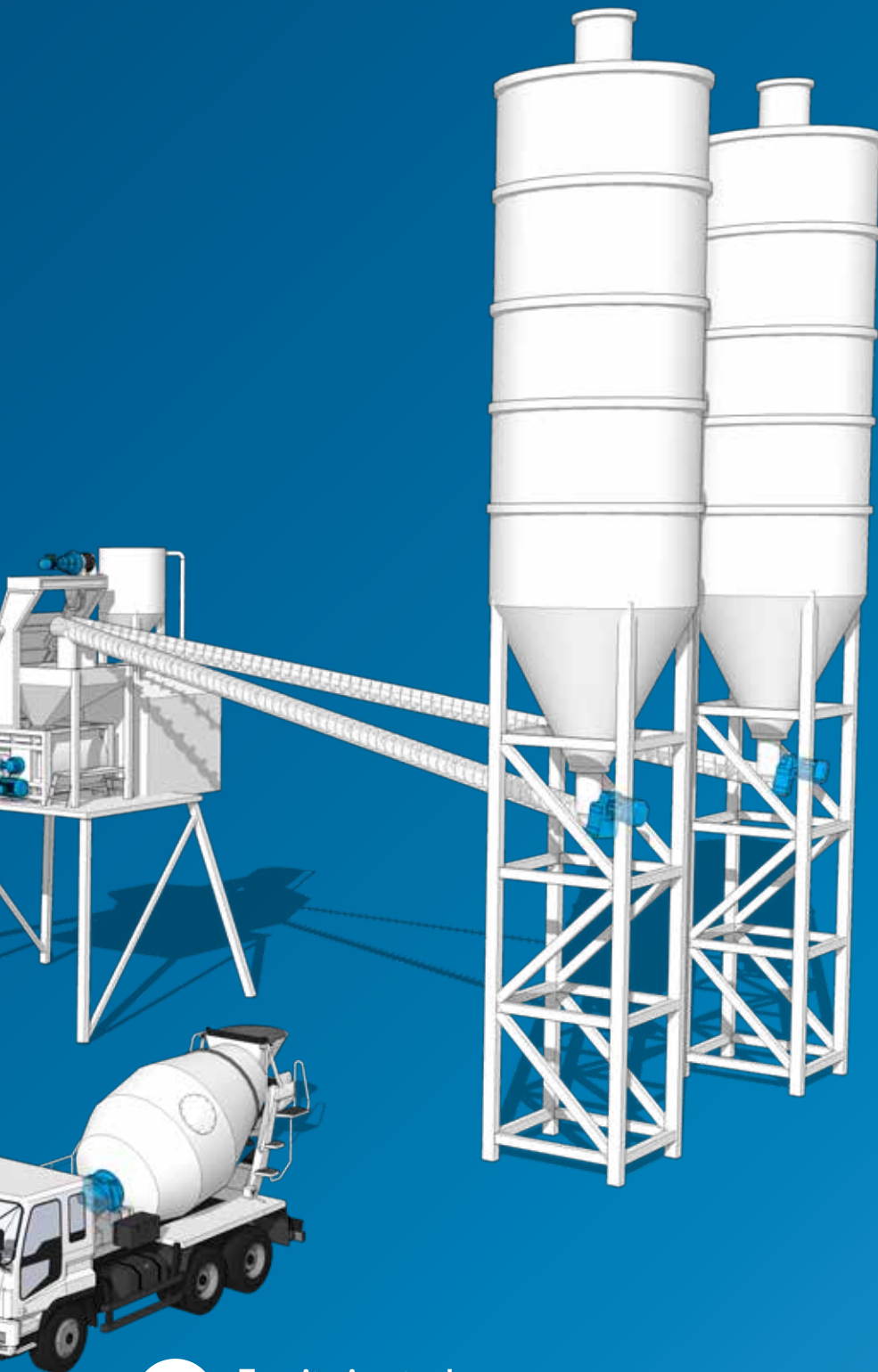

4

Transit mixer trucks

Page 37

Concrete Processes



1

Skip Hoist

Our solutions are perfectly fitting the requirements of any skip hoist allowing to load the bucket with the right quantity of aggregates. The low maintenance as well as the adaptability of our products are critical for this process.

Main Drive

300M Series

Planetary gearbox and geared motor

Output torque

- 1,250 ... 1,286,700 Nm

Gear ratios

- 3.4 ... 2,916

Benefits

- High radial load
- Easy integration with machine
- Flexibility in type of motor selection
- One-stop-shop for a complete drive solution

Features

- Brakemotor
- Reinforced Bearings
- Hydraulic or electric motor input solution
- Wide range of output shaft options



Inverters

Active Cube Series

Premium Inverter

Benefits

- Compact design
- Cost-saving
- Plug & play solution
- Standard cooling and optional water-cooling
- Tropicalized for harsh environment

Features

- Keypad for easy setup, commissioning, parameterization, copy function and diagnosis
- Interface for communication with PC
- Field bus communication: I/O Extension
- Encoder & feedback evaluation
- PC software





2

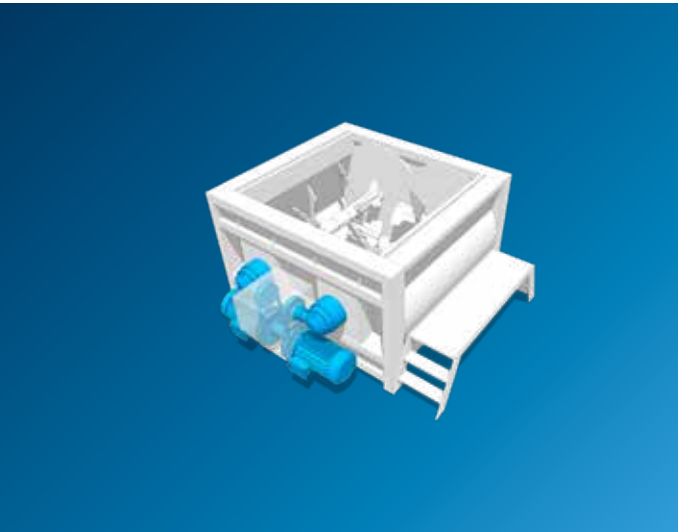

Concrete Mixer

Mixer drives

Bonfiglioli's highly versatile solutions fit these heavy duty applications excellently, helping the machines to deliver optimal mixing results.

Main Drive 300M Series Planetary gearbox and geared motor

Output torque

- 1,250 ... 1,286,700 Nm

Gear ratios

- 3.4 ... 2,916

Benefits

- Compact design
- One-stop-shop for a complete drive solution
- High flexibility in layout and mounting positions
- High resistance in harsh & dusty ambient conditions
- Cost effective

Features

- High Torque Density
- Up to 355kW Motor Power
- Belt Pulley Configuration
- Up to IE3 Efficiency
- Splined male shaft available



Inverters Active Cube Series Premium Inverter

Benefits

- Compact design
- Cost-saving
- Plug & play solution
- Standard cooling and optional water-cooling
- Tropicalized for harsh environment

Features

- Keypad for easy setup, commissioning, parameterization, copy function and diagnosis
- Interface for communication with PC
- Field bus communication: I/O Extension
- Encoder & feedback evaluation
- PC software



Concrete Processes



Truck-Mounted Concrete Pumps 3

Slew drives

Bonfiglioli slew drives provide the safest, most effective solution for truck-mounted concrete pumps. Our products' flexibility matches the versatility of this typical application, allowing the highest reach and the best maneuverability.

Slew drives

700T Series

Hydraulic and Electric solutions

Output torque

- 3,500 ... 35,000 Nm

Gear ratios

- 20 ... 200

Benefits

- Safe & Efficient solutions
- Robustness
- Adaptability
- High torque capacity

Features

- Flange mounted
- Output shaft: splined or with integral pinion
- Rugged construction
- Notchless ground tooth root
- Integrated disc-brake
- High availability by highest teeth and production quality





4

Transit mixer trucks

Drum drives

Our solutions improve concrete trucks' key features, such as precision of rpm control, noise levels and fuel consumption, and reduce maintenance costs. Available in both electric and hydraulic versions, Bonfiglioli drum drives meet machine builders' needs excellently. The electric version not only guarantees greater energy efficiency and reduced fuel consumption, but also helps cut cement mixer truck operating costs.



Drum drives 500 Series Electric solutions

Output torque

- 60,000 Nm

Gear ratios

- Main: 1:220
- Emergency: 1:2200

Benefits

- Improved precision of rpm control
- Less noise levels & fuel consumption
- Reduced maintenance costs
- Energy efficiency

Features

- Rugged design
- High torque capacity
- High load capacity
- Mounting frame for water tank
- Speed sensor

500 Series Hydraulic solutions

Output torque

- 3,000 ... 75,000 Nm

Gear ratios

- 17 ... 161

Benefits

- Compact design
- High torque capacity
- Rugged design

Features

- Rotating housing flange with studs to fit wheels and drums
- Mechanical lifetime seals
- Optional mechanical gear disengagement on request



Asphalt Plant

Cold Feeder
Page 40

1

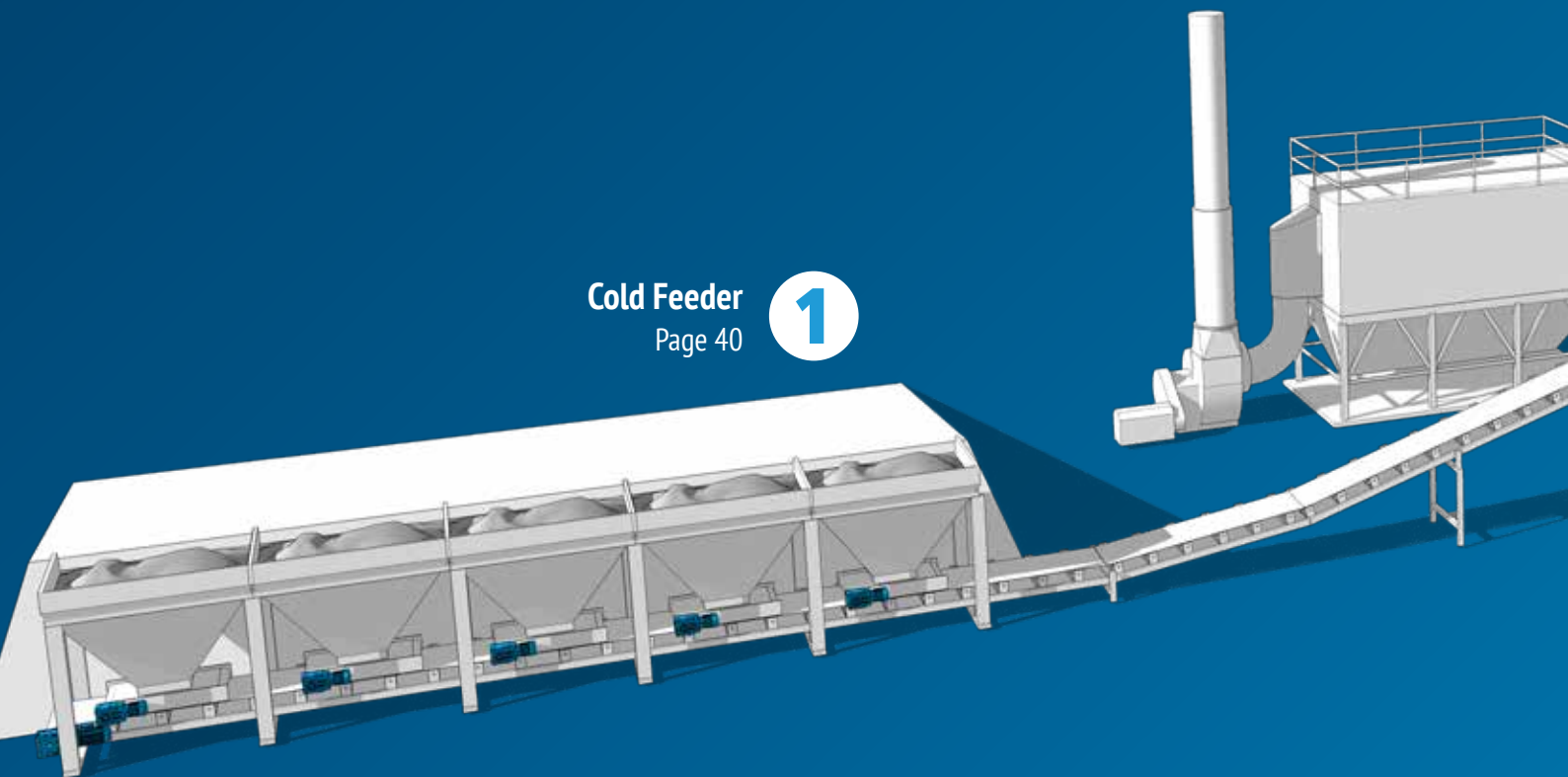

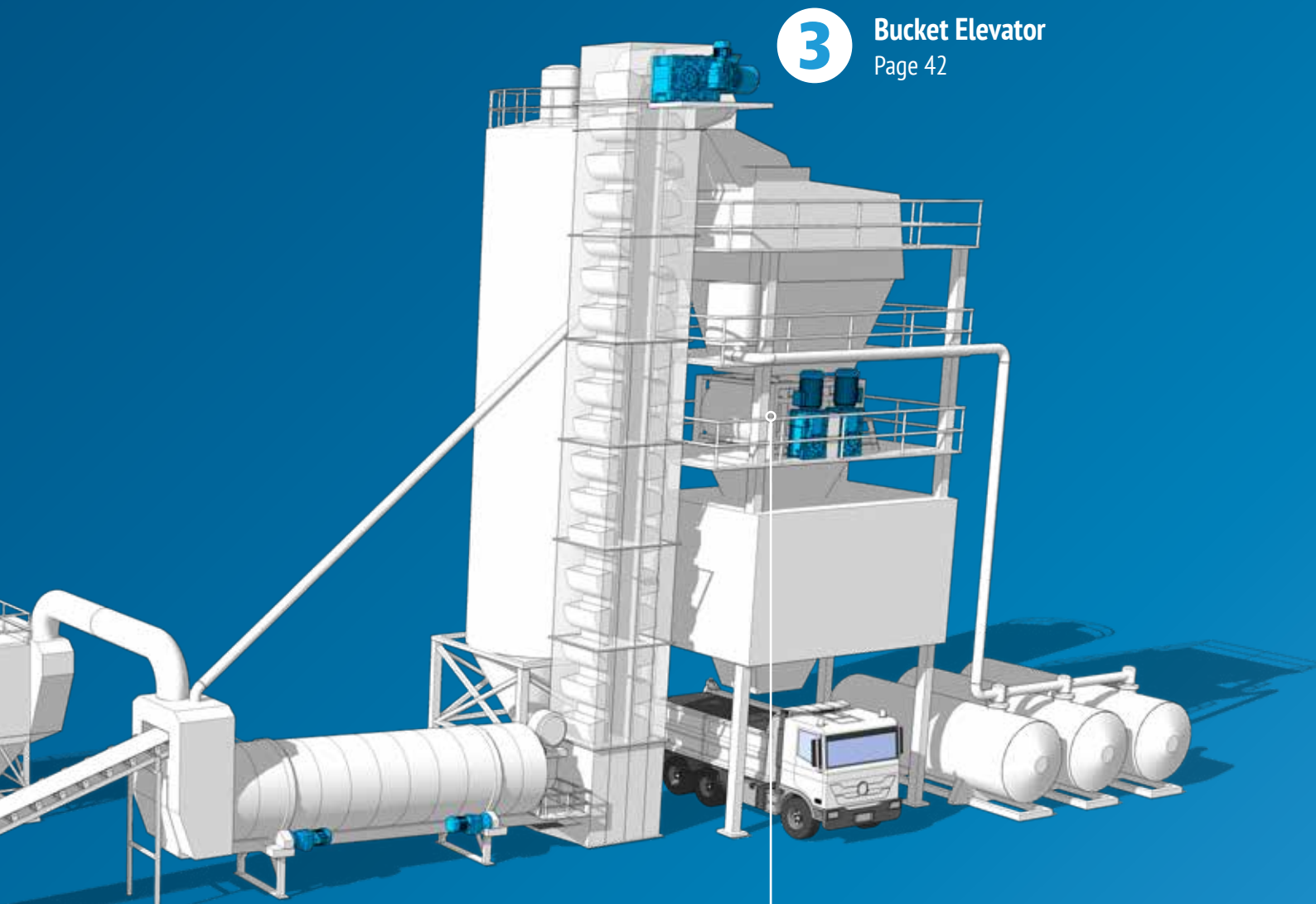

3 Bucket Elevator
Page 42

2 Drying Drum
Page 41

4 Asphalt Mixer
Page 43

Asphalt Plant

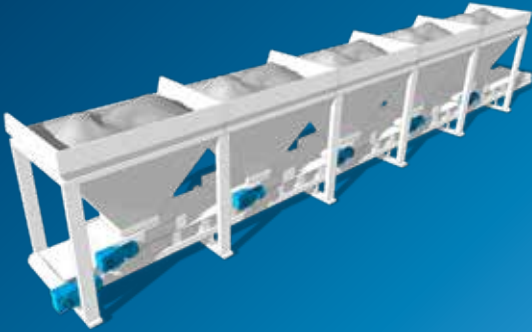

1

Cold Feeder

Adapting the ratio of raw materials, changing the opening size of each bin's gate or adjusting the belt conveyor speed are critical actions our products are able to do for cold feeders.

Belt Conveyor Drive

A Series

Helical bevel geared motor

Output torque

- 100 ... 14,000 Nm

Gear ratios

- 4.9 ... 1,715

Benefits

- Cost Effective
- Easy integration with machine
- Mounting flexibility
- Compactness

Features

- Compact gearmotor
- Right angle layout
- Wide range of mounting option
- Inverter duty motors



Standard gearboxes and geared motors features for construction applications

Taconite seals, C4 or C5 surface protection according to ISO 12944-2, oil heaters, greasers and sensors. Heavy duty oil breather, IP56 degree of protection, thermal protective devices (thermistors and thermostats), anti condensate heaters.

Inverters

Active Cube Series

Premium Inverter

Benefits

- Compact design
- Cost-saving
- Plug & play solution
- Standard cooling and optional water-cooling
- Tropicalized for harsh environment

Features

- Keypad for easy setup, commissioning, parameterization, copy function and diagnosis
- Interface for communication with PC
- Field bus communication: I/O Extension
- Encoder & feedback evaluation
- PC software





2

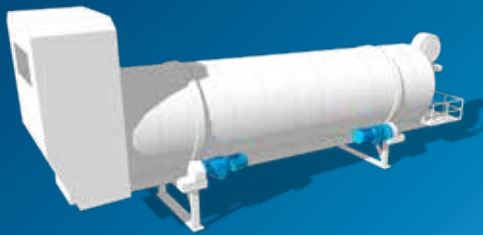

Drying Drum

We offer solutions that adapt to the drum dimensions and design giving thus the opportunity to perfectly manage the intensity of the dryers.

Main Drive

F Series

Shaft mounted geared motor

Output torque

- 140 ... 14,000 Nm

Gear ratios

- 6.4 ... 2,099

Benefits

- Space effective solution and drum clearance
- Reliable operation in hot environment
- Easy installation
- High radial load

Features

- Shaft mounting
- Keyed hollow shaft - two bore options per size, keyless shrink disc fitting (metric series)
- Reinforced Bearings on output shaft
- Thermal protection (bi-metallic, PTC or KTY)



Inverters

Active Cube Series

Premium Inverter

Benefits

- Compact design
- Cost-saving
- Plug & play solution
- Standard cooling and optional water-cooling
- Tropicalized for harsh environment

Features

- Keypad for easy setup, commissioning, parameterization, copy function and diagnosis
- Interface for communication with PC
- Field bus communication: I/O Extension
- Encoder & feedback evaluation
- PC software



Standard gearboxes and geared motors features for construction applications

Taconite seals, C4 or C5 surface protection according to ISO 12944-2, oil heaters, greasers and sensors. Heavy duty oil breather, IP56 degree of protection, thermal protective devices (thermistors and thermostats), anti condensate heaters.

Asphalt Plant



3

Bucket Elevator

The range of products we offer for bucket elevators are matching the requirements of low maintenance, speed control and high shock resistance.

Main Drive

HDO Series

Heavy duty geared motor
(Helical-Bevel)

Output torque

- 8,990 ... 209,000 Nm

Gear ratios

- 5.6 ... 490

Benefits

- Two speeds operation simplify maintenance
- High transmissible power
- Safe operation
- One-stop-shop for a complete drive solution
- Smooth start/stop

Features

- Auxiliary inch drive with self engaging clutch
- Backstop device
- Flexible coupling available
- Up to 355kW Motor Power
- Up to IE3 Efficiency



Auxiliary Drive

A Series

Helical bevel geared motor

Output torque

- 100 ... 14,000 Nm

Gear ratios

- 4.9 ... 1,715

Benefits

- Two speeds operation simplify maintenance
- High transmissible power
- Safe operation
- One-stop-shop for a complete drive solution
- Smooth start/stop

Features

- Auxiliary inch drive with self engaging clutch
- Backstop device
- Flexible coupling available
- Up to 355kW Motor Power
- Up to IE3 Efficiency



Inverters

Active Cube Series Premium Inverter

Benefits

- Compact design
- Cost-saving
- Plug & play solution
- Standard cooling and optional water-cooling
- Tropicalized for harsh environment

Features

- Keypad for easy setup, commissioning, parameterization, copy function and diagnosis
- Interface for communication with PC
- Field bus communication: I/O Extension
- Encoder & feedback evaluation
- PC software



Standard gearboxes and geared motors features for construction applications

Taconite seals, C4 or C5 surface protection according to ISO 12944-2, oil heaters, greasers and sensors. Heavy duty oil breather, IP56 degree of protection, thermal protective devices (thermistors and thermostats), anti condensate heaters.



4

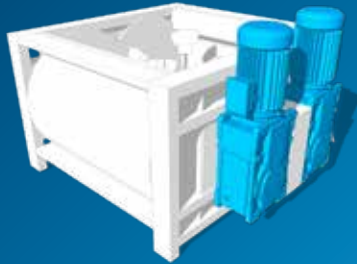

Asphalt Mixer

Bonfiglioli heavy-duty solutions are resistant to long running hours allowing the perfecting movement of the paddles inside the asphalt mixer.

Main Drive HDO Series Heavy duty geared motor (Helical-Bevel)

Output torque

- 8,990 ... 209,000 Nm

Gear ratios

- 5.6 ... 490

Benefits

- High transmissible power
- Compact layout
- Easy mixer shafts synchronization
- One-stop-shop for a complete drive solution
- Easy integration with machine

Features

- 2nd input shaft option
- Motor-Gearbox direct coupling
- Up to 355kW Motor Power
- Up to IE3 Efficiency
- Rain Canopy option for vertical mounting



Standard gearboxes and geared motors features for construction applications

Taconite seals, C4 or C5 surface protection according to ISO 12944-2, oil heaters, greasers and sensors. Heavy duty oil breather, IP56 degree of protection, thermal protective devices (thermistors and thermostats), anti condensate heaters.

Inverters Active Cube Series Premium Inverter

Benefits

- Compact design
- Cost-saving
- Plug & play solution
- Standard cooling and optional water-cooling
- Tropicalized for harsh environment

Features

- Keypad for easy setup, commissioning, parameterization, copy function and diagnosis
- Interface for communication with PC
- Field bus communication: I/O Extension
- Encoder & feedback evaluation
- PC software



Cement Plant

Crusher HPGR
Page 47

2

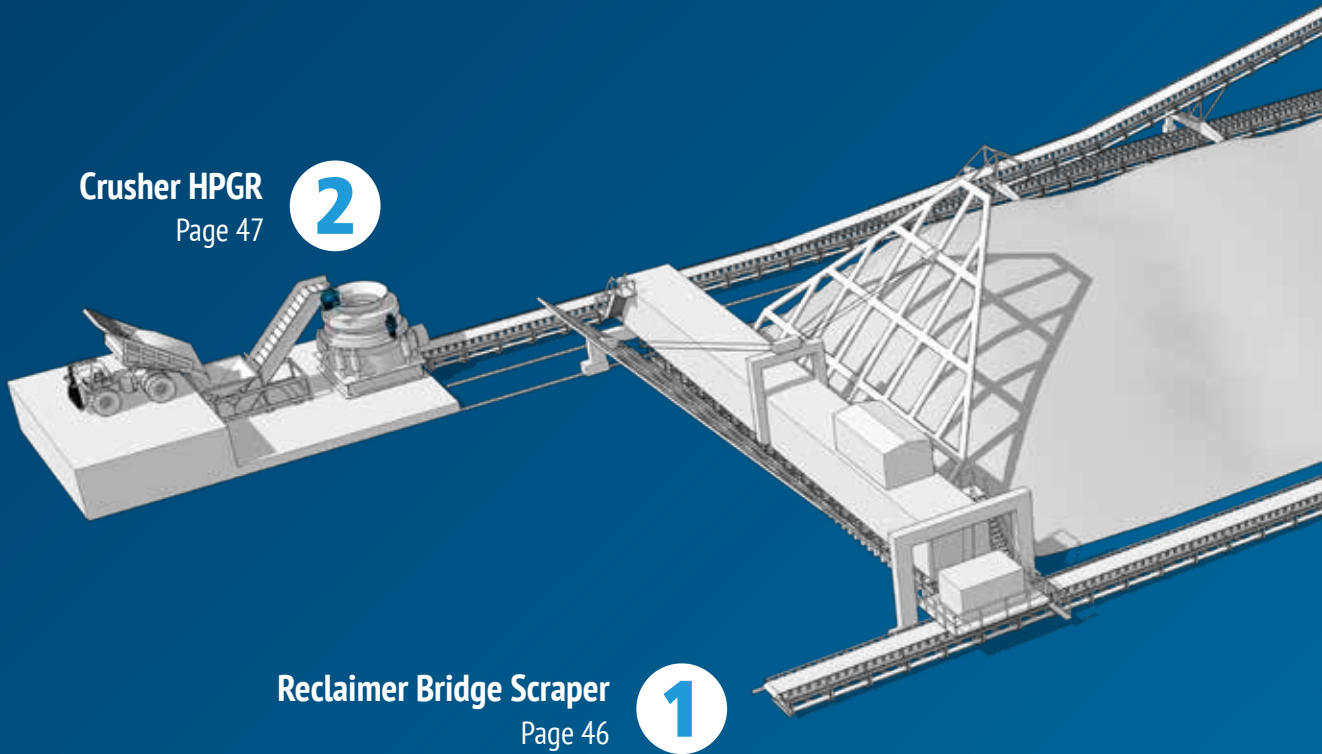

Reclaimer Bridge Scraper
Page 46

1

Mineral Sizer
Page 48

3

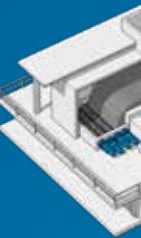

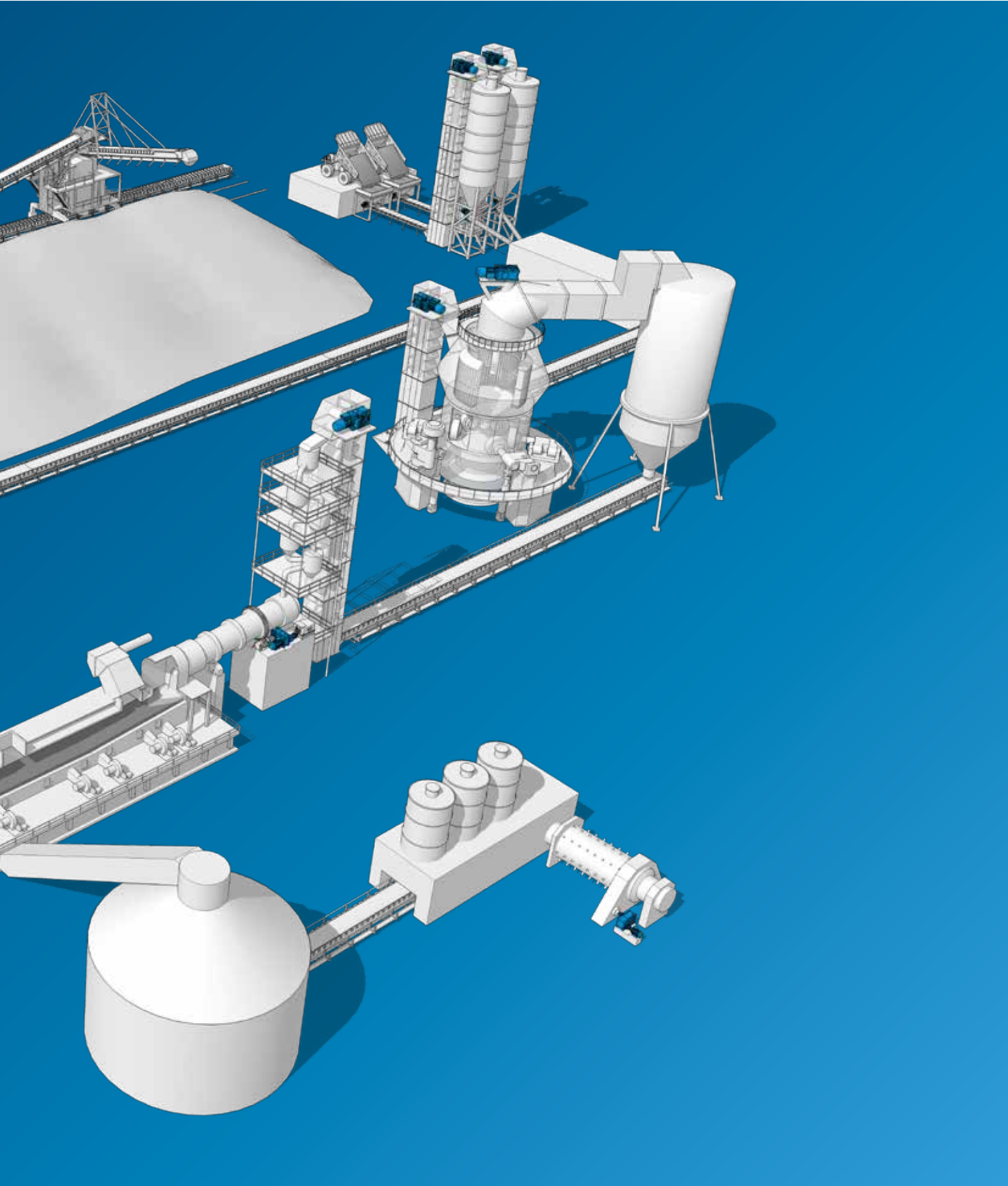

Cement Plant

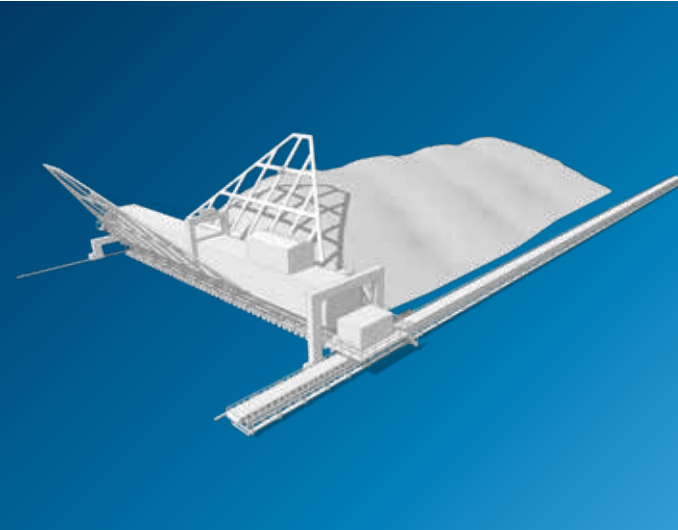

1

Reclaimer Bridge Scraper

The homogenization and the blending of the raw material is a critical phase in the cement plant process. Our solutions are adapted to the specific requirements of bridge reclaimers allowing the material to be conveying to the next stage.

Long Travel Drive & Towing Blades Drive

300M Series

Planetary gearbox and geared motor

Output torque

- 1,250 ... 1,286,700 Nm

Gear ratios

- 3.4 ... 2,916

Benefits

- Compactness
- Wide selection of output speeds
- Cost effective
- Low maintenance
- High resistance in harsh & dusty ambient conditions

Features

- High Torque density
- Modular design
- Wide ratios range
- Shaft mounting with torque arm option



Standard gearboxes and geared motors features for construction applications

Taconite seals, C4 or C5 surface protection according to ISO 12944-2, oil heaters, greasers and sensors. Heavy duty oil breather, IP56 degree of protection, thermal protective devices (thermistors and thermostats), anti condensate heaters.

Inverters

Active Cube Series

Premium Inverter

Benefits

- Compact design
- Cost-saving
- Plug & play solution
- Standard cooling and optional water-cooling
- Tropicalized for harsh environment

Features

- Keypad for easy setup, commissioning, parameterization, copy function and diagnosis
- Interface for communication with PC
- Field bus communication: I/O Extension
- Encoder & feedback evaluation
- PC software





2



Crusher HPGR

Bonfiglioli range of products allows high-pressure grinding crushers to be more than ever energy efficient, reliable and flexible offering thus a resistant cost-saving solution.

Main Drive HDO/HDP Series Heavy duty geared motor (Helical-Bevel/Parallel)

Output torque

- 7,060 ... 209,000 Nm

Gear ratios

- 5.6 ... 500

Benefits

- Compact layout solution
- Easy gearbox installation (shaft mounting option)
- Highly transmissible power
- Cooling-system free
- Wide range of temperature & working condition

Features

- 14 gearbox sizes
- Modular design
- Torque up to 210 000 Nm



Standard gearboxes and geared motors features for construction applications

Taconite seals, C4 or C5 surface protection according to ISO 12944-2, oil heaters, greasers and sensors. Heavy duty oil breather, IP56 degree of protection, thermal protective devices (thermistors and thermostats), anti condensate heaters.

Inverters Active Cube Series Premium Inverter

Benefits

- Compact design
- Cost-saving
- Plug & play solution
- Standard cooling and optional water-cooling
- Tropicalized for harsh environment

Features

- Keypad for easy setup, commissioning, parameterization, copy function and diagnosis
- Interface for communication with PC
- Field bus communication: I/O Extension
- Encoder & feedback evaluation
- PC software



Cement Plant

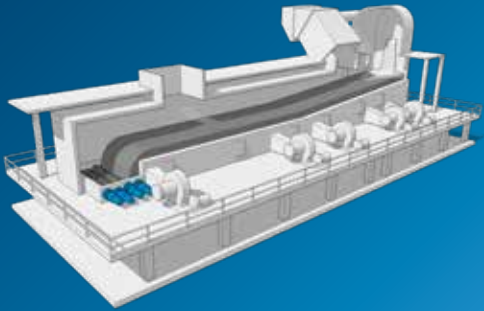

3

Mineral Sizer for Clinker Cooler

Responsible for the movement / rotation of the crushing rollers our products are resistant to shocks, easy to integrate and also allow to extend the life of the mineral sizer.

Main Drive

300M Series

Planetary gearbox and geared motor

Output torque

- 1,250 ... 1,286,700 Nm

Gear ratios

- 3.4 ... 2,916

Benefits

- High Shock resistance
- Compact solution
- Easy integration with machine
- Extended lifetime and reliability

Features

- Bearings with high load
- Increased bearing load capability
- Wide range of output shaft options
- Up to 355kW Motor Power
- Up to IE3 Efficiency



Standard gearboxes and geared motors features for construction applications

Taconite seals, C4 or C5 surface protection according to ISO 12944-2, oil heaters, greasers and sensors. Heavy duty oil breather, IP56 degree of protection, thermal protective devices (thermistors and thermostats), anti condensate heaters.

Inverters

Active Cube Series

Premium Inverter

Benefits

- Compact design
- Cost-saving
- Plug & play solution
- Standard cooling and optional water-cooling
- Tropicalized for harsh environment

Features

- Keypad for easy setup, commissioning, parameterization, copy function and diagnosis
- Interface for communication with PC
- Field bus communication: I/O Extension
- Encoder & feedback evaluation
- PC software





Global Presence



Bonfiglioli is a market force with a presence spanning 22 countries on 5 continents. Our organization makes the most of geographic proximity to offer complete solutions combining efficiency and competence.



3700
EMPLOYEES



22
BRANCHES



14
PLANTS



550
DISTRIBUTORS



80
COUNTRIES

We Are a Global Company

Thanks to an international network of sales branches and closely interconnecting production plants, we can guarantee the same high standards of Bonfiglioli quality anywhere at any given time. Aware that our direct presence in local markets is the key to long-lasting success, our family includes 22 sales branches, 14 production plants and more than 500 distributors around the world.

Our organization is always close by, offering complete and efficient solutions and supporting our customers with dedicated services, such as co-engineering or after-sales assistance.



Bonfiglioli Worldwide Locations

Australia

www.bonfiglioli.com.au
2, Cox Place Glendenning NSW 2761
Locked Bag 1000 Plumpton NSW 2761
Tel. +61 2 8811 8000

Brazil

www.bonfigliolidobrasil.com.br
Travessa Cláudio Armando 171 - Bloco 3 - CEP 09861-730
Bairro Assunção - São Bernardo do Campo - São Paulo
Tel. +55 11 4344 2322

China

www.bonfiglioli.cn
Bonfiglioli Drives (Shanghai) Co., Ltd.
#68, Hui-Lian Road, QingPu District,
201707 Shanghai
Tel. +86 21 6700 2000

France

www.bonfiglioli.fr
14 Rue Eugène Pottier
Zone Industrielle de Moimont II - 95670 Marly la Ville
Tel. +33 1 34474510

Germany

www.bonfiglioli.de
Bonfiglioli Deutschland GmbH
Sperberweg 12 - 41468 Neuss
Tel. +49 0 2131 2988 0

Bonfiglioli Vectron

Europark Fichtenhain B6 - 47807 Krefeld
Tel. +49 0 2151 8396 0

O&K Antriebstechnik

Ruhrallee 8-12 - 45525 Hattingen
Tel. +49 0 2324 2050 1

India

www.bonfiglioli.in
Bonfiglioli Transmissions Pvt. Ltd.
Plot No. AC7-AC11, SIDCO Industrial Estate,
Thirumudivakkam - 600 044 Chennai
Tel. +91 44 2478 1035

Industrial

Survey No. 528, Porambakkam High Road,
Mannur Village, Sriperambudur Taluk - 602 105 Chennai
Tel. +91 44 6710 3800
Plot No. A-95, Phase IV, MIDC Chakan, Village Nighoje
Pune, Maharashtra - 410 501

Italy

www.bonfiglioli.it

Headquarters

Bonfiglioli Riduttori S.p.A.
Via Giovanni XXIII, 7/A - 40012 Lippo di Calderara di Reno
Tel. +39 051 647 3111

Mobile, Wind

Via Enrico Mattei, 12 Z.I. Villa Selva - 47100 Forlì
Tel. +39 0543 789111

Industrial

Via Bazzane, 33/A - 40012 Calderara di Reno
Tel. +39 051 6473111
Via Trinità, 1 - 41058 Vignola
Tel. +39 059 768511
Via Sandro Pertini lotto 7b - 20080 Carpiano
Tel. +39 02 985081

Bonfiglioli Mechatronic Research

Via F. Zeni 8 - 38068 Rovereto
Tel. +39 0464 443435/36

New Zealand

www.bonfiglioli.co.nz
88 Hastie Avenue, Mangere Bridge, 2022 Auckland
PO Box 11795, Ellerslie
Tel. +64 09 634 6441

Singapore

www.bonfiglioli.com
24 Pioneer Crescent #02-08
West Park Bizcentral - Singapore, 628557
Tel. +65 6268 9869

Slovakia

www.bonfiglioli.com
Robotnícka 2129
Považská Bystrica, 01701 Slovakia
Tel. +421 42 430 75 64

South Africa

www.bonfiglioli.co.za
55 Galaxy Avenue, Linbro Business Park - Sandton
Tel. +27 11 608 2030

Spain

www.tecnotrans.bonfiglioli.com
Tecnotrans Bonfiglioli S.A.
Pol. Ind. Zona Franca, Sector C, Calle F, nº 6
08040 Barcelona
Tel. +34 93 447 84 00

Turkey

www.bonfiglioli.com.tr
Atatürk Organize Sanayi Bölgesi, 10007 Sk. No. 30
Atatürk Organize Sanayi Bölgesi, 35620 Çiğli - Izmir
Tel. +90 0 232 328 22 77

United Kingdom

www.bonfiglioli.co.uk
Industrial
Unit 7, Colemeadow Road
North Moons Moat - Redditch, Worcestershire B98 9PB
Tel. +44 1527 65022

Mobile, Wind

3 - 7 Grosvenor Grange, Woolston
Warrington - Cheshire WA1 4SF
Tel. +44 1925 852667

USA

www.bonfiglioliusa.com
3541 Hargrave Drive
Hebron, Kentucky 41048
Tel. +1 859 334 3333

Vietnam

www.bonfiglioli.vn
Lot C-9D-CN My Phuoc Industrial Park 3
Ben Cat - Binh Duong Province
Tel. +84 650 3577411



We have a relentless commitment to excellence, innovation and sustainability. Our team creates, distributes and services world-class power transmission and drive solutions to keep the world in motion.

HEADQUARTERS

Bonfiglioli Riduttori S.p.A.
Via Giovanni XXIII, 7/A
40012 Lippo di Calderara di Reno
Bologna (Italy)
www.bonfiglioli.com

