

# Solutions for Mining Industry

Mining



MARKETS &  
APPLICATIONS





# Mining Industry



## Crushing, Grinding & Material Handling

Page 4 to 9



## Slurry Processing

Page 10 to 15



## Earth-Moving Processes

Page 16 to 21

## The broadest range of solutions for the Mining Industry

Thanks to decades of experience in developing customized solutions for the most demanding mining applications around the world, Bonfiglioli is able to offer its customers a wide, complete and adapted range of solutions.

From crushing to slurry processes to earth moving applications, our team of experts is designing and creating integrated solutions that perfectly match the harsh and dusty environments typical of mining applications.

Bonfiglioli final drive, gearbox, geared motor or motion and control solutions are recognized on the market by worldwide leading players, with whom we've been working for decades. Today, our range of products is one of the broadest available in the world, with torque values from 13 Nm to 3,000,000 Nm.

Bonfiglioli also provides solutions for:



EARTH-MOVING MACHINES



MARINE & OFFSHORE



WATER TREATMENT

[www.bonfiglioli.com](http://www.bonfiglioli.com)

### Products for all types of mining equipment:

- Hydraulic shovel excavators
- Electric or hybrid rope shovel excavators
- Bucket wheel excavators
- Dump trucks with diesel-electric driveline
- Crushers and screeners
- Mining stackers
- Belt wagons
- Conveyors - Systems & belt drives
- Conveyors - Systems & mobile transfer drives
- Blast hole drills
- Surface miners
- Underground mining equipment



# Crushing, Grinding & Material Handling

**1** **Crushing**  
Page 6

**2** **Feeding**  
Page 7

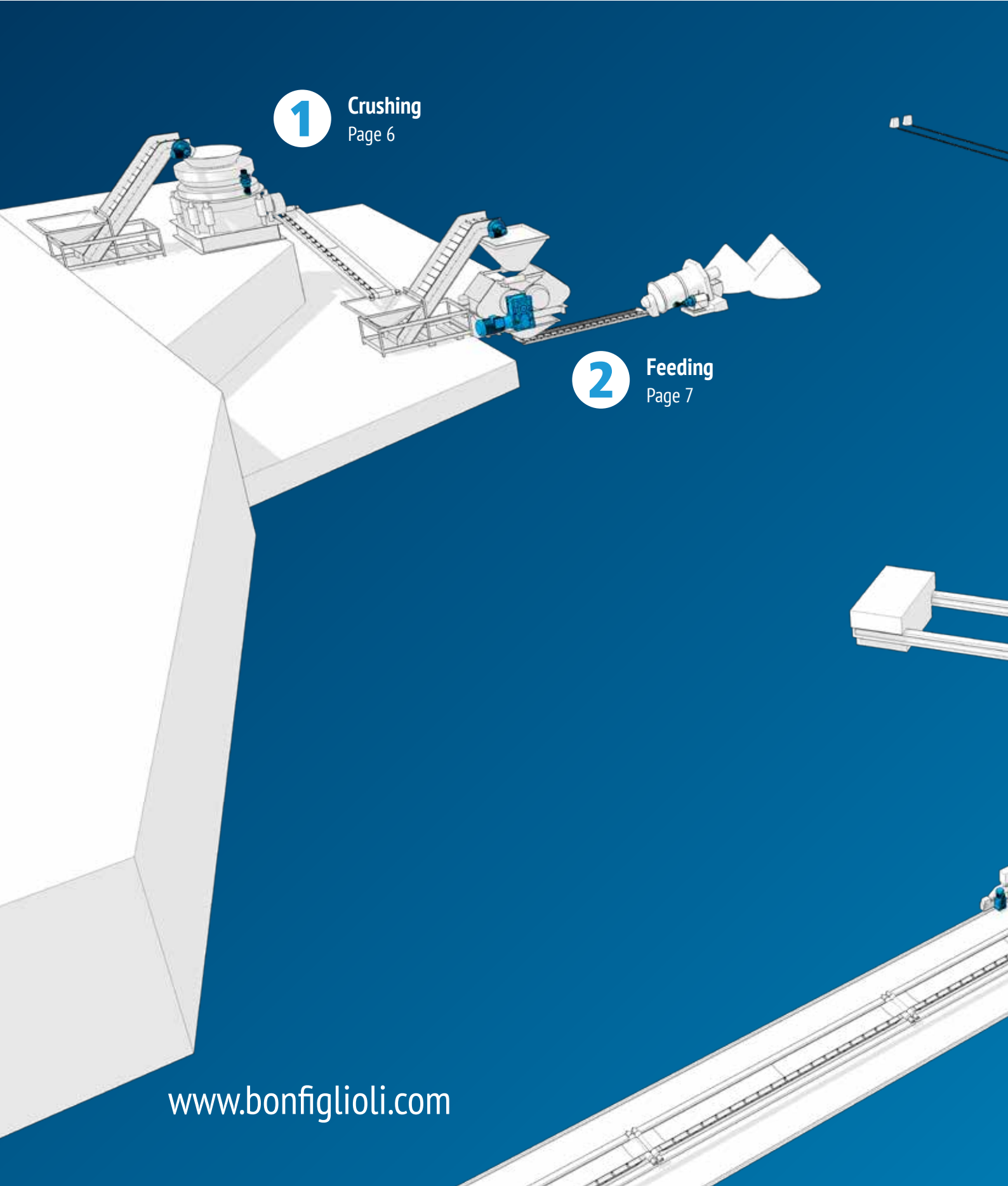



Unloading **4**  
Page 9

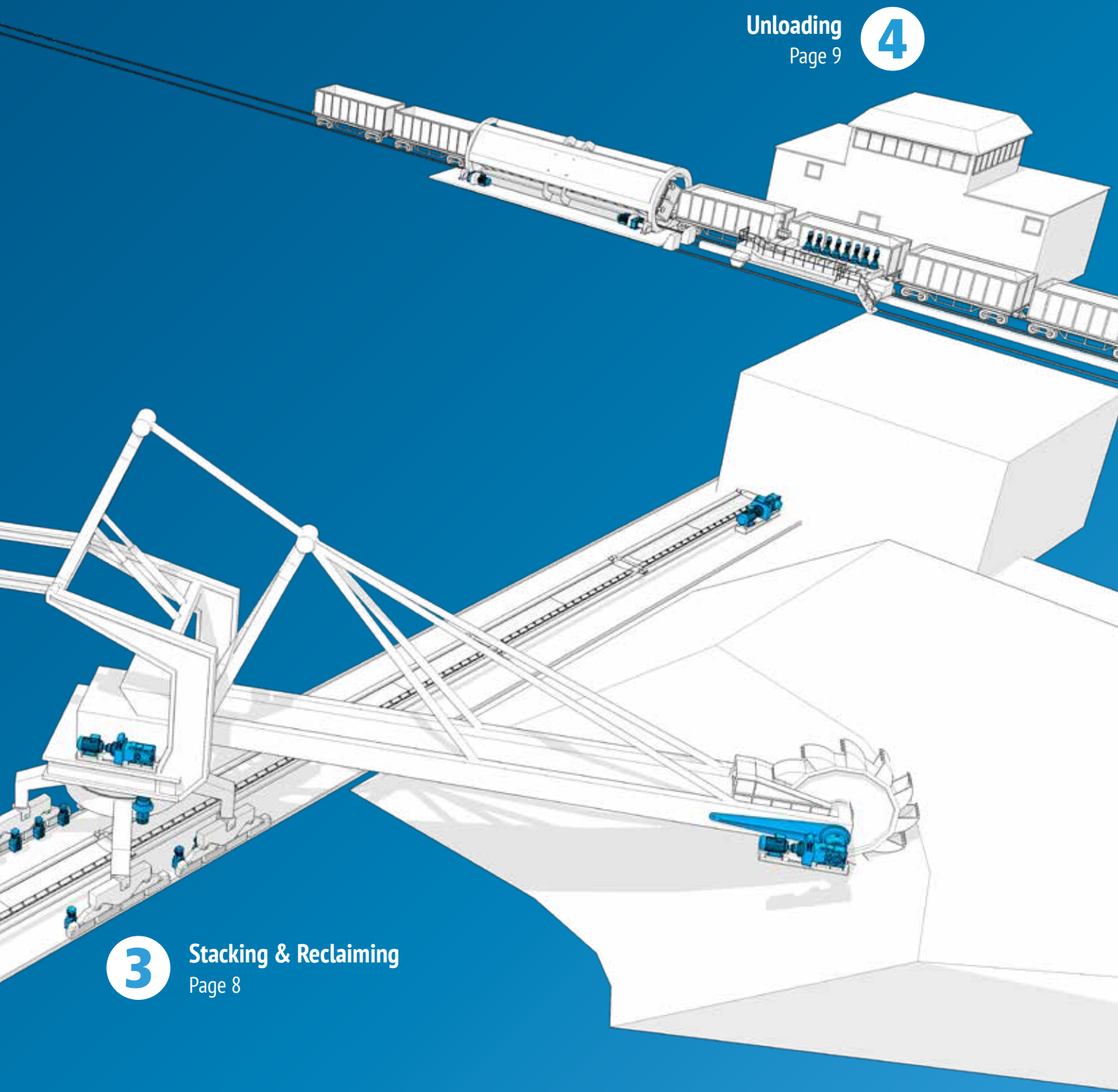

**3** Stacking & Reclaiming  
Page 8

# Crushing, Grinding & Material Handling

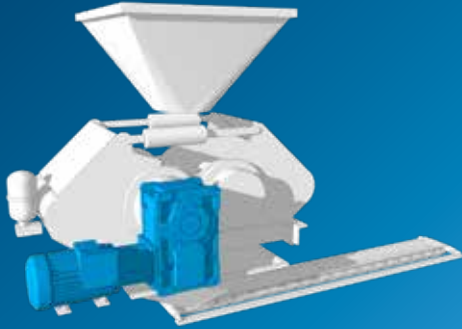

## Crushing

### Crushing & grinding solutions

1

Crushing is a crucial process in the mineral industry, so reliability of the products for these applications must be extremely high to ensure process continuity. Bonfiglioli solutions for crushers are extremely robust and manufactured to the highest quality criteria. Our heavy-duty products for these applications can operate 24/7/365 and ensure maximum operational time. Furthermore, our solution can be customized with torque arms adapted to the machine design and completed with highly corrosion-resistant paints and seals for mining environments.

## Main drive

### HDO/HDP Series

#### Heavy duty gearbox and geared motor

##### Benefits

- Compact layout solution
- Easy gearbox installation (shaft mounting option)
- Highly transmissible power
- Cooling-system free
- Wide range of temperature & working condition

##### Features

- 14 gearbox sizes
- Modular design
- Torque up to 210,000 Nm



#### Standard gearboxes and geared motors features for mining applications:

Taconite seals, C4 or C5 surface protection according to ISO 12944-2, oil heaters, greasers and sensors, heavy duty oil breather, IP56 degree of protection, thermal protective devices (thermistors and thermostats), anti-condensate heaters, tropicalized windings.

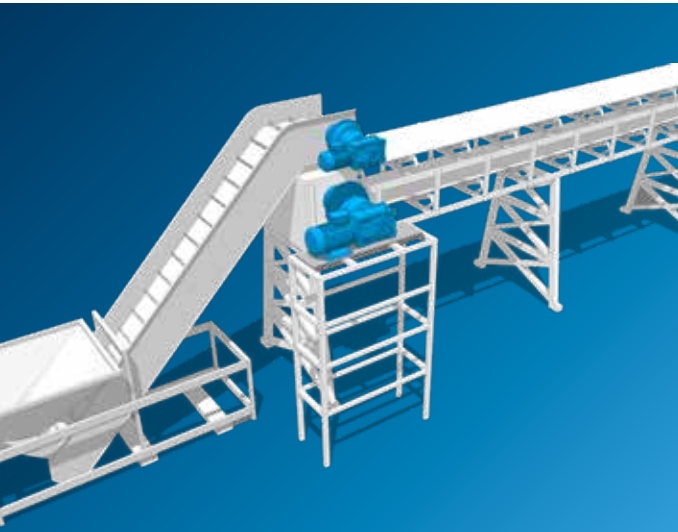

## Feeding

### Feeder & conveyor solutions

2

Bonfiglioli is an expert on issues related to these applications: the high breaking torque required at startup, the high load shocks caused by material drops and the dusty environments in mines are only a few of the challenges that our products can successfully overcome. We can provide complete solutions for feeders and conveyors with integrated base plates and torque arms which are protected against harsh environments with special seals and paints to simplify machine design for our customers.

## Main drive

### HDO Series

#### Heavy duty gearbox and geared motor (Bevel-Helical)

##### Benefits

- One-stop-shop for a complete drive solution
- E-motor alignment free solution & free base frame
- Reliable, free maintenance and integrated cooling system
- Extended lifetime & reliability
- Highly transmissible power

##### Features

- Extended bearing lifetime
- Torque range up to 210,000 Nm
- Strengthened E-motor input flange with integrated fan and coupling
- Wide range of options
- Integrated forced oil lubrication option
- Torque arm, coupling, brake, motor



#### Standard gearboxes and geared motors features for mining applications:

Taconite seals, C4 or C5 surface protection according to ISO 12944-2, oil heaters, greasers and sensors, heavy duty oil breather, IP56 degree of protection, thermal protective devices (thermistors and thermostats), anti-condensate heaters, tropicalized windings.

## Inverters

### Active Cube Series

#### Premium Inverter

##### Benefits

- High power density
- Water cooling provides increased life-time application
- Cost-effective solution

##### Features

- Energy saving functions
- Motor temperature monitoring
- Ready for liquid cooling option



# Crushing, Grinding & Material Handling

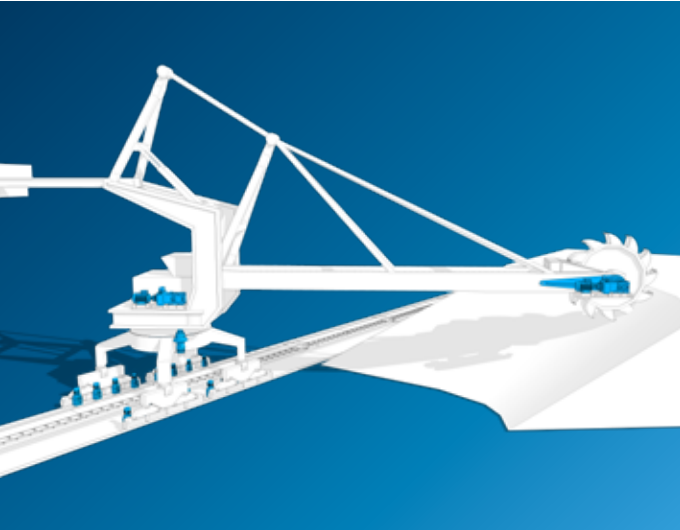

## Stacking & reclaiming Stacker / reclaimer solutions

3

Multi-functional machines, such as stackers/reclaimers, store and gather material in large mining processes. Bonfiglioli can provide solutions for all stacker/reclaimer drives. The products we supply are tailored to match the specific requirements of each machine drive: different brakes, forced lubrication, integrated base plates, cooling fans and oil expansion tanks are just a few examples of how we can meet our customers' needs. Finally, all the solutions can be further customized with a set of features specifically developed to resist the harsh mining environment.

### Slew drive **300M Series** Planetary gearbox and geared motor

#### Benefits

- Hydraulic or electric motor input solution
- Integration with negative brake
- High overload capacity
- Torque control
- Easy installation

#### Features

- Reinforced bearing output shaft
- Eccentric mounting flange option for pinion /girth gear adjustment
- Shock load up to 2,000,000 Nm
- Encoder and integrated load cell
- Base frame, coupling, brake, motor
- Oil expansion tank & oil level switch



### Bucket wheel drive **3/H Series** Gearbox and geared motor

#### Benefits

- One-stop shop for a complete drive solution
- Extended oil service interval
- Maintenance free cooling device solution
- High overload capacity
- Highly transmissible torque and power

#### Features

- Modular design
- Shock load up to 2,000,000 Nm
- Increased bearing load capability
- Wide range of options
- Integrated forced oil lubrication
- Torque arm, base frame, coupling, brake, motor



### Track drive **FP Series**

#### Output torque

- 100 ... 1,100 kNm

#### Gear ratios

- 248 ... 825

#### Benefits

- Compact design
- High torque & load capacity
- Available with failsafe parking brake and for most cartridge type fixed or variable.

#### Features

- Rotating housing
- Rugged design
- Mechanical lifetime seals
- 3-7 Planetary wheels per stage
- Notchless ground tooth root
- Different ratios
- Integrated disc-brake



#### Standard gearboxes and geared motors features for mining applications:

Taconite seals, C4 or C5 surface protection according to ISO 12944-2, oil heaters, greasers and sensors, heavy duty oil breather, IP56 degree of protection, thermal protective devices (thermistors and thermostats), anti-condensate heaters, tropicalized windings.



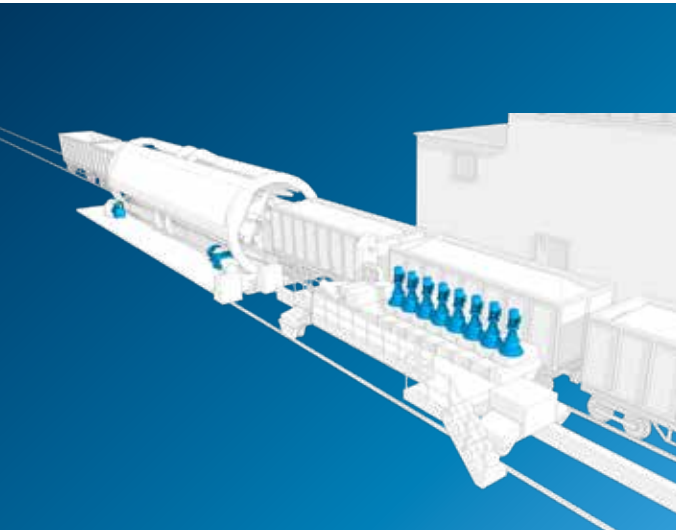

## Unloading Car dumper solutions

4

Unloading procedures in a mining plant are usually done by a train positioner coupled with a wagon tippler.

Bonfiglioli solutions for train positioners have customized gearmotors adapted to the machine design. Furthermore, the products we use in these applications feature special seals.

### Wagon tripler:

Wagon trippers rotate train cars together with the rail section beneath them to unload the material.

## Train positioner drive 300M Series Planetary gearbox and geared motor

### Benefits

- Highly transmissible torque and power
- Compact design
- Cooling-system free
- Integrated brake solution
- Wide range of temperature & working condition

### Features

- New e-motor flange with integrated fan
- Increased bearing load capability
- Dedicated design for disk brake integration
- Nominal torque up to 1,300,000 Nm
- Modular design
- Oil expansion tank & oil level switch



### Standard gearboxes and geared motors features for mining applications:

Taconite seals, C4 or C5 surface protection according to ISO 12944-2, oil heaters, greasers and sensors, heavy duty oil breather, IP56 degree of protection, thermal protective devices (thermistors and thermostats), anti-condensate heaters, tropicalized windings.

## Inverters Active Cube Series Premium Inverter

### Benefits

- High power density
- Water cooling provides increased life-time application
- Cost-effective solution

### Features

- Energy saving functions
- Motor temperature monitoring
- Ready for liquid cooling option



# Slurry Processing

Dewatering  
Page 13

2

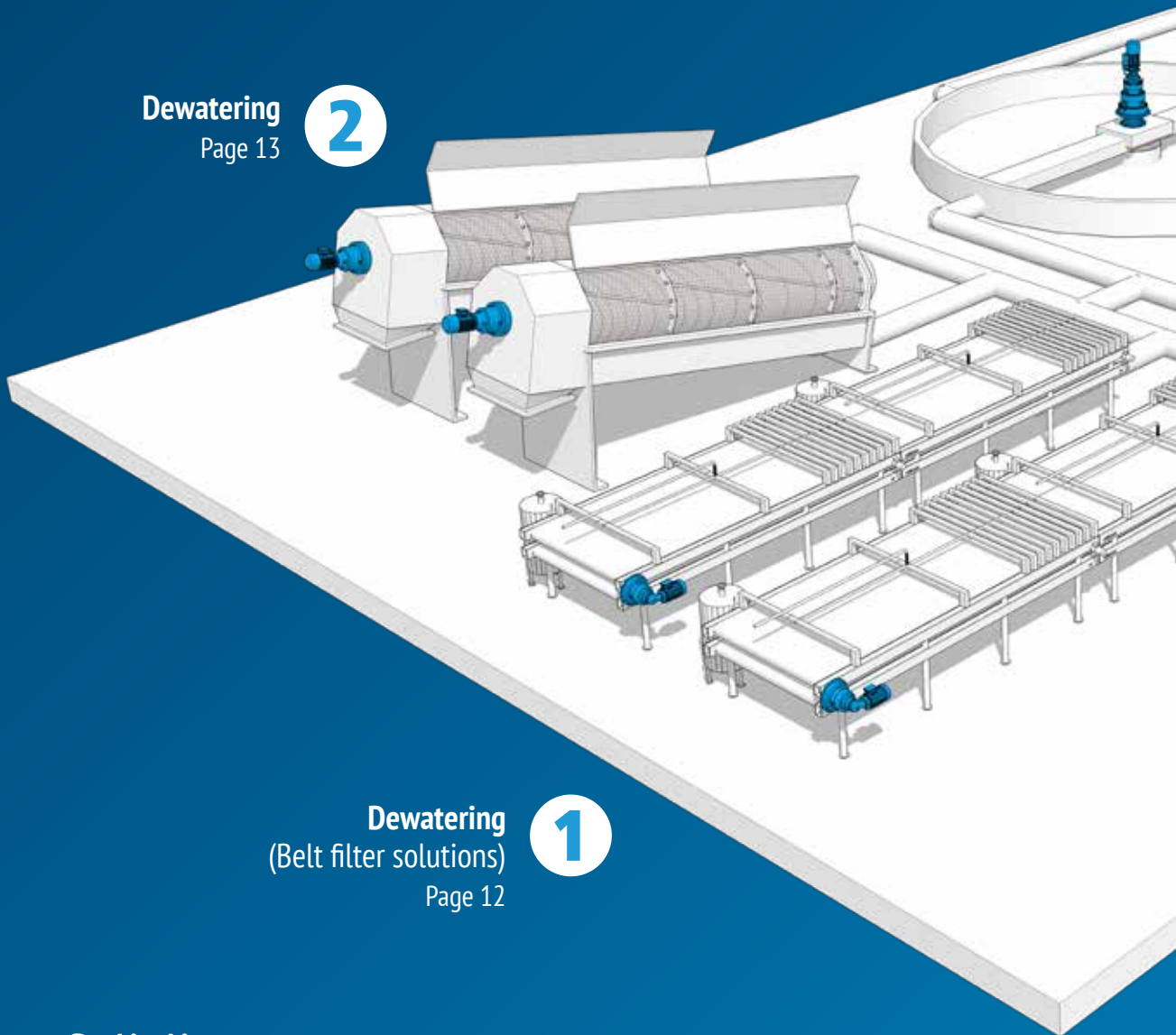

Dewatering  
(Belt filter solutions)  
Page 12

1



**3** Flotation  
Page 14

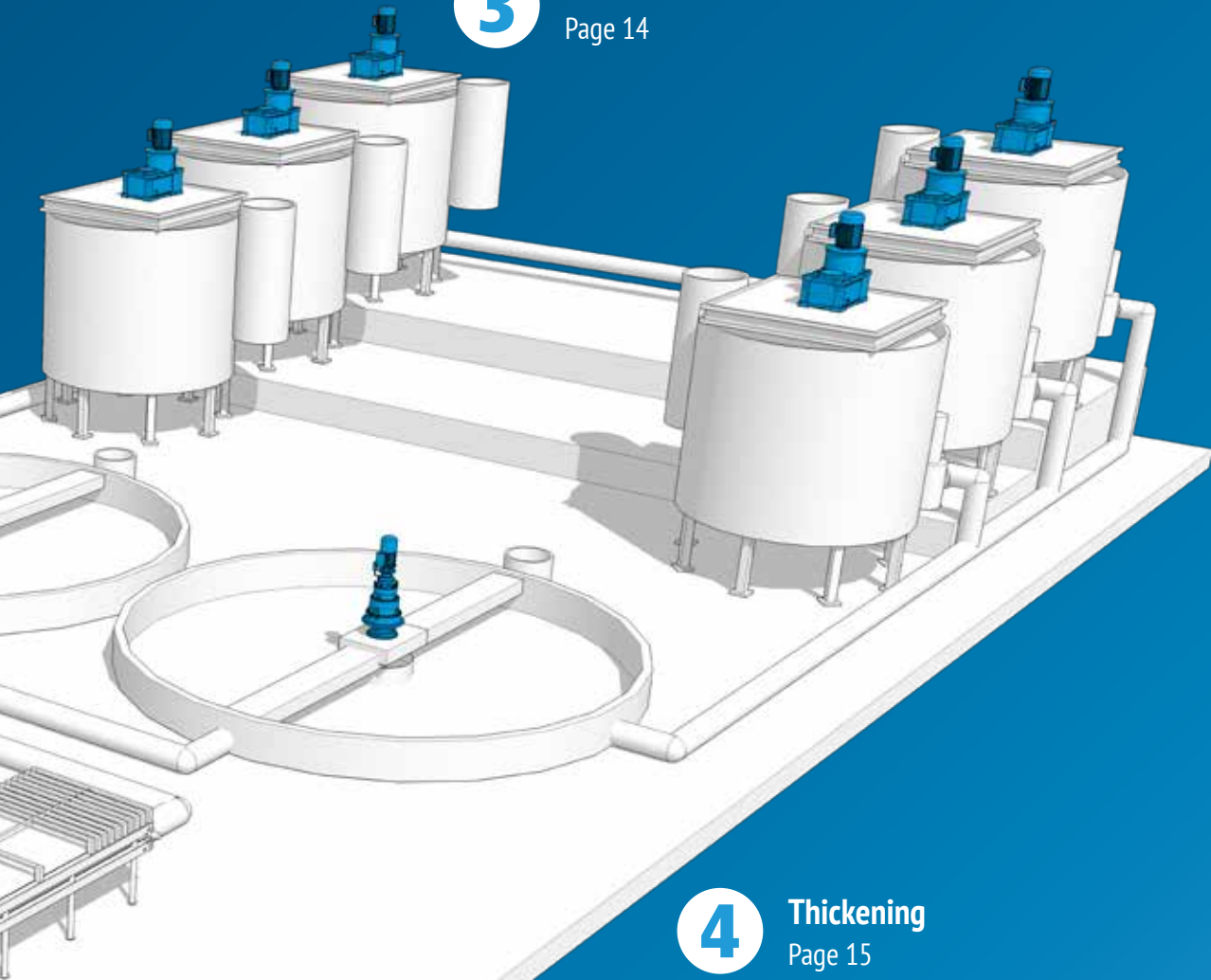

**4** Thickening  
Page 15

# Slurry Processing

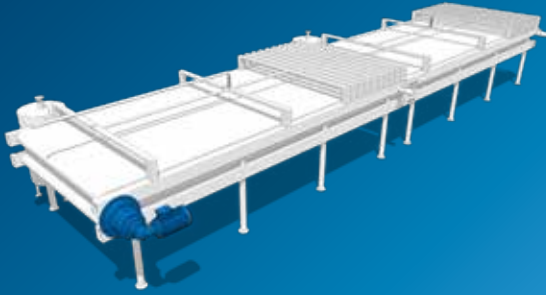

1

## Dewatering Belt filter solutions

Focusing on solid/liquid separation, the belt filter presses the product with mechanical pressure to squeeze the water out of the sludge. Flexibility in layout and mounting positions as well as high resistance in harsh, dusty and ambient conditions are key features that our products can deliver.

### Main drive

## 300M Series

### Planetary gearbox and geared motor

#### Benefits

- One-stop-shop for a complete drive solution
- High flexibility in layout and mounting positions
- High resistance in harsh & dusty ambient conditions
- High torque density
- Wide range of working temperature working conditions

#### Features

- 20 gearbox sizes
- Nominal torque up to 1,300,000 Nm
- Modular design
- Increased bearing load capability
- Shaft gearbox mounting
- Torque arm



#### Standard gearboxes and geared motors features for mining applications:

Taconite seals, C4 or C5 surface protection according to ISO 12944-2, oil heaters, greasers and sensors, heavy duty oil breather, IP56 degree of protection, thermal protective devices (thermistors and thermostats), anti-condensate heaters, tropicalized windings.



2

## Dewatering Spiral classifier solutions

Spiral classifiers are designed to settle and dewater relatively coarse particles from high volume, low percent solid volume streams. Flexibility in layout and mounting positions as well as high resistance in harsh, dusty and ambient conditions are key features that our products can deliver.

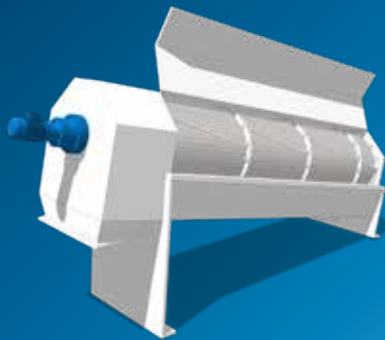

### Main drive **300M Series** Planetary gearbox and geared motor

#### Benefits

- One-stop-shop for a complete drive solution
- High flexibility in layout and mounting positions
- High resistance in harsh & dusty ambient conditions
- High torque density
- Wide range of working temperature working conditions

#### Features

- 20 gearbox sizes
- Nominal torque up to 1,300,000 Nm
- Modular design
- Increased bearing load capability
- Flange gearbox mounting



#### Standard gearboxes and geared motors features for mining applications:

Taconite seals, C4 or C5 surface protection according to ISO 12944-2, oil heaters, greasers and sensors, heavy duty oil breather, IP56 degree of protection, thermal protective devices (thermistors and thermostats), anti-condensate heaters, tropicalized windings.

# Slurry Processing



3

## Flotation

### Flotation cell solutions

Flotation cells mainly consist of big tanks where an impeller keeps the water/material solution rotating at a high speed. For this application, Bonfiglioli provides helical bevel or parallel shaft gearmotors with more bearings. Output configurations are usually reinforced bearings to withstand by the machine impeller on the shaft. In some models, the machine requires injection of high-pressure air to maximize separation of the material from water.

### Main drive

## HDO/HDP Series

### Heavy duty gearbox and geared motor

#### Benefits

- Air flow inlet and through hole prearrangement on output shaft
- Enhanced oil leak protection
- High radial & axial load capability on output shaft
- Extended lifetime & reliability
- Highly transmissible power

#### Features

- Reinforced bearing and extended span on output shaft
- Drywell
- Modular design
- Integrated forced oil lubrication
- Back stop device



#### Standard gearboxes and geared motors features for mining applications:

Taconite seals, C4 or C5 surface protection according to ISO 12944-2, oil heaters, greasers and sensors, heavy duty oil breather, IP56 degree of protection, thermal protective devices (thermistors and thermostats), anti-condensate heaters, tropicalized windings.



4

## Thickening

### Thickener solutions

Separating the minerals from the water using gravity sedimentation means controlling the speed and at the same time facilitating the precise movements. For this application Bonfiglioli offers vertical linear planetary gearboxes with very high reduction ratios to obtain speeds of <1 rpm on the output shaft, with particular attention to possible torque overloads, depending on the solid material layer thickness moved by the rake.

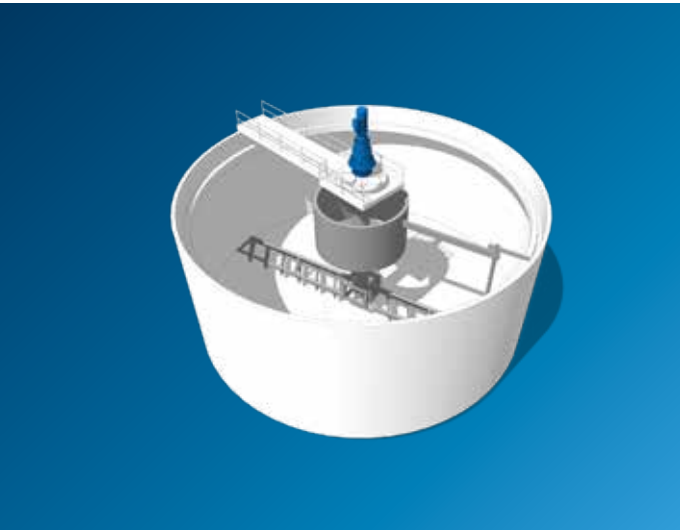

### Main drive

## 300M Series

### Planetary gearbox and geared motor

**Benefits**

- High shock load capability
- Extended lifetime & reliability
- Torque control

**Features**

- Increased bearing load capability
- Integrated load cell
- Modular design
- Shock load up to 2,000,000 Nm
- Oil expansion tank & oil level switch



**Standard gearboxes and geared motors features for mining applications:**

Taconite seals, C4 or C5 surface protection according to ISO 12944-2, oil heaters, greasers and sensors, heavy duty oil breather, IP56 degree of protection, thermal protective devices (thermistors and thermostats), anti-condensate heaters, tropicalized windings.

### Inverters

## Active Cube Series

### Premium Inverter

**Benefits**

- High power density
- Water cooling provides increased life-time application
- Cost-effective solution

**Features**

- Energy saving functions
- Motor temperature monitoring
- Ready for liquid cooling option



# Earth-Moving Machines

Bucket wheel excavators

Page 20

3

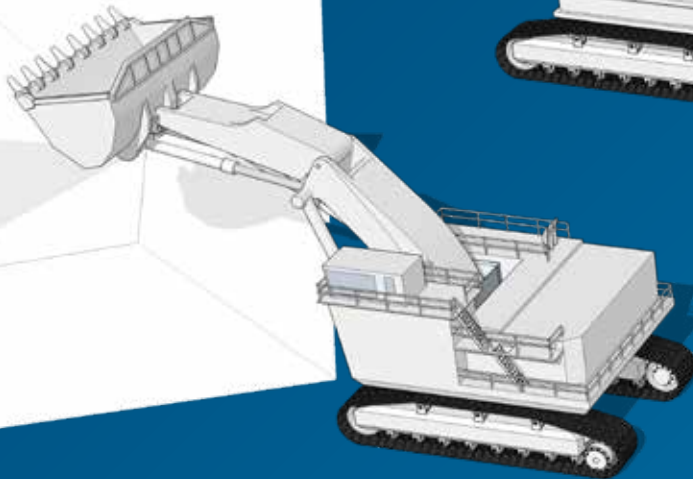
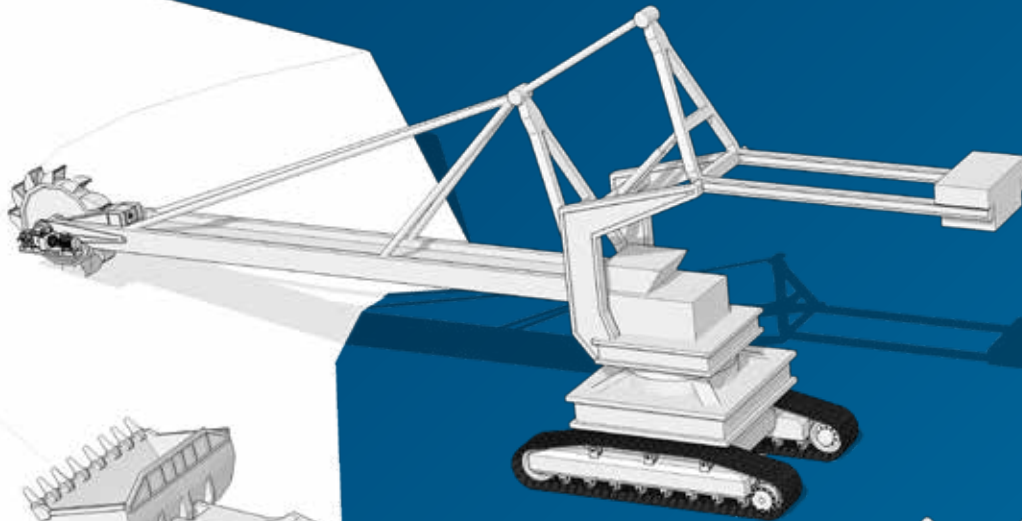

Large excavators

Page 18

1

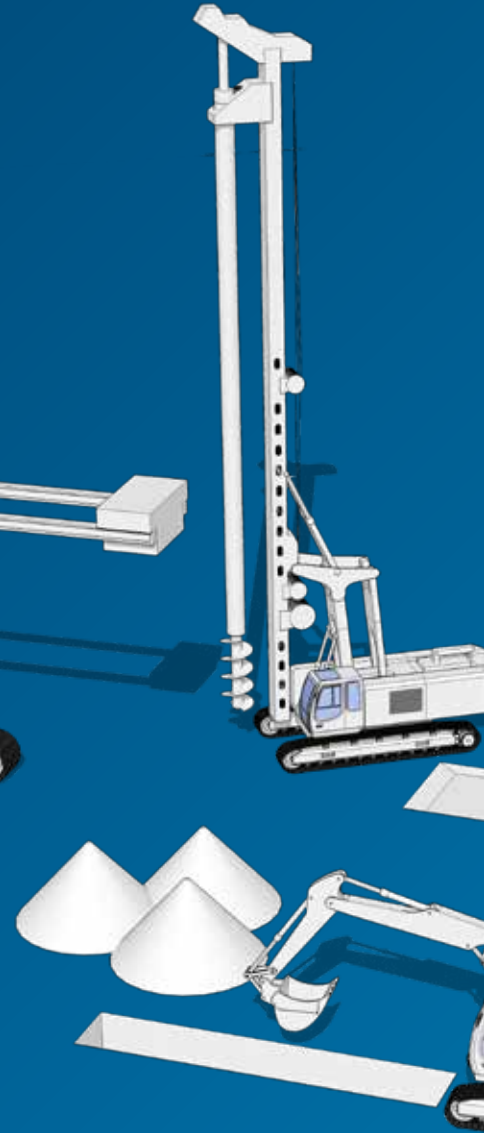



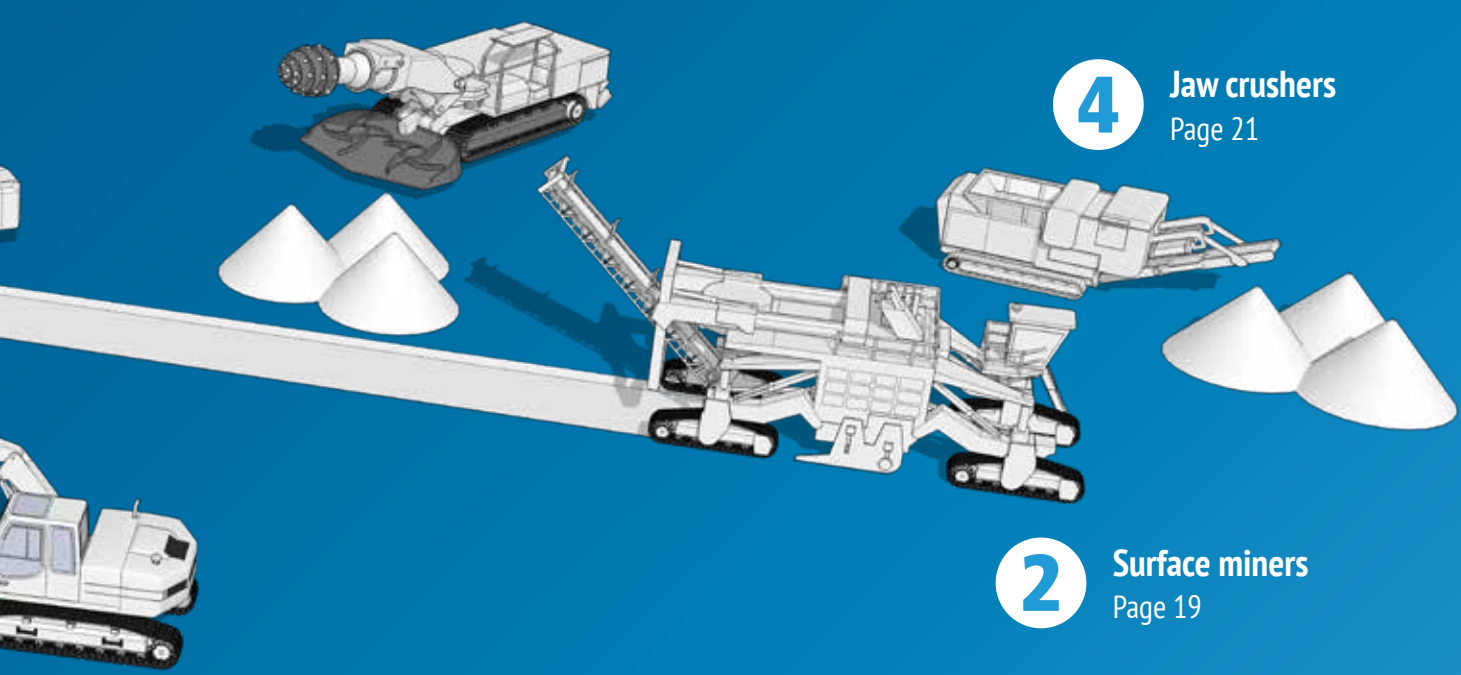

**4** Jaw crushers  
Page 21

**2** Surface miners  
Page 19

# Earth-Moving Machines



## Large excavators

From 150 to 1,400 tons

1

### Track drives

Bonfiglioli solutions for large tracked excavators are compact yet deliver high performance. The wide variety of ratio combinations allows our solutions to offer the best possible efficiency.

### Slew drives

Compactness and high performance are the two main features of Bonfiglioli solutions for large excavators' applications.

### Track drives

## 700C Series

#### Output torque

- 1 ... 625 kNm

#### Gear ratios

- 5.3 ... 492

#### Benefits

- Power shift capability
- Compact solution
- High performance

#### Features

- Two gear shifting transmission
- Hydraulic controlled shifting
- Integrated parking & emergency brake
- Optional cooling flow to input stage and clutch unit
- Wide variety of ratio combinations

## F Series

#### Output torque

- 620 ... 2,916 kNm

#### Gear ratios

- 249 ... 989

#### Benefits

- Power shift capability
- Compact solution
- High performance

#### Features

- Two gear shifting transmission
- Hydraulic controlled shifting
- Integrated parking & emergency brake
- Optional cooling flow to input stage and clutch unit
- Wide variety of ratio combinations

### Slew drives

## 700T Series

#### Output torque

- 1 ... 80 kNm

#### Gear ratios

- 3.4 ... 2,000

#### Benefits

- Compact structure
- Suitable for various hydraulic motors
- High performance

#### Features

- Notchless ground tooth root
- Integrated disc-brake
- High availability by highest teeth and production quality

## S Series

#### Output torque

- 5.5 ... 130 kNm

#### Gear ratios

- 23 ... 67

#### Benefits

- Compact structure
- Suitable for various hydraulic motors
- High performance

#### Features

- Notchless ground tooth root
- Integrated disc-brake
- High availability by highest teeth and production quality



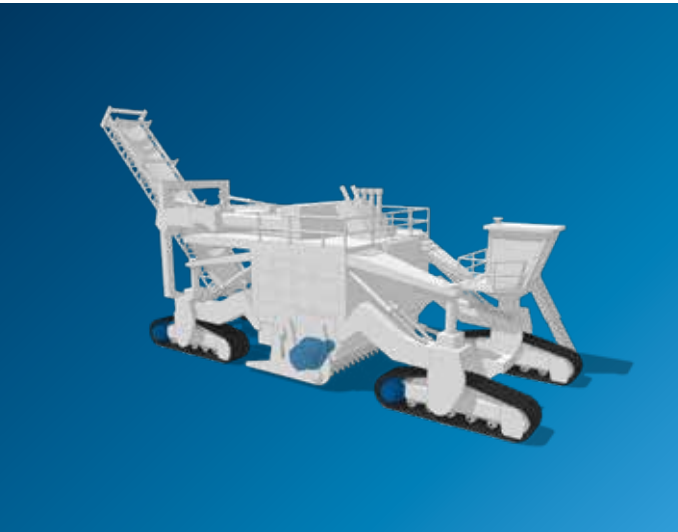

## Surface miners

### From 30 to 200 tons

2

#### Travel drives

Bonfiglioli solutions for tracked surface miners are compact yet deliver high performance. The wide variety of ratio combinations allows our solutions to offer the best possible efficiency.

#### Cutter drives

Compactness and high performance are the two main features of Bonfiglioli cutter drives for surface miners. Tailored to the hardness of the material to be mined, these solutions are customized to satisfy customer-specific requirements.

### Travel drives

## 700C Series

#### Output torque

- 1 ... 625 kNm

#### Gear ratios

- 5.3 ... 492

#### Benefits

- Power shift capability
- Compact solution
- High performance

#### Features

- Two gear shifting transmission
- Hydraulic controlled shifting
- Integrated parking & emergency brake
- Optional cooling flow to input stage and clutch unit
- Wide variety of ratio combinations

## F Series

#### Output torque

- 620 ... 2,916 kNm

#### Gear ratios

- 249 ... 989

#### Benefits

- Power shift capability
- Compact solution
- High performance

#### Features

- Two gear shifting transmission
- Hydraulic controlled shifting
- Integrated parking & emergency brake
- Optional cooling flow to input stage and clutch unit
- Wide variety of ratio combinations

### Cutter drives

## FA Series

#### Max cutting torque

- 8.5 ... 32 kNm

#### Input power

- 80 ... 300 kW

#### Gear ratios

- 16 ... 26

#### Benefits

- Compact structure
- High performance
- High availability by highest teeth and production quality

#### Features

- Notchless ground tooth root
- Different ratios
- Integrated disc-brake
- Suitable for various hydraulic motors



# Earth-Moving Machines



3

## Bucket wheel excavators

Up to 240,000 m<sup>3</sup>/d

### Track drives

Bonfiglioli solutions for bucket wheeled excavators are compact yet deliver high performance. The wide variety of ratio combinations allows our solutions to offer the best possible efficiency.

### Track drives

## 700C Series

#### Output torque

- 1 ... 625 kNm

#### Gear ratios

- 5.3 ... 492

#### Benefits

- Power shift capability
- Compact solution
- High performance

#### Features

- Two gear shifting transmission
- Hydraulic controlled shifting
- Integrated parking & emergency brake
- Optional cooling flow to input stage and clutch unit
- Wide variety of ratio combinations

## F Series

#### Output torque

- 620 ... 2,916 kNm

#### Gear ratios

- 249 ... 989

#### Benefits

- Power shift capability
- Compact solution
- High performance

#### Features

- Two gear shifting transmission
- Hydraulic controlled shifting
- Integrated parking & emergency brake
- Optional cooling flow to input stage and clutch unit
- Wide variety of ratio combinations

### Slew drive

## 300M Series

### Planetary gearbox and geared motor

#### Benefits

- Hydraulic or electric motor input solution
- Integration with negative brake
- High overload capacity
- Torque control
- Easy installation

#### Features

- Reinforced bearing output shaft
- Eccentric mounting flange option for pinion /girth gear adjustment
- Shock load up to 2,000,000 Nm
- Encoder and integrated load cell
- Base frame, coupling, brake, motor
- Oil expansion tank & oil level switch

### Bucket wheel drive

## 3/H Series

### Gearbox and geared motor

#### Benefits

- One-stop shop for a complete drive solution
- Extended oil service interval
- Maintenance free cooling device solution
- High overload capacity
- Highly transmissible torque and power

#### Features

- Modular design
- Shock load up to 2,000,000 Nm
- Increased bearing load capability
- Wide range of options
- Integrated forced oil lubrication
- Torque arm, base frame, coupling, brake, motor





4

## Jaw crushers

### From 30 to 80 tons

#### Track drives

Bonfiglioli solutions for tracked jaw crushers are compact yet deliver high performance. The wide variety of ratio combinations allows our solutions to offer the best possible efficiency.

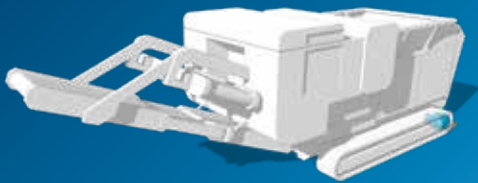

### Track drives

## 700C Series

#### Output torque

- 1 ... 625 kNm

#### Gear ratios

- 5.3 ... 492

#### Benefits

- Power shift capability
- Compact solution
- High performance

#### Features

- Two gear shifting transmission
- Hydraulic controlled shifting
- Integrated parking & emergency brake
- Optional cooling flow to input stage and clutch unit
- Wide variety of ratio combinations

## F Series

#### Output torque

- 620 ... 2,916 kNm

#### Gear ratios

- 249 ... 989

#### Benefits

- Power shift capability
- Compact solution
- High performance

#### Features

- Two gear shifting transmission
- Hydraulic controlled shifting
- Integrated parking & emergency brake
- Optional cooling flow to input stage and clutch unit
- Wide variety of ratio combinations

## FP Series

#### Output torque

- 100 ... 1,100 kNm

#### Gear ratios

- 248 ... 825

#### Benefits

- Compact design
- High torque & load capacity
- Available with failsafe parking brake and for most cartridge type fixed or variable.

#### Features

- Rotating housing
- Rugged design
- Mechanical lifetime seals
- 3-7 Planetary wheels per stage
- Notchless ground tooth root
- Different ratios
- Integrated disc-brake



# Global Presence



Bonfiglioli is a market force with a presence spanning 22 countries on 5 continents. Our organization makes the most of geographic proximity to offer complete solutions combining efficiency and competence.



3700  
EMPLOYEES



22  
BRANCHES



14  
PLANTS



550  
DISTRIBUTORS



80  
COUNTRIES

## We Are a Global Company

Thanks to an international network of sales branches and closely interconnecting production plants, we can guarantee the same high standards of Bonfiglioli quality anywhere at any given time. Aware that our direct presence in local markets is the key to long-lasting success, our family includes 22 sales branches, 14 production plants and more than 500 distributors around the world.

**Our organization is always close by, offering complete and efficient solutions and supporting our customers with dedicated services, such as co-engineering or after-sales assistance.**



# Bonfiglioli Worldwide Locations

## Australia

www.bonfiglioli.com.au  
2, Cox Place Glendenning NSW 2761  
Locked Bag 1000 Plumpton NSW 2761  
Tel. +61 2 8811 8000

## Brazil

www.bonfigliolidobrasil.com.br  
Travessa Cláudio Armando 171 - Bloco 3 - CEP 09861-730  
Bairro Assunção - São Bernardo do Campo - São Paulo  
Tel. +55 11 4344 2322

## China

www.bonfiglioli.cn  
Bonfiglioli Drives (Shanghai) Co., Ltd.  
#68, Hui-Lian Road, QingPu District,  
201707 Shanghai  
Tel. +86 21 6700 2000

## France

www.bonfiglioli.fr  
14 Rue Eugène Pottier  
Zone Industrielle de Moimont II - 95670 Marly la Ville  
Tel. +33 1 34474510

## Germany

www.bonfiglioli.de  
**Bonfiglioli Deutschland GmbH**  
Sperberweg 12 - 41468 Neuss  
Tel. +49 0 2131 2988 0

## Bonfiglioli Vectron

Europark Fichtenhain B6 - 47807 Krefeld  
Tel. +49 0 2151 8396 0

## O&K Antriebstechnik

Ruhrallee 8-12 - 45525 Hattingen  
Tel. +49 0 2324 2050 1

## India

www.bonfiglioli.in  
Bonfiglioli Transmissions Pvt. Ltd.  
Plot No. AC7-AC11, SIDCO Industrial Estate,  
Thirumudivakkam - 600 044 Chennai  
Tel. +91 44 2478 1035

## Industrial

Survey No. 528, Porambakkam High Road,  
Mannur Village, Sriperambudur Taluk - 602 105 Chennai  
Tel. +91 44 6710 3800  
Plot No. A-95, Phase IV, MIDC Chakan, Village Nighoje  
Pune, Maharashtra - 410 501

## Italy

www.bonfiglioli.it

## Headquarters

Bonfiglioli Riduttori S.p.A.  
Via Giovanni XXIII, 7/A - 40012 Lippo di Calderara di Reno  
Tel. +39 051 647 3111

## Mobile, Wind

Via Enrico Mattei, 12 Z.I. Villa Selva - 47100 Forlì  
Tel. +39 0543 789111

## Industrial

Via Bazzane, 33/A - 40012 Calderara di Reno  
Tel. +39 051 6473111  
Via Trinità, 1 - 41058 Vignola  
Tel. +39 059 768511  
Via Sandro Pertini lotto 7b - 20080 Carpiano  
Tel. +39 02 985081

## Bonfiglioli Mechatronic Research

Via F. Zeni 8 - 38068 Rovereto  
Tel. +39 0464 443435/36

## New Zealand

www.bonfiglioli.co.nz  
88 Hastie Avenue, Mangere Bridge, 2022 Auckland  
PO Box 11795, Ellerslie  
Tel. +64 09 634 6441

## Singapore

www.bonfiglioli.com  
24 Pioneer Crescent #02-08  
West Park Bizcentral - Singapore, 628557  
Tel. +65 6268 9869

## Slovakia

www.bonfiglioli.com  
Robotnícka 2129  
Považská Bystrica, 01701 Slovakia  
Tel. +421 42 430 75 64

## South Africa

www.bonfiglioli.co.za  
55 Galaxy Avenue, Linbro Business Park - Sandton  
Tel. +27 11 608 2030

## Spain

www.tecnotrans.bonfiglioli.com  
Tecnotrans Bonfiglioli S.A.  
Pol. Ind. Zona Franca, Sector C, Calle F, nº 6  
08040 Barcelona  
Tel. +34 93 447 84 00

## Turkey

www.bonfiglioli.com.tr  
Atatürk Organize Sanayi Bölgesi, 10007 Sk. No. 30  
Atatürk Organize Sanayi Bölgesi, 35620 Çiğli - Izmir  
Tel. +90 0 232 328 22 77

## United Kingdom

www.bonfiglioli.co.uk  
**Industrial**  
Unit 7, Colemeadow Road  
North Moons Moat - Redditch, Worcestershire B98 9PB  
Tel. +44 1527 65022

## Mobile, Wind

3 - 7 Grosvenor Grange, Woolston  
Warrington - Cheshire WA1 4SF  
Tel. +44 1925 852667

## USA

www.bonfiglioliusa.com  
3541 Hargrave Drive  
Hebron, Kentucky 41048  
Tel. +1 859 334 3333

## Vietnam

www.bonfiglioli.vn  
Lot C-9D-CN My Phuoc Industrial Park 3  
Ben Cat - Binh Duong Province  
Tel. +84 650 3577411



We have a relentless commitment to excellence, innovation and sustainability. Our team creates, distributes and services world-class power transmission and drive solutions to keep the world in motion.

#### **HEADQUARTERS**

Bonfiglioli Riduttori S.p.A.  
Via Giovanni XXIII, 7/A  
40012 Lippo di Calderara di Reno  
Bologna (Italy)  
[www.bonfiglioli.com](http://www.bonfiglioli.com)

